























Assembly Instructions

Case & Maintenance

 	Not for commercial use. For residential use only.
 	Furniture may scratch floors. We recommend using furniture pads to protect your floors.
 	Do not put hot items directly on furniture surface.
 	Do not clean furniture with harsh cleansers or polish.
 	Do not place furniture under direct sunlight.
 	Do not write on furniture near heating or cooling vents.
 	Do not write on furniture without a padded barrier to protect the surface.
 	Do not place furniture outside for indoor use only
 	Stains may be removed with mild soap solution and damp cloth.
 	Children should not climb or jump on the furniture.
 	Dust and pick-ups spills using a clean, non-colored, lint-free cloth.



Please look in the box for hardware packs and legs.

Sets offshipp in multiple boxes and may arrive a day or two apart.

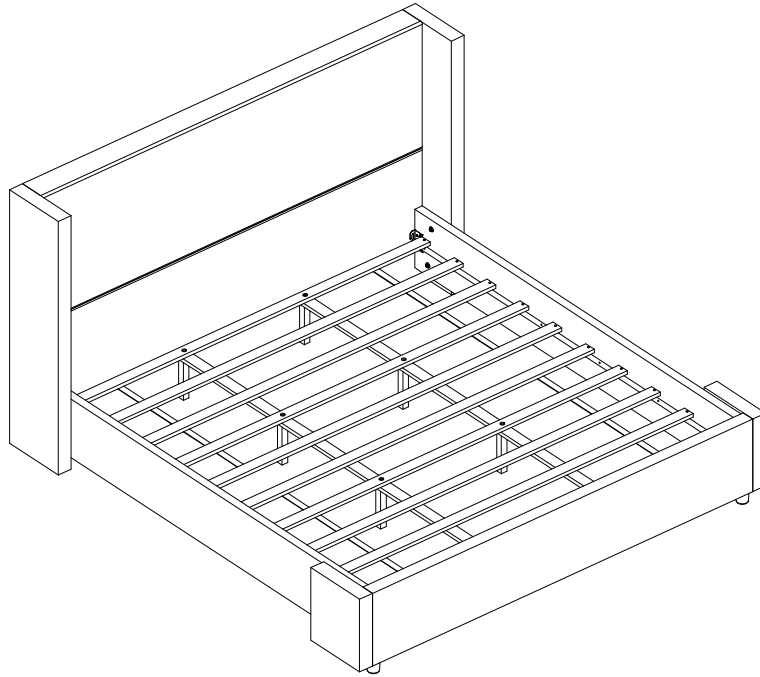
King Bed N769P370472W



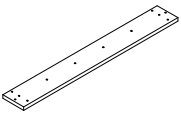
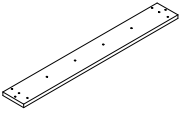
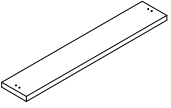



Part List

③		Side Rail(R)	1
④		Side Rail(L)	1
⑤		Footboard	1
⑦		Middle Support bar	2
⑧		Support Rail	2

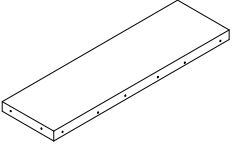
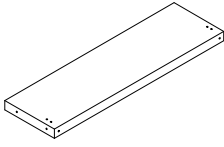
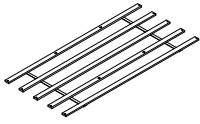
N769P370471W

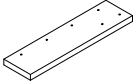
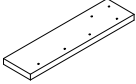
Part List



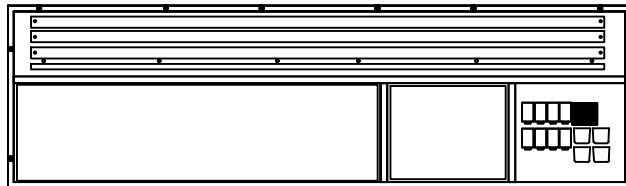





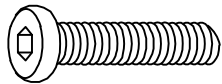
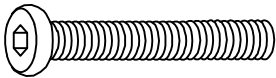

Label	Picture	Description	QTY
①		Upper tier Headboard	1
②		Lower tier Headboard	1
⑥		Slats	2
⑨		Bed leg	4
⑩		Center Support Leg	8
⑪		Headboard Wing (R)	1
⑫		Headboard Wing (L)	1
⑬		Footboard Wings	2

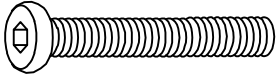

Noted : Slats (6), Bed leg(9),Center Support Leg (10), Headboard Wing (11)(12), Footboard Wing (13) and Hardware package are packed behind the Upper tier Headboard (1) and Lower tier Headboard(2).Open the fabric cover.

N769P370471W









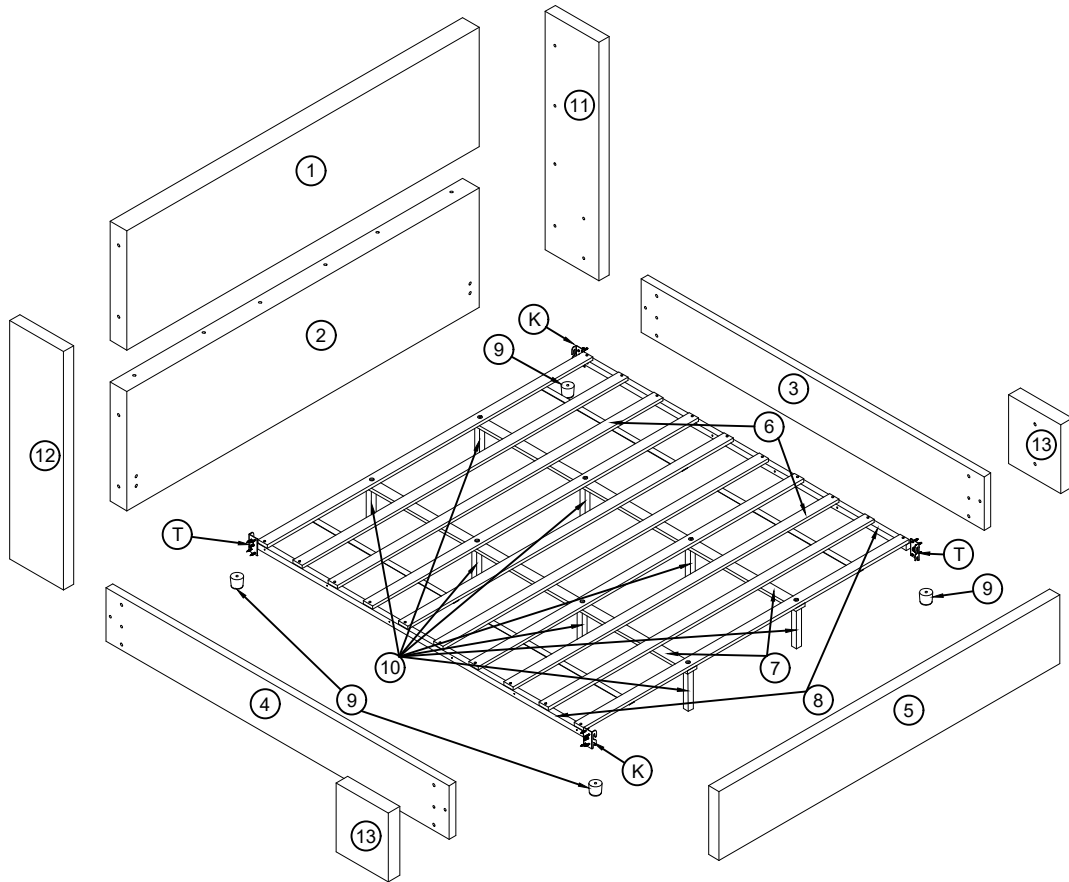

Hardware





Label	Picture	Description	QTY
A		Screw(4x30mm)	36+1
B		Bolts(5/16x30mm)	12+1
C		Bolts(5/16x50mm)	30+1
D		Bolts(1/4x50mm)	8+1
E		Lock washer(5/16")	50+1
F		Flat washer(5/16")	50+1
G		Lock washer(1/4")	8+1
H		Flat washer(1/4")	8+1
J		Bolts(5/16x70mm)	8+1
T		Metal pad	2
K		Metal pad	2
M		Allen Wrench(M4)	1+1

Assembly Preparation

Before Beginning assembly:



A  x 36pcs+1	C  x 30 pcs+1	E  x 50pcs+1	G  x 8pcs+1
B  x 12pcs+1	D  x 8pcs+1	F  x 50pcs+1	H  x 8pcs+1
	J  x 8 pcs+1		M  x 1pcs+1

-  Read the instructions cover to cover
-  Have 2 adults on hand for assembly
-  Do not assemble on flooring or carpet
-  Assemble on a clean, non-marring surface (packing foam)
-  Save all packaging until finished

Assembly Steps

OVERVIEW

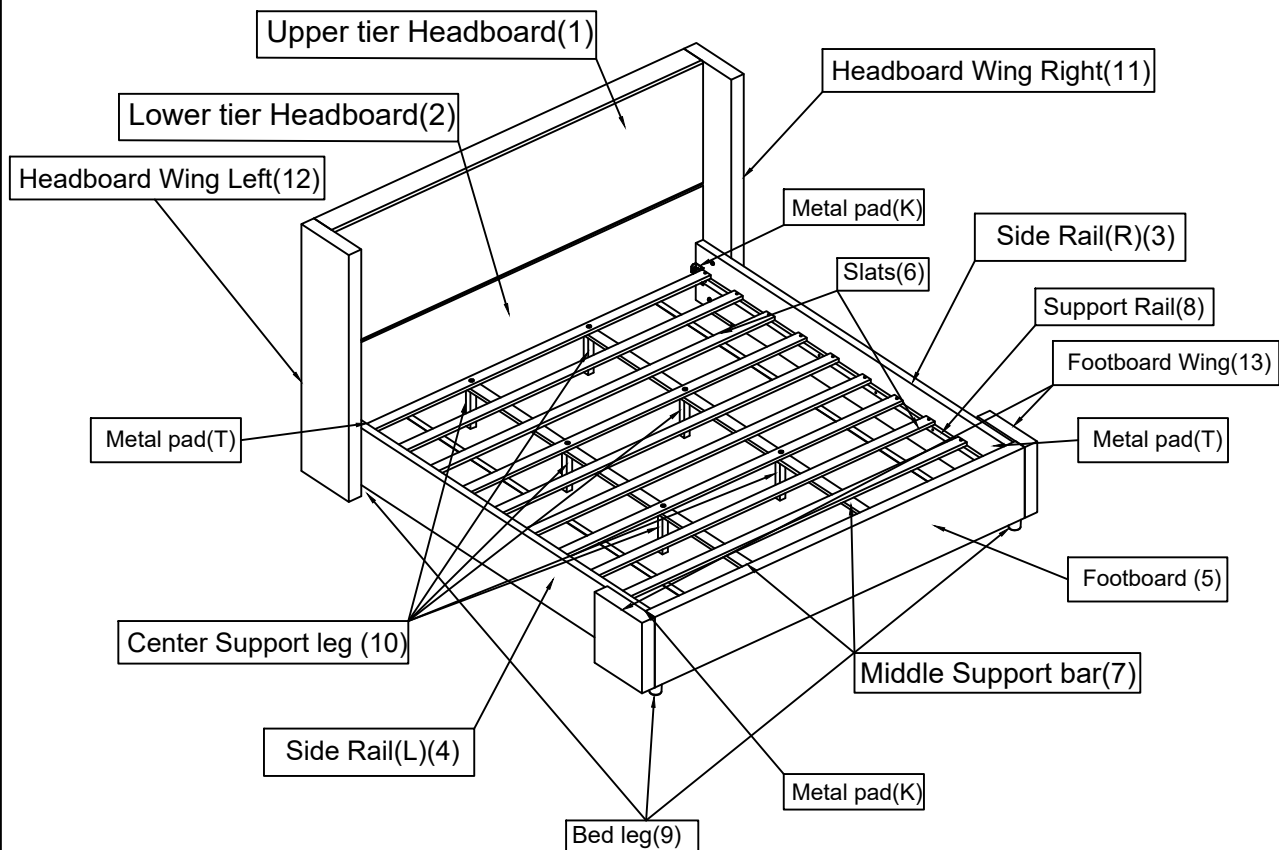

FRONT FACING

This Bed have multiple parts and may require up to 30 minutes to assemble. To give you an overview of the Bed parts, the above picture is to help you put the various parts into perspective. Please read through the instructions below to familiarise yourself with the parts and steps before assembly.

Note: It is recommended that you have an adult partner to assist during the entire assembly process.

Step 1

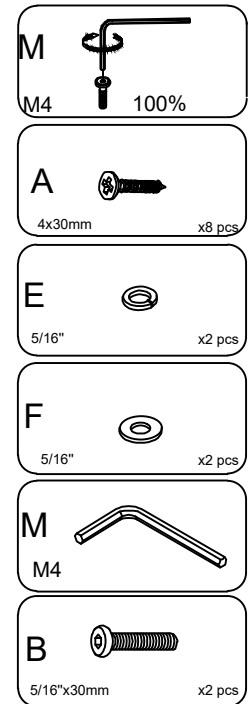
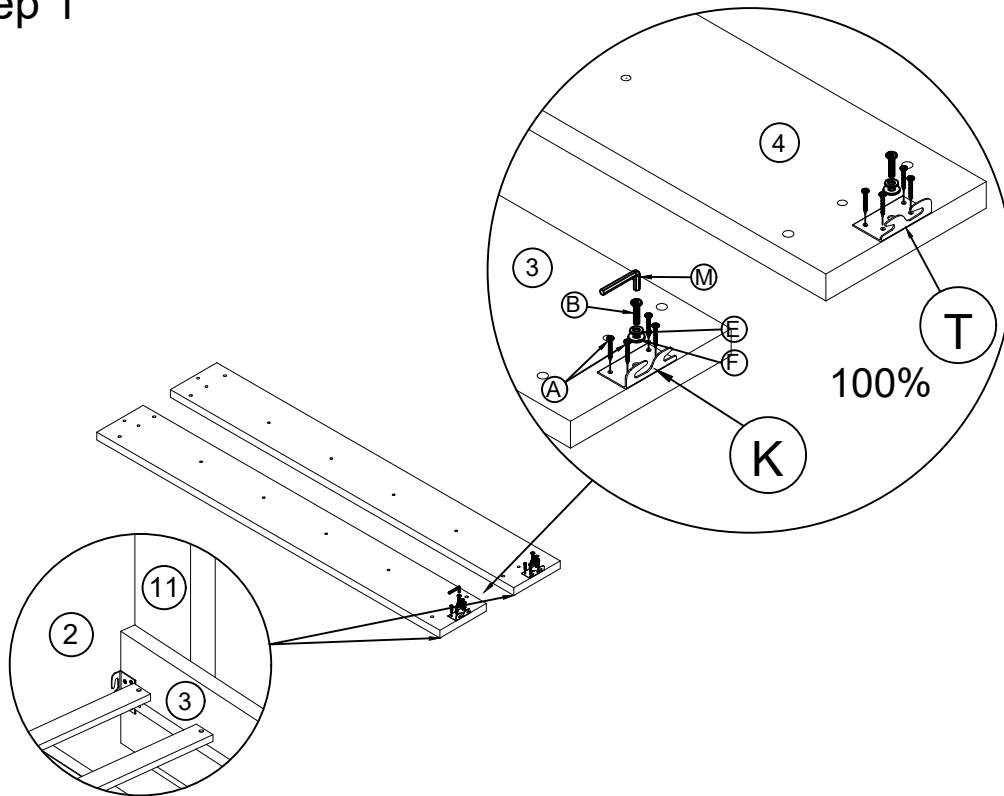

Attach the Metal pad (K) to the Side Rail (R) (3), attach the Metal pad (T) to the Side Rail (L) (4), by using the Bolts (B), Flat Washer (F), Lock Washer (E) and Screw (A) with Allen Key (M).

Note: The Metal pad look is facing down and this place is connected to the Lower tier Headboard (2).

Step 2

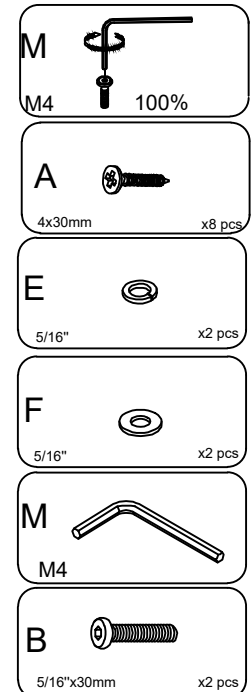
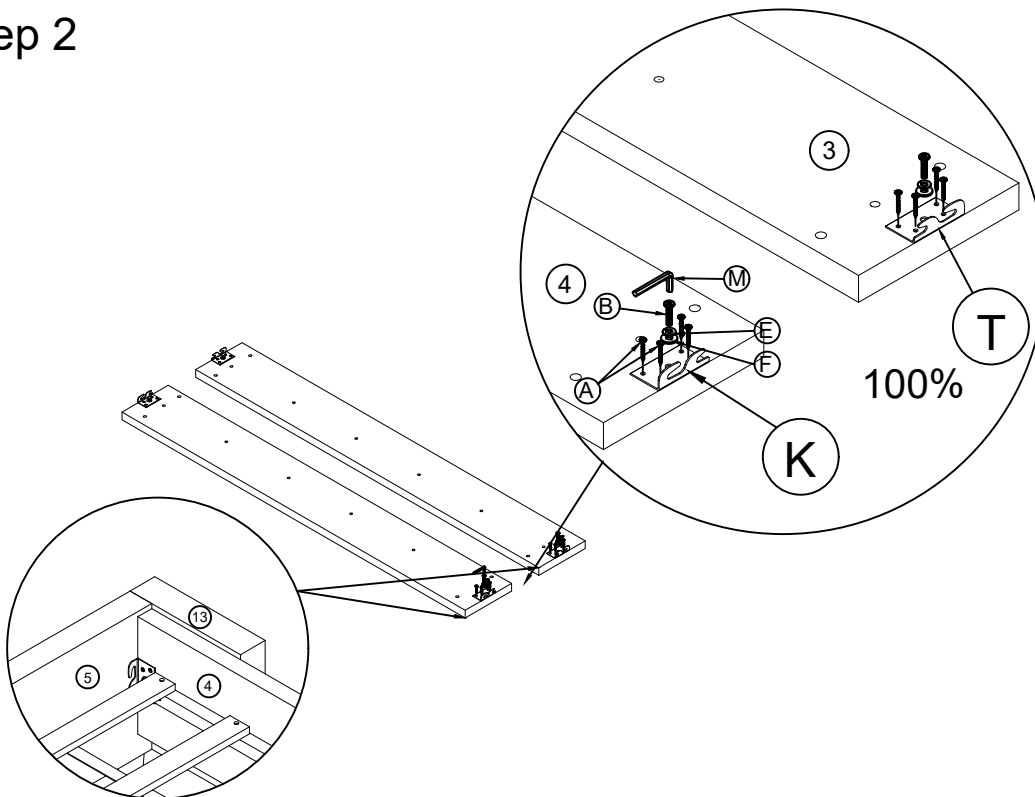

Attach Metal pad (T) to the Side Rail (3), attach Metal pad (K) to the Side Rail (4), by using the Bolts (B), Flat Washer (F), Lock Washer (E) and Screw (A) with Allen Key (M).

Note :The direction of the Metal Pad and this place is connected to the Footboard (5).

Step 3

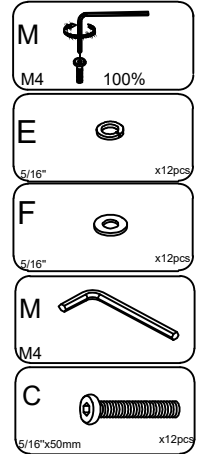
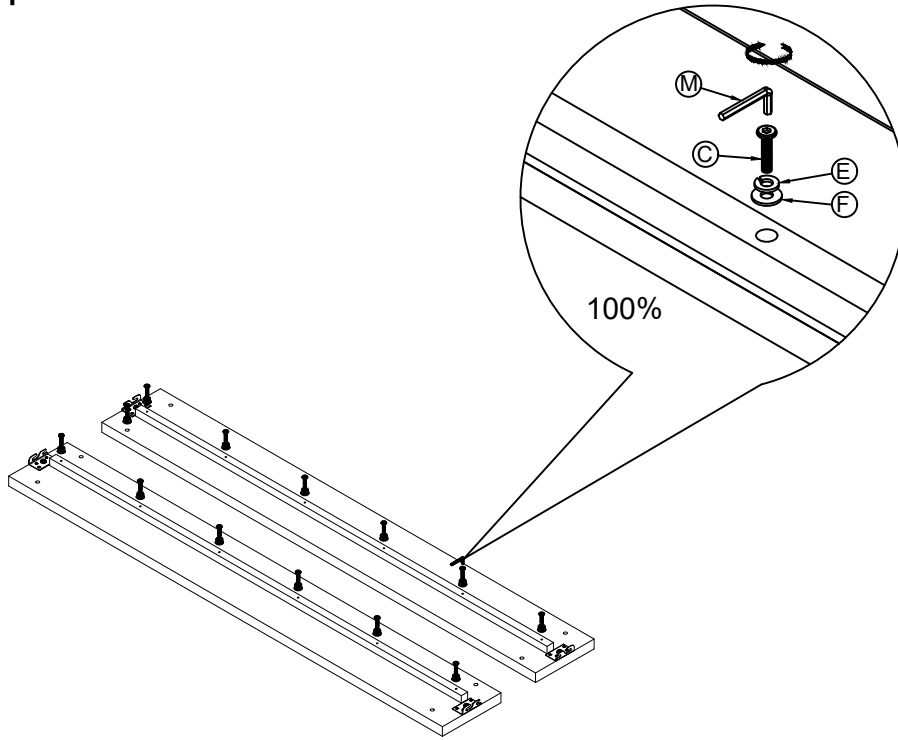

Attach the Support Rail (8) to the Side Rail (3) and the Side Rail (4). By using the Bolts (C), the Flat Washer (F) and the Lock Washer (E) with M4 Allen Key (M)

Step 4

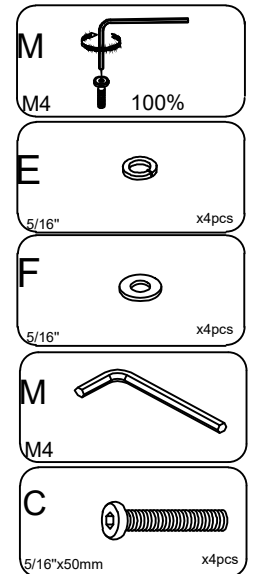
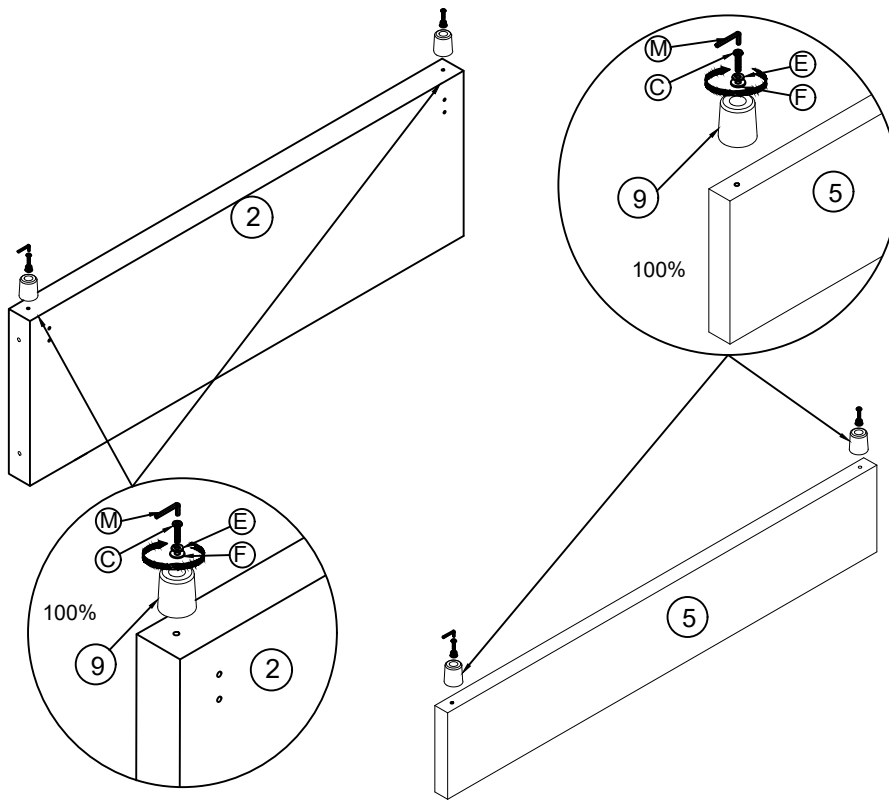

Use Bolts (C) and Lock Washer (E) with Flat Washer (F). Then attach 2 Bed Legs (9) to the Footboard (5) Storage (2) and 2 Bed Legs (9) to the Lower tier Headboard (2).

Step 5

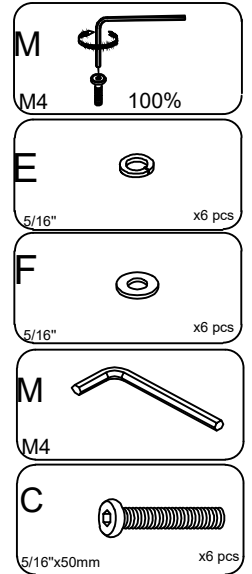
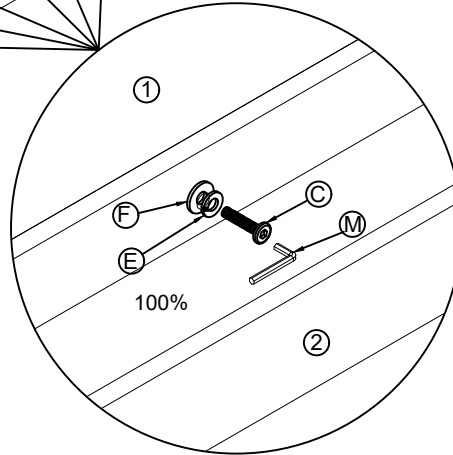
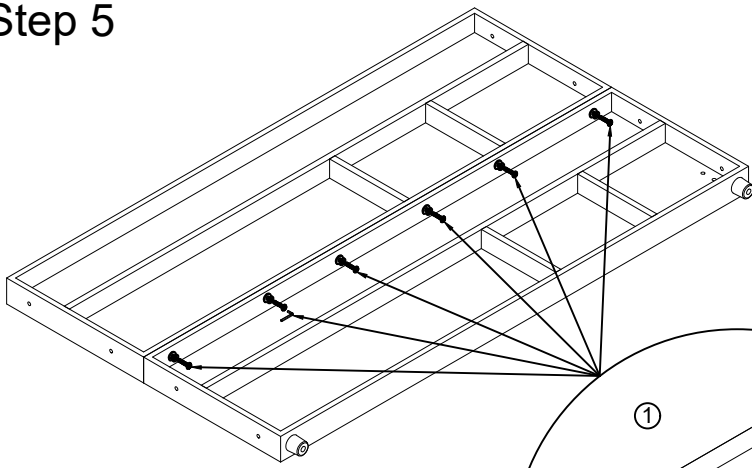

Attach the Upper tier Headboard(1) to the Lower tier Headboard Storage(2). By using the Bolts (C), the Flat Washer(F) and the Lock Washer(E) with M4 Allen Key(M)

Step 6

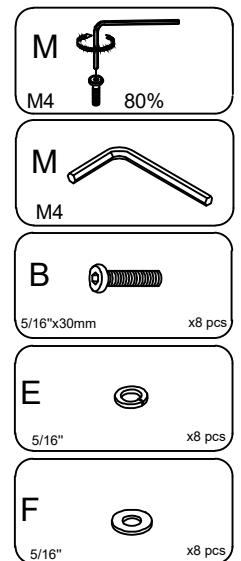
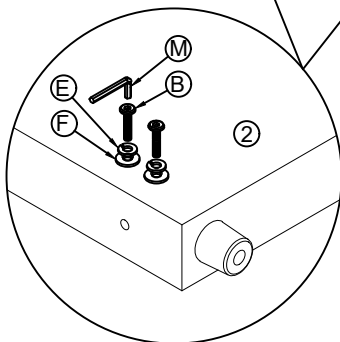
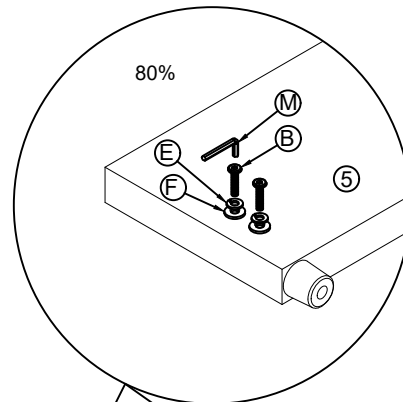
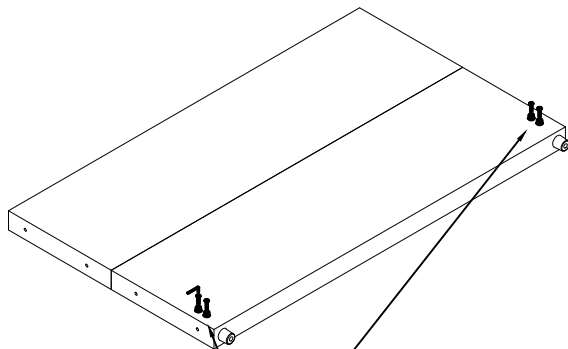

Use Bolts (B), Lock Washer (E) and Flat Washer (F) with Allen Key (M) to screw into the Headboard Storage(2) and Footboard (5) to connect Side Rails. Note: The Bolts (B) is only half assembled.

Step 7

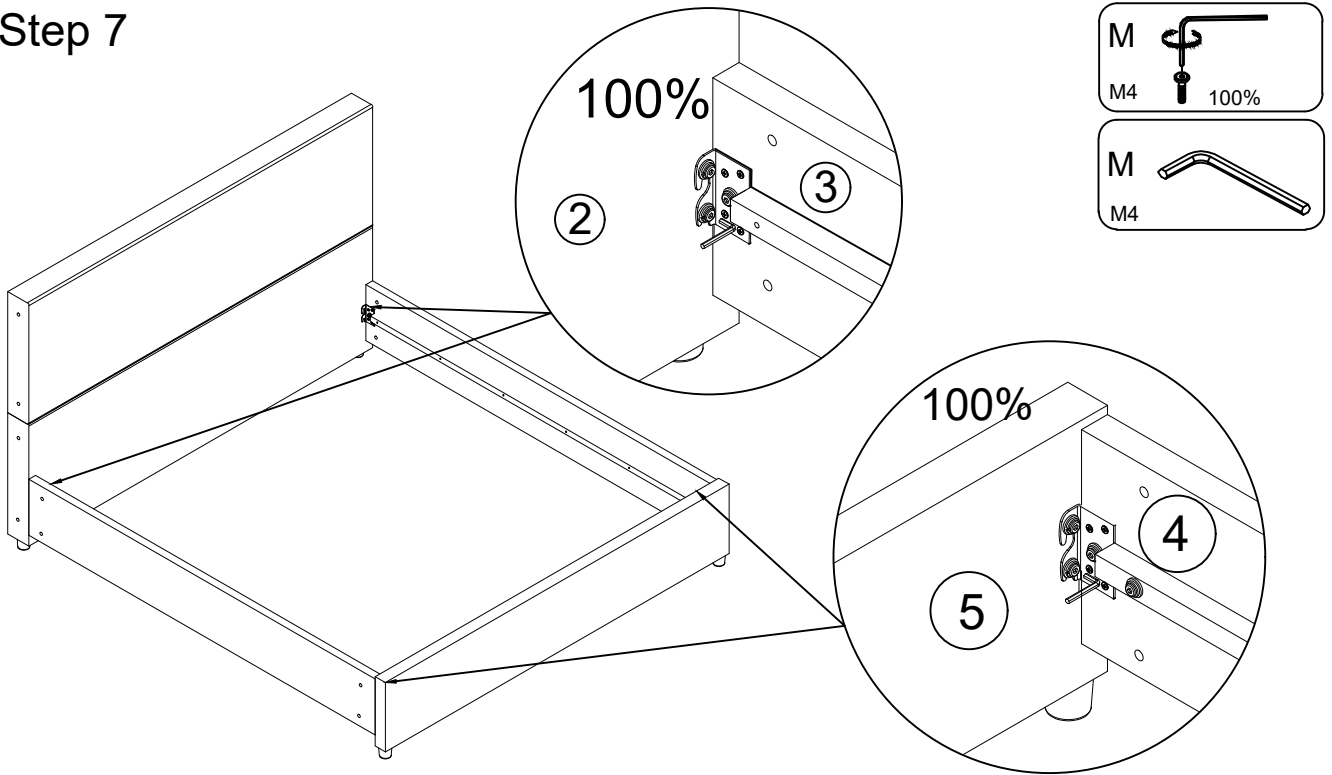

Attach the Side Rail (3) and the Side Rail (4) to the Lower tier Headboard(2), by using M4 Allen Wrench (M) to tighten the Bolts (B). Then attach the Footboard (5) to the Side Rail (3) and the Side Rail (4) by using M4 Allen Wrench (M) to tighten the Bolts (B). (Note: the direction of the Metal pad is down)

Step 8

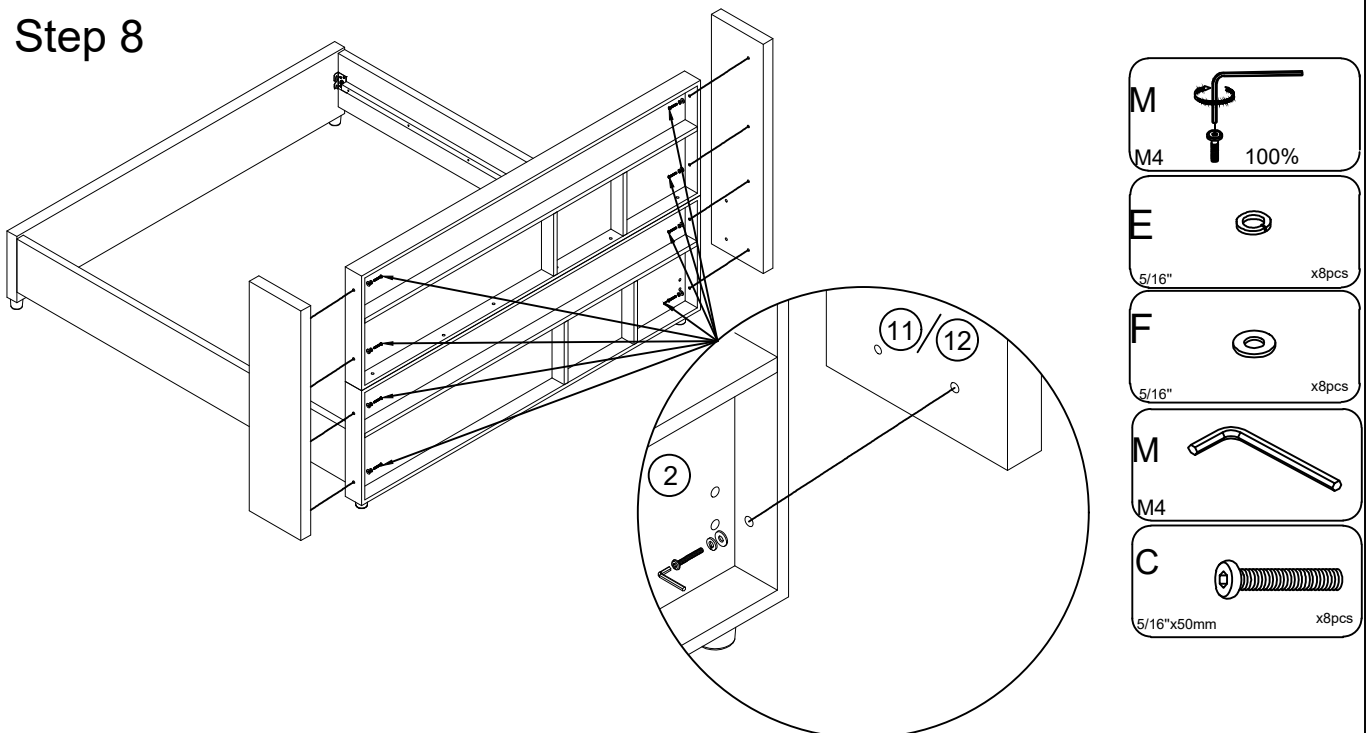

Use the Bolts (C), Lock washer (E) and Flat washer (F) to connect the Headboard Wing (R)(12) and Headboard Wing (L)(13) into Upper tier Headboard(1) and Lower tier Headboard(2) then tighten with Allen Wrench (M).

Step 9

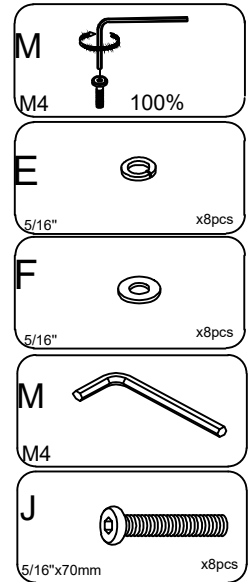
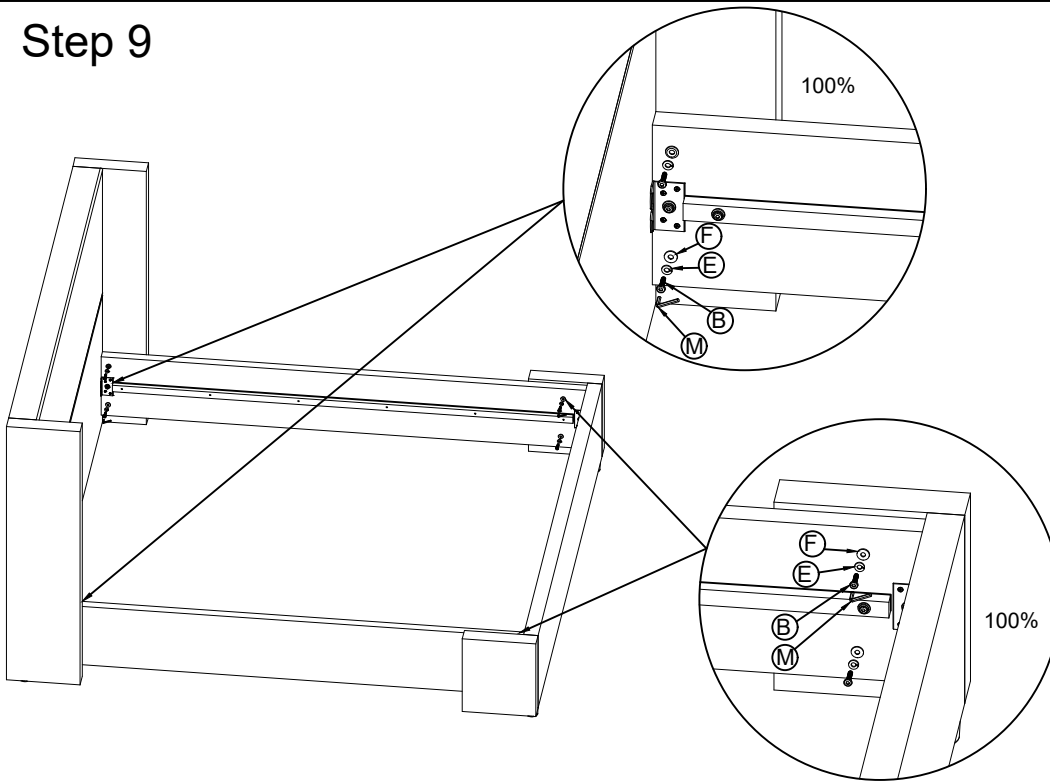

Attach the Headboard Wing (R)(11) to the Side Rail (3), attach the Headboard Wing (L)(12) to the Side Rail(4),by using the Bolts (J), Flat Washer (F), Lock Washer (E) and Screw (A) with Allen Key (M). Attach the Footboard Wing(13) to the Side Rail(3) and Side Rail(4),by using the Bolts (J), Flat Washer (F), Lock Washer (E) and Screw (A) with Allen Key (M)

Step 10

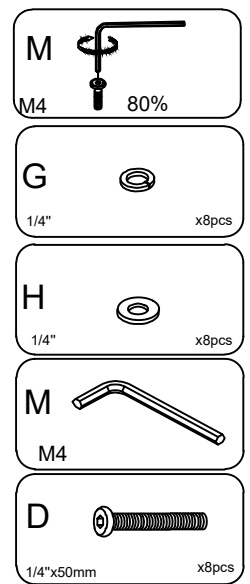
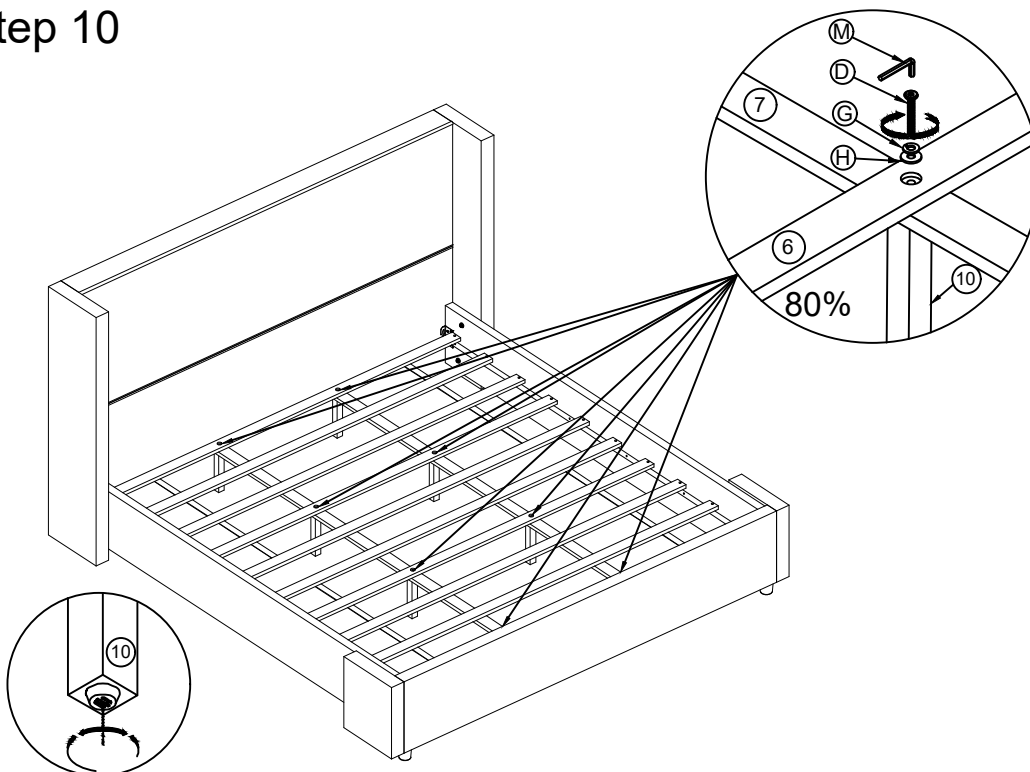

Align the assembly position on the Middle Support Bar (7) with the Center Support Leg (10) and the Slats with 4pre-holes (6). Then attach the Slats with 4pre-holes (6) and the Middle Support Bar (7) to the Center Support Leg (10).By using the Bolts (D),Lock Washer (G) with Flat Washer (H) with M4 Allen Wrench (M).

Step 11

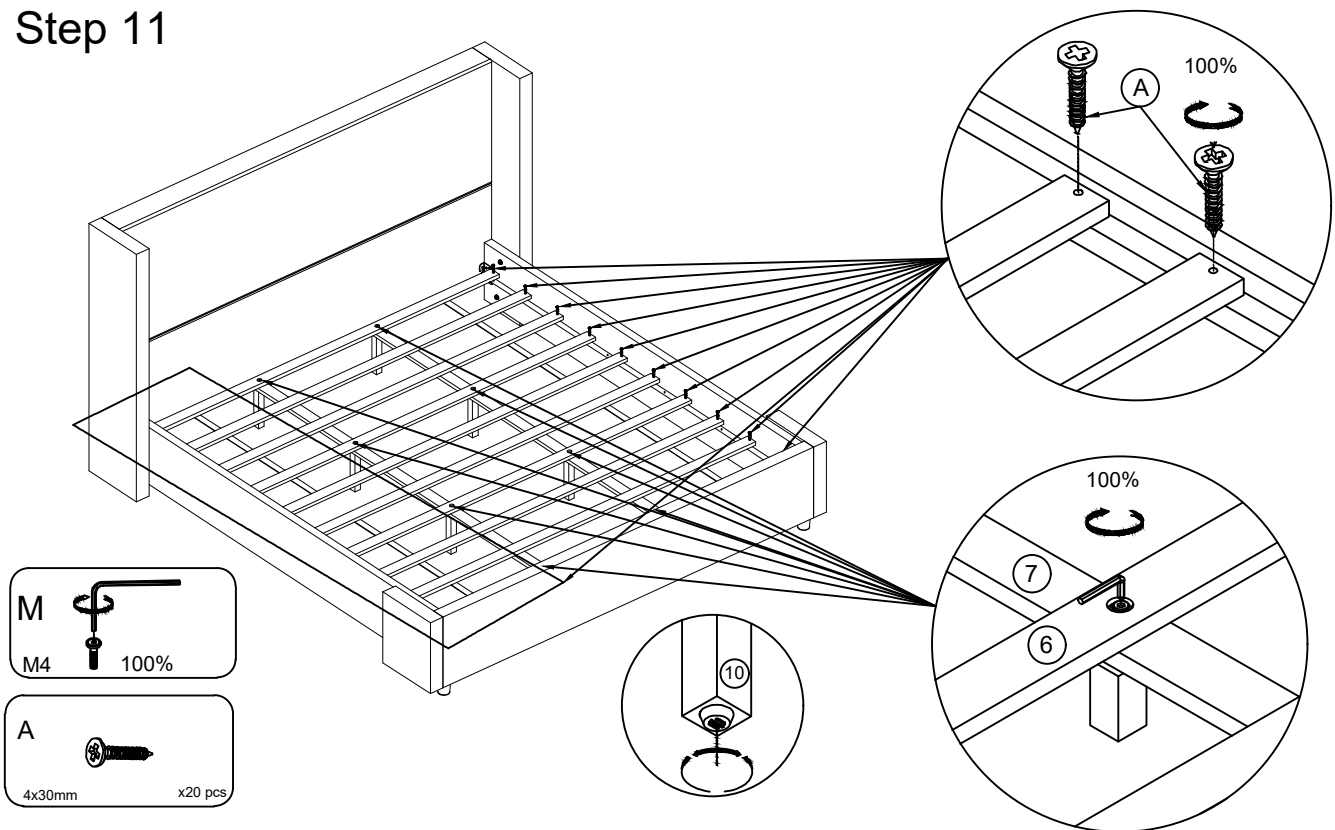

Attach the Slats with 4 pre-holes (6) and the Slat with 2 pre-holes (6) to the bed Sides Rail (3) and (4). Use screw A. Finally, use the M4 Allen Wrench (M) to tighten the Bolts (D) 100%. Adjustable leveling foot of Center Support Legs.

Finish

Place the Bed on a LEVEL SURFACE.

Inspect it and make sure all parts are adequately connected.

Don't push too hard, shake on the bed.

This would help to align all the parts at the joint areas.

CAUTION 1: When tightening these screws, tighten sequentially.

DO NOT tighten any screws fully and then towards the next one.

This would cause the frame to warp.

If there is still wobbles, loosen the screws and execute this same process. **DO NOT** tighten any screw fully and then towards the next one.

WARNING!! IF BED IS NOT STABLE, IT COULD LEAD TO DAMAGING THE PRODUCT.

Ensure all screws are fully locked into position.

The bed is ready to be used.

Caution 2: This bed is ready to be used.