

# Product Installation Instructions

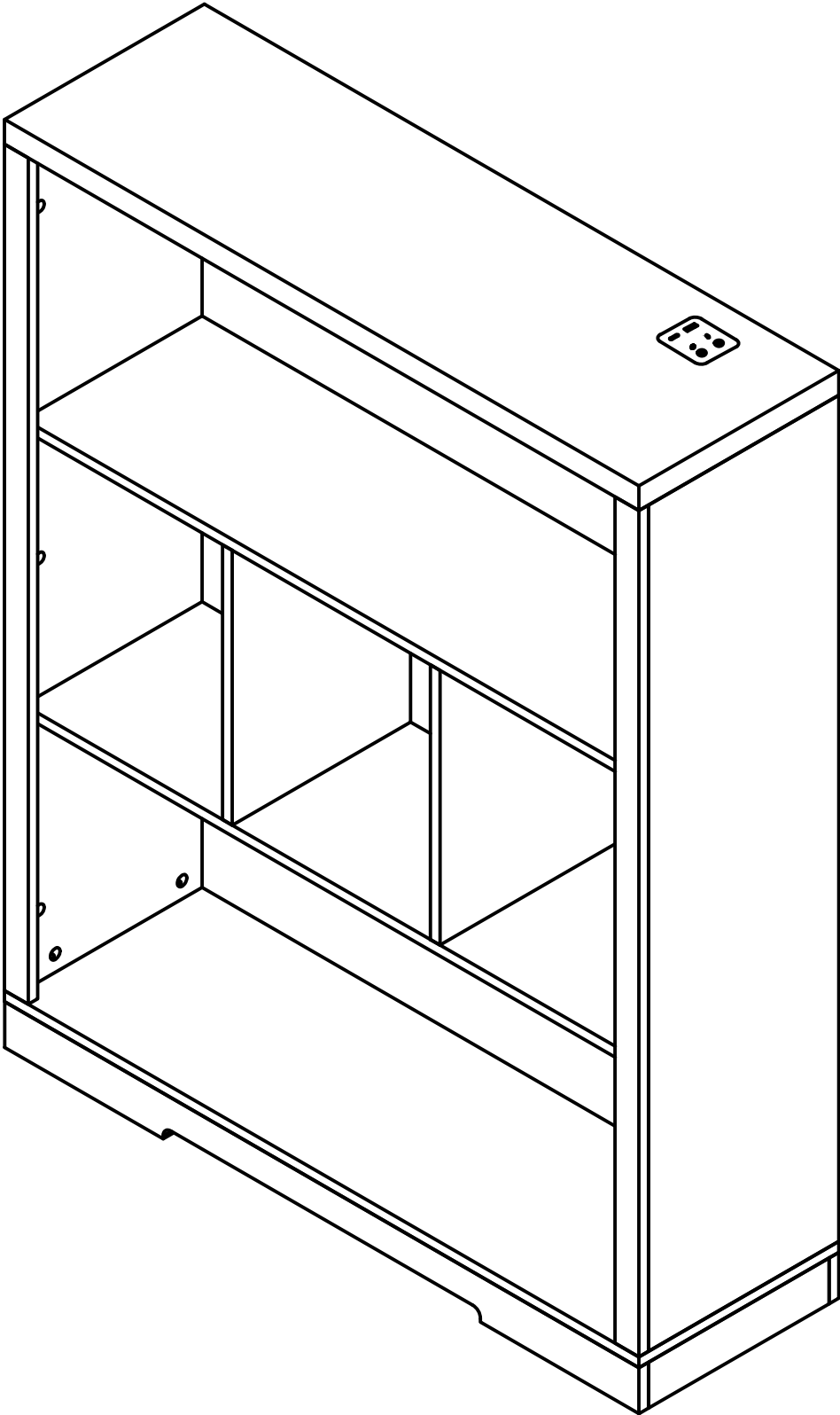

# Product structure decomposition

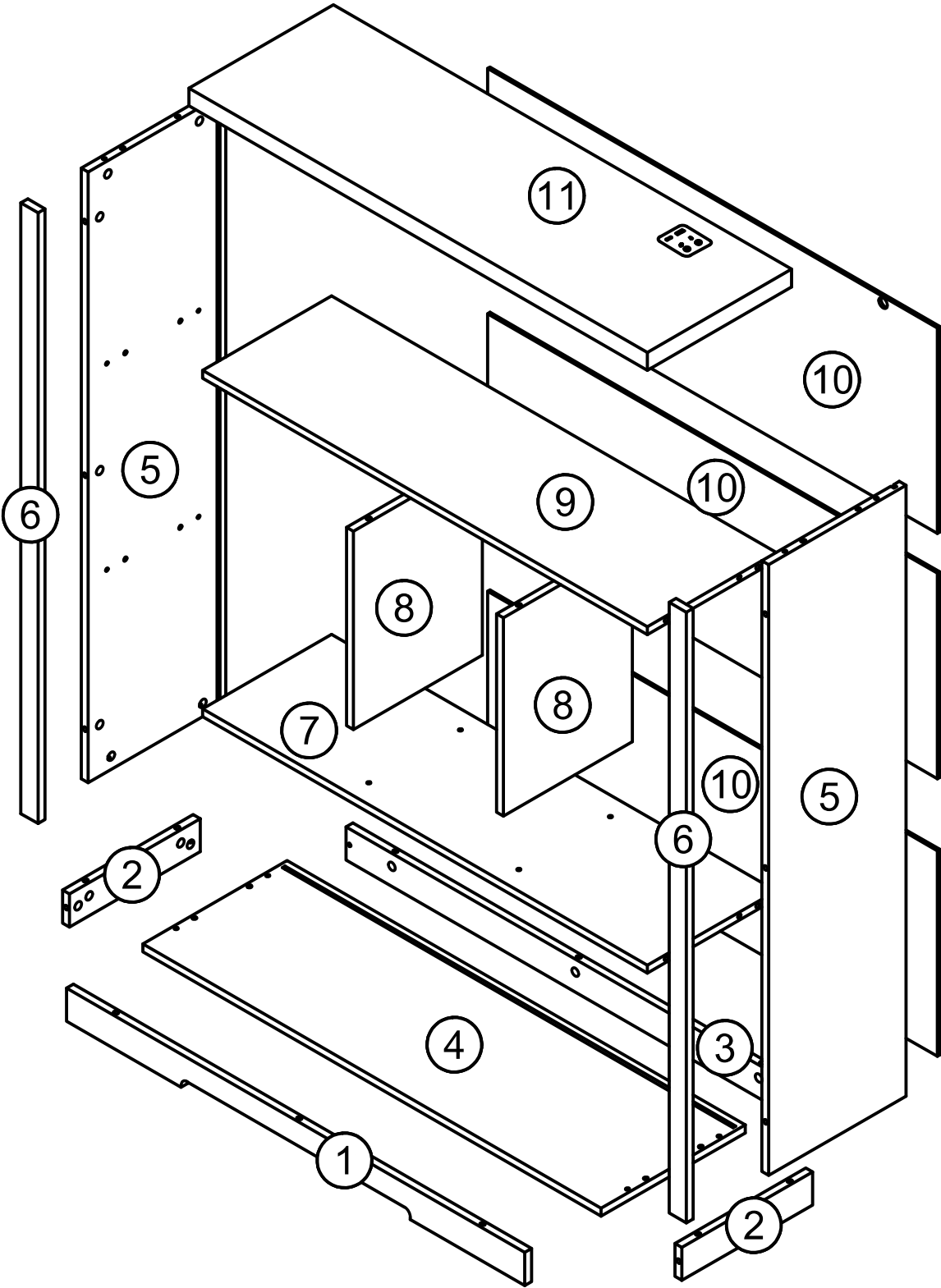

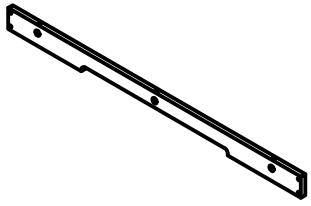

1x1

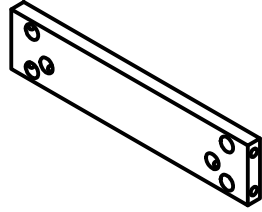

2x2

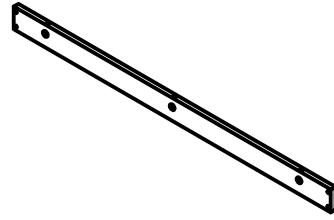

3x1

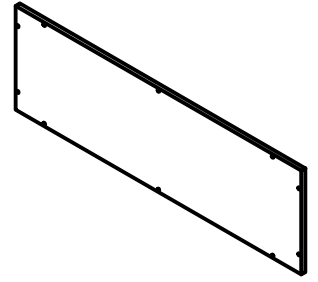

4x1

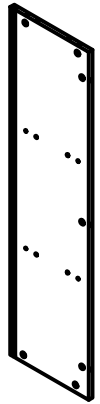

5x2



6x2

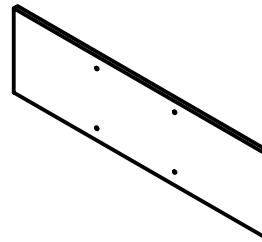

7x1

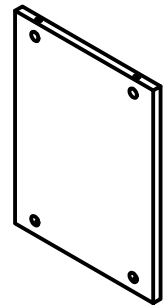

8x2

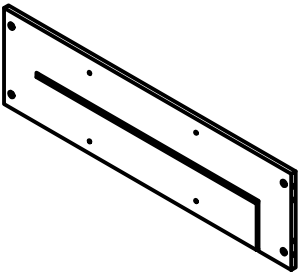

9x1

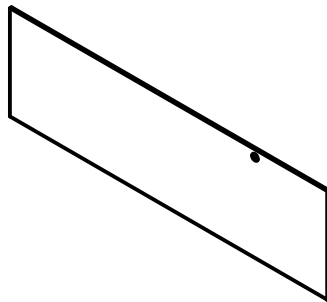



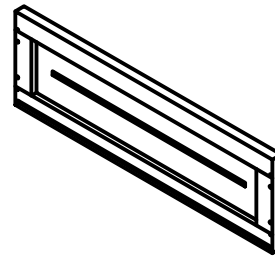

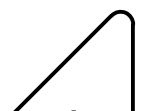

10x3

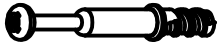

11x1

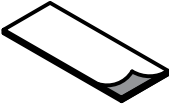
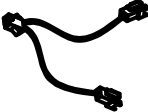

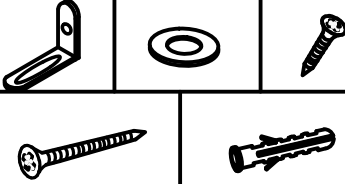



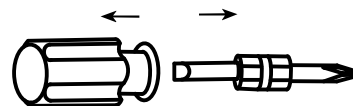
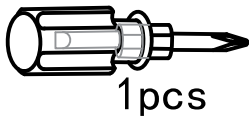

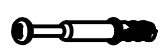

# Accessories list

A		Two In One Screw (6x28mm)	42pcs +4pcs
B		Two In One Nut (10x12mm)	42pcs +4pcs
C		Wood Chipping (6x30mm)	16pcs +2pcs
D		Non-slip pads	6pcs +2pcs
E		1 bis 2 power extension cable	1pcs
F		Fixing clip & screw (3x16mm)	10pcs +3pcs
G		Foot nail	4pcs +2pcs
H		Anti fall hardware	2pcs
		AC/DC Adapter (12V=3.0A)	1pcs

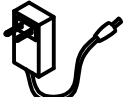

Double-head screwdriver, use as required

A		42 pcs	B		42 pcs	C		16 pcs
D		6 pcs	E		1 pcs	F		10 pcs
G		4 pcs	H		2 pcs			1 pcs

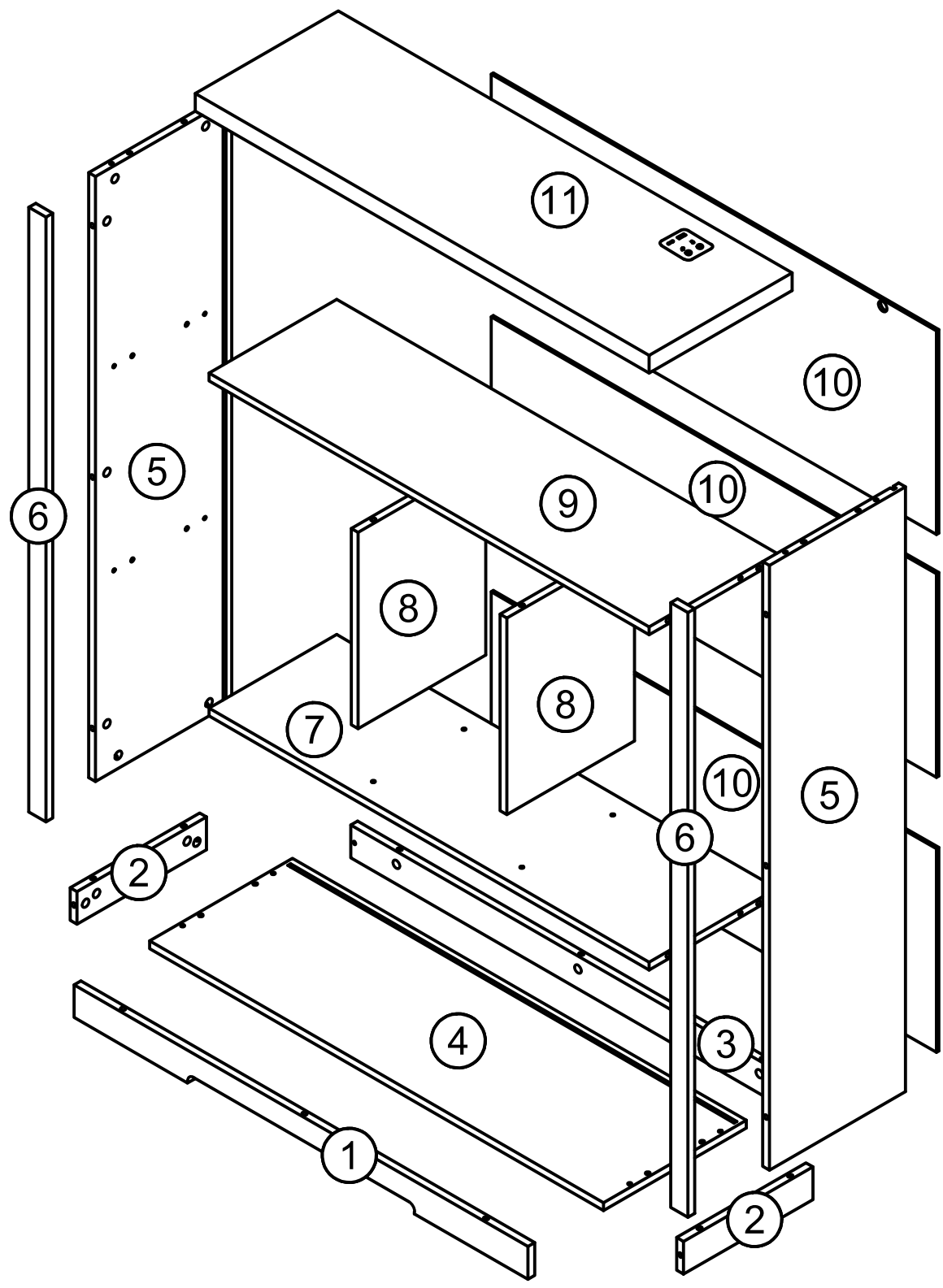

Step 1

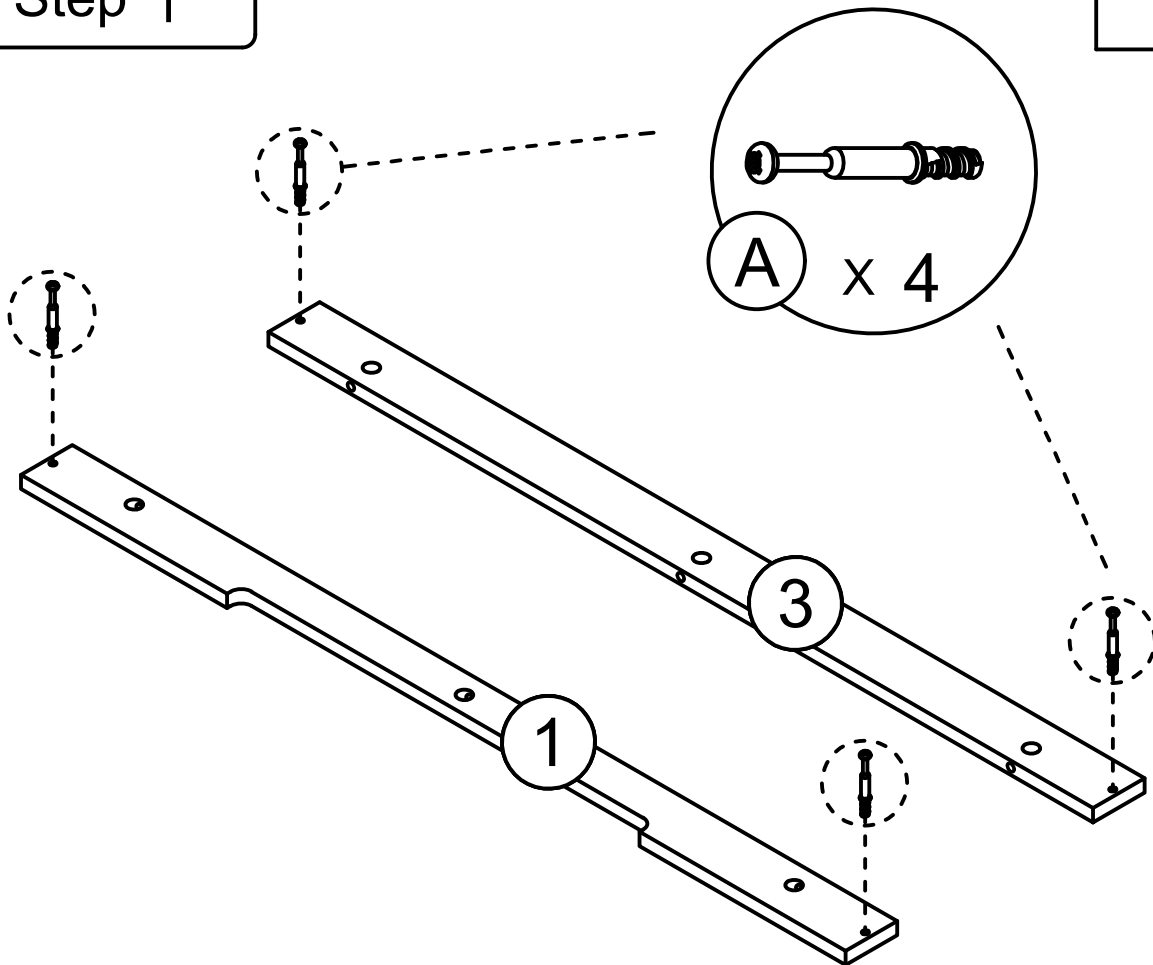
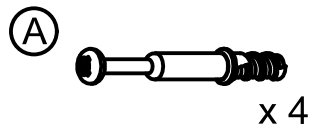

Step 2

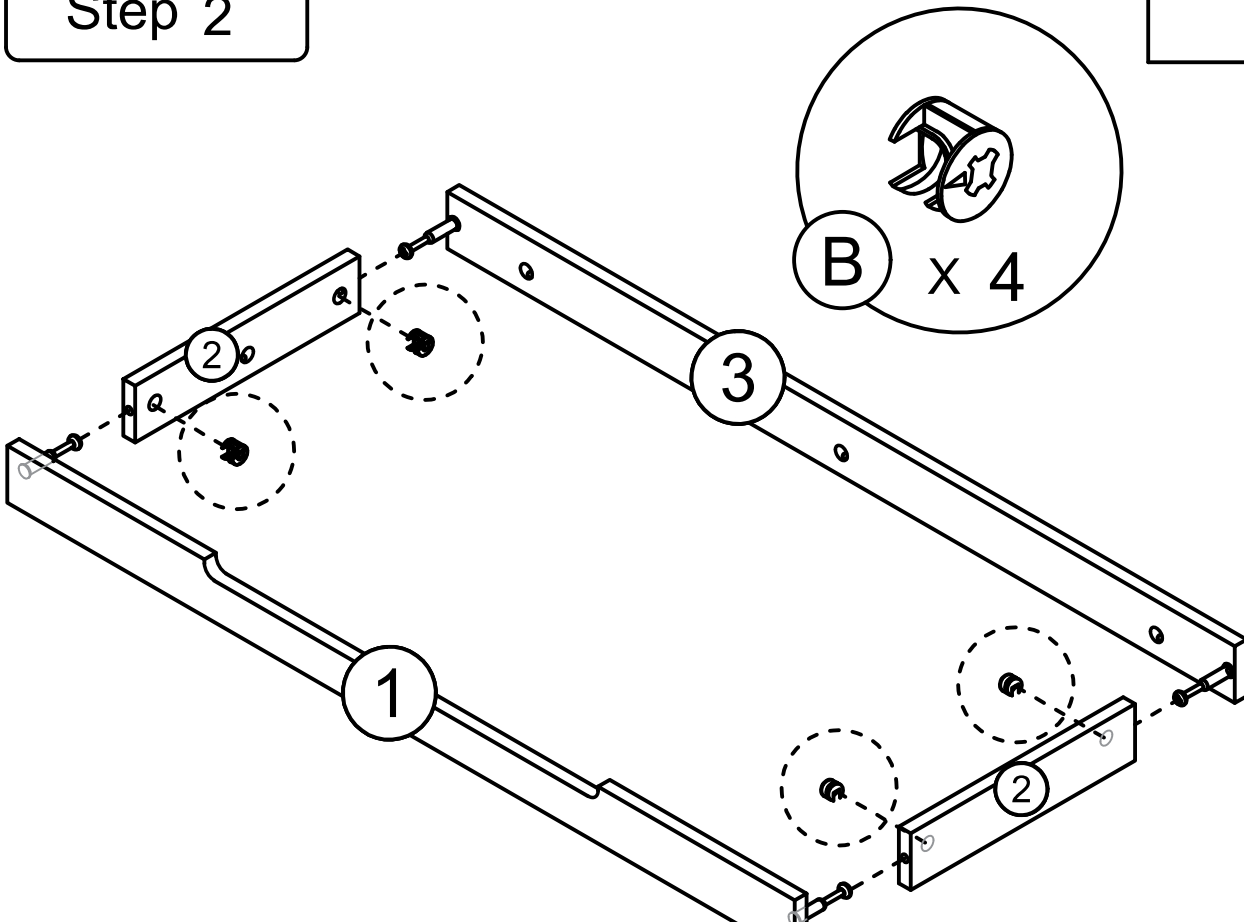

Step 3

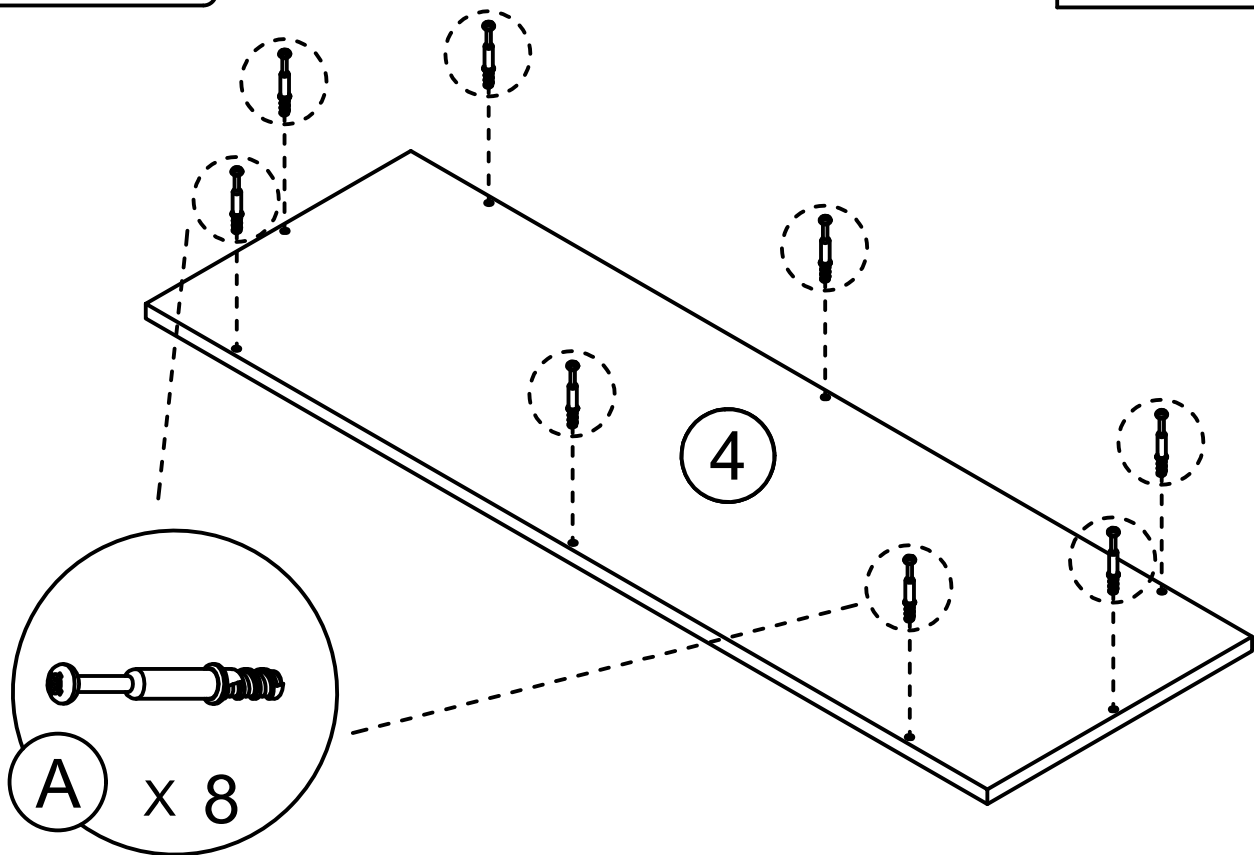
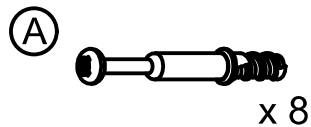

Step 4

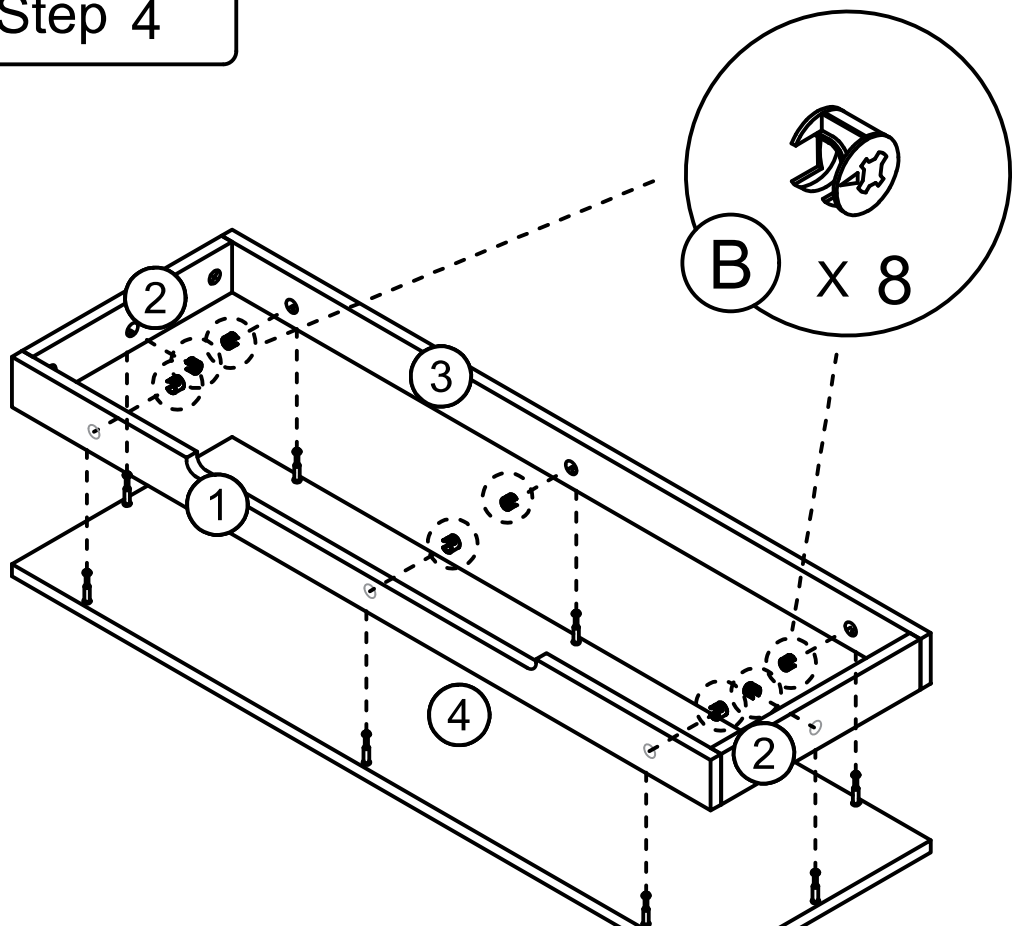

# Step 5

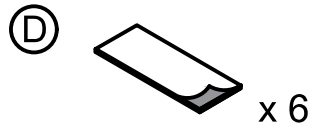

Tear off release paper and stick the black foot pad on the board

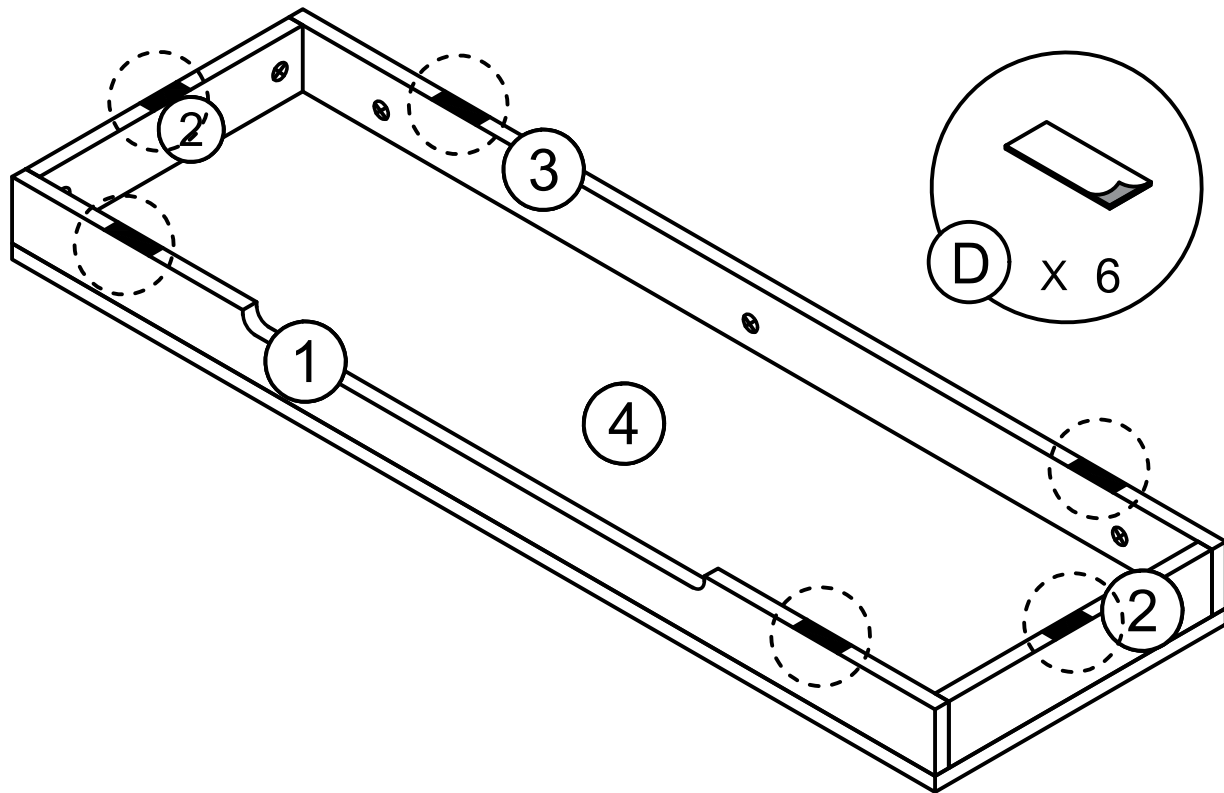

# Step 6

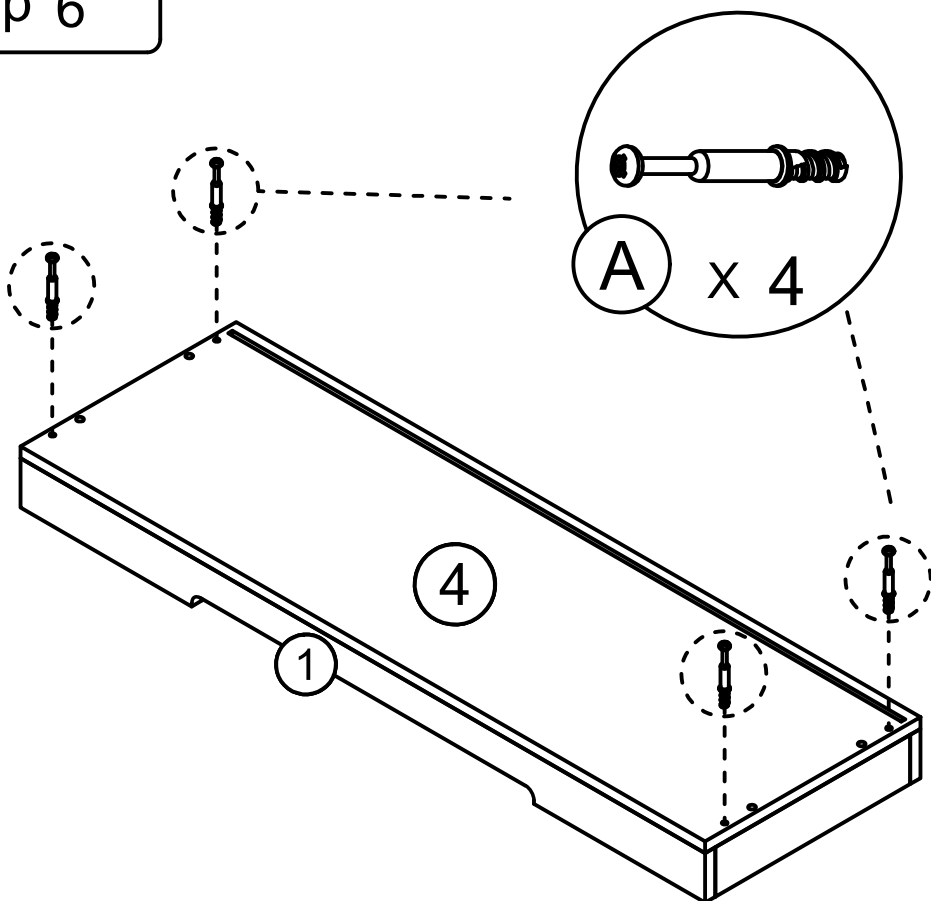
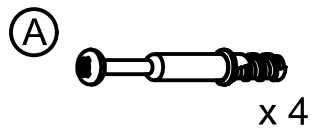

Step 7

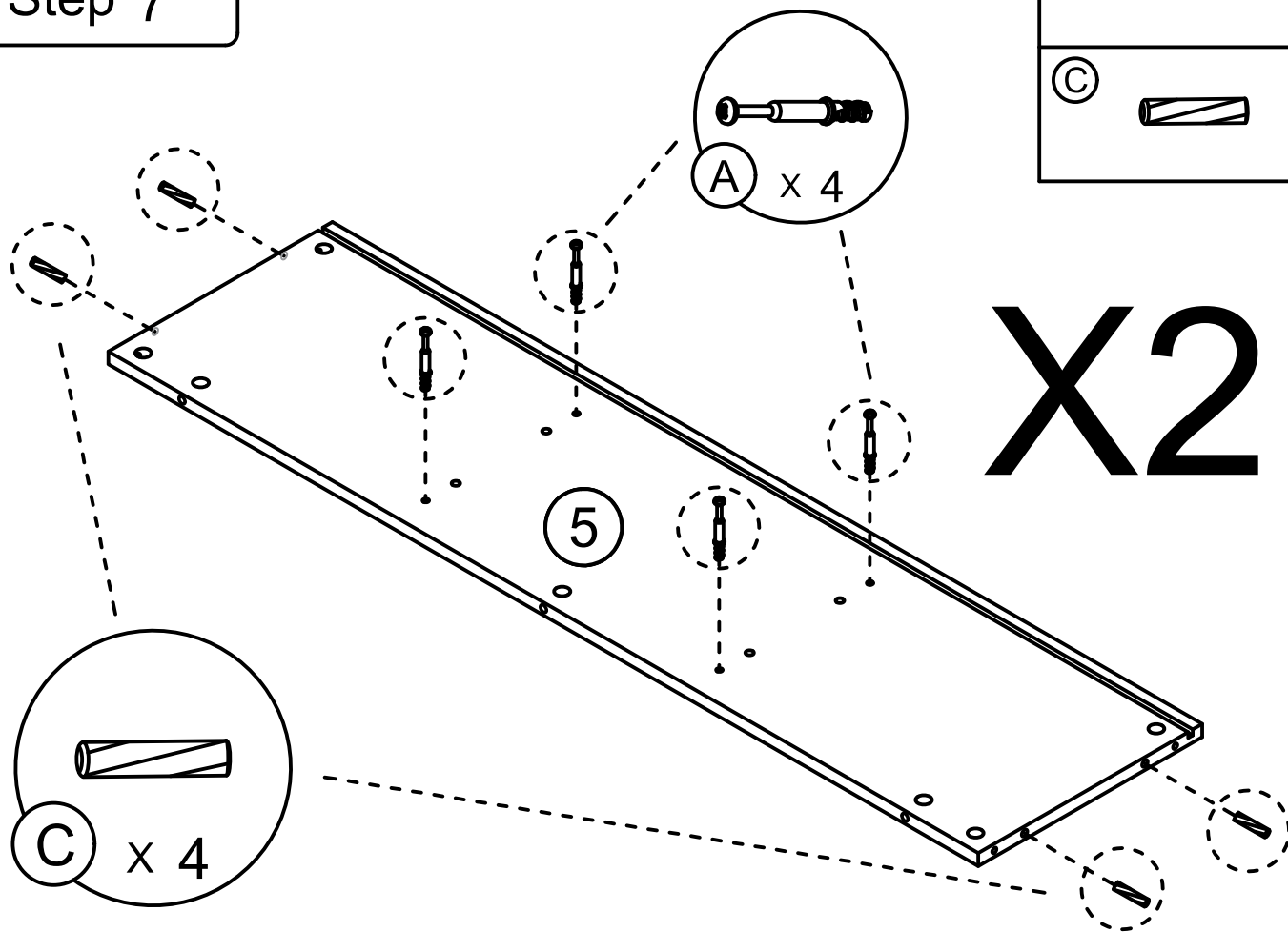
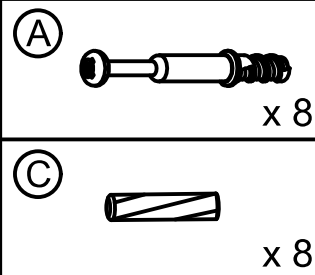

Step 8

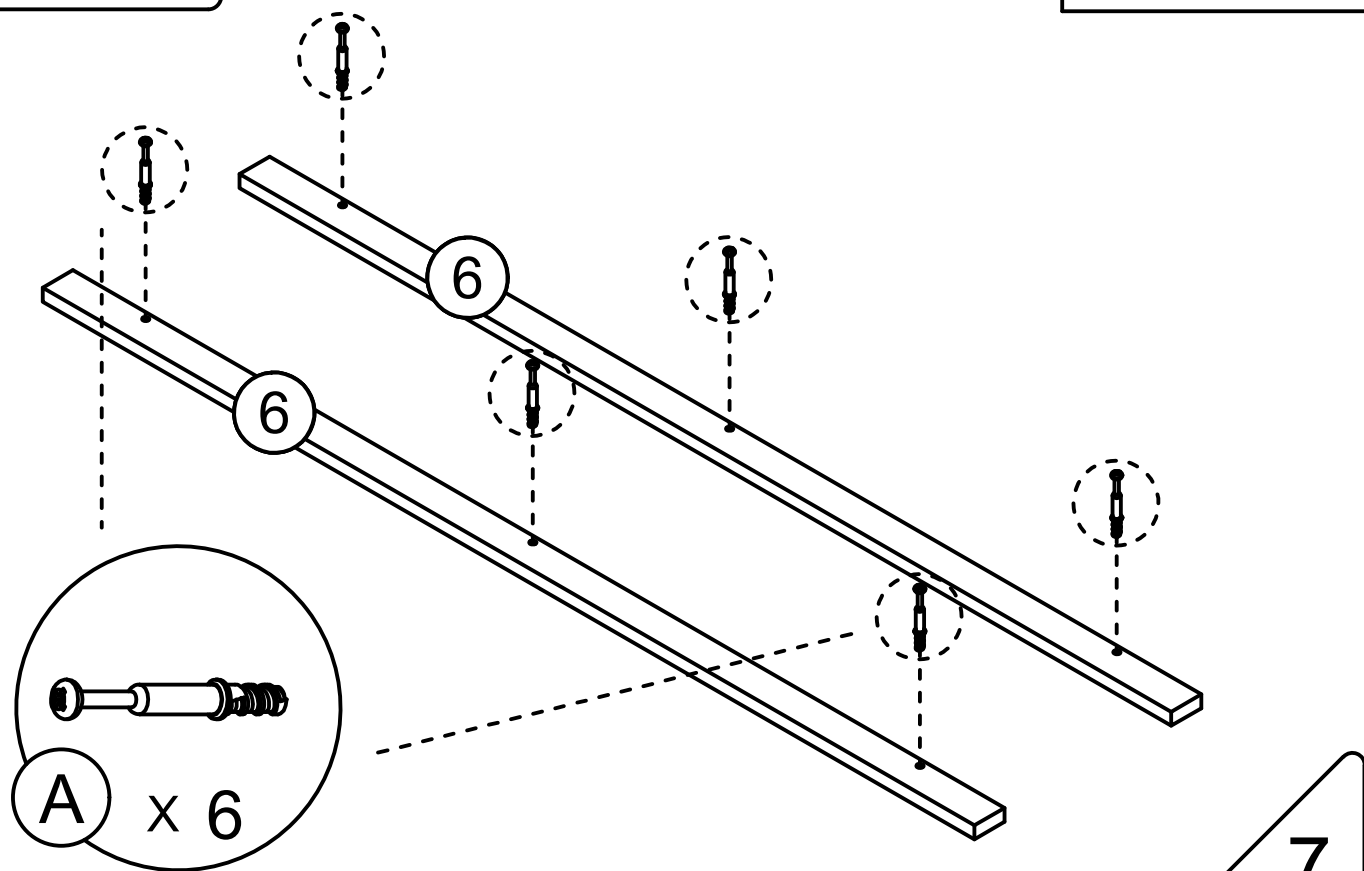
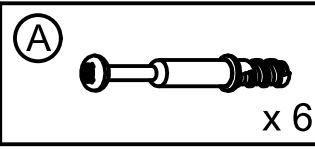

Step 9

(B)



x 6

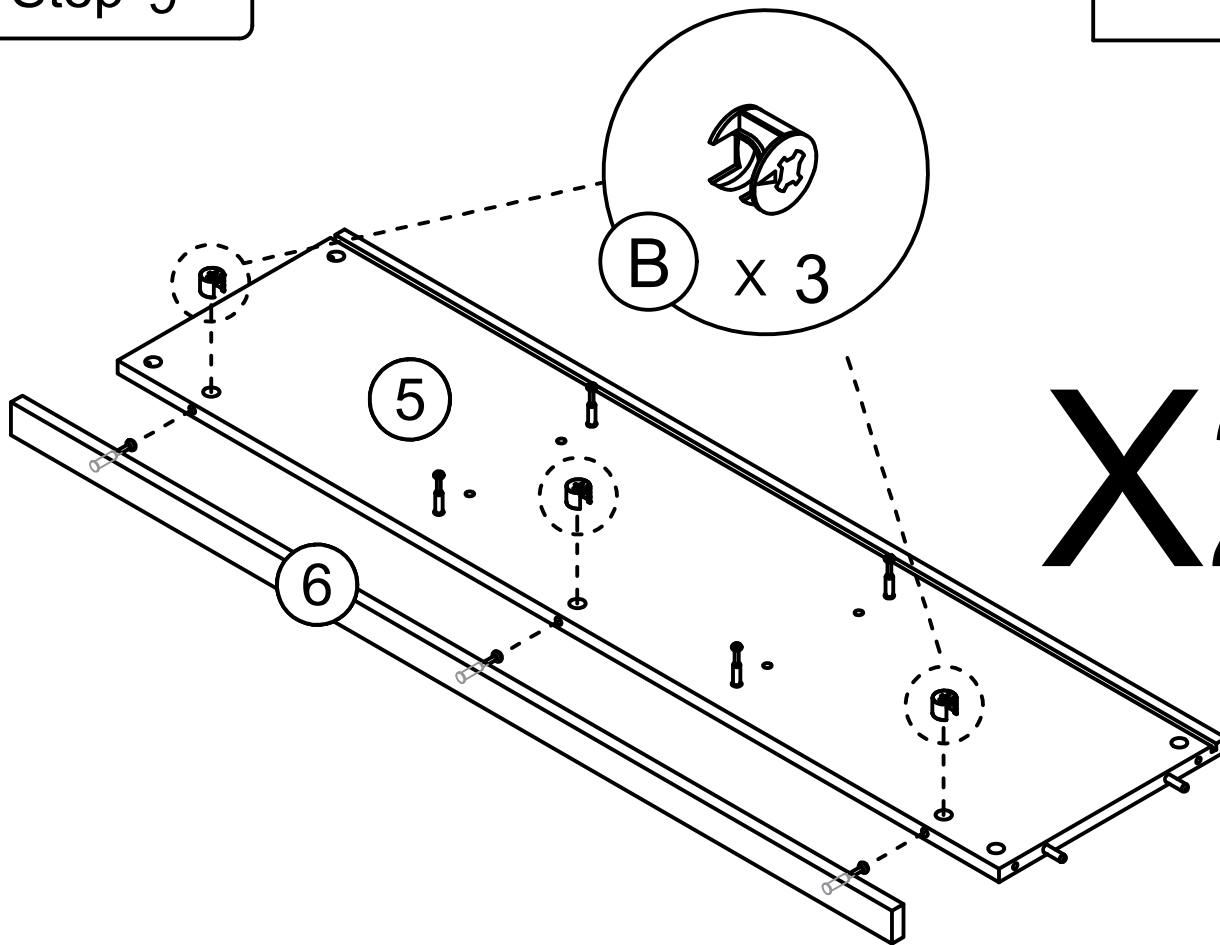

X2

Step 10

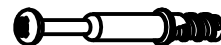

(A)

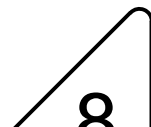
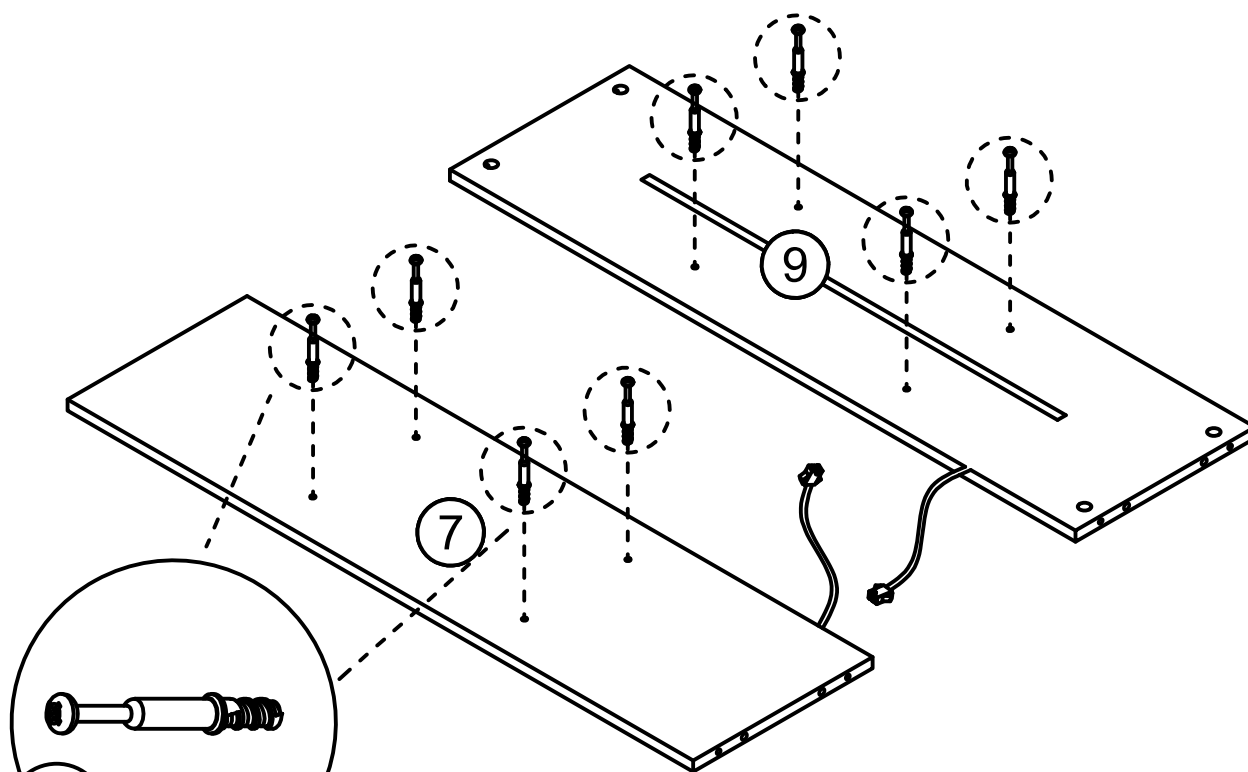

x 8



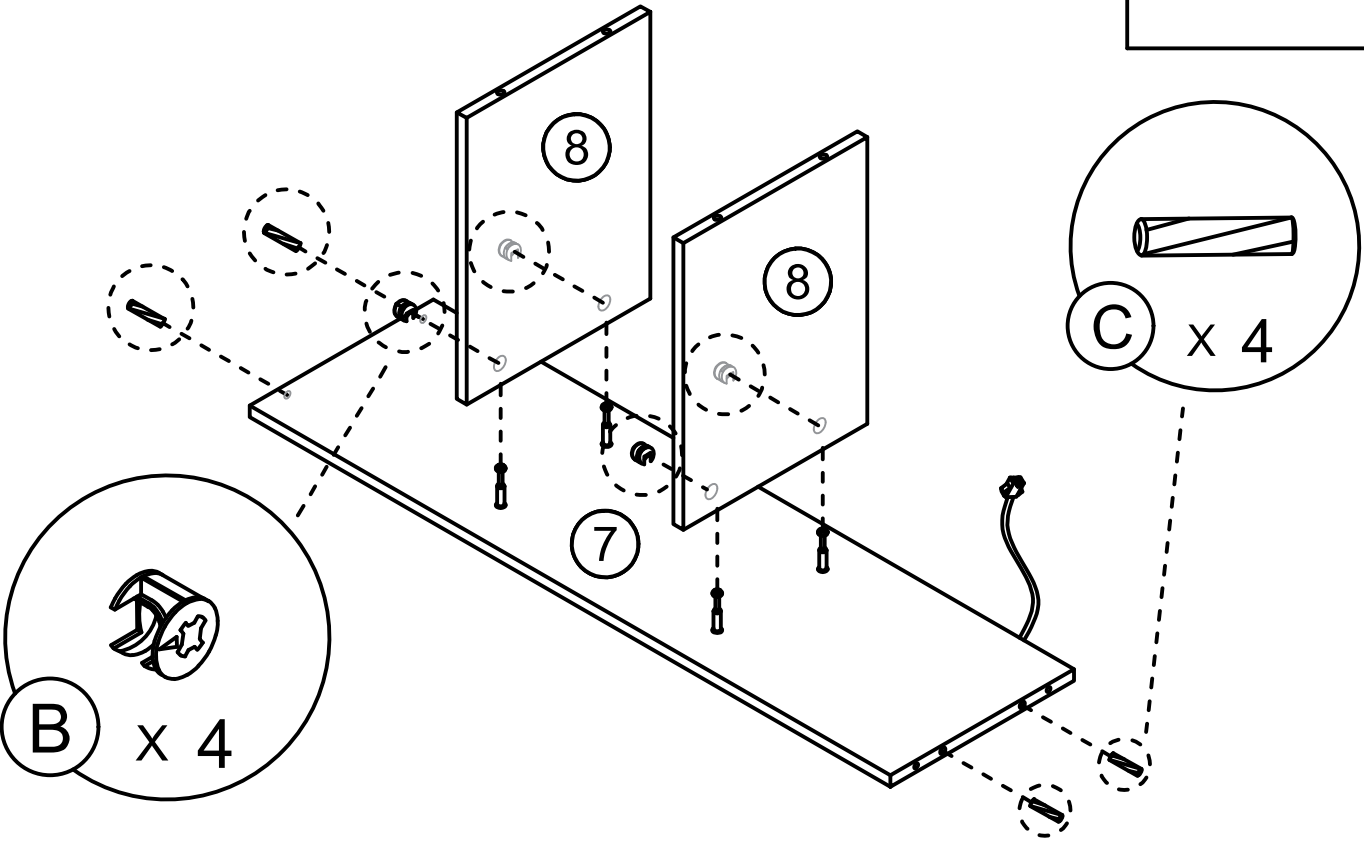

Step 11

- (B)  x 4
- (C)  x 4



Step 12

- (B)  x 4
- (C)  x 4

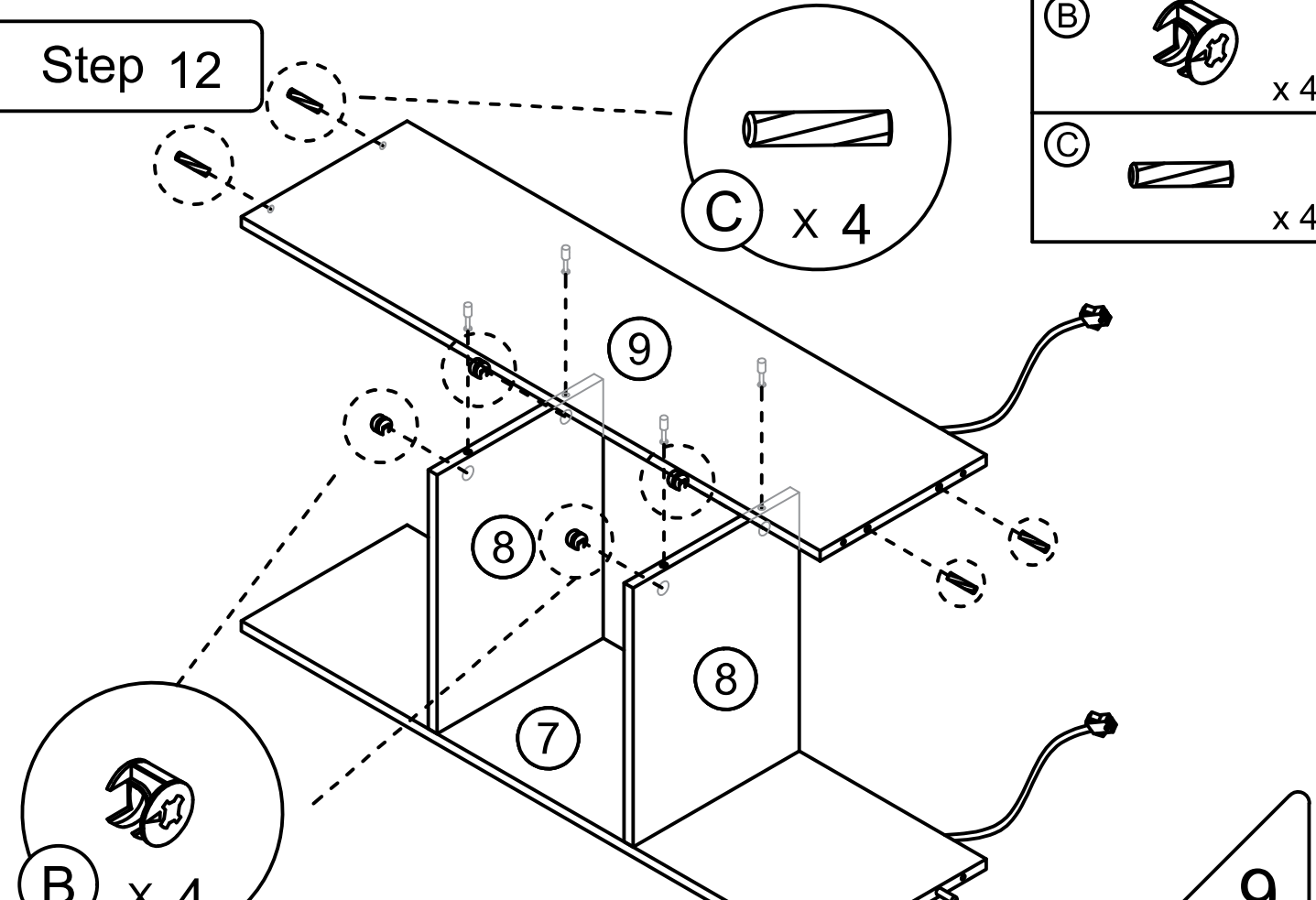

Step 13

(B)  x 4

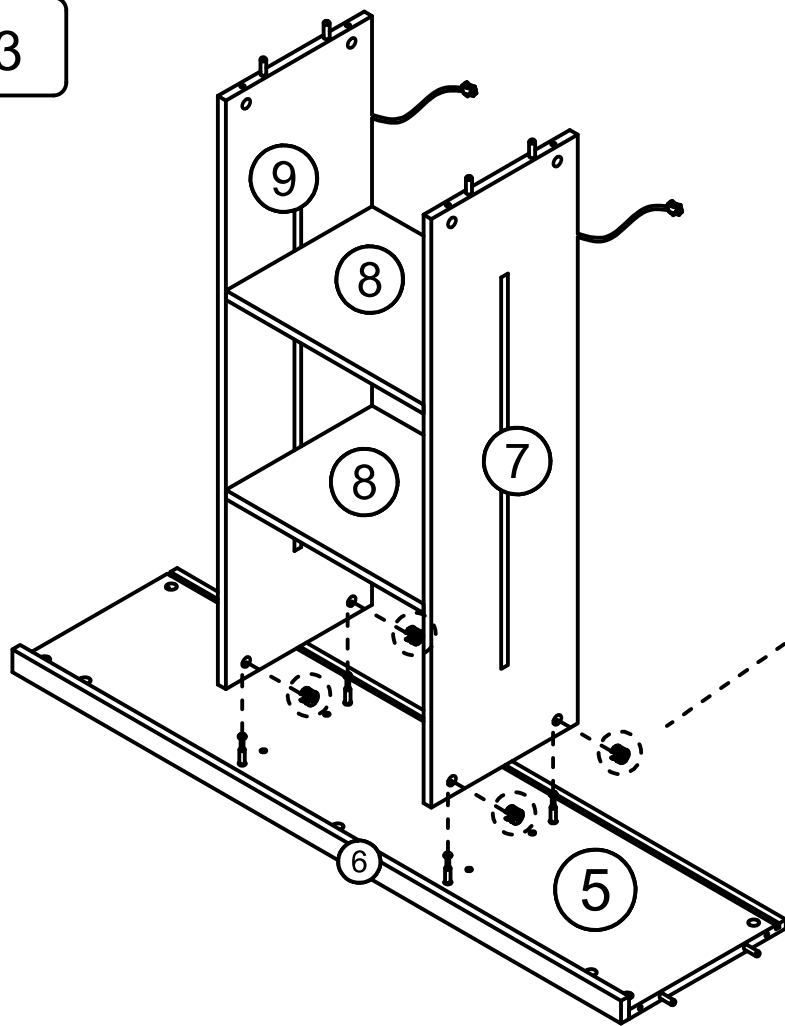

Step 14

(B)  x 4

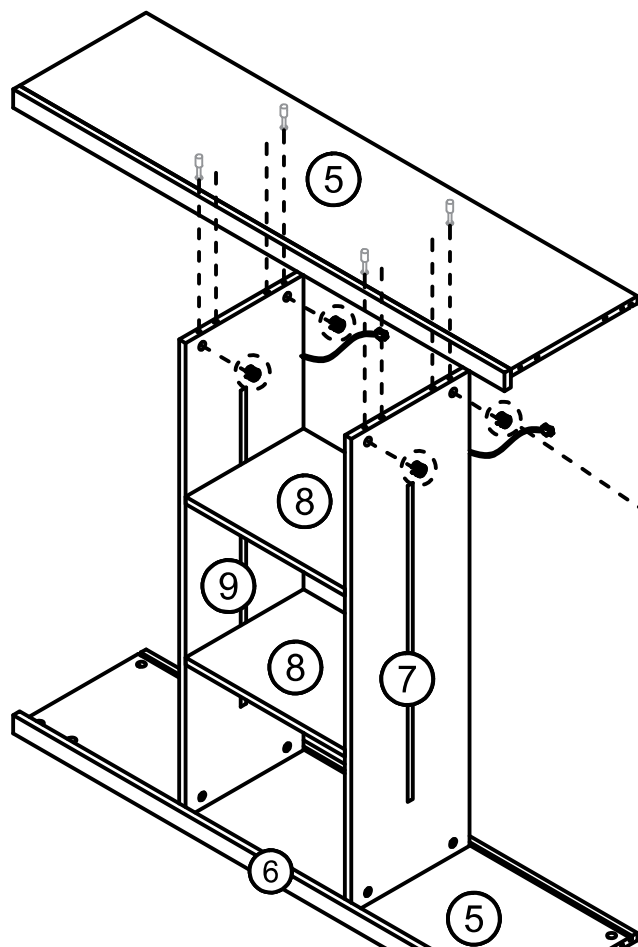

Step 15

Ⓑ x 4

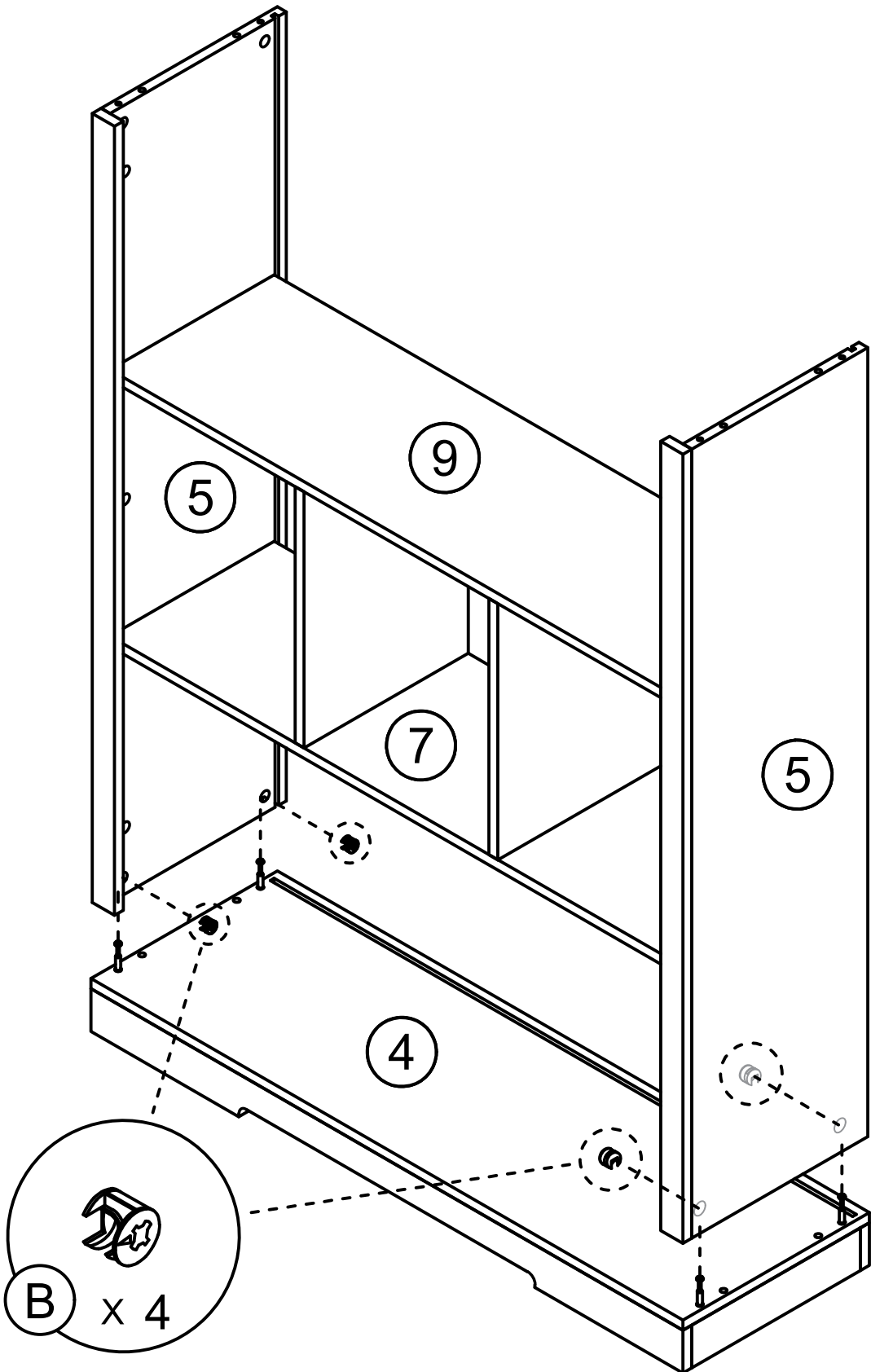

Step 16

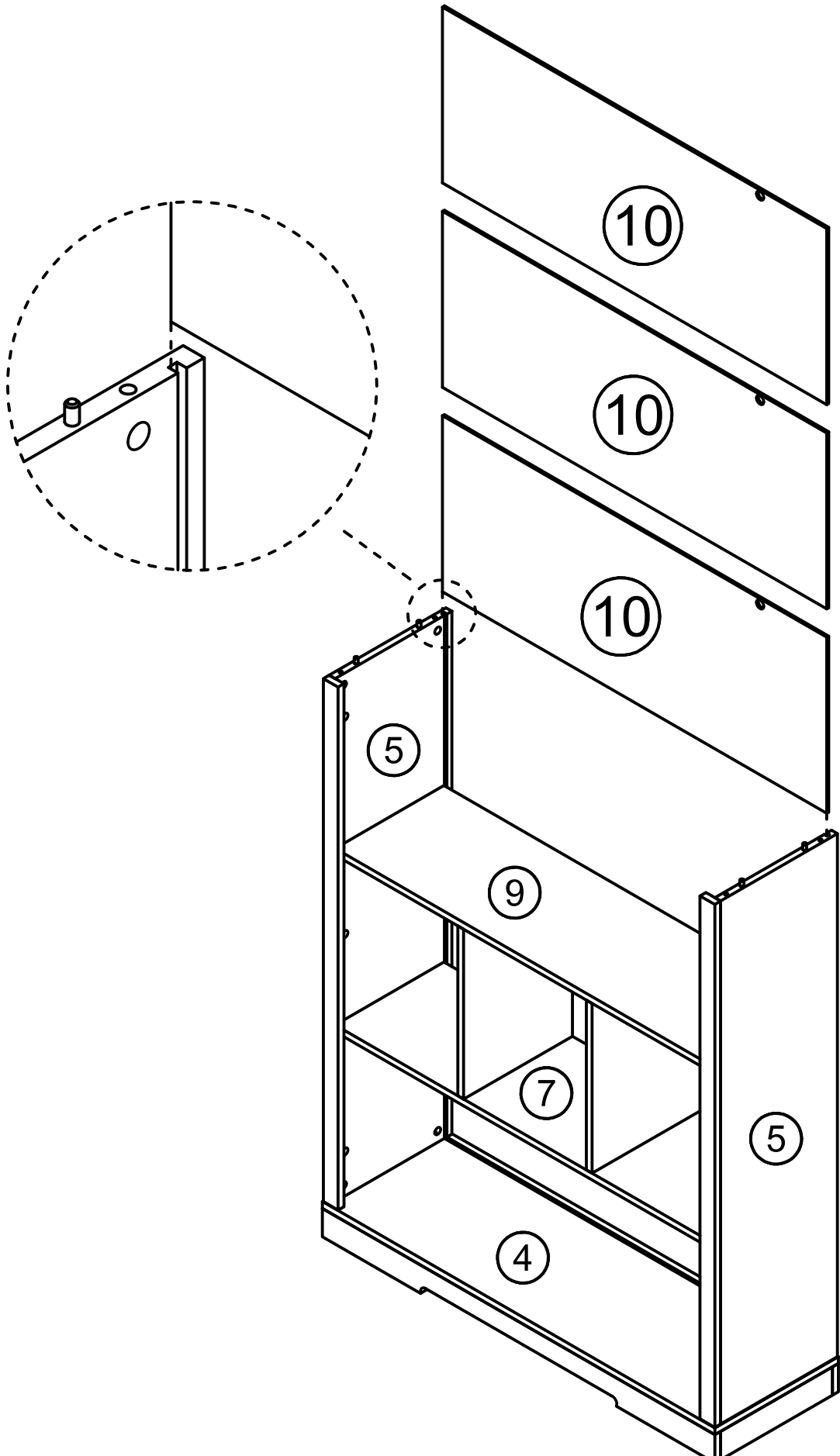

Step 17

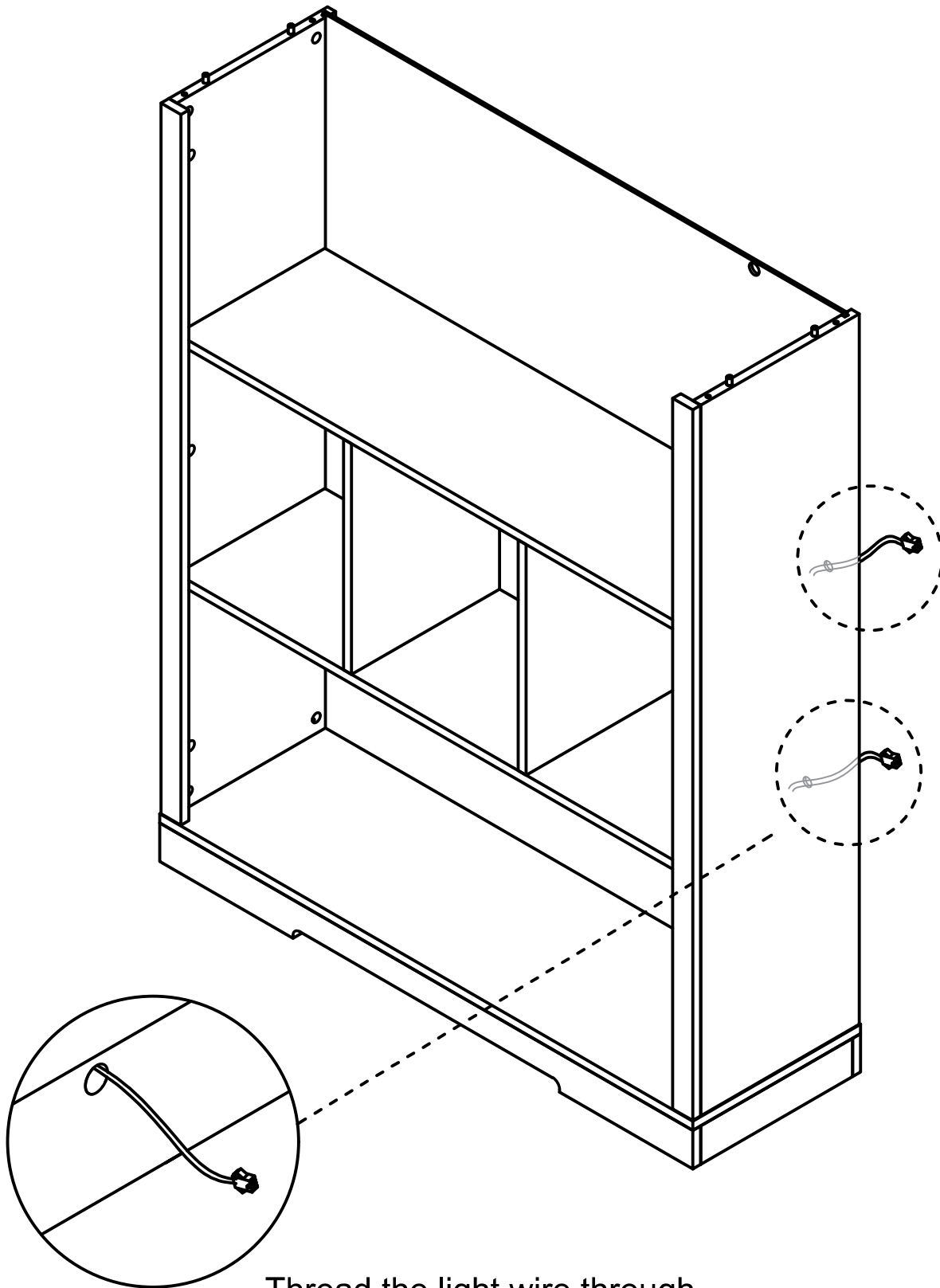

Thread the light wire through  
the back panel hole

Step 18

(A)

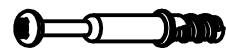

x 4

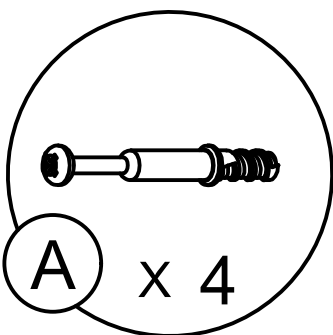
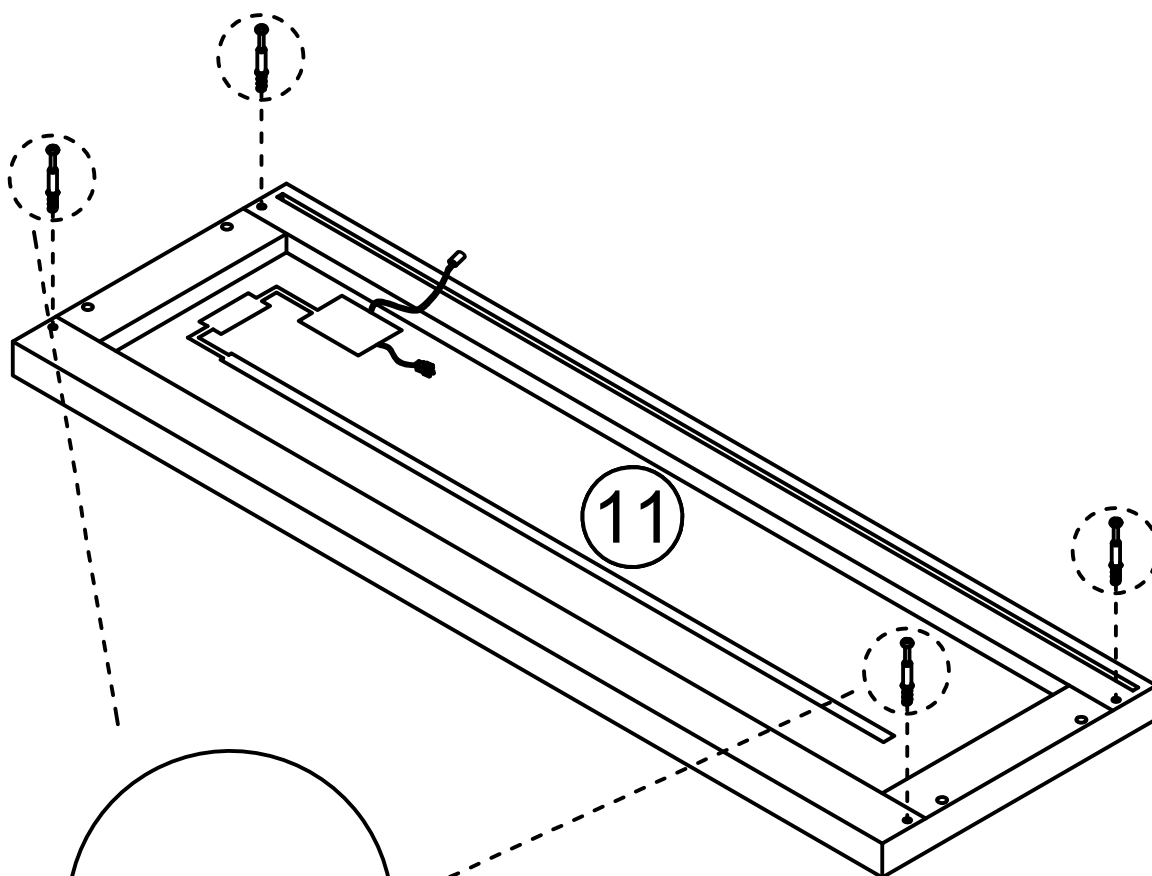

A x 4

Step 19

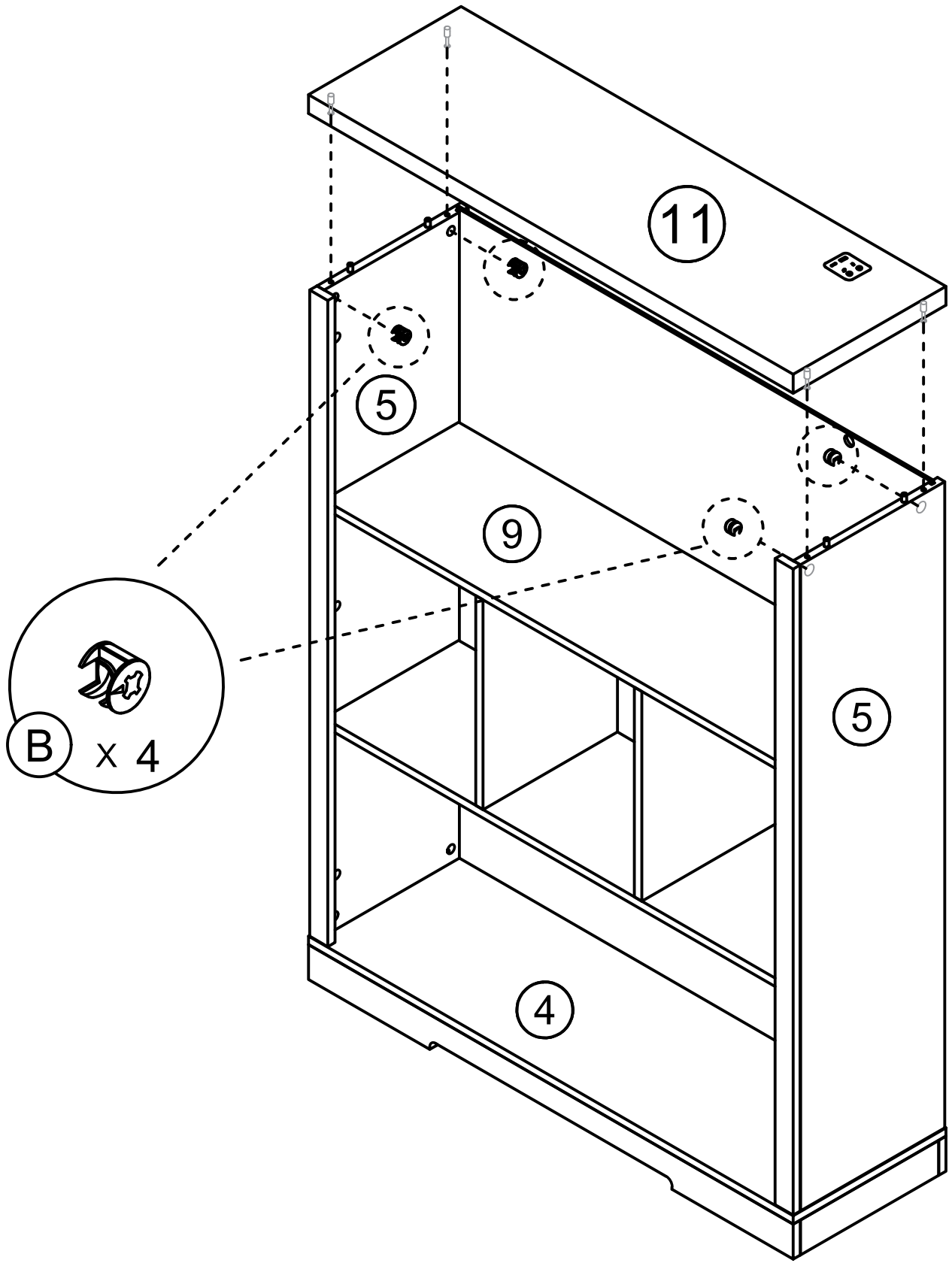

(B)  x 4



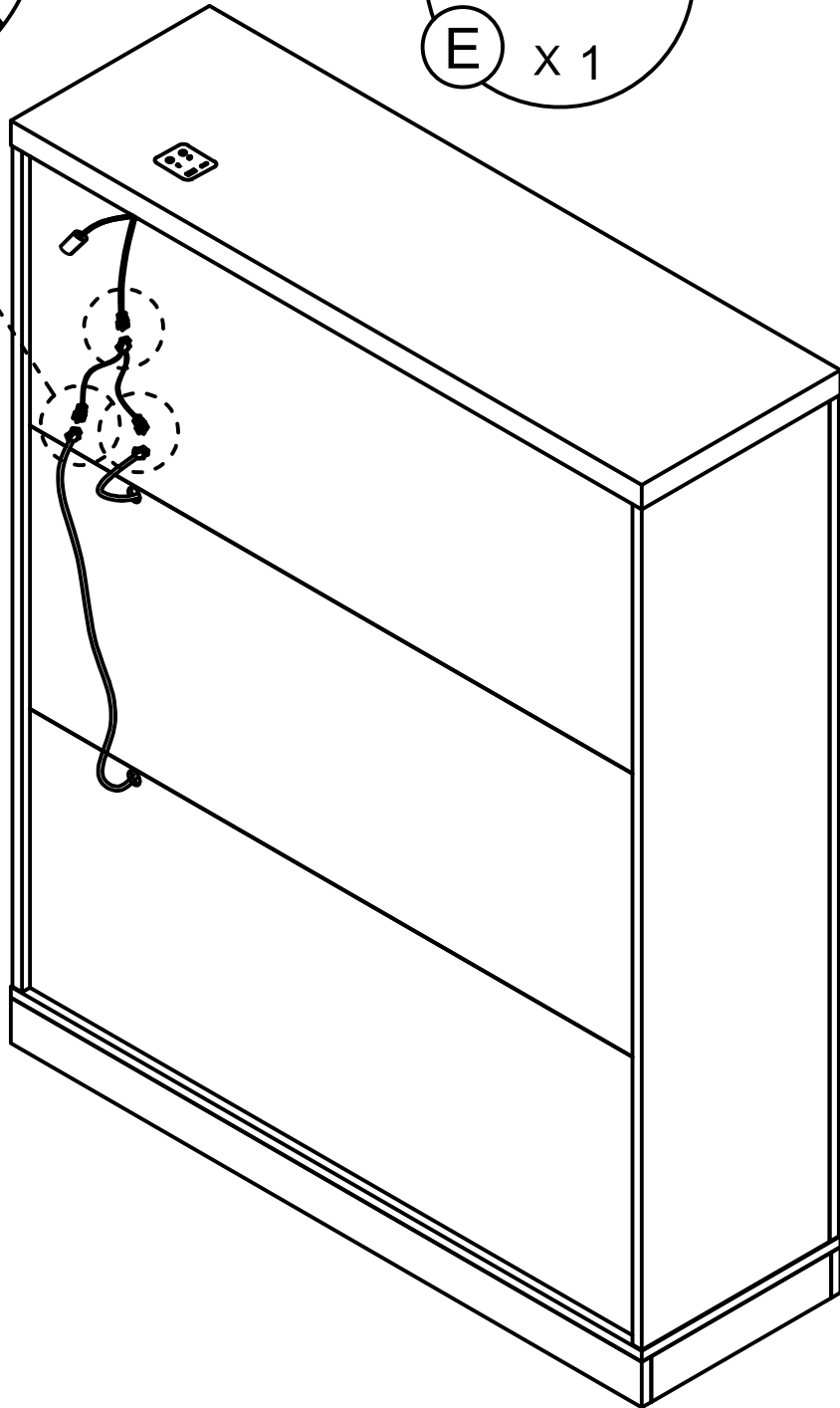
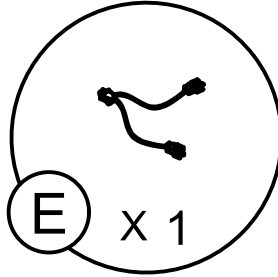
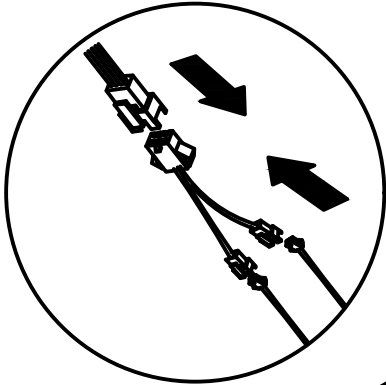
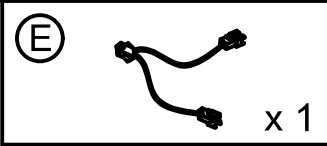

Step 20



Step 21

(F)  x10  x10

(F)  x10  x10

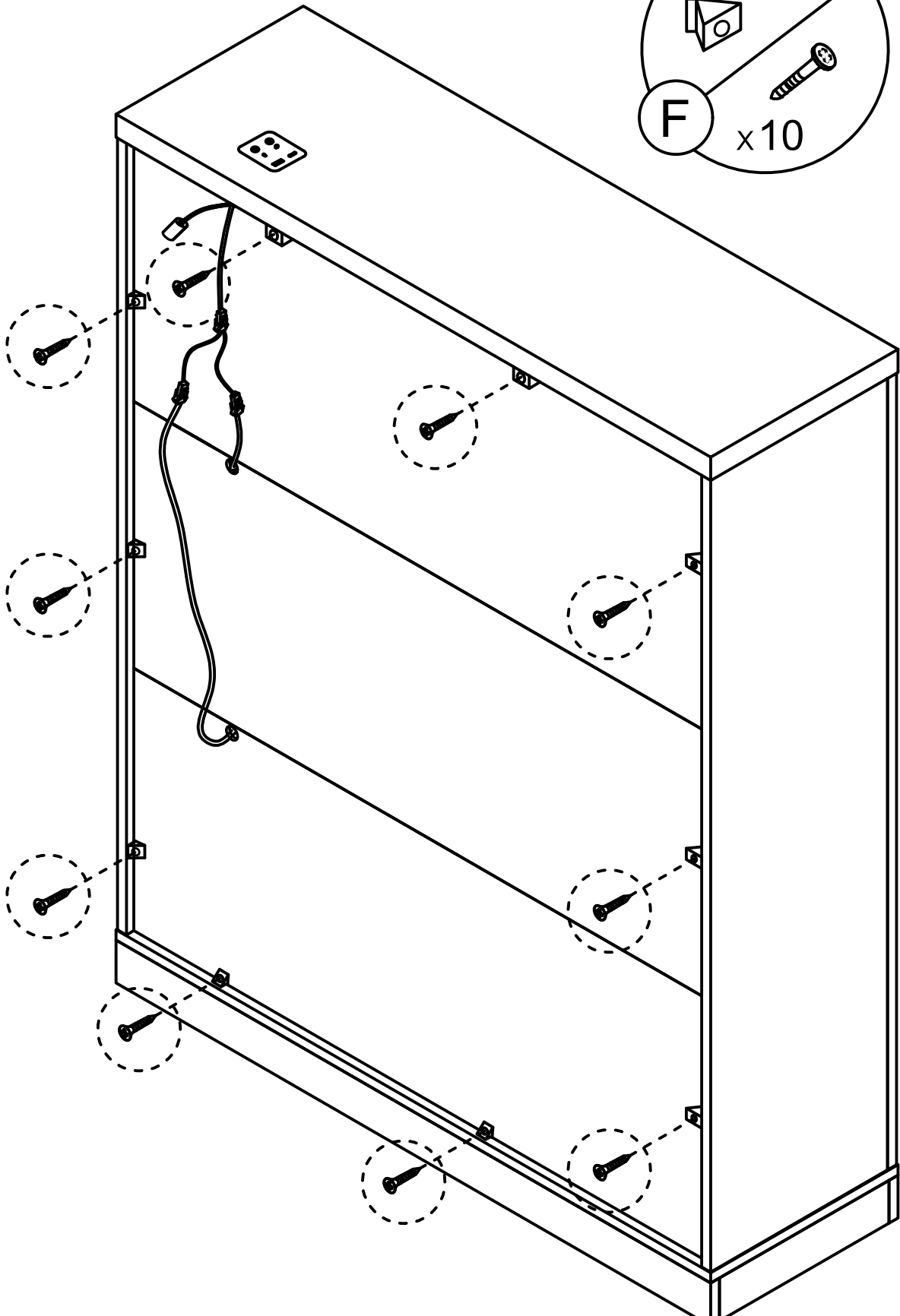

# Step 22

Ⓒ



x 4

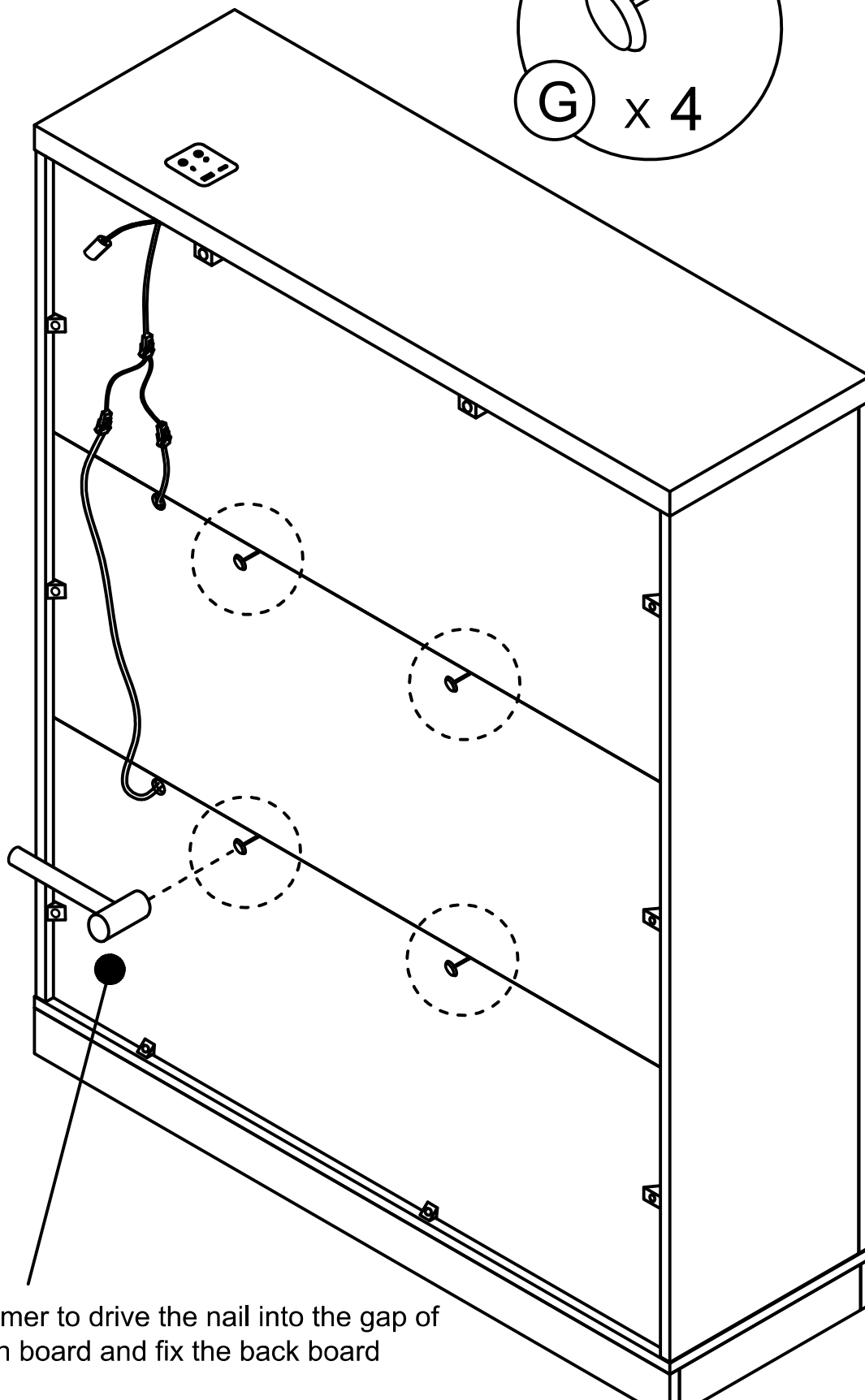
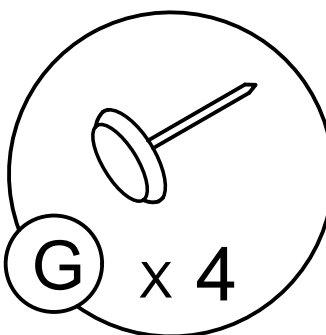

Use a hammer to drive the nail into the gap of the wooden board and fix the back board

# Step 23

**Wall Mount**

+

Drill the hole after measuring and marking position.

Wall

Wall

Wall

- (H) L-shaped bracket x2
- Round washer x4
- 3.5x14mm screw x2
- 4x45mm screw x2

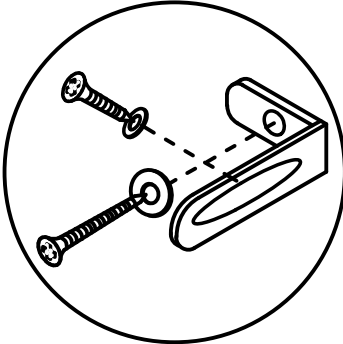

Install as required

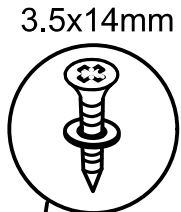
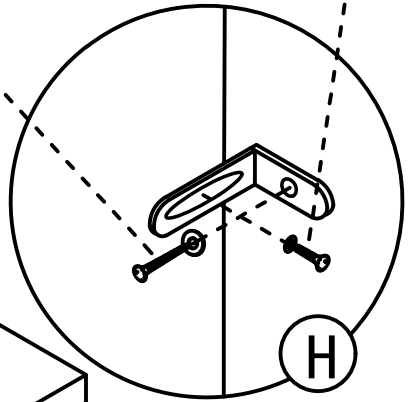
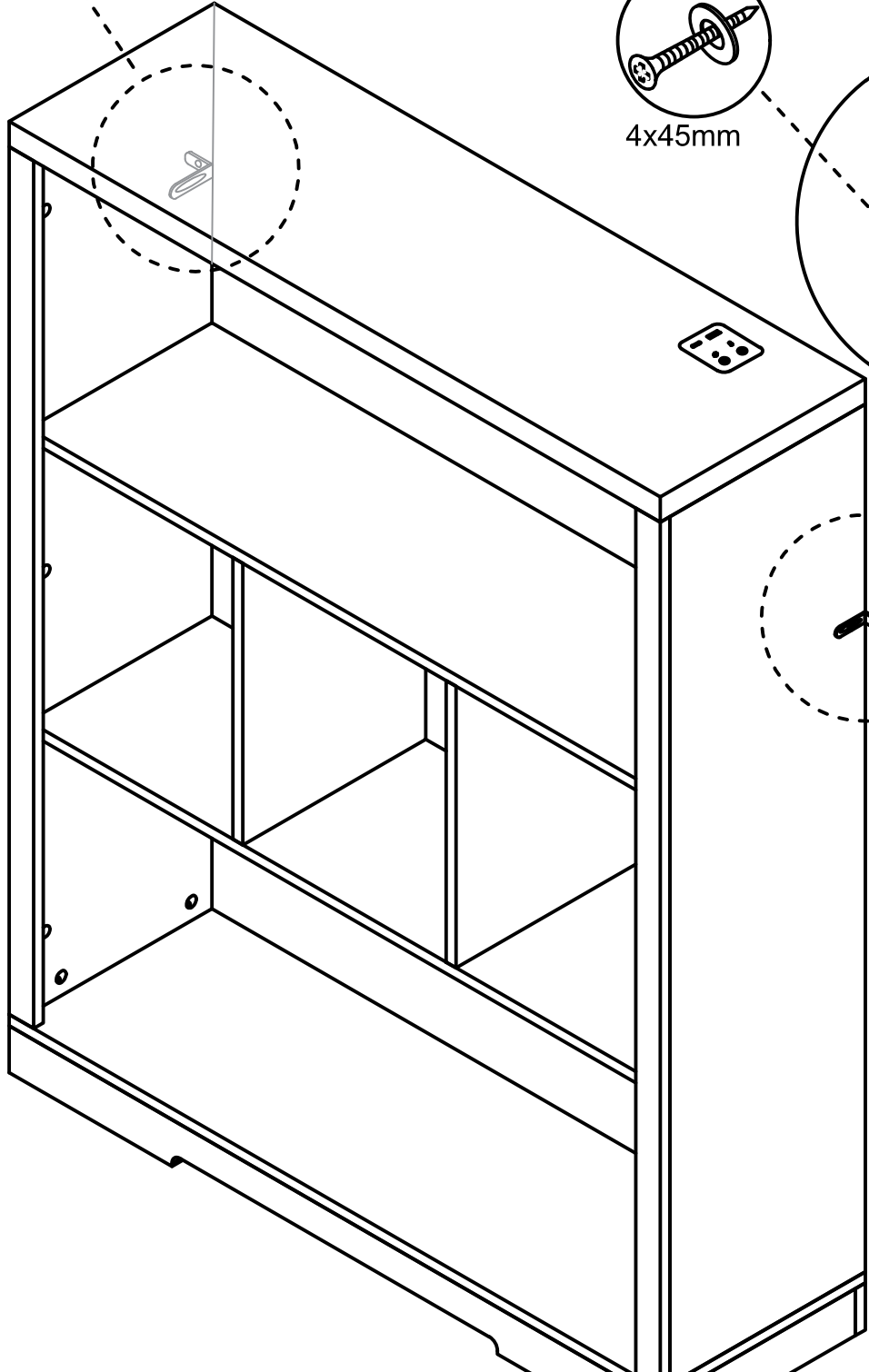

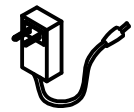

Step 24

wall

