

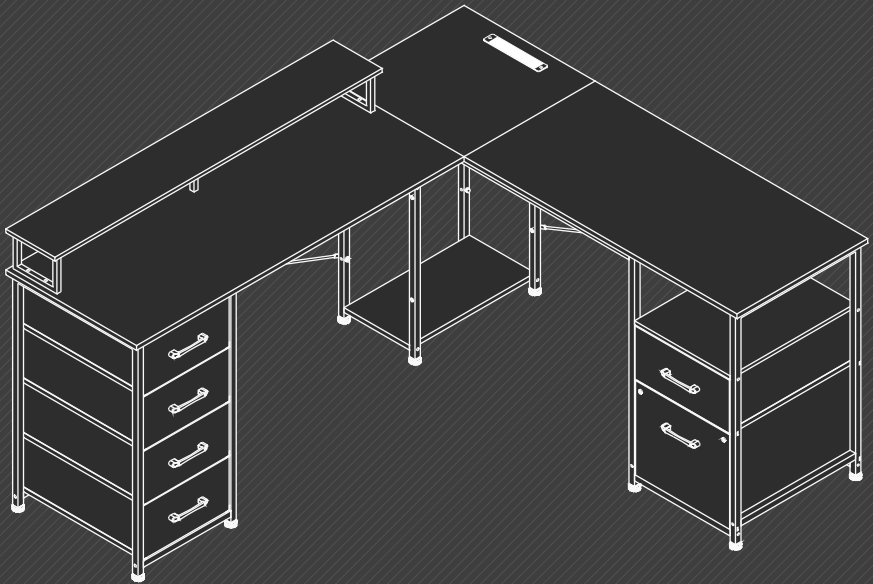

L SHAPED DESK



USER MANUAL



Contents

TOPIC

PAGE

01	SAFETY INSTRUCTIONS	01-02
	1-1 Thank You For Choosing Our Product	01
	1-2 Precautions	02

02	INSTALLING MODULES	03-51
	2-1 Disassembly Diagram	03
	2-2 Parts List	04-05
	2-3 Assembly Instructions	06-51

03	CUSTOMER SERVICE	52-54
	3-1 30-Day Return Policy	52-54
	3-2 1-Year Warranty	52-54
	3-3 Quick Response Within 24 Hours	52-54

04	PROBLEMS YOU MAY ENCOUNTER	55-59
	4-1 Problems You May Encounter	55-59

Thank You For Choosing Our Product

Before assembly, please read this USER MANUAL first, and check according to Parts List to make sure all parts are included.

Feel free to contact us if you have any concerns or questions about your product, we are always ready to help. Your satisfaction is our first priority!

Vielen Dank für den Kauf unseres Produkts.

Bitte lesen Sie vor dem Zusammenbau zuerst diese Bedienungsanleitung und überprüfen Sie anhand der Teileliste, ob alle Teile enthalten sind.

Zögern Sie nicht, uns zu kontaktieren, wenn Sie Bedenken oder Fragen zu Ihrem Produkt haben. Wir sind immer bereit, Ihnen zu helfen. Ihre Zufriedenheit ist unsere erste Priorität!

Merci d'avoir choisi notre produit.

Avant l'assemblage, veuillez d'abord lire ce manuel d'utilisation et vérifier en fonction de la Liste des pièces pour vous assurer que toutes les pièces sont incluses.

N'hésitez pas à nous contacter si vous avez des soucis ou des questions sur votre produit, nous sommes toujours prêts à vous rendre service. Votre satisfaction est notre première priorité!

¡Gracias por escoger nuestro producto!

Antes del montaje, lea este MANUAL DEL USUARIO primero y verifique de acuerdo con la Lista de Piezas para asegurarse de que todas las piezas estén incluidas.

Si tiene alguna pregunta, no dude en contactarnos, siempre estaremos a su disposición. ¡Su satisfacción es nuestra principal prioridad!

Grazie per aver scelto il nostro prodotto.

Prima del montaggio, leggere questo MANUALE UTENTE e controllare secondo l'elenco delle parti per assicurarsi che tutte le parti siano incluse.

Non esitare a contattarci se hai dubbi o domande sul tuo prodotto, siamo sempre pronti ad aiutarti. La tua soddisfazione è la nostra prima priorità!

Precautions

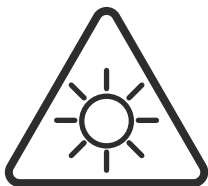

- Avoid long-term direct sunlight exposure.
- Vor langer Sonneneinstrahlung schützen.
- Évitez une exposition prolongée au soleil.
- Evitar la exposición prolongada al sol.
- Evitare l'esposizione prolungata al sole.

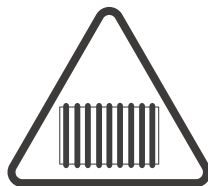

- Keep away from heat.
- Von Hitze fernhalten.
- Tenez à l'écart de la chaleur.
- Alejar de fuente de calor.
- Tenere lontano dal calore.



- Keep away from sharp objects.
- Vorsicht mit scharfen Objekten.
- Disposez des objets pointus avec soin.
- Coloque con cuidado los objetos afilados.
- Collocare con cura oggetti appuntiti.

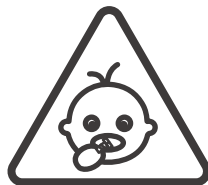

- Keep infants/children away from assembly parts to avoid choking and suffocation.
- Montage Teile von Babys/Kleinkindern fernhalten.
- Gardez les bébés / enfants à l'écart des pièces de montage pour éviter tout risque d'avalement.
- Mantenga las piezas de montaje lejos de bebés y niños en caso de ingestión.
- Tenere i neonati / bambini lontani dalle parti di montaggio in caso di ingestione.



- Keep away from corrosive substances.
- Von ätzenden Stoffen fernhalten.
- Évitez les substances corrosives.
- Manténgase alejado de sustancias corrosivas.
- Manténgase alejado de sustancias corrosivas.

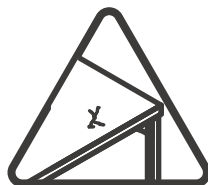

- Pay attention to avoid over-tightening fasteners, or they may induce cracking within the board.
- Festigkeit der Schrauben regelmäßig überprüfen.
- Vérifiez régulièrement la fermeté des vis et des autres pièces métalliques.
- Compruebe la firmeza de los tornillos y otras piezas metálicas.
- Controllare regolarmente la solidità delle viti e delle altre parti metalliche.







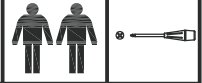

Disassembly Diagram

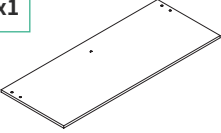
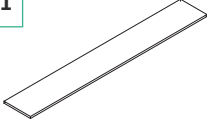
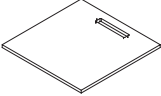
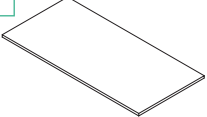
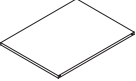
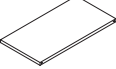
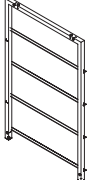
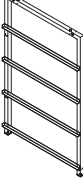

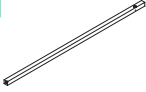
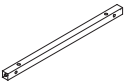
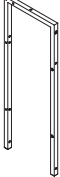
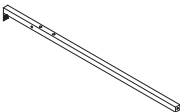



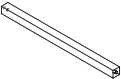
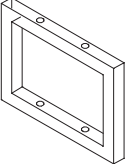
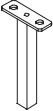





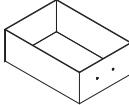
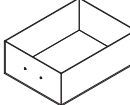
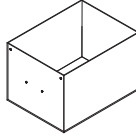
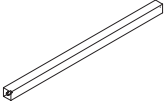



Parts List

For ease and safety, we recommend two people for assembly.

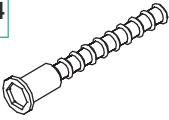
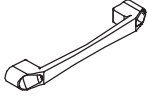
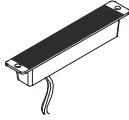
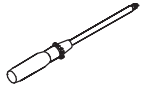

A x1 	B x1 	C x1 	D x1 
E x1 	F x2 	G x1 	H x1 
I x2 	J x2 	K x1 	L x2 
M x2 	N x2 	O x2 	P x2 
Q x2 	R x2 	S x1 	T x1 

Parts List

<p>U x1</p> 	<p>V x4</p> 	<p>W x1</p> 	<p>X x1</p> 	
<p>Y x2</p> 	<p>1 x14</p>  <p>2 Spares</p>	<p>2 x16</p>  <p>M6x10</p> <p>2 Spares</p>	<p>3 x44</p>  <p>M6x30</p> <p>3 Spares</p>	
<p>4 x2</p>  <p>M4</p> <p>1 Spare</p>	<p>5 x9</p>  <p>M6x23</p> <p>1 Spare</p>	<p>6 x14</p>  <p>M4x8</p> <p>2 Spares</p>	<p>7 x3</p>  <p>ST4x12</p> <p>1 Spare</p>	
<p>8 x14</p>  <p>M6.3x50</p> <p>2 Spares</p>	<p>9 x6</p> 	<p>10 x1</p> 	<p>11 x1</p> 	
<p>12 x7</p>  <p>M6</p> <p>1 Spare</p>	<p>13 x2</p> 	<p>14 x2</p> 	<p>15 x1</p> 	<p>16 x1</p> 



Static Color Button



Dynamic Mode Button



S / B

Speed & Brightness
and Power Button

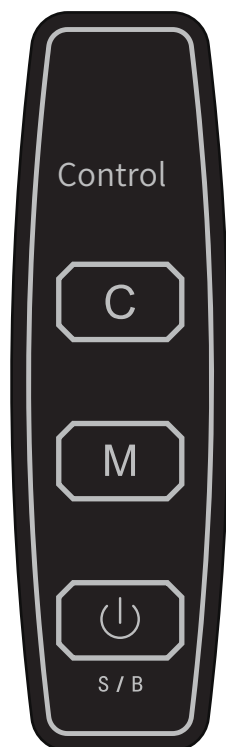

STATIC COLOR BUTTON

Press this button once to switch to the static color mode, and then each pressing can change the color.

DYNAMIC MODE BUTTON

Press this button once to switch to the dynamic mode effect, and then each pressing can change the dynamic mode.

Press this button for more than 2s to switch to the demo mode; In the demo mode, the strip will automatically cycle through various dynamic modes.

SPEED & BRIGHTNESS AND POWER BUTTON

A. In the static mode, press this button to adjust the brightness of the light bar; each press can switch to a brightness level.

B. In the dynamic mode, press this button to adjust the dynamic mode speed; each press can switch to a speed level.

C. Press and hold this button to shut it down when the strip is on. Press this button to turn it on when the strip is off.

The product has a power-off memory function; the strip can restore the color, brightness, and mode in the next power-on.

Assembly Instructions



Note that this desk has 4 different installation options, please refer to following infos to find right installation steps.

Mode 1: 1-14

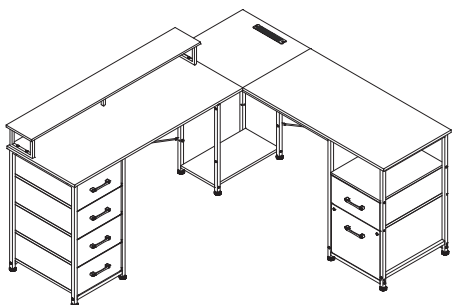

Mode 2: 15-28

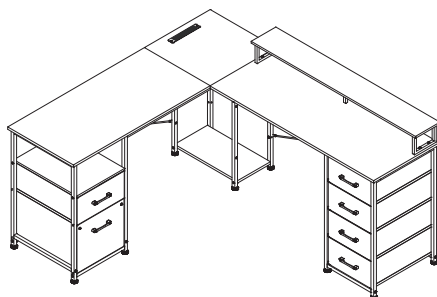

Mode 3: 29-41

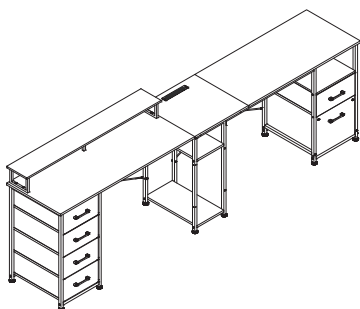

Mode 4: 42-54

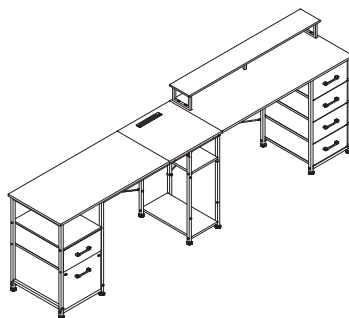

Mode 1: 1-14

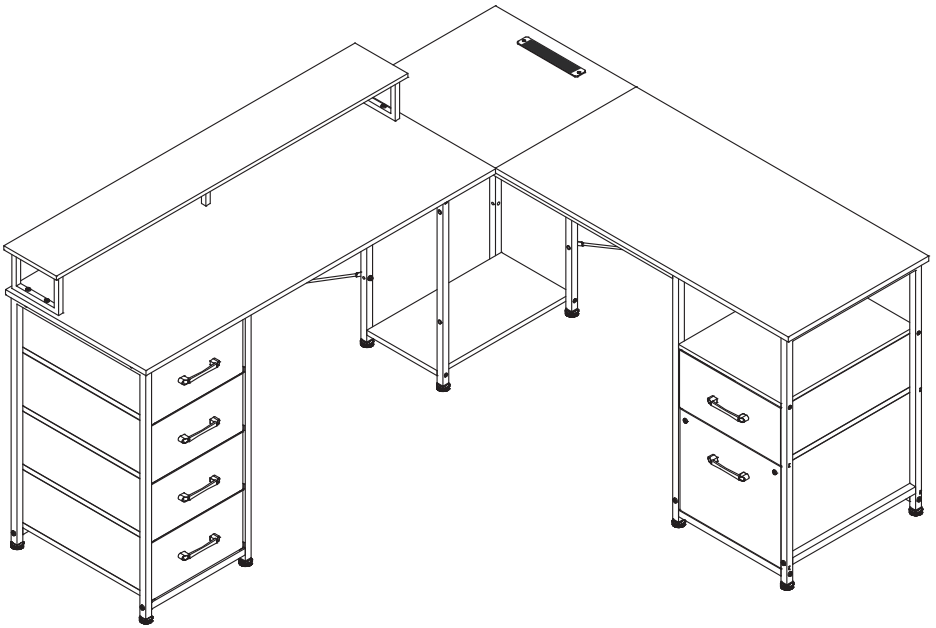

Assembly Instructions

1

Install foot pads ① on desk legs, use screws ③ to assemble Y and N together.

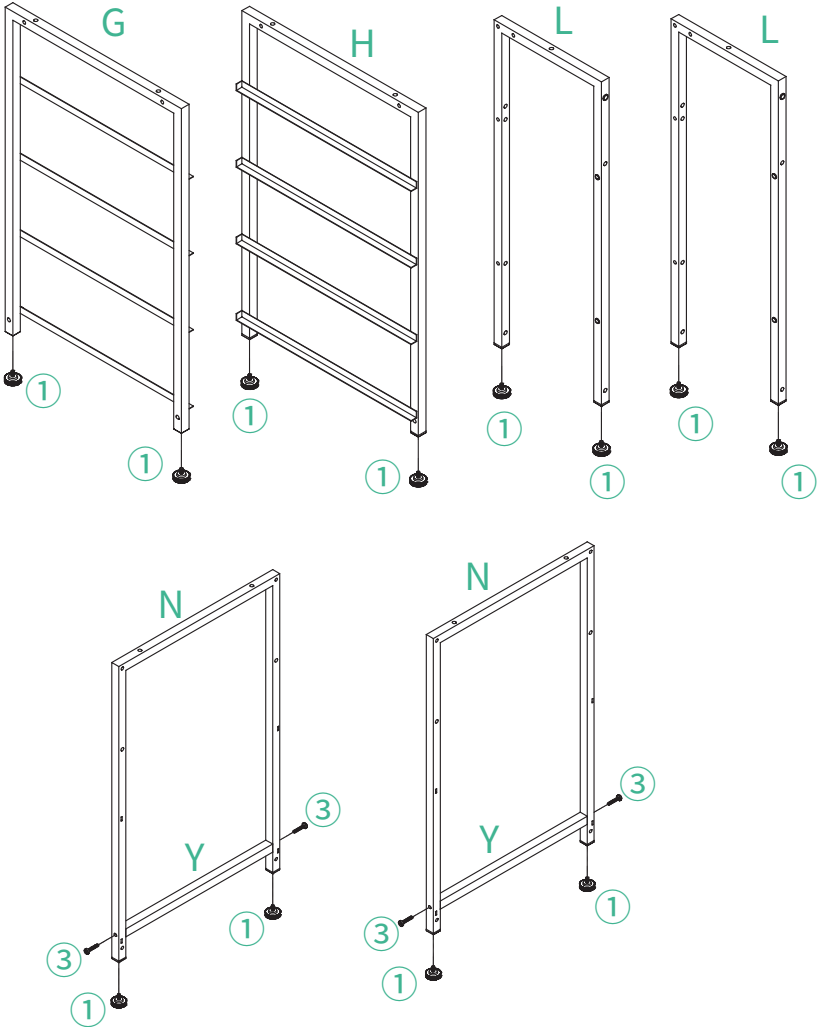

G x1		H x1		L x2		N x2		Y x2		① x12		③ x4		
													④ x1	

Assembly Instructions

2

Determine the installation direction according to the arrow indication. Wrong installation direction will cause installation failure in subsequent steps.

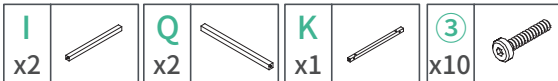
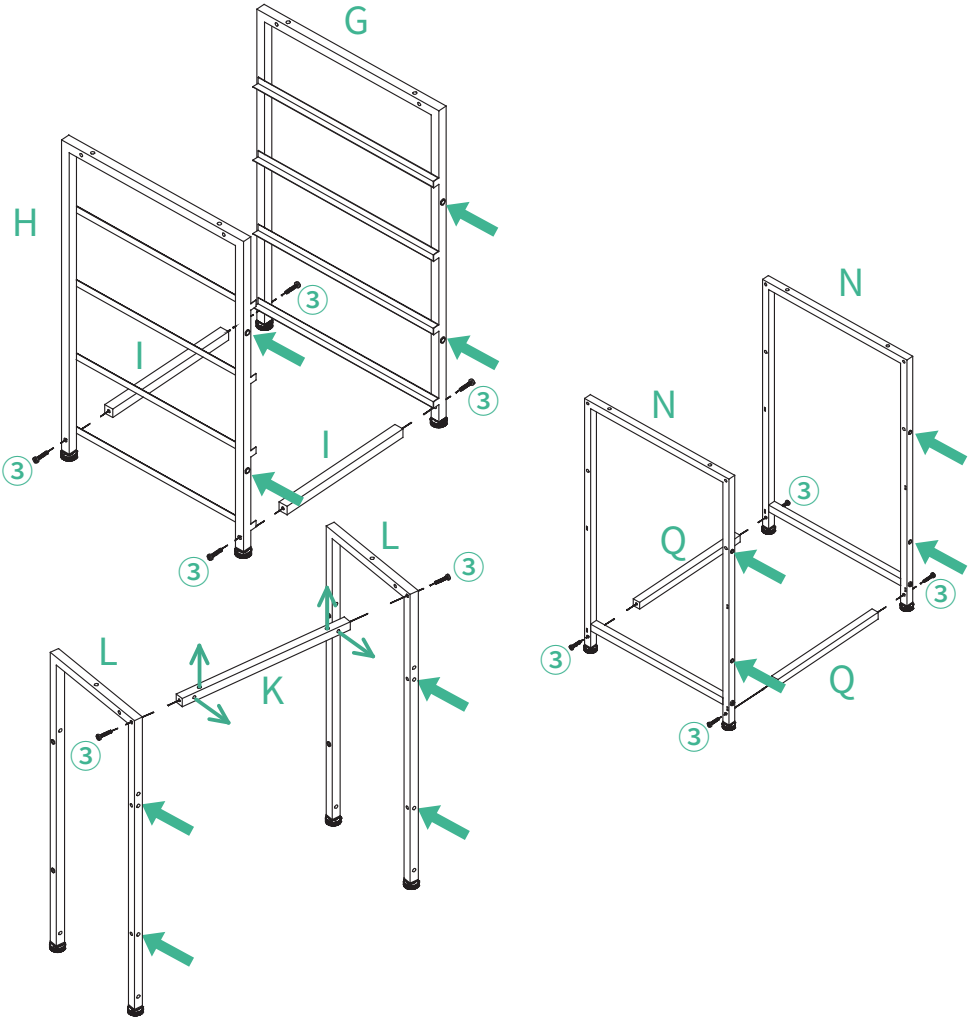

Assembly Instructions

3

Determine the installation direction according to the arrow indication. Screw holes marked by arrows are for supporting bars installation and make sure these holes face the same direction.

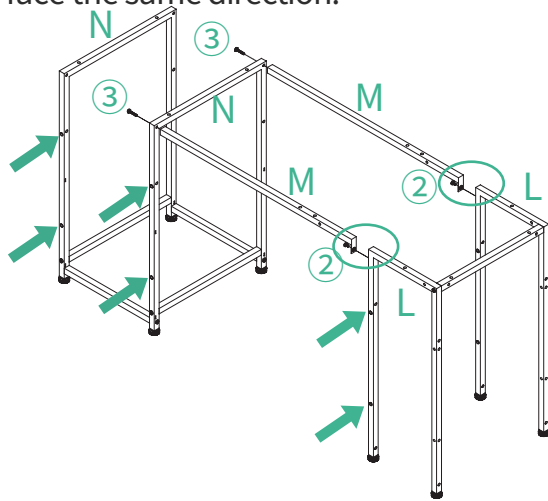

4

Determine the installation direction according to the arrow indication. Screw holes marked by arrows are for supporting bars installation and make sure these holes face the same direction. Determine the installation direction of J as the picture shows.

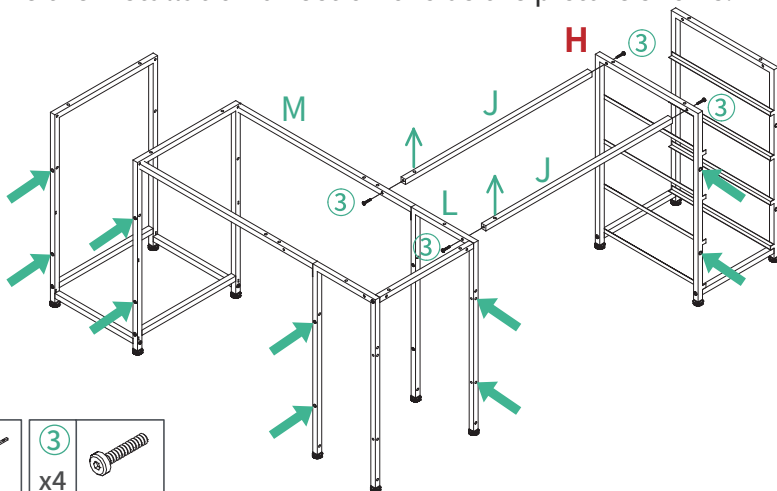

Assembly Instructions

5

Use screws ② & screws ③ & nuts ⑫ to install U and T.

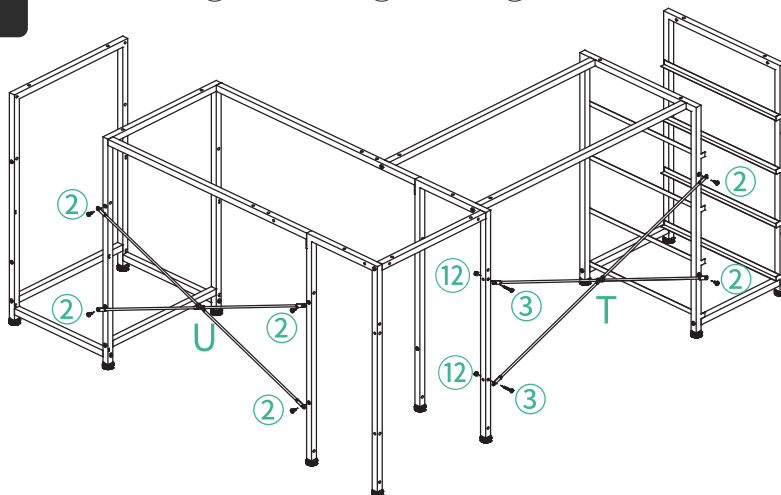

6

Install E on N, install F on L.

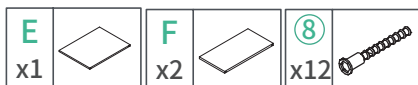
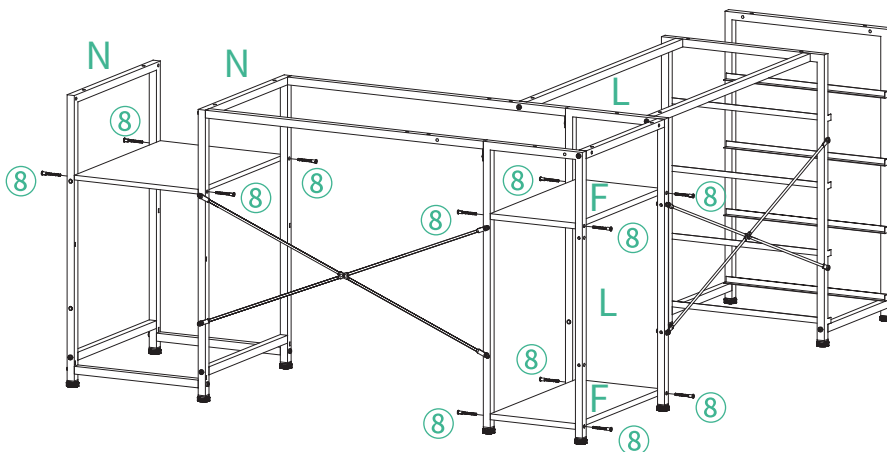

Assembly Instructions

7

Note that board A, C, D must be placed as the picture shows. Insert all the screws into the holes first and make sure boards are aligned, then tighten the screws.

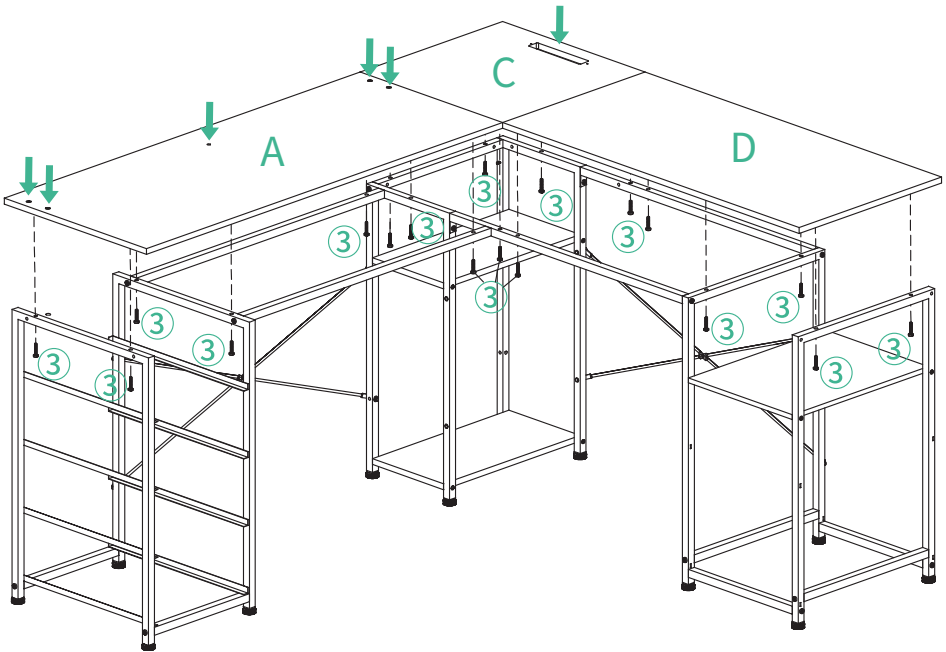

Assembly Instructions

8

Attach the 3M sticker to the light strip, make sure place it on the back of the LED lights.

Use screws ② to install S, use screws ⑤ to install R.

Please note to use right screws, and wrong screws may crack the board.

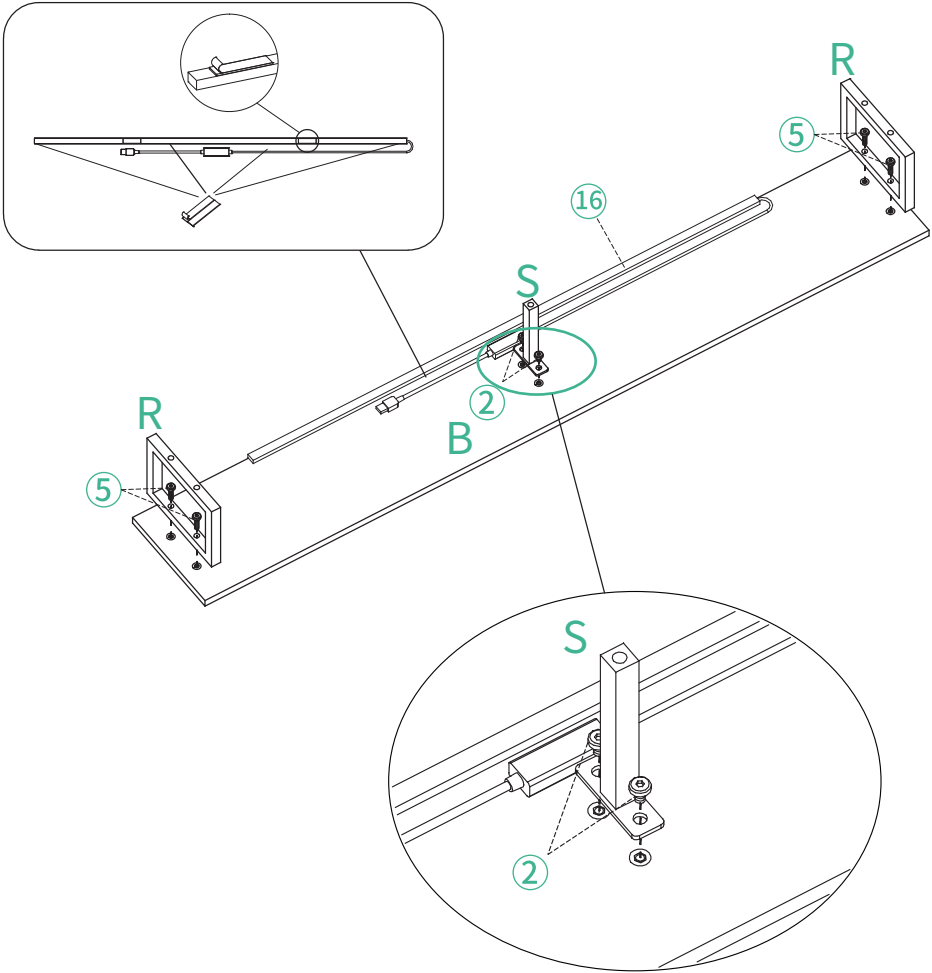

Assembly Instructions

9

Use screws ③ to install S, use screws ⑤ to install monitor shelf, and use screws ⑦ to install ⑩.

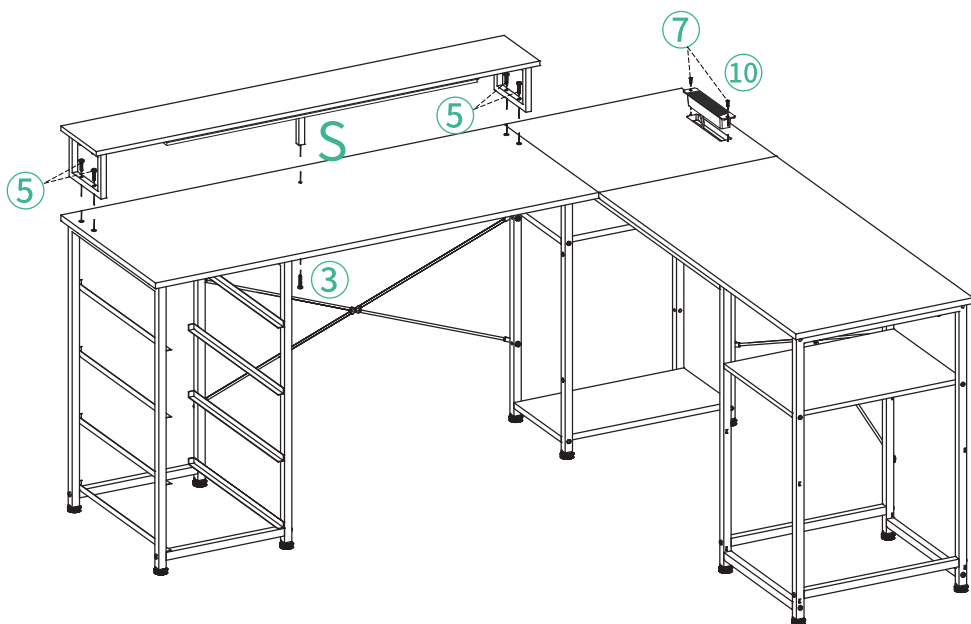

Assembly Instructions

10

Insert drawer rails into the rectangular holes on desk legs as the picture shows.

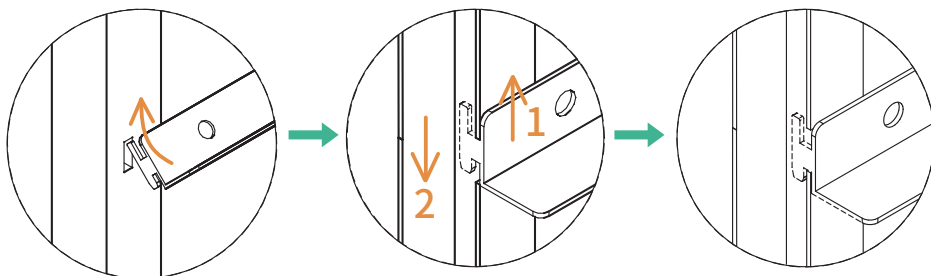
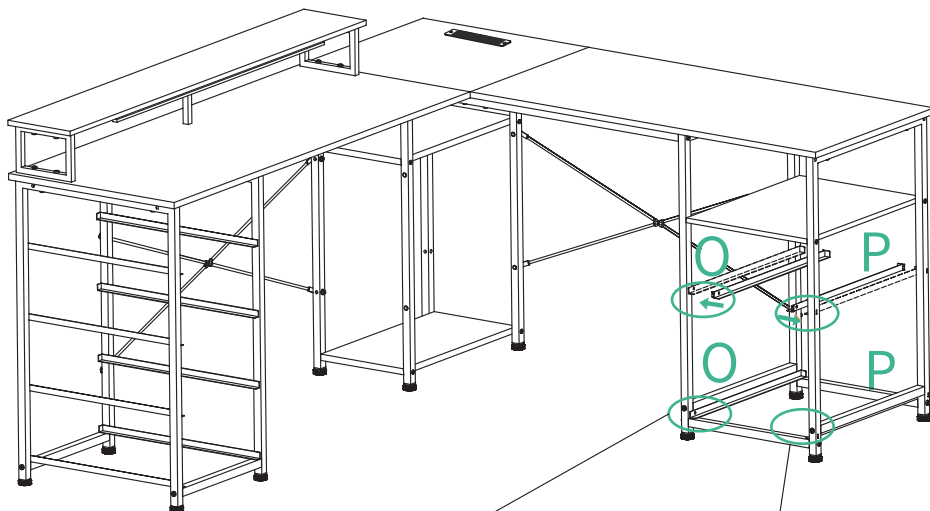

Assembly Instructions

13

Put all drawers in place as the picture shows.

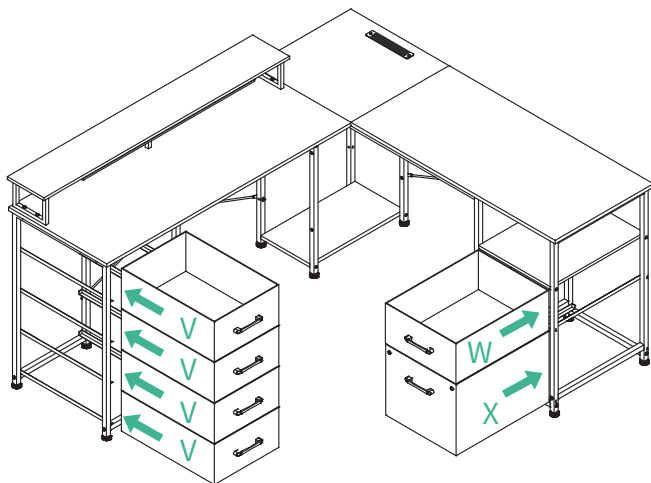

14

Congratulations! You have finished installing the desk.

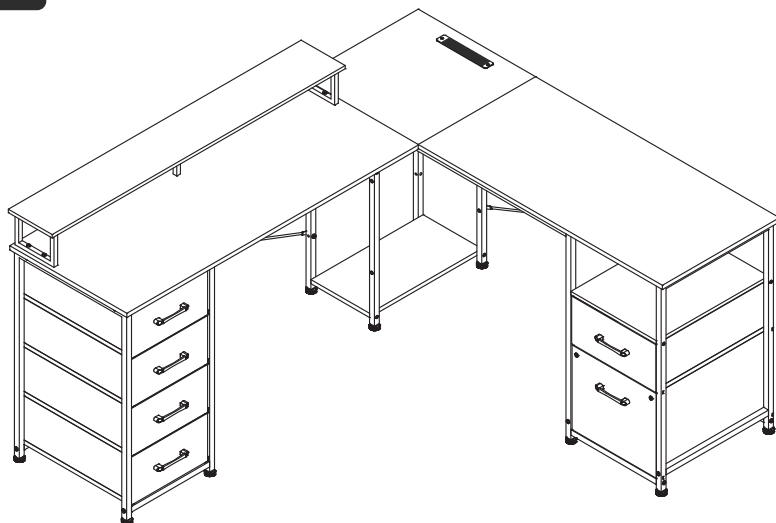

Mode 2: 15-28

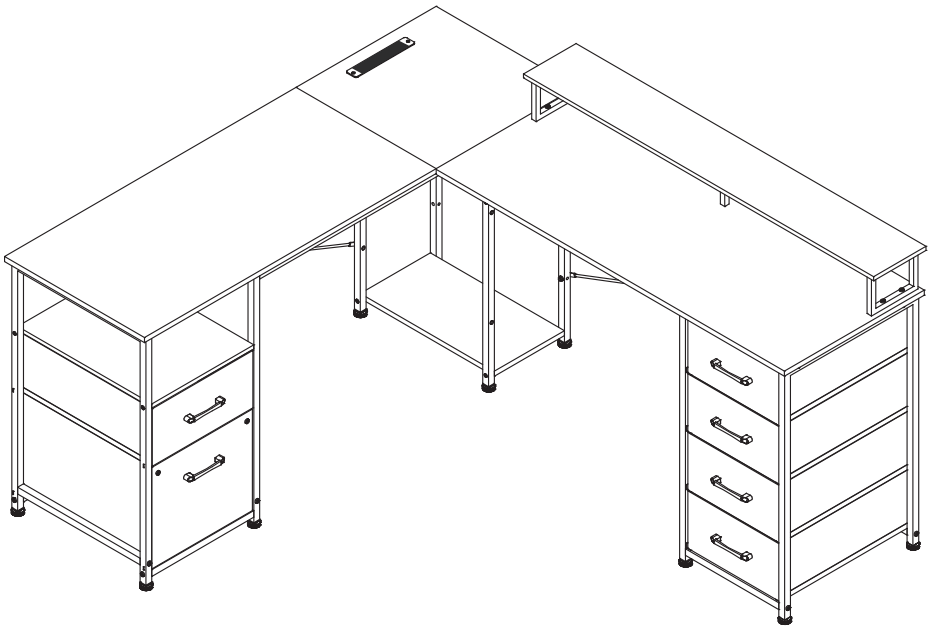

Assembly Instructions

15

Install foot pads ① on desk legs, use screws ③ to assemble Y and N together.

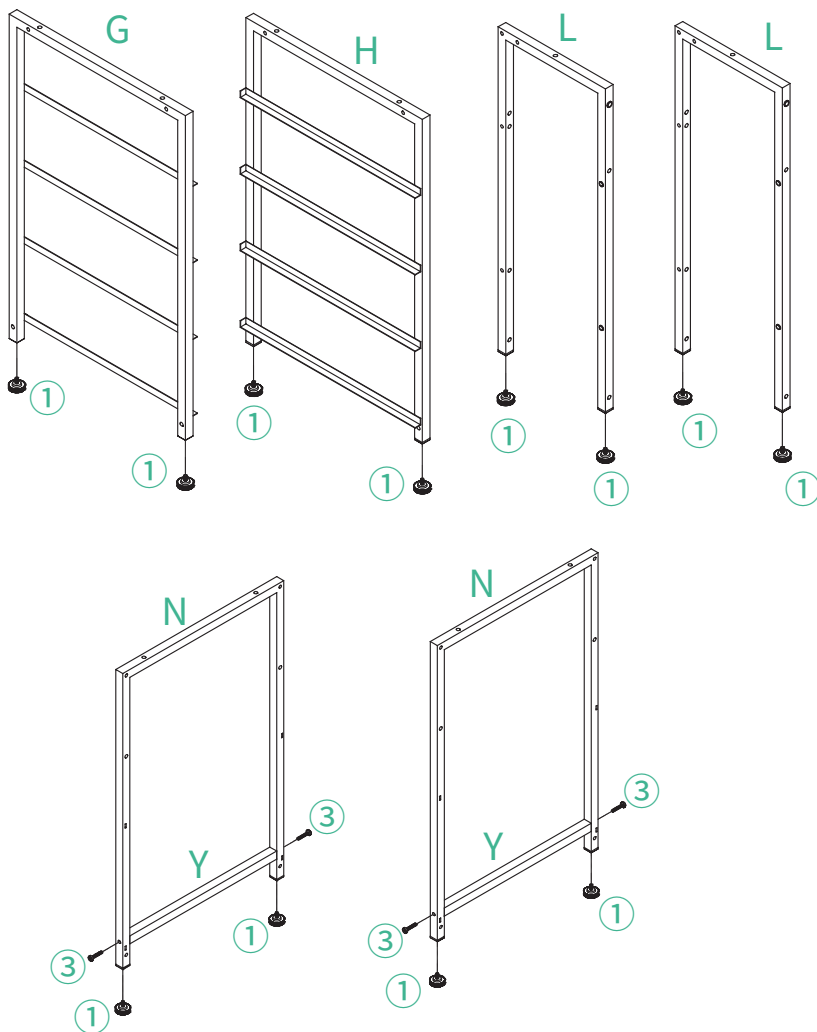

G x1		H x1		L x2		N x2		Y x2		① x12		③ x4		④ x1	
---------	--	---------	--	---------	--	---------	--	---------	--	----------	--	---------	--	---------	--

Assembly Instructions

16

Determine the installation direction according to the arrow indication. Wrong installation direction will cause installation failure in subsequent steps.

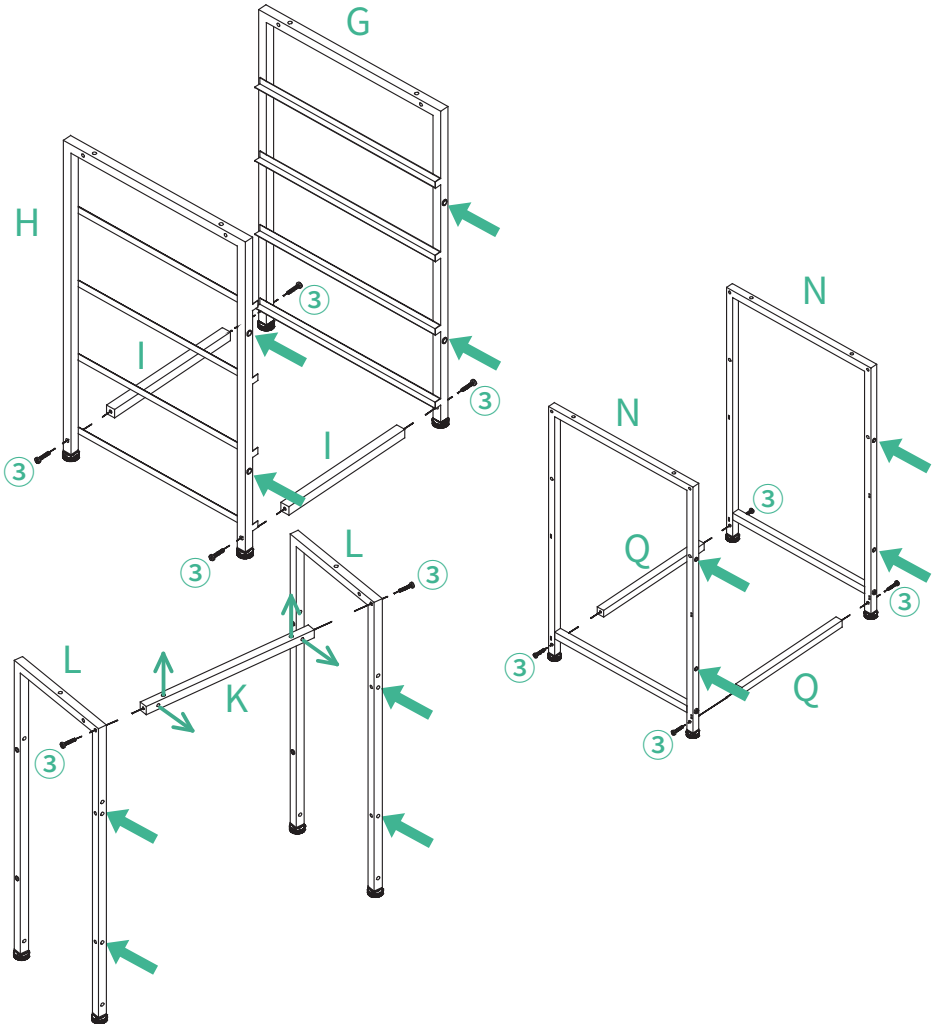

I		Q		K		3	
x2		x2		x1		x10	

Assembly Instructions

17

Determine the installation direction according to the arrow indication. Screw holes marked by arrows are for supporting bars installation and make sure these holes face the same direction.

M

x2



2

x2



3

x2

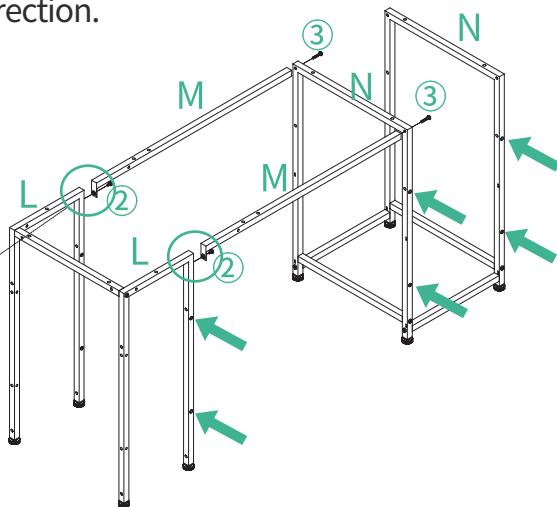
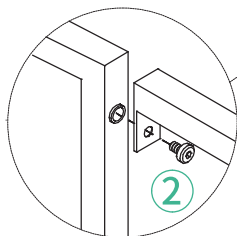

18

Determine the installation direction according to the arrow indication. Screw holes marked by arrows are for supporting bars installation and make sure these holes face the same direction. Determine the installation direction of J as the picture shows.

J

x2



3

x4

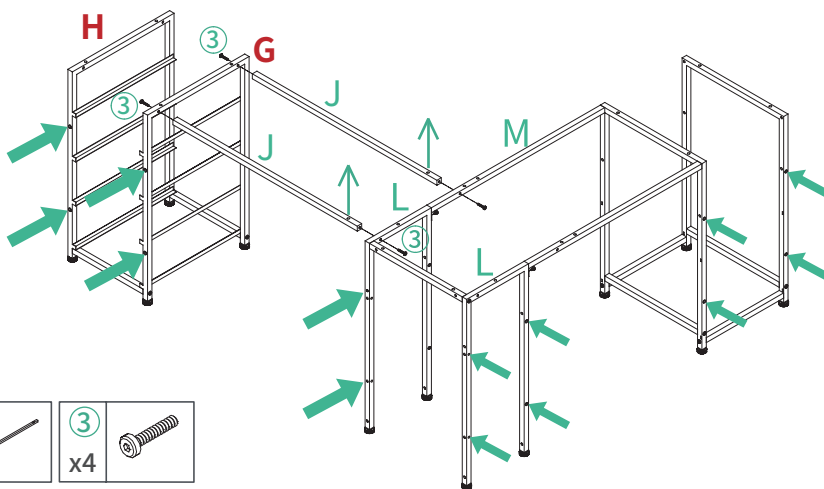

Assembly Instructions

19

Use screws ② & screws ③ & nuts ⑫ to install U and T.

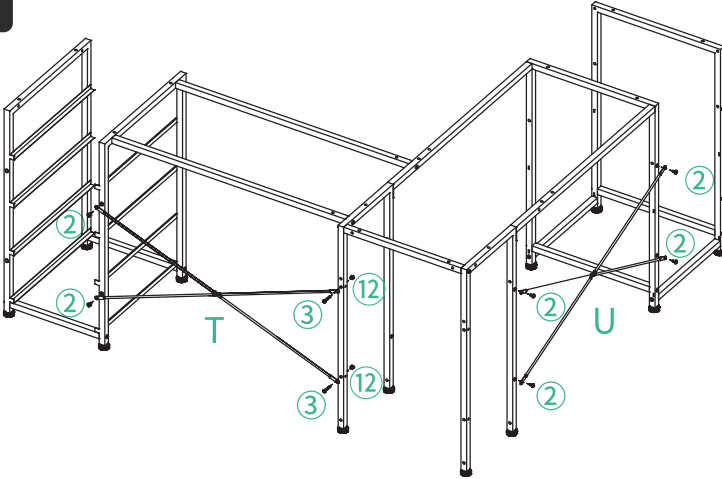

20

Install E on N, install F on L.

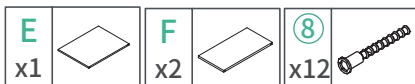
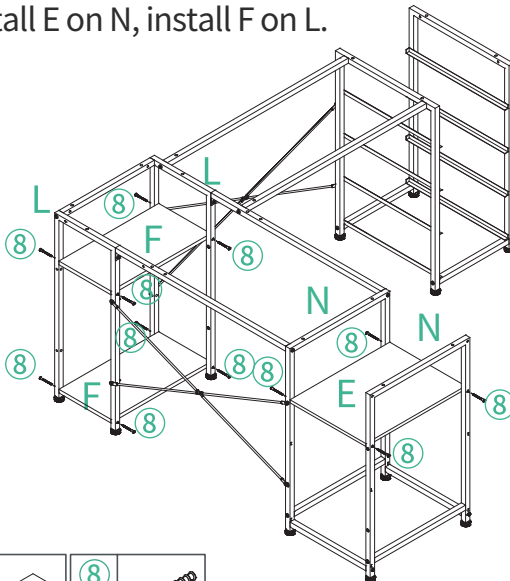

Assembly Instructions

21

Note that board A, C, D must be placed as the picture shows. Insert all the screws into the holes first and make sure boards are aligned, then tighten the screws.

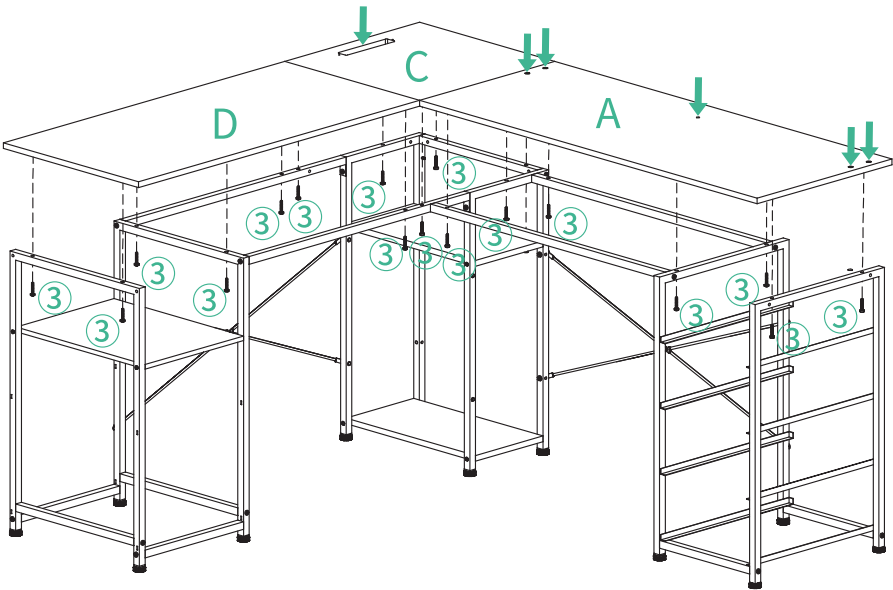

Assembly Instructions

22

Attach the 3M sticker to the light strip, make sure place it on the back of the LED lights.

Use screws ② to install S, use screws ⑤ to install R.

Please note to use right screws, and wrong screws may crack the board.

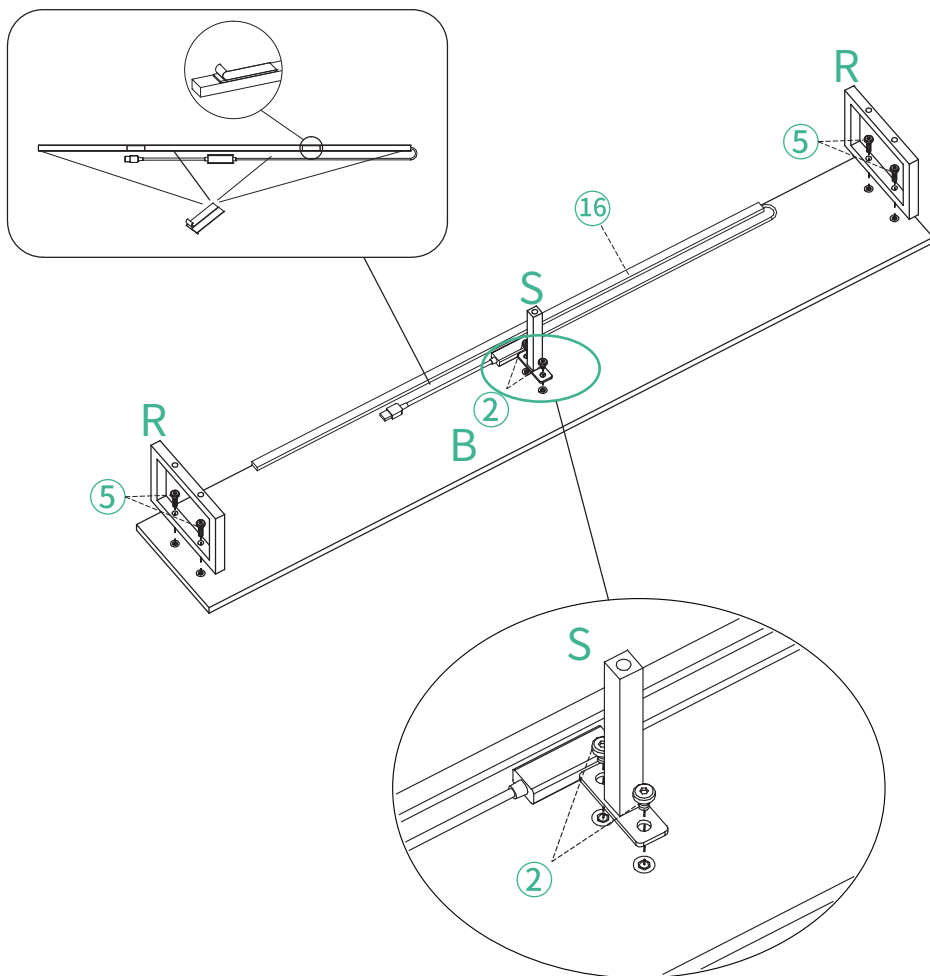

Assembly Instructions

23

Use screws ③ to install S, use screws ⑤ to install monitor shelf, and use screws ⑦ to install ⑩.

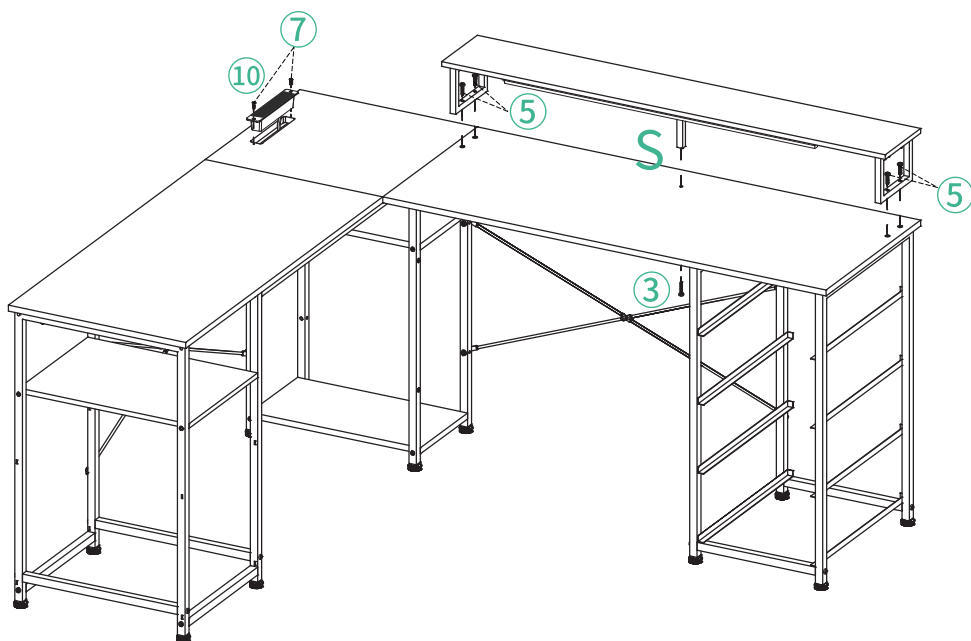

③



x1

⑤



x4

⑦



x2

⑩



x1

Assembly Instructions

24

Insert drawer rails into the rectangular holes on desk legs as the picture shows.

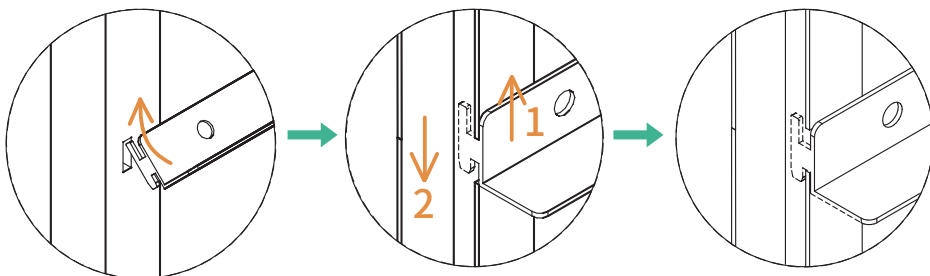
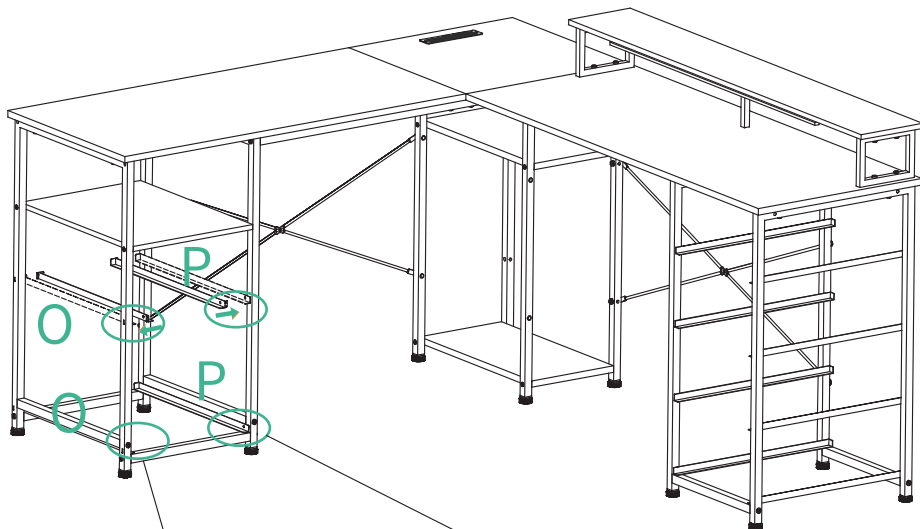

Assembly Instructions

25

Open the drawers and put bottom boards into drawers, then use screws ⑥ to install drawer handles.

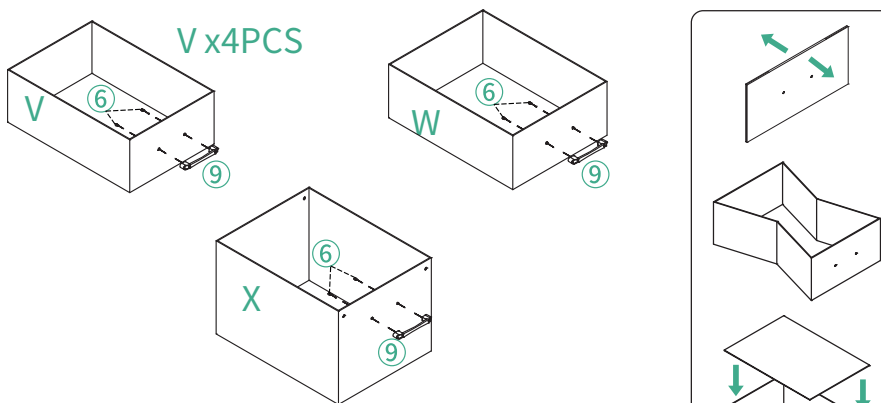

26

Use screws ② and nuts ⑫ to install ⑬ on the drawer, then put part ⑭ in part ⑬.

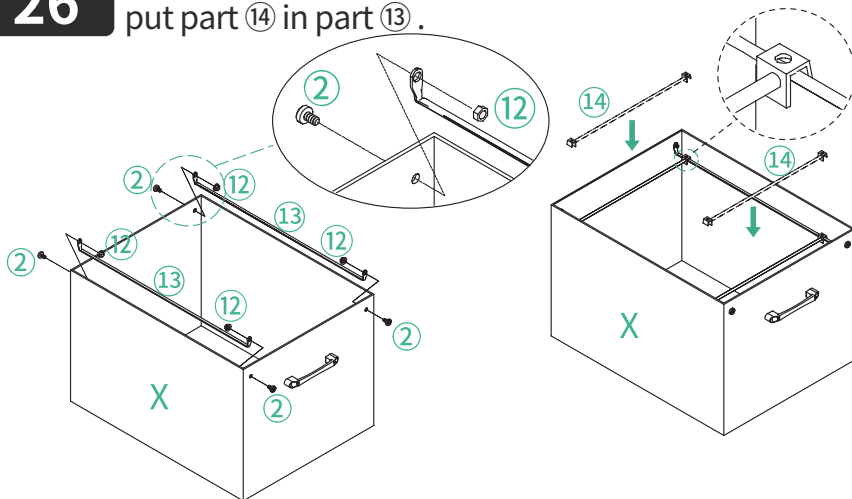

Assembly Instructions

27

Put all drawers in place as the picture shows.

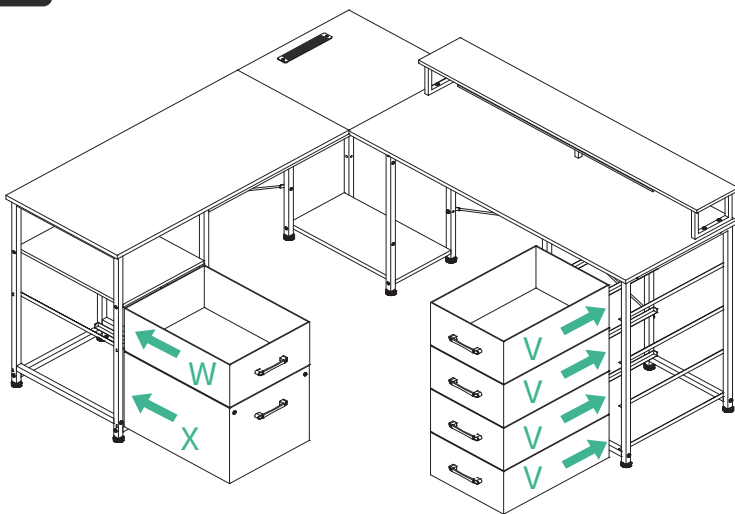

28

Congratulations! You have finished installing the desk.

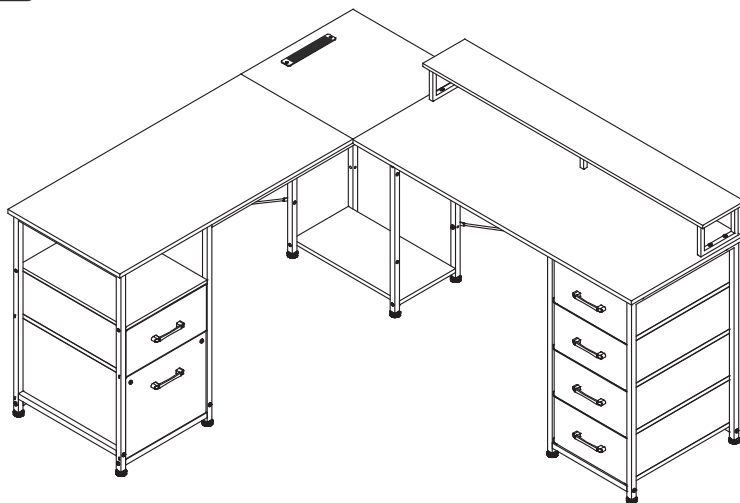

Mode 3: 29-41

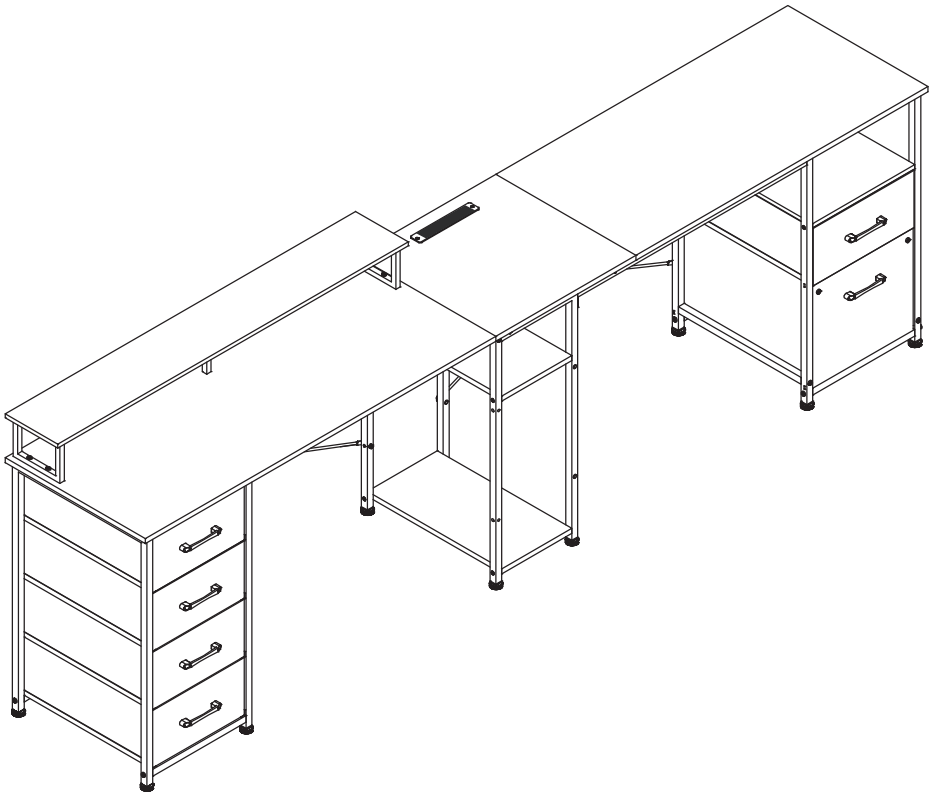

Assembly Instructions

29

Install foot pads ① on desk legs, use screws ③ to assemble Y and N together.

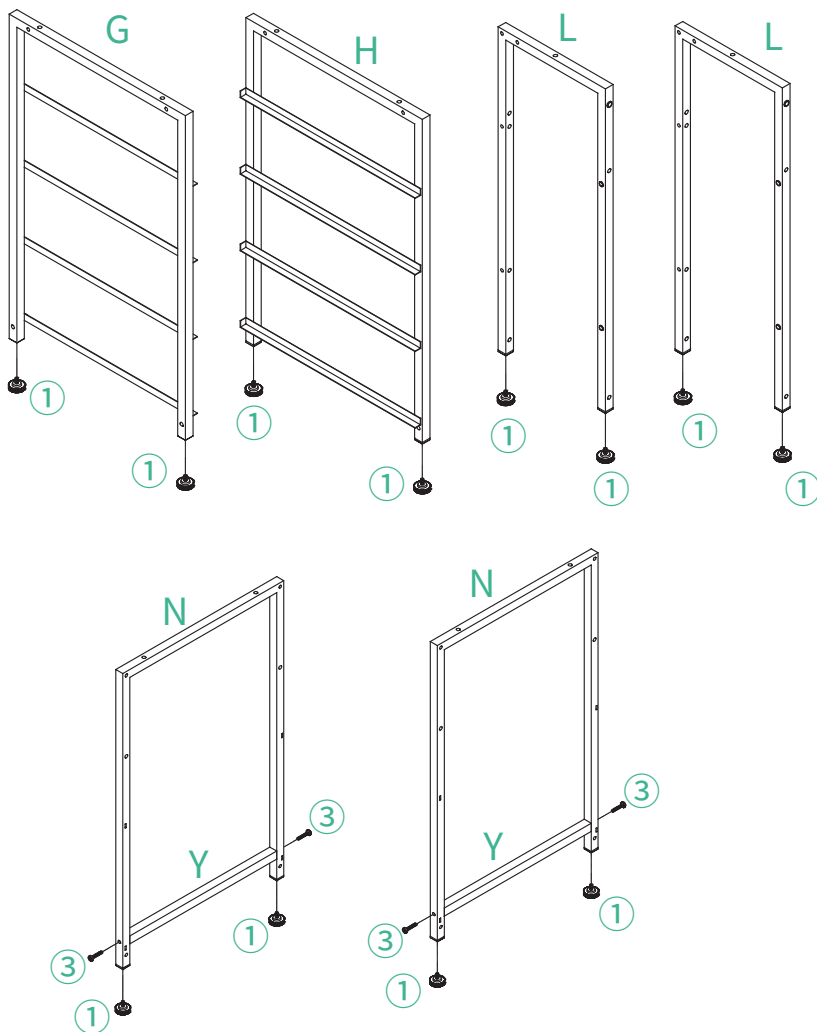





G x1		H x1		L x2		N x2		Y x2		① x12		③ x4	
												④ x1	

Assembly Instructions

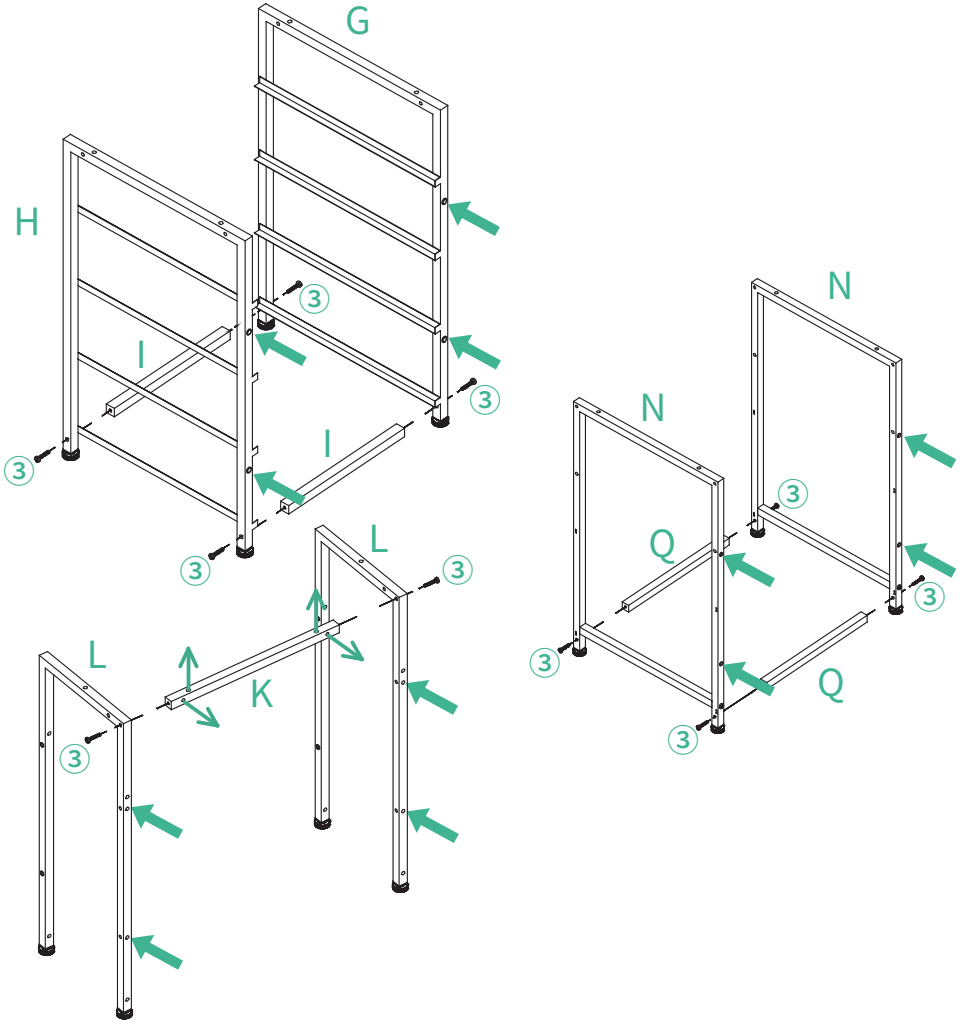
30

Determine the installation direction according to the arrow indication. Wrong installation direction will cause installation failure in subsequent steps.



I x2		Q x2		K x1		3 x10	
---------	---	---------	---	---------	---	----------	---

Assembly Instructions

31

Determine the installation direction according to the arrow indication. Screw holes marked by arrows are for supporting bars installation and make sure these holes face the same direction.

Determine the installation direction of J as the picture shows.

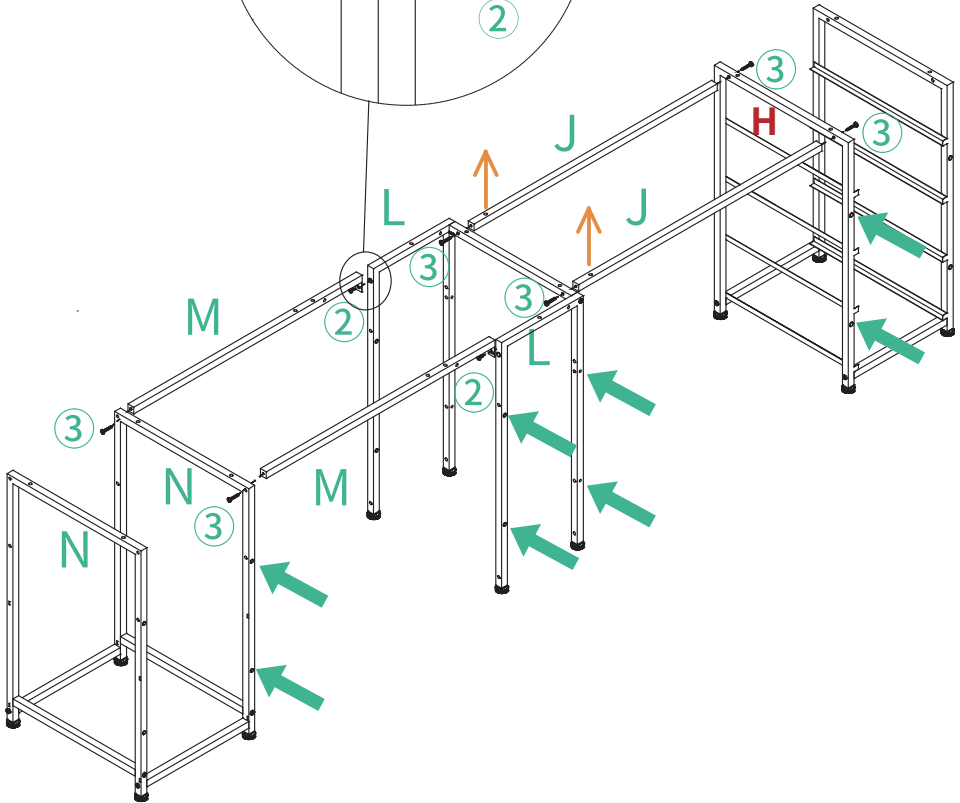
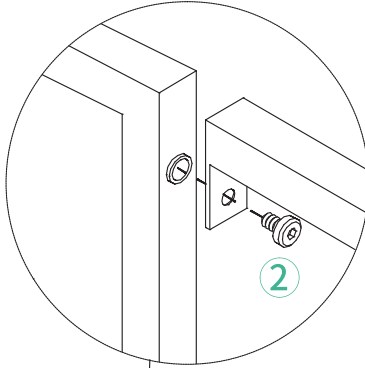
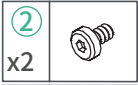
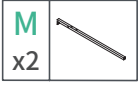

Assembly Instructions

32

Use screws ② & screws ③ & nuts ⑫ to install U and T.

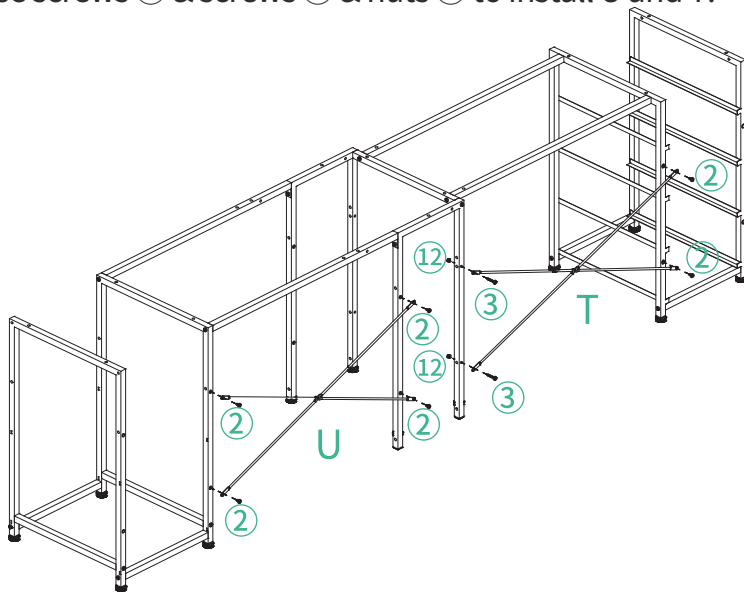
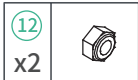
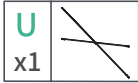

33

Install E on N, install F on L.

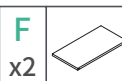
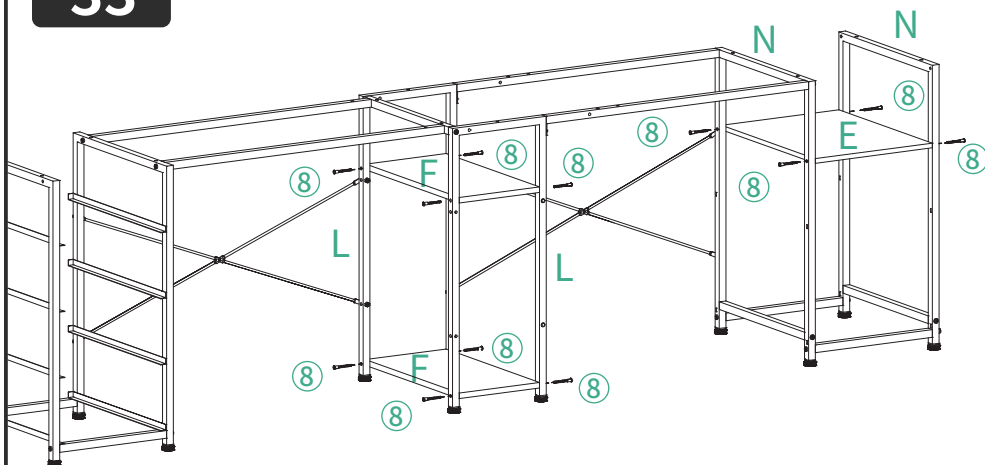

Assembly Instructions

34

Note that board A, C, D must be placed as the picture shows. Insert all the screws into the holes first and make sure boards are aligned, then tighten the screws.

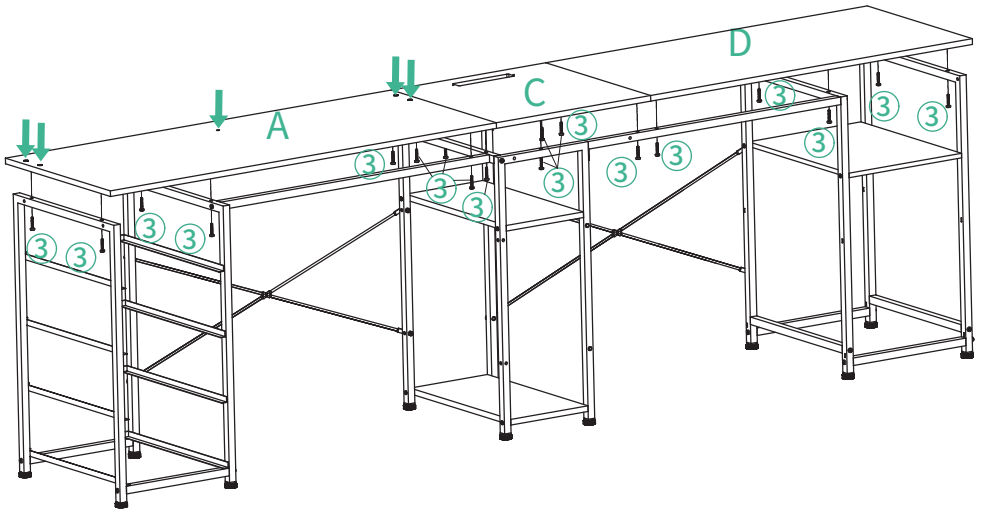

Assembly Instructions

35

Attach the 3M sticker to the light strip, make sure place it on the back of the LED lights.

Use screws ② to install S, use screws ⑤ to install R.

Please note to use right screws, and wrong screws may crack the board.

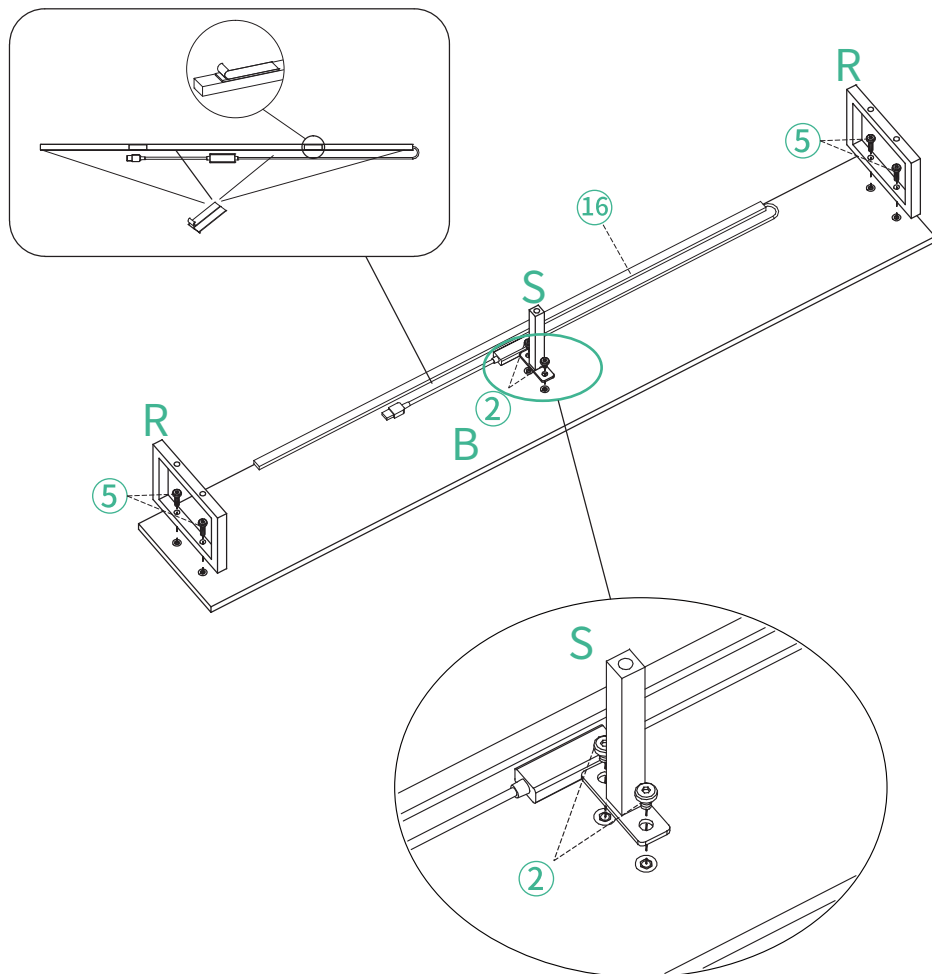

Assembly Instructions

36

Use screws ③ to install S, use screws ⑤ to install monitor shelf, and use screws ⑦ to install ⑩.

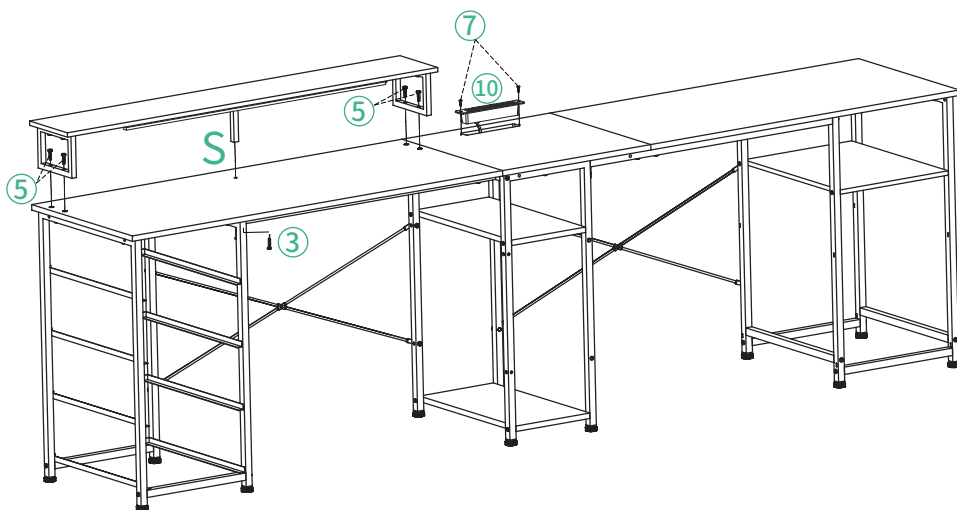

Assembly Instructions

37

Insert drawer rails into the rectangular holes on desk legs as the picture shows.

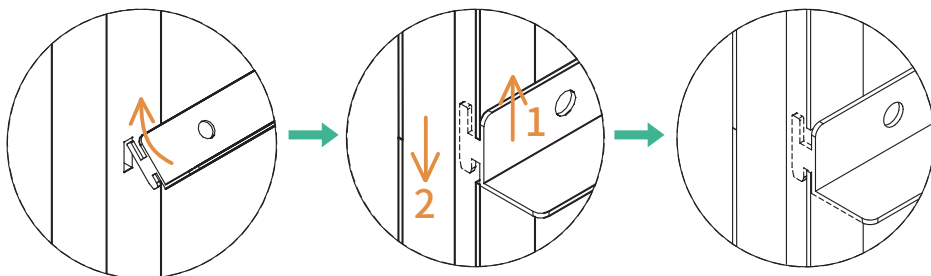
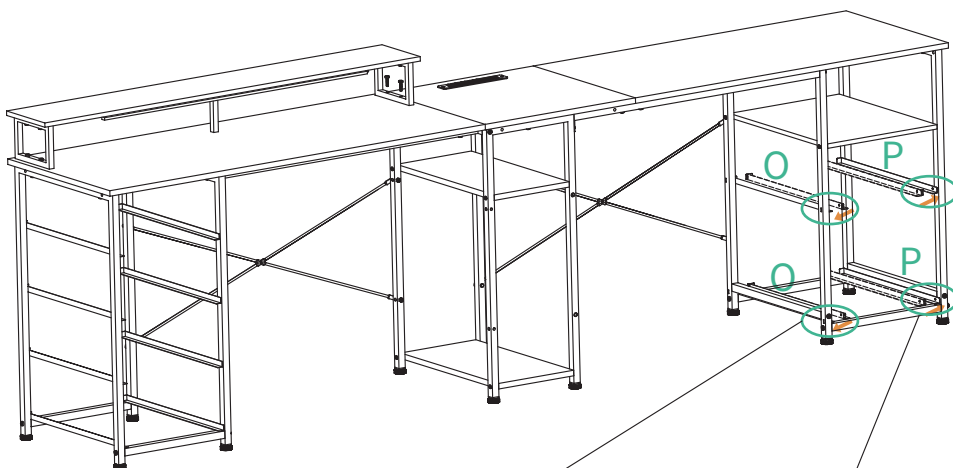

Assembly Instructions

40

Put all drawers in place as the picture shows.

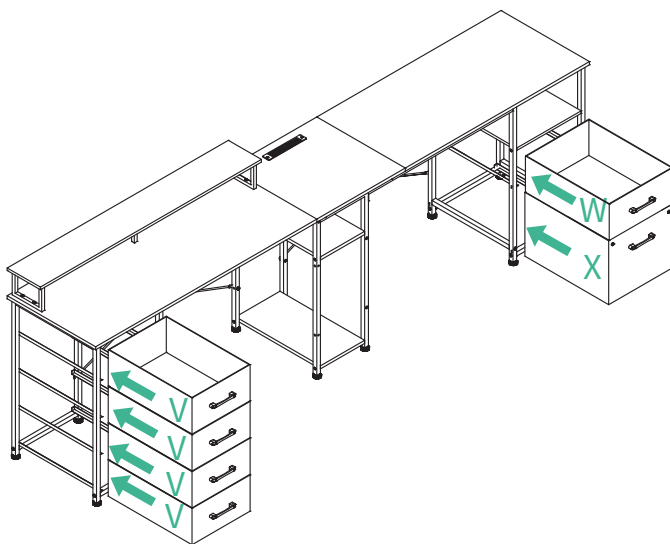

41

Congratulations! You have finished installing the desk.

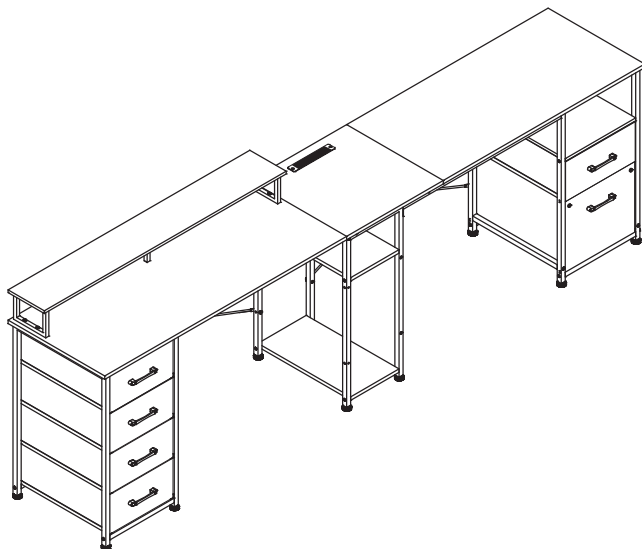

Mode 4: 42-54

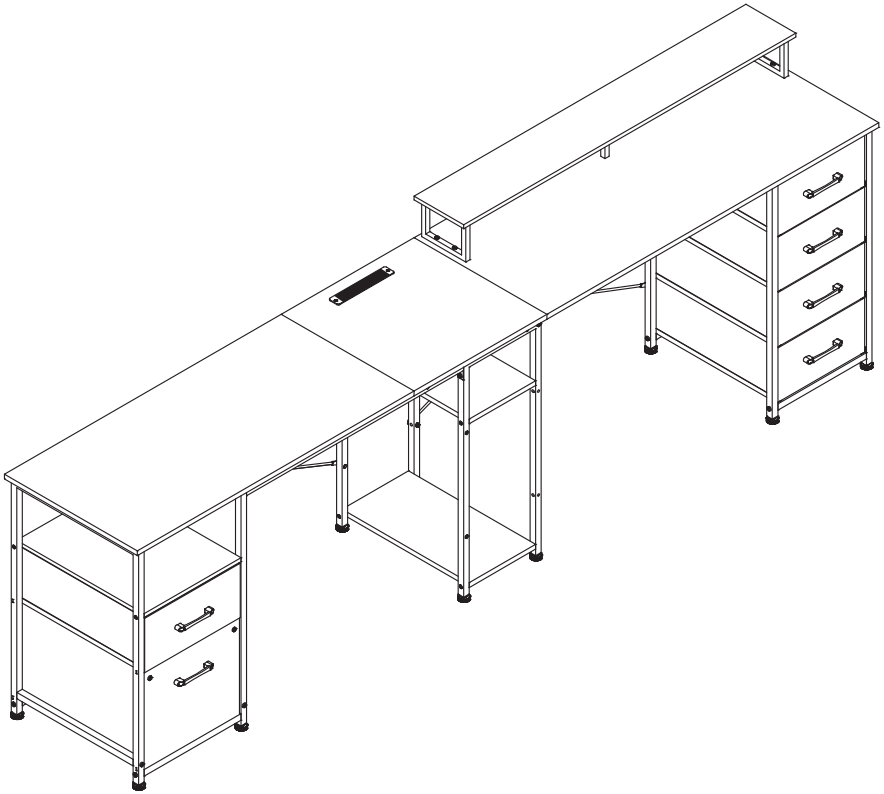

Assembly Instructions

42 Install foot pads ① on desk legs, use screws ③ to assemble Y and N together.

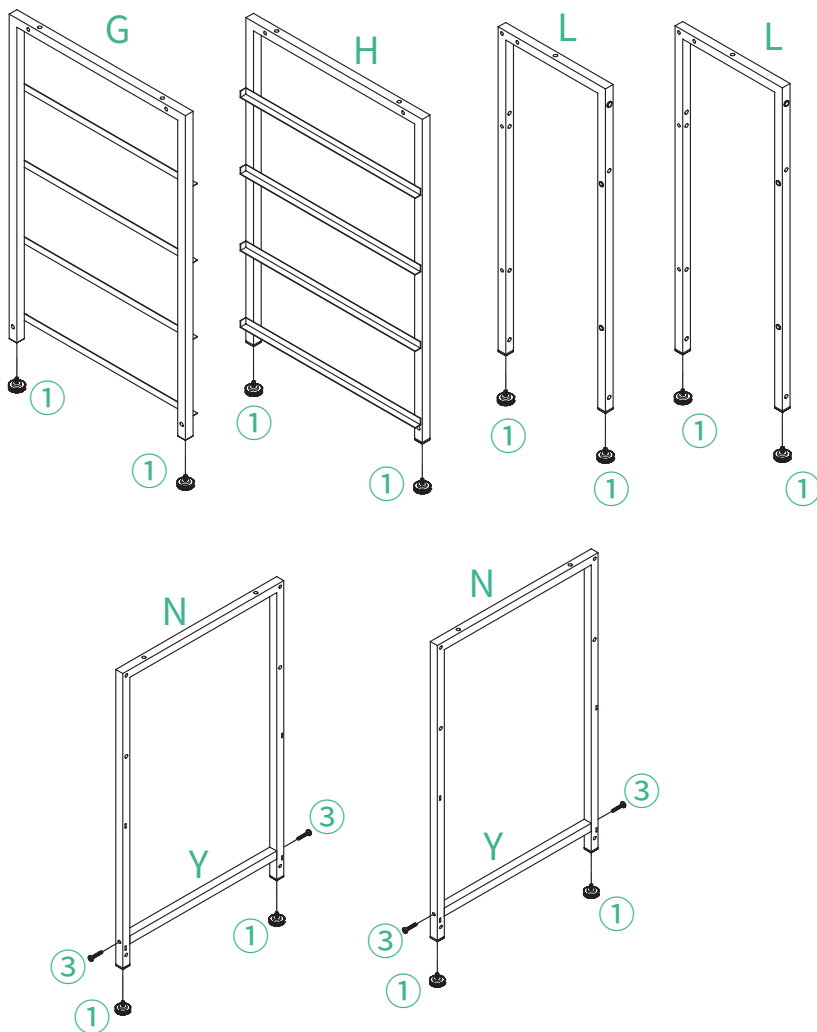



G x1		H x1		L x2		N x2		Y x2		① x12		③ x4	
												④ x1	

Assembly Instructions

43

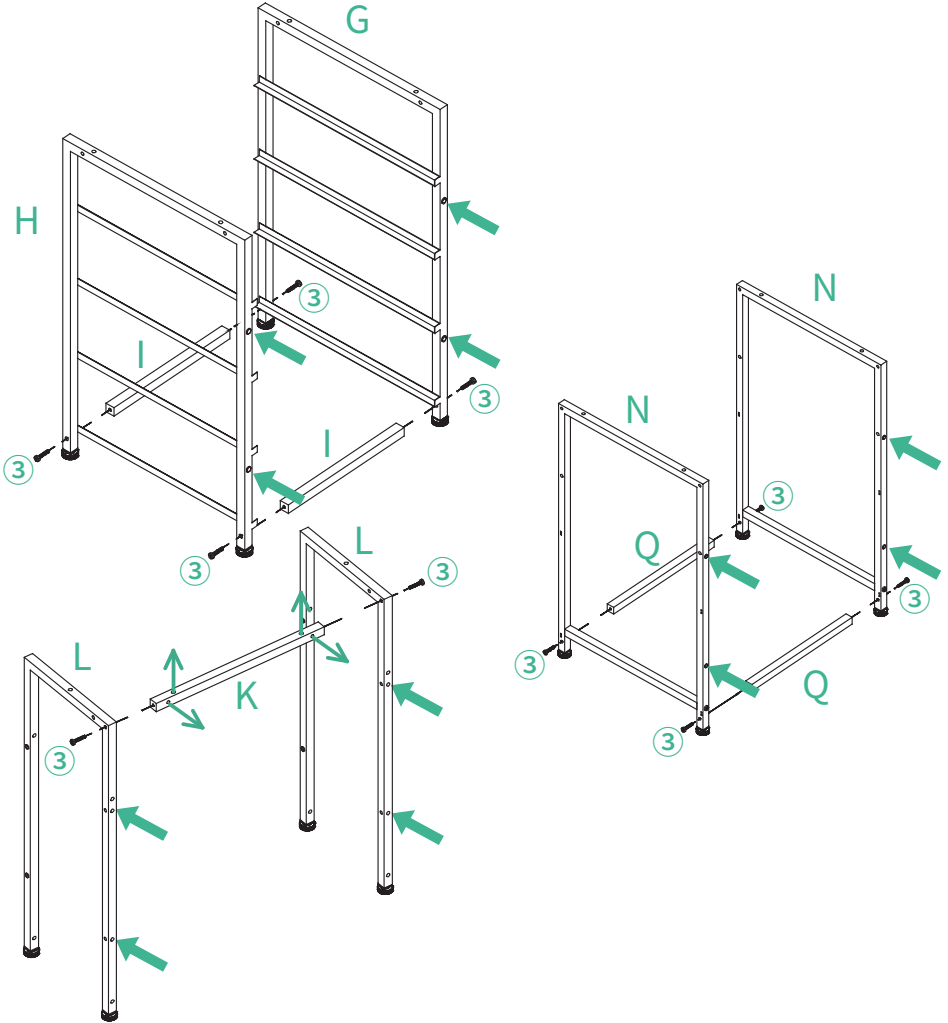
Determine the installation direction according to the arrow indication. Wrong installation direction will cause installation failure in subsequent steps.



I x2		Q x2		K x1		3 x10	
---------	---	---------	---	---------	---	----------	---

Assembly Instructions

44

Determine the installation direction according to the arrow indication. Screw holes marked by arrows are for supporting bars installation and make sure these holes face the same direction. Determine the installation direction of J as the picture shows.

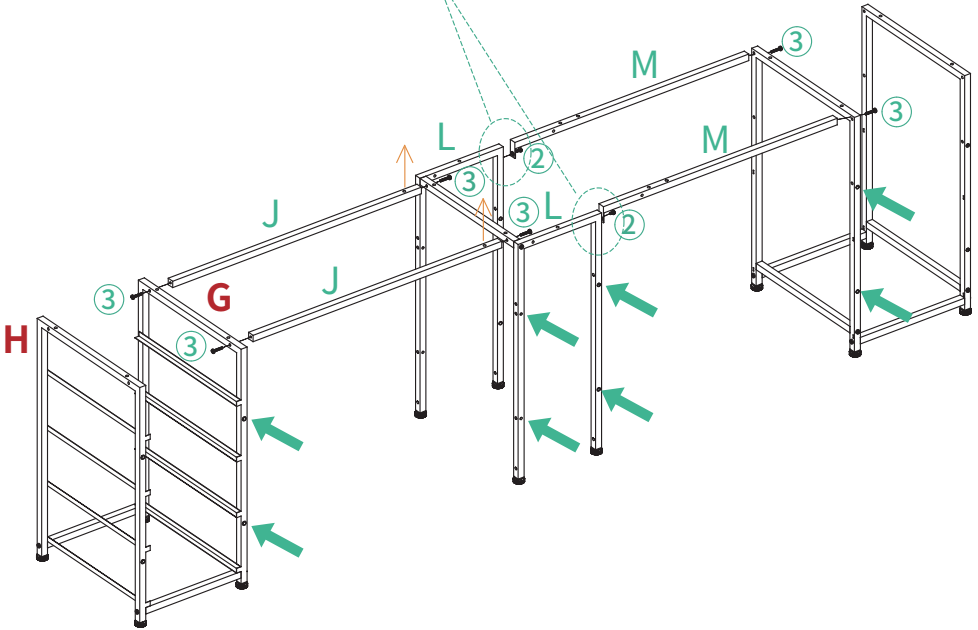
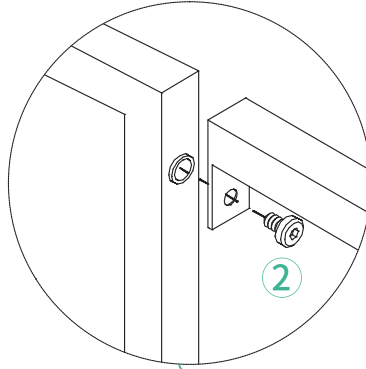
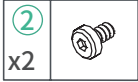
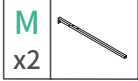

Assembly Instructions

45

Use screws ② & screws ③ & nuts ⑫ to install U and T.

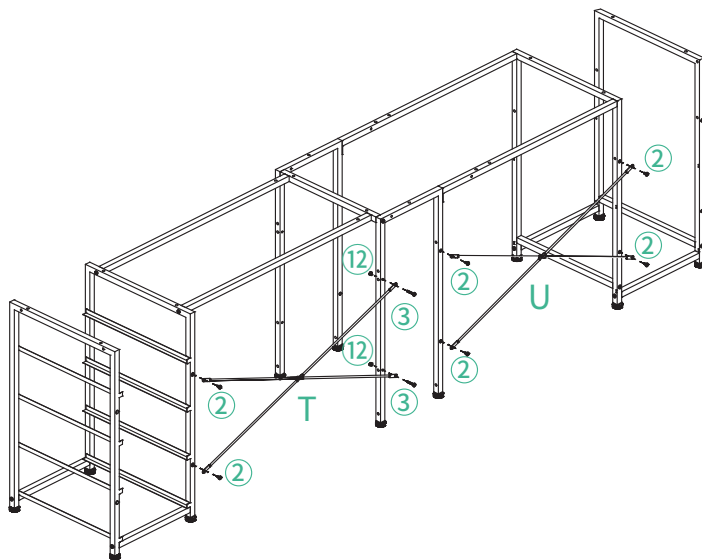
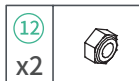

46

Install E on N, install F on L.

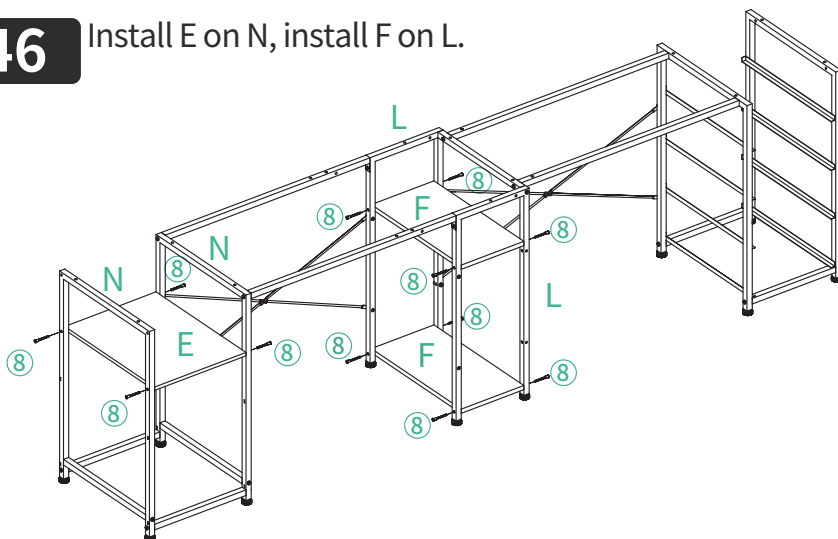

Assembly Instructions

47

Note that board A, C, D must be placed as the picture shows. Insert all the screws into the holes first and make sure boards are aligned, then tighten the screws.

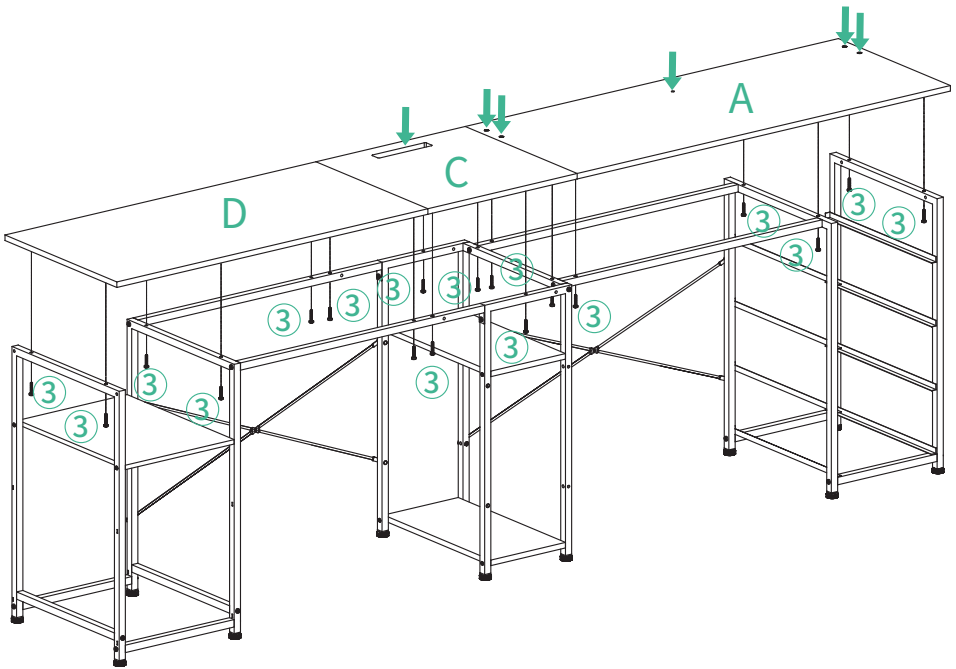

Assembly Instructions

48

Attach the 3M sticker to the light strip, make sure place it on the back of the LED lights.

Use screws ② to install S, use screws ⑤ to install R.

Please note to use right screws, and wrong screws may crack the board.

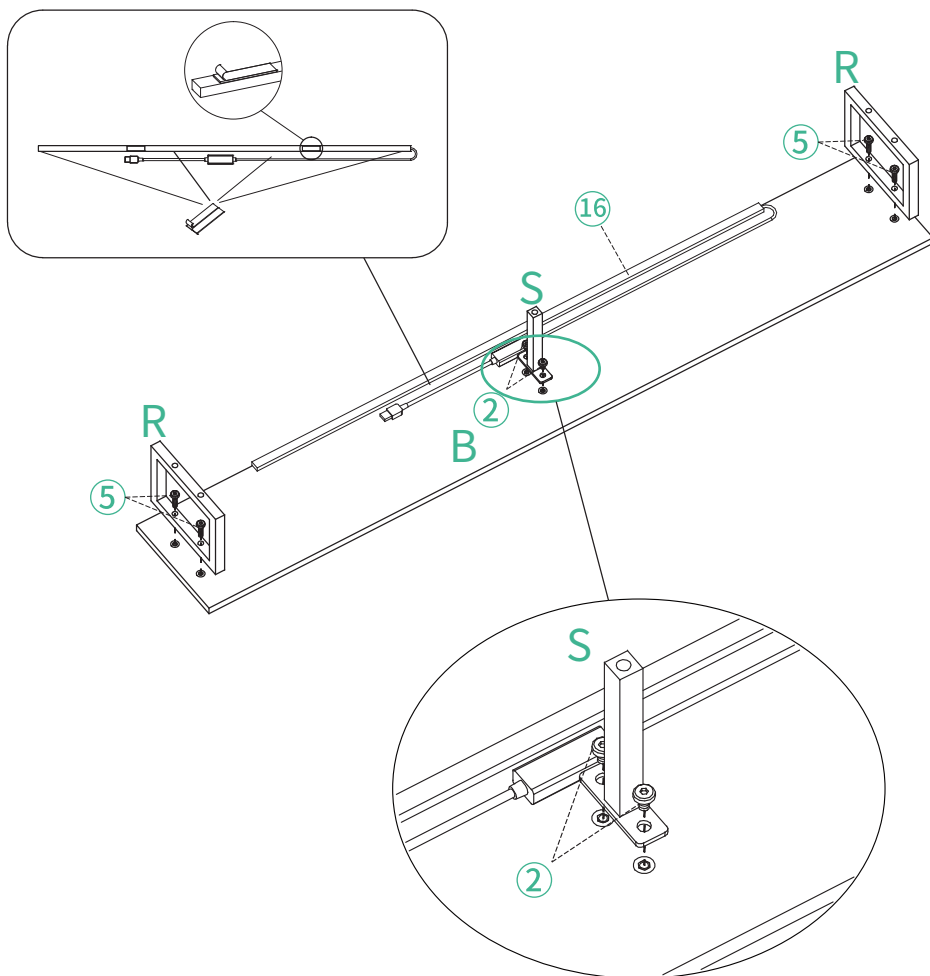

Assembly Instructions

49

Use screws ③ to install S, use screws ⑤ to install monitor shelf, and use screws ⑦ to install ⑩.

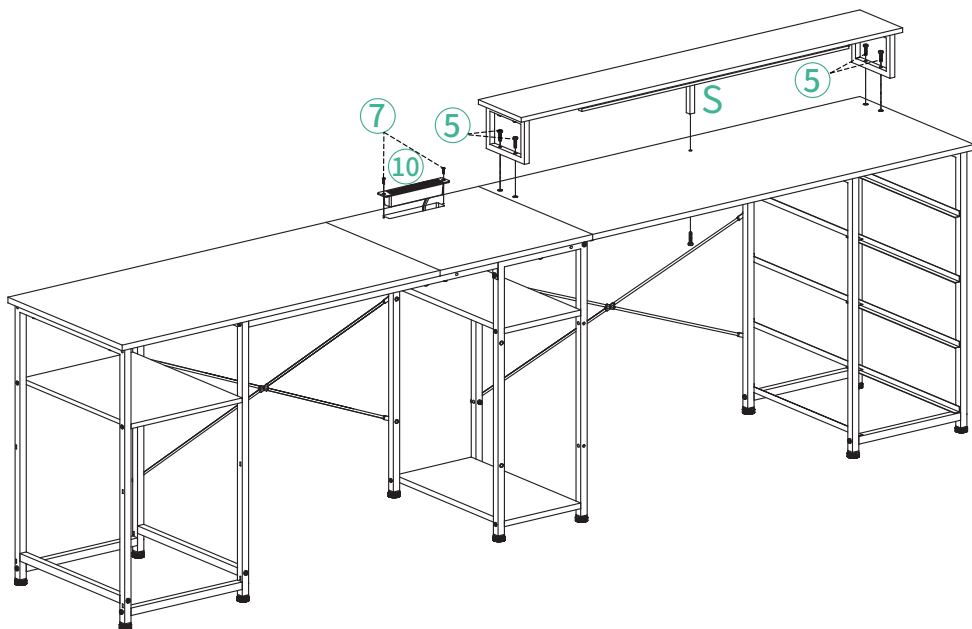

③



x1

⑤



x4

⑦



x2

⑩



x1

Assembly Instructions

50

Insert drawer rails into the rectangular holes on desk legs as the picture shows.

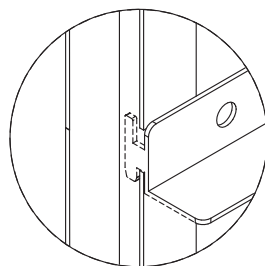
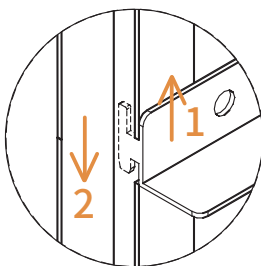
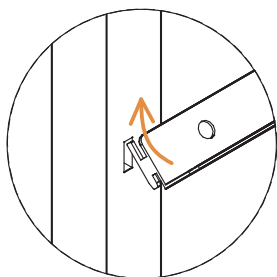
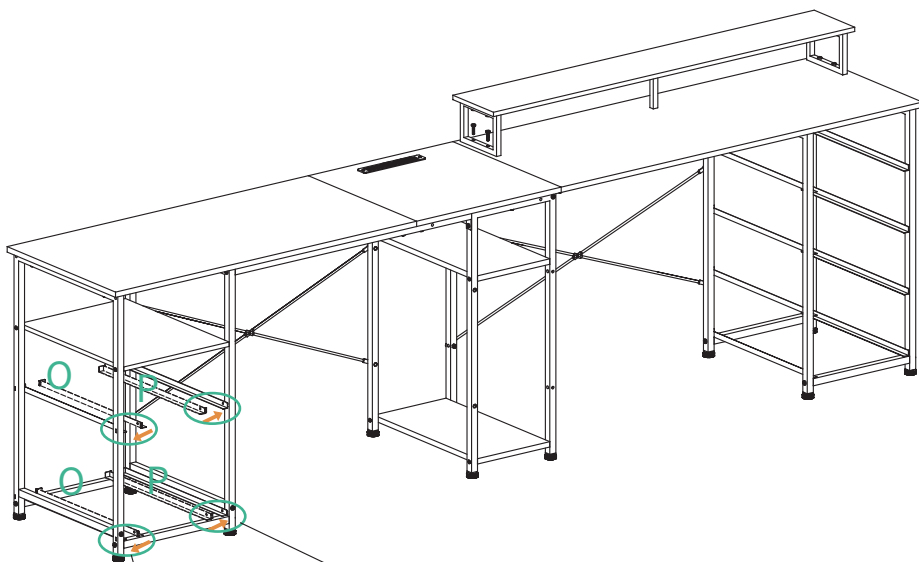

Assembly Instructions

51

Open the drawers and put bottom boards into drawers, then use screws ⑥ to install drawer handles.

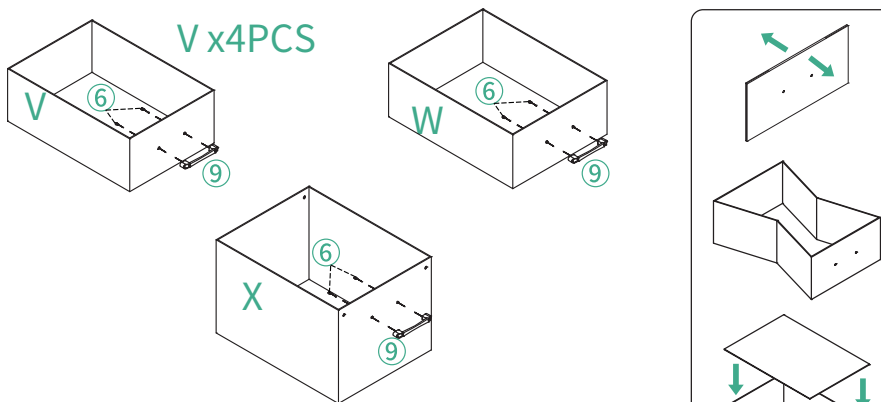

52

Use screws ② and nuts ⑫ to install ⑬ on the drawer, then put part ⑭ in part ⑬.

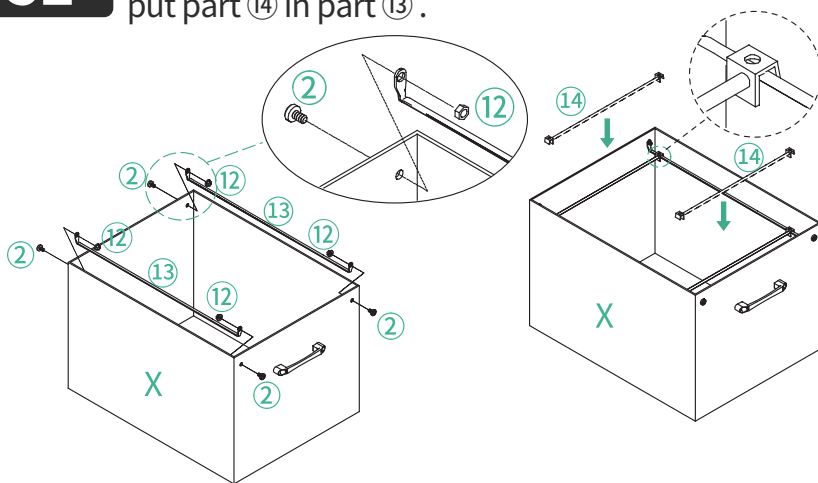

53

Put all drawers in place as the picture shows.

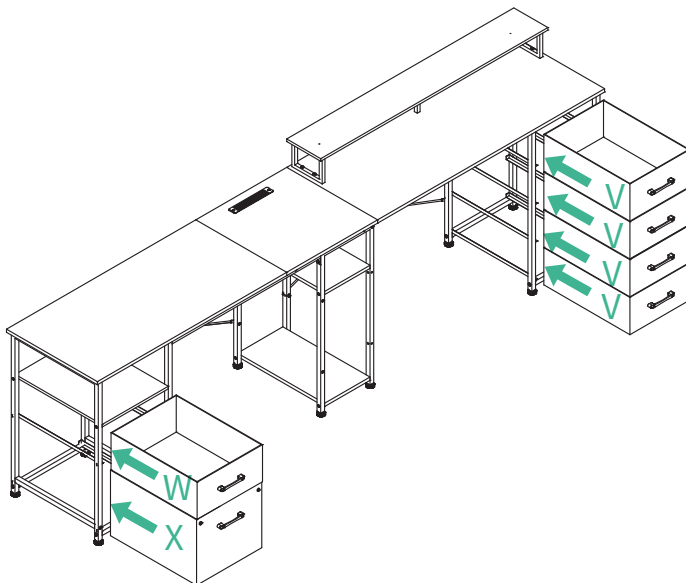

54

Congratulations! You have finished installing the desk.

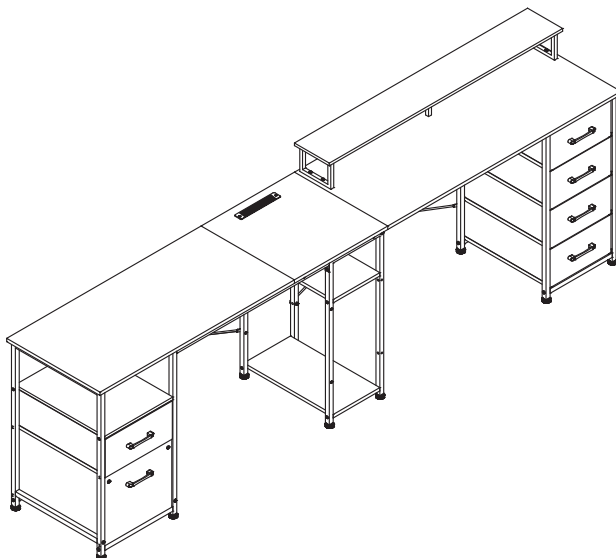

Customer Service



30 DAY Return Policy

If you're not completely satisfied with your purchase, please return the merchandise via our Official Customer Support. Unused merchandise can be refunded or exchanged within 30 days of purchase.



1-Year Warranty

We guarantee your product is free from defects in product material and workmanship for one (1) year starting from the date of purchase during normal use of household conditions. If your appliance fails to operate properly within our warranty period, we will arrange a new one. Replacement is free and all shipping costs are covered.



Quick Response within 24 Hours

If you are still unable to resolve the issue you are experiencing, please contact us immediately via our support email. It doesn't matter if the product has been installed or not, our customer support team will respond within 24 hours and assist you quickly and efficiently. The most efficient way to confirm your problem to us is to attach a video, which illustrates your product issues.

Kundendienst



30- Tag Rückgaberecht

Wenn Sie mit Ihrem Kauf nicht ganz zufrieden sind, schicken Sie die Ware einfach über unseren offiziellen Kundensupport zurück. Unbenutzte Artikel können innerhalb von 30 Tagen ab dem ursprünglichen Kaufdatum erstattet oder umgetauscht werden.



1- Jahr Garantie

Wir garantieren, dass Ihr Produkt ab dem Kaufdatum ein (1) Jahr lang bei dem normalen Gebrauch im Haushalt keine Material- und Verarbeitungsfehlern hat. Wenn Ihr Gerät innerhalb unserer Garantiezeit nicht richtig funktioniert, veranlassen wir einen kostenlosen Ersatz und übernehmen alle Versandkosten.



Schnelle Antwort innerhalb von 24 Stunden

Wenn Sie das auftretende Problem immer noch nicht lösen können, nehmen Sie bitte umgehend Kontakt auf über unsere Support-E-Mail. Das macht nichts wenn das Produkt schon installiert geworden ist. Unser Kundensupport-Team antwortet innerhalb von 24 Stunden und hilft Ihnen schnell und effizient. Damit wir Ihr Problem möglichst schnell und effizient feststellen, hängen Sie bitte ein Video an, das Ihr Produktproblem veranschaulicht.

Service client



Politique de retour de 30 jours

Si vous n'êtes pas entièrement satisfait de votre achat, il vous suffit de renvoyer la marchandise via notre Service clientèle officiel. La marchandise non utilisée peut être remboursée ou échangée pendant 30 jours à partir de la date de l'achat.



Garantie de 1 an

Nous garantissons que votre produit est sans défaut de matériau et de fabrication pendant 1 an à compter de la date d'achat dans les conditions normales d'utilisation régulière. Si votre appareil ne fonctionne pas normalement pendant la période de garantie, nous remplacerons gratuitement et couvrirons tous les frais d'expédition.



Réponse rapide dans les 24 heures

Si vous n'arrivez pas à résoudre le problème que vous rencontrez, veuillez nous contacter immédiatement par notre courriel d'assistance. Peu importe si le produit a été installé, notre équipe de soutien à la clientèle vous répondra dans les 24 heures et vous aidera rapidement et efficacement. Le moyen le plus efficace de confirmer votre problème est de nous contacter en joignant une vidéo illustrant le problème de votre produit.

Servicio al Cliente



Políticas de Devoluciones de 30 días

Si no se satisface completamente su compra, simplemente devuelve la mercancía por vía de nuestro Servicio de Asistencia al Cliente. La mercancía no utilizada se puede reembolsar o cambiar dentro de 30 días a partir de la fecha original de compra.



Garantía de 1 Año

Le garantizamos el producto contra defectos de materiales y mano de obra en condiciones normales de uso doméstico durante un (1) año a partir de la fecha de compra. Si su aparato no funciona correctamente en el periodo de garantía, realizaremos un cambio gratuito y los gastos de envío serán a nuestro cargo.



Rápida respuesta en 24 Horas

Si todavía no puede resolver el problema que tiene, contáctenos inmediatamente por nuestro correo electrónico. No importa si el producto ha sido instalado o no, nuestro equipo de servicio al cliente le responderá en 24 horas para ayudarle rápidamente y eficientemente. La forma más eficaz es adjuntar un vídeo demostrando el problema del producto.



Politica di restituzione entro 30 giorni

Se non sei completamente soddisfatto del tuo acquisto, restituisci semplicemente la merce tramite il nostro supporto clienti ufficiale. La merce non utilizzata può essere rimborsata o cambiata entro 30 giorni dalla data di acquisto originale.



1 anno di garanzia

Garantiamo che il prodotto è esente da difetti di materiale e lavorazione per un (1) anno a partire dalla data di acquisto durante il normale utilizzo delle condizioni domestiche. Se il tuo apparecchio non funziona correttamente entro il nostro periodo di garanzia, organizzeremo una nuovasostituzione gratuita e copriremo tutte le spese di spedizione.



Risposta rapida entro 24 ore

Se ancora non riesci a risolvere il problema che stai riscontrando, contattaci immediatamente alla nostra email di supporto. Non importa se il prodotto è stato installato, il nostro team di assistenza clienti risponderà entro 24 ore e ti assisterà in modo rapido ed efficiente. Il modo più efficiente per confermarci il tuo problema è allegare un video che illustri il problema del prodotto.

Problems You May Encounter

PART	PROBLEM	SOLUTION
Whole Product	Parts are missing, defective or having wrong parts in package.	You can contact us and we will get back to you within 24 hours. Or, you can reach us via after-sales email.
	Having issue(s) while reading the instruction or completing the assembly.	You can contact us and we will get back to you within 24 hours. Or, you can reach us via after-sales email.
	Encountering non-human caused damage during usage.	If the product is damaged due to non-human causes, please keep the product and send us photos of it. We will ascertain the cause of the product damage within 48 hours and provide you with a satisfactory solution.
Table Surface	Board Surface is broken, scratched or lack of somescrew holes.	You can contact us and we will get back to you within 24 hours. Or, you can reach us via after-sales email.
	The screw holes that on the board and the steel frame don't line up.	<ol style="list-style-type: none"> 1. Please tighten the screws on the board by 70%, do not tighten completely. 2. Adjusting board and steel frame until the screw holes are lined up, then tighten all the screws.
	The desk board is uneven or not tight that has gaps after being assembled.	<ol style="list-style-type: none"> 1. Loosen the screws in the uneven or gap positions; adjust until the desktops are flat and tight, and then tighten the screws. 2. If your problem still can't be solved, please feel free to contact us.
Steel Frame	The steel frame is bent, broken, painted, rusted or damaged.	You can contact us and we will get back to you within 24 hours. Or, you can reach us via after-sales email.
	The table is unstable after being assembled.	<ol style="list-style-type: none"> 1. Check if the screws are tightened. 2. Read throughout the manual, check are there any parts installed incorrectly or missing assembled. 3. If your problem still can't be solved, please feel free to contact us.
	Encountering non-human caused damage during usage.	If the product is damaged due to non-human causes, please keep the product and send us photos of it. We will ascertain the cause of the product damage within 48 hours and provide you with a satisfactory solution.

Probleme, auf die Sie stoßen könnten

TEIL	PROBLEM	LÖSUNG
Gesamtes Produkt	Teile fehlen, sind defekt oder es befinden sich falsche Teile in der Verpackung.	Sie können uns kontaktieren und wir werden uns innerhalb von 24 Stunden bei Ihnen melden. Sie können uns auch per E-Mail nach dem Kauf erreichen.
	Probleme beim Lesen der Anleitung oder bei der Fertigstellung der Montage.	Sie können uns kontaktieren und wir werden uns innerhalb von 24 Stunden bei Ihnen melden. Sie können uns auch per E-Mail nach dem Kauf erreichen.
	Nicht von Menschenhand verursachte Schäden während des Gebrauchs.	Wenn das Produkt durch nicht-menschliche Ursachen beschädigt ist, bewahren Sie es bitte auf und schicken Sie uns Fotos davon. Wir werden die Ursache für den Produktschaden innerhalb von 48 Stunden feststellen und Ihnen eine zufriedenstellende Lösung anbieten.
Tischoberfläche	Die Oberfläche der Platine ist beschädigt, zerkratzt oder es fehlen einige Schraubenlöcher.	Sie können uns kontaktieren und wir werden uns innerhalb von 24 Stunden bei Ihnen melden. Sie können uns auch per E-Mail nach dem Kauf erreichen.
	Die Schraubenlöcher auf der Platte und dem Stahlrahmen stimmen nicht überein.	<ol style="list-style-type: none"> 1. bitte ziehen Sie die Schrauben auf der Platine mit 70% an, nicht ganz festziehen. 2. Justieren Sie das Brett und den Stahlrahmen, bis die Schraubenlöcher auf einer Linie liegen, dann ziehen Sie alle Schrauben fest.
	Die Tischplatte ist uneben oder nicht dicht und weist nach dem Zusammenbau Lücken auf.	<ol style="list-style-type: none"> 1 Lösen Sie die Schrauben in den unebenen oder lückenhaften Positionen; stellen Sie sie ein, bis die Tischplatten eben und fest sind, und ziehen Sie dann die Schrauben fest. 2. Wenn Sie das Problem nicht lösen können, wenden Sie sich bitte an uns.
Stahlrahmen	Der Stahlrahmen ist verbogen, gebrochen, lackiert, verrostet oder beschädigt.	Sie können uns kontaktieren und wir werden uns innerhalb von 24 Stunden bei Ihnen melden. Sie können uns auch per E-Mail nach dem Kauf erreichen.
	Der Tisch ist nach dem Zusammenbau instabil.	<ol style="list-style-type: none"> 1. prüfen Sie, ob die Schrauben fest angezogen sind 2. Lesen Sie die gesamte Anleitung durch und überprüfen Sie, ob Teile falsch oder gar nicht montiert wurden. 3. Wenn Ihr Problem immer noch nicht gelöst werden kann, kontaktieren Sie uns bitte.
	Nicht von Menschenhand verursachte Schäden während der Benutzung.	Wenn das Produkt durch nicht-menschliche Ursachen beschädigt ist, bewahren Sie es bitte auf und schicken Sie uns Fotos davon. Wir werden die Ursache für den Produktschaden innerhalb von 48 Stunden feststellen und Ihnen eine zufriedenstellende Lösung anbieten.

Les problèmes que vous pouvez rencontrer

PARTIE	PROBLÈME	SOLUTION
Produit entier	Pièces manquantes, défectueuses ou mauvaises dans l'emballage.	Vous pouvez nous contacter et nous vous répondrons dans les 24 heures. Vous pouvez également nous contacter par courrier électronique après-vente.
	Problème(s) lors de la lecture des instructions ou de l'assemblage.	Vous pouvez nous contacter et nous vous répondrons dans les 24 heures. Vous pouvez également nous contacter par courrier électronique après-vente.
	Des dommages non causés par l'homme ont été constatés lors de l'utilisation.	Si le produit est endommagé pour des raisons non humaines, veuillez conserver le produit et nous envoyer des photos. Nous déterminerons la cause de l'endommagement du produit dans les 48 heures et vous fournirons une solution satisfaisante.
Surface de la table	La surface de la carte est cassée, rayée ou dépourvue de trous de vis.	Vous pouvez nous contacter et nous vous répondrons dans les 24 heures. Vous pouvez également nous contacter par courrier électronique après-vente.
	Les trous de vis du plateau et du cadre en acier ne sont pas alignés.	<ol style="list-style-type: none"> 1. serrer les vis de la carte à 70%, ne pas serrer complètement. 2. Ajustez la planche et le cadre en acier jusqu'à ce que les trous de vis soient alignés, puis serrez toutes les vis.
	Le plateau du bureau est inégal ou mal serré et présente des lacunes après l'assemblage.	<ol style="list-style-type: none"> 1. Desserrer les vis dans les positions inégales ou d'écart ; ajuster jusqu'à ce que les bureaux soient plats et serrés, puis resserrer les vis. 2. Si votre problème n'est toujours pas résolu, n'hésitez pas à nous contacter.
Cadre en acier	Le cadre en acier est plié, cassé, peint, rouillé ou endommagé.	Vous pouvez nous contacter et nous vous répondrons dans les 24 heures. Vous pouvez également nous contacter par courrier électronique après-vente.
	La table est instable après avoir été assemblée.	<ol style="list-style-type: none"> 1. Vérifier que les vis sont bien serrées 2. Lisez l'ensemble du manuel, vérifiez si des pièces ont été mal installées ou manquent à l'assemblage. 3. Si votre problème n'est toujours pas résolu, n'hésitez pas à nous contacter.
	Des dommages d'origine non humaine ont été constatés lors de l'utilisation de la table.	Si le produit est endommagé pour des raisons non humaines, veuillez conserver le produit et nous envoyer des photos. Nous déterminerons la cause de l'endommagement du produit dans les 48 heures et vous fournirons une solution satisfaisante.

Problemas que puede encontrar

PARTE	PROBLEMA	SOLUCIÓN
Producto completo	Faltan piezas, están defectuosas o hay piezas equivocadas en el paquete.	Puede ponerse en contacto con nosotros y le responderemos en 24 horas. También puede ponerse en contacto con nosotros a través del correo electrónico de posventa.
	Problemas al leer las instrucciones o completar el montaje.	Puede ponerse en contacto con nosotros y le responderemos en 24 horas. También puede ponerse en contacto con nosotros a través del correo electrónico de posventa.
	Daños de origen no humano durante el uso.	Si el producto está dañado por causas no humanas, consérvelo y envíenos fotos del mismo. Averiguaremos la causa del daño del producto en un plazo de 48 horas y le ofreceremos una solución satisfactoria.
Superficie de la mesa	La superficie de la placa está rota, rayada o le faltan algunos agujeros para los tornillos.	Puede ponerse en contacto con nosotros y le responderemos en 24 horas. También puede ponerse en contacto con nosotros a través del correo electrónico de posventa.
	Los agujeros de los tornillos del tablero y del marco de acero no están alineados.	<ol style="list-style-type: none"> 1. Por favor, apriete los tornillos de la placa en un 70%, no los apriete del todo. 2. Ajuste el tablero y el marco de acero hasta que los orificios de los tornillos estén alineados, luego apriete todos los tornillos
	El tablero del escritorio es desigual o no apretado que tiene lagunas después de ser ensamblado.	<ol style="list-style-type: none"> 1. Afloje los tornillos en las posiciones desiguales o con huecos; ajústelos hasta que los escritorios queden planos y ajustados y, a continuación, apriete los tornillos. 2. Si el problema sigue sin resolverse, no dude en ponerse en contacto con nosotros.
Estructura de acero	El marco de acero está doblado, roto, pintado, oxidado o dañado.	Puede ponerse en contacto con nosotros y le responderemos en 24 horas. También puede ponerse en contacto con nosotros a través del correo electrónico de posventa.
	La mesa es inestable después de ser montada.	<ol style="list-style-type: none"> 1. Compruebe si los tornillos están apretados 2. Lea todo el manual, compruebe si hay alguna pieza mal instalada o falta alguna ensamblada. 3. Si el problema sigue sin resolverse, póngase en contacto con nosotros.
	La mesa presenta daños no causados por el ser humano durante su uso.	Si el producto está dañado por causas no humanas, conserve el producto y envíenos fotos del mismo. Averiguaremos la causa del daño del producto en un plazo de 48 horas y te ofreceremos una solución satisfactoria.

Problemi che si possono incontrare

PARTE	PROBLEMA	SOLUZIONE
Prodotto intero	Le parti sono mancanti, difettose o sbagliate nella confezione.	Potete contattarci e vi risponderemo entro 24 ore. Oppure, potete raggiungerci tramite e-mail post-vendita.
	Problemi durante la lettura delle istruzioni o il completamento del montaggio.	Potete contattarci e vi risponderemo entro 24 ore. Oppure, potete raggiungerci tramite e-mail post-vendita.
	Danni causati dall'uomo durante l'uso.	Se il prodotto è danneggiato per cause non umane, si prega di conservare il prodotto e di inviarci delle foto. Accerteremo la causa del danno al prodotto entro 48 ore e vi forniremo una soluzione soddisfacente.
Superficie del tavolo	La superficie della scheda è rotta, graffiata o mancano alcuni fori per le viti.	Potete contattarci e vi risponderemo entro 24 ore. Oppure, potete raggiungerci tramite e-mail post-vendita.
	I fori delle viti sulla lavagna e sul telaio in acciaio non sono allineati.	<ol style="list-style-type: none"> 1. Serrare le viti della scheda al 70%, senza stringerle completamente. 2. Regolare il pannello e il telaio in acciaio finché i fori delle viti non sono allineati, quindi serrare tutte le viti.
	Il piano della scrivania non è uniforme o non è ben saldo e presenta spazi vuoti dopo l'assemblaggio.	<ol style="list-style-type: none"> 1. Allentare le viti nelle posizioni irregolari o con spazi vuoti; regolare fino a quando i piani di lavoro sono piatti e stretti, quindi serrare le viti. 2. Se il problema non è ancora stato risolto, non esitate a contattarci.
Telaio in acciaio	Il telaio in acciaio è piegato, rotto, verniciato, arrugginito o danneggiato.	Potete contattarci e vi risponderemo entro 24 ore. Oppure, potete raggiungerci tramite e-mail post-vendita.
	Il tavolo è instabile dopo l'assemblaggio.	<ol style="list-style-type: none"> 1. Controllare che le viti siano serrate 2. Leggere tutto il manuale, verificare se ci sono parti installate in modo errato o mancanti di assemblaggio. 3. Se il problema non può essere risolto, non esitate a contattarci.
	Si riscontrano danni non causati dall'uomo durante l'uso.	Se il prodotto è danneggiato per cause non umane, si prega di conservare il prodotto e di inviarci delle foto. Accerteremo la causa del danno al prodotto entro 48 ore e vi forniremo una soluzione soddisfacente.

We are committed to providing our customers with premium quality products and convenient customer service.

MADE IN CHINA