

ASSEMBLY INSTRUCTION FOR ACME FURNITURE

MODEL# 72310 (BASE)







Thank you for purchasing the quality product. Be sure to check all packing material carefully for small parts which may have come loose inside the carton during shipment. Separate, identify and count all parts and metal hardware. Compare with all parts list to be sure all parts are present. If any part(s) are missing or damaged, please contact your local furniture dealer. For efficient and speedy service, please indicate the model number and code letter of part(s) needed.

*****Do not fully tighten screws until fully assembled*****

DESCRIPTION	COMPONENT PARTS	
	PART NAME	Q'TY (PCS)
P2	MAIN TABLE LEG FRAME	1
P3	BASE BAR	1
P4	LEG STRETCHERS	4
P5	MOUNTING BAR	1

HAREWARES REQUIRE (FOR 1 TABLE BASE)

THE HARDWARE
IN INNER BOX

- H1  JCBC BOLT M6 x 45MM - 6 PCS
- H4  LEG ADJUSTABLE GLIDE - 4 PCS
- H5  ALLEN KEY (SHARE USE) - 1 PC
- H6  WOOD DOWEL - 8 PCS
- H7  WOOD PLUG - 8 PCS
- H8  JCBC BOLT M6 x 35MM - 2 PCS

Attention:

*** Some number parts listed on the instruction sheet may not be in parts bag as they may already be assembled.

Carefully check parts and packing materials prior to ordering replacements.

How to assemble 72310 BASE

STEP 1

H6 x 8

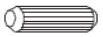

M8 x 30mm

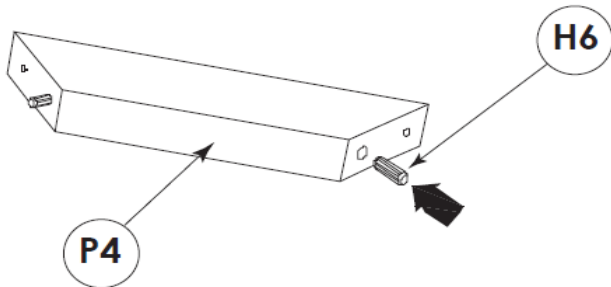

STEP 2

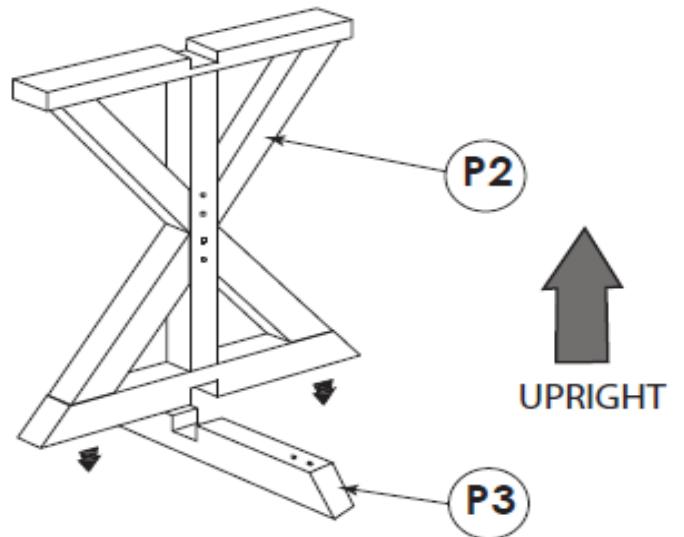

STEP 3

H1 x 4



M6 x 45mm

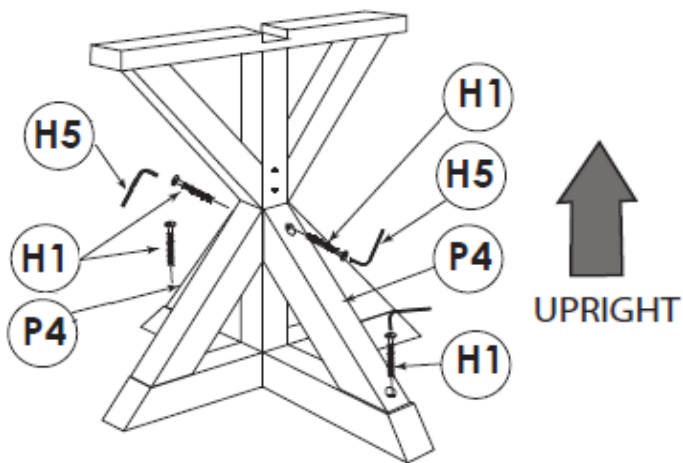

STEP 4

H1 x 2



M6 x 45mm

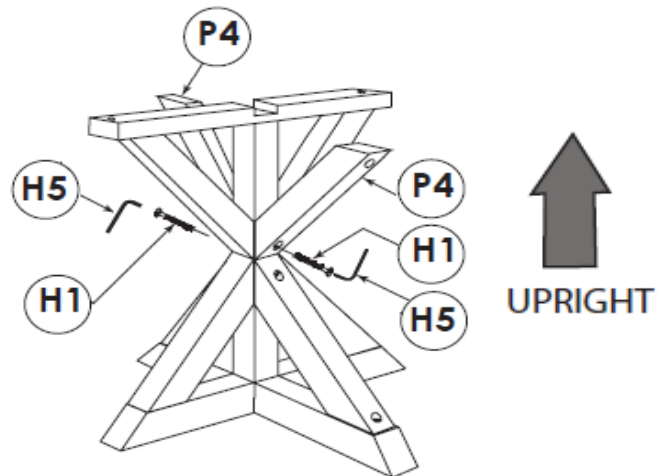

How to assemble 72310 BASE

STEP 5

H8 x 2



M6 x 35mm

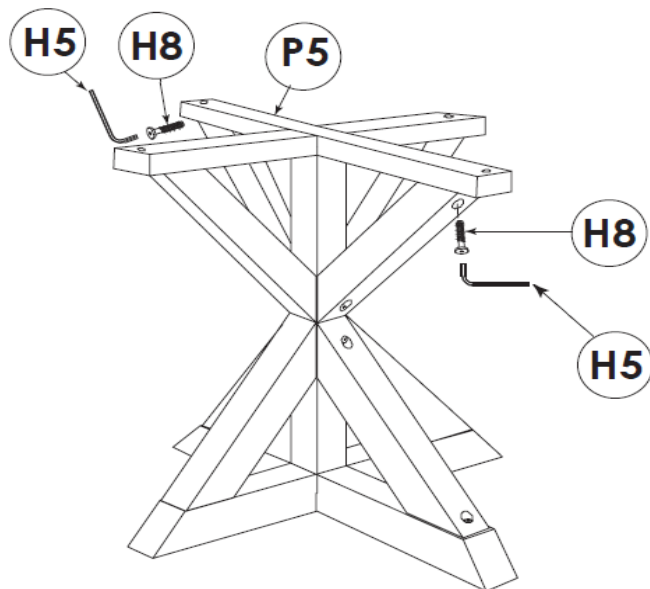

STEP 6

H4 x 4



H7 x 8

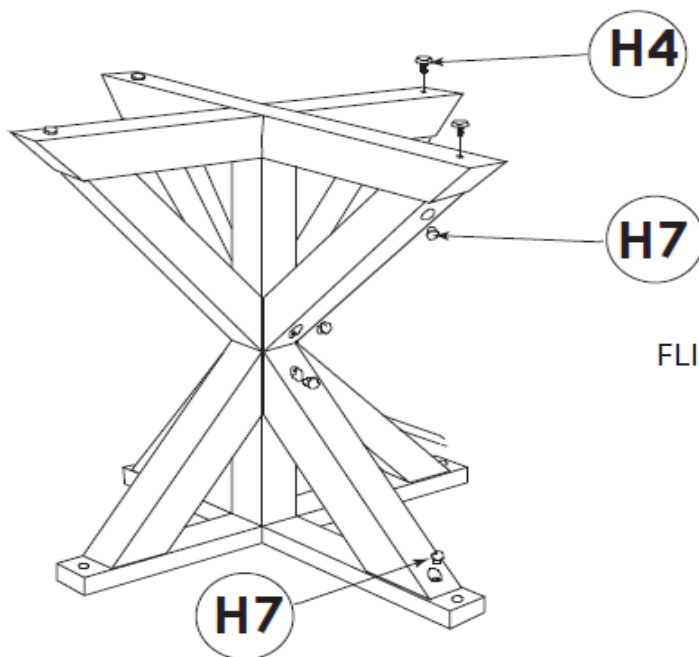

FLIP UPSIDE DOWN



ASSEMBLY INSTRUCTION FOR ACME FURNITURE



MODEL# 72310 (TOP)

Thank you for purchasing the quality product. Be sure to check all packing material carefully for small parts which may have come loose inside the carton during shipment. Separate, identify and count all parts and metal hardware. Compare with all parts list to be sure all parts are present. If any part(s) are missing or damaged, please contact your local furniture dealer. For efficient and speedy service, please indicate the model number and code letter of part(s) needed.

*****Do not fully tighten screws until fully assembled*****

	COMPONENT PARTS	
DESCRIPTION	PART NAME	Q' TY (PCS)
P1	TABLE TOP	1

HAREWARES REQUIRED (FOR 1 TABLE TOP)



- | | | |
|----|-----------------------------------------------------------------------------------|-----------------------------|
| H1 |  | JCBC BOLT M6 x 45MM - 4 PCS |
| H2 |  | SPRING WASHER - 4 PCS |
| H3 |  | FLAT WASHER - 4 PCS |

Attention:

*** Some number parts listed on the instruction sheet may not be in parts bag as they may already be assembled.

Carefully check parts and packing materials prior to ordering replacements.

STEP 7

H1 x 4 
M6 x 45mm H2 x 4 
H3 x 4 

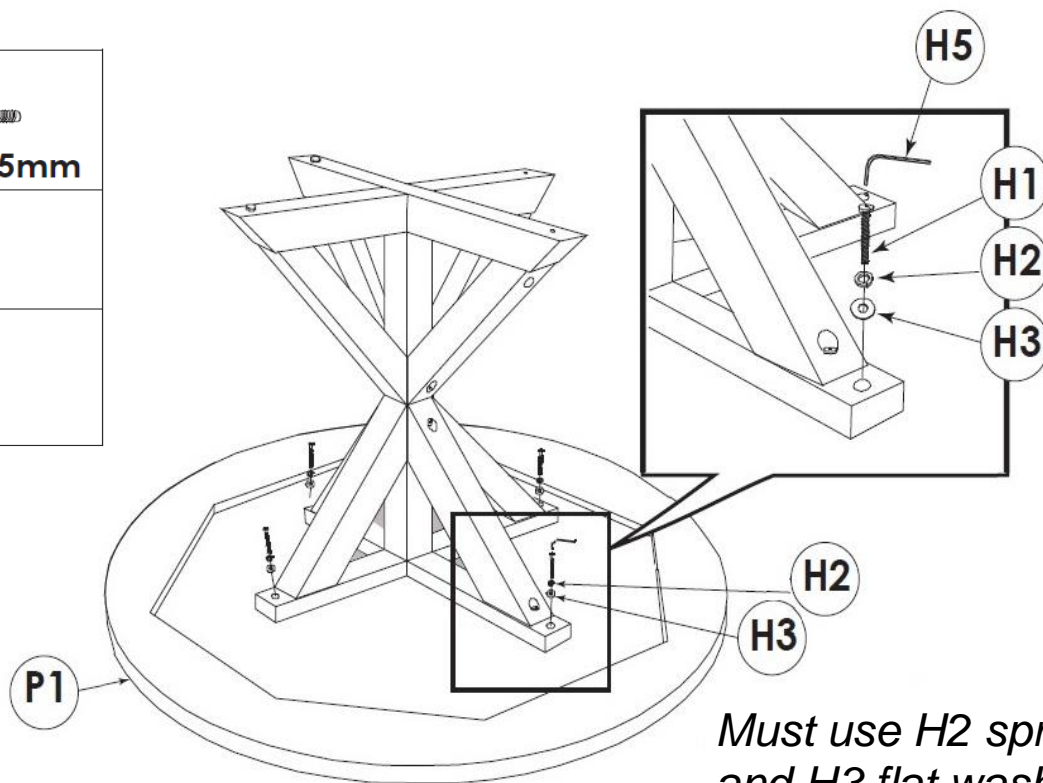



*Must use H2 spring washer
and H3 flat washer
Allen key H5 recommended
DO NOT over tighten*

ASSEMBLY INSTRUCTION FOR ACME FURNITURE









MODEL# 72312

Thank you for purchasing the quality product. Be sure to check all packing material carefully for small parts which may have come loose inside the carton during shipment. Separate, identify and count all parts and metal hardware. Compare with all parts list to be sure all parts are present. If any part(s) are missing or damaged, please contact your local furniture dealer. For efficient and speedy service, please indicate the model number and code letter of part(s) needed.

*****Do not fully tighten screws until fully assembled*****

DESCRIPTION	COMPONENT PARTS	
	PART NAME	Q'TY (PCS)
P1	CHAIR BACK	2
P2	CHAIR SEAT	2
P3	FRONT LEGS with sticker 	2
P3	FRONT LEGS	2
P4	SIDE STRETCHER with sticker 	2
P4	SIDE STRETCHER	2
P5	CROSSBAR	2

HAREWARES REQUIRED

- H1  JCBC BOLT M6 x 35MM - 4 PCS
- H2  JCBC BOLT M6 x 60MM - 8 PCS
- H3  JCBC BOLT M6 x 80MM - 8 PCS
- H4  SPRING WASHER - 20 PCS
- H5  FLAT WASHER - 20 PCS
- H6  SCREW M4 x 32MM - 8 PCS
- H7  SCREW M4 x 20MM - 4 PCS
- H8  ALLEN KEY - 1 PC

Attention:

*** Some number parts listed on the instruction sheet may not be in parts bag as they may already be assembled.

Carefully check parts and packing materials prior to ordering replacements.

How to assemble:

STEP 1:

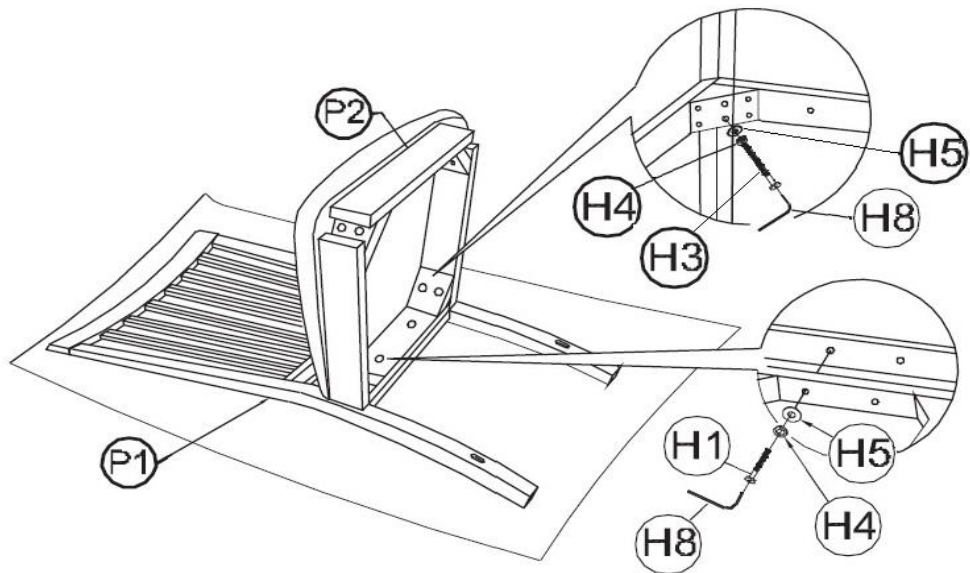

STEP 2:

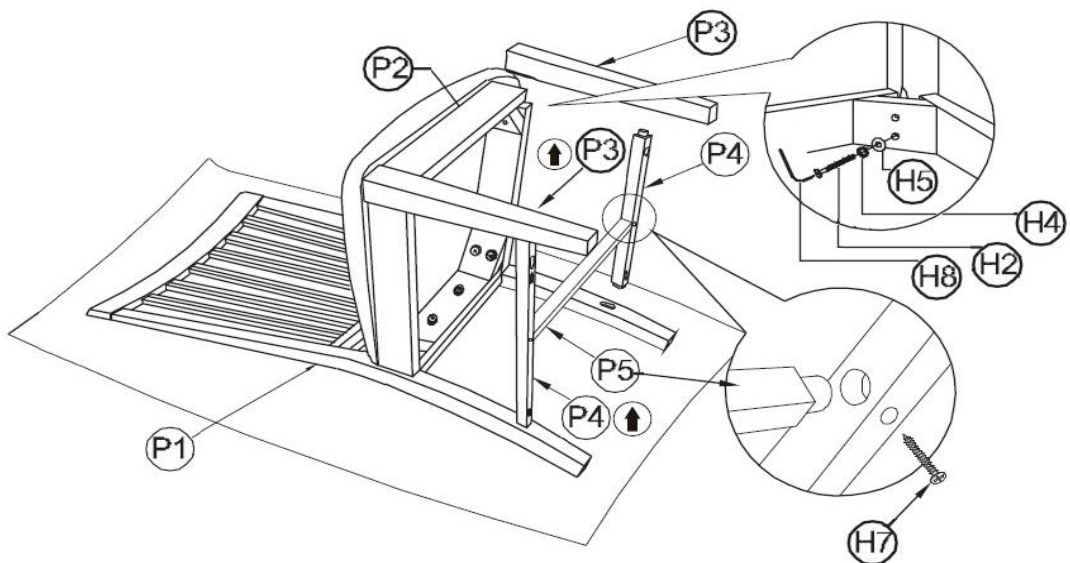

STEP 3:

