

This instruction booklet contains important safety information, please read and keep for future reference.

PARTS IDENTIFICATION

1. Ensure that all parts and components are located before beginning assembly.
Parts are labelled on the edge to help distinguish similar parts from one another.
Use this PARTS IDENTIFICATION page to help identify parts.
2. Assemble on soft surfaces to prevent damage to the product finish.

(A) BASE UNIT-1

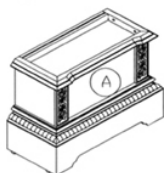

(BL) LEFT PANEL-1

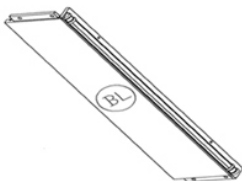

(BR) RIGHT PANEL-1



(C) BACK PANEL-1



(D) DOOR-1



(E) TOP UNIT-1

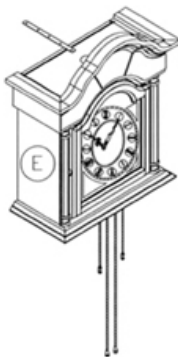

(F) WEIGHTS-2



(G) PENDULUM-1



OTHER PARTS

(R1)M6X25MM-8



(R2)ST3.5X35MM-1



(wall plug not included)

(R3)HINGE JOINTS-2

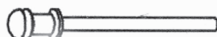

ASSEMBLY TOOL REQUIRED



(not included)

NO.2 PHILLIPS SCREWDRIVER

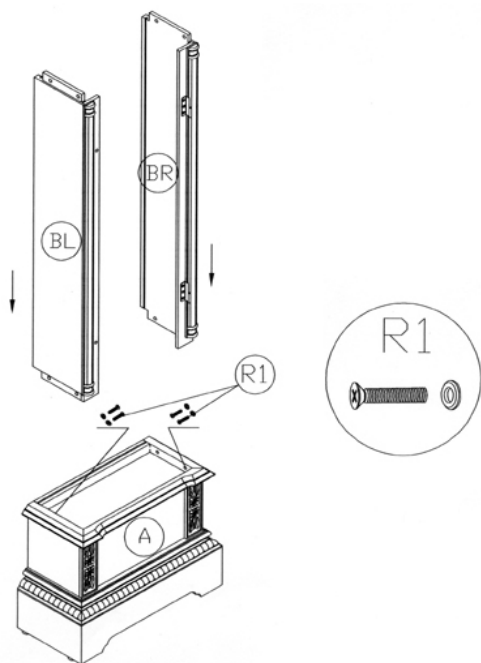

1. Place the base unit A near its final position, but leave it away from the wall until the assembly is finished. Fit the left panel BL into the groove in the base on the left side of the clock and attach it from the inside with two of the machine screws R1 (M6X25MM), using a NO. 2 Phillips screwdriver.

Repeat the process using the right panel BR on the right side of the clock.

NOTE: Do not over-tighten machine screws until Step 2 is complete.

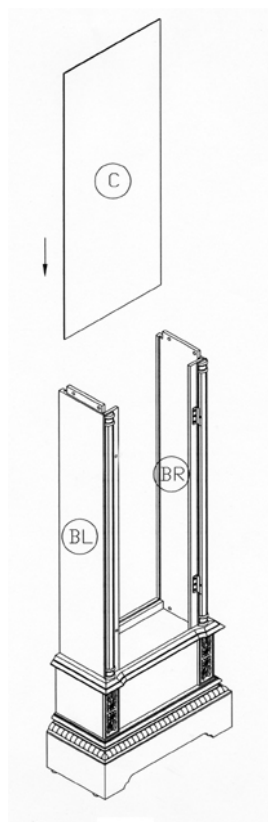

2. Slide the back panel C into the grooves in the left panel BL, the right panel BR at the back of the clock, and the base unit A.

NOTE: Tighten machine screws installed in step 1.

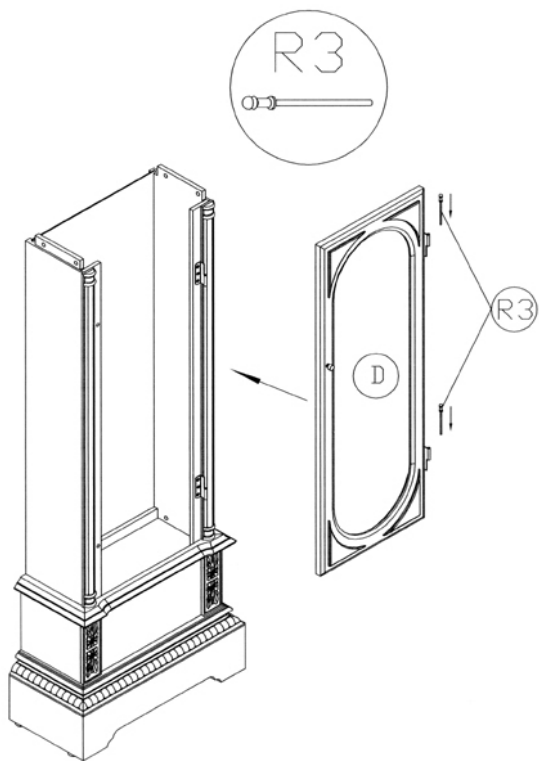

3. Slip the door D into place by lowering it over the matching hinge on the right panel BR. Take your time lining up both parts slowly and it will drop into position. Use (R3)Hinge joints.

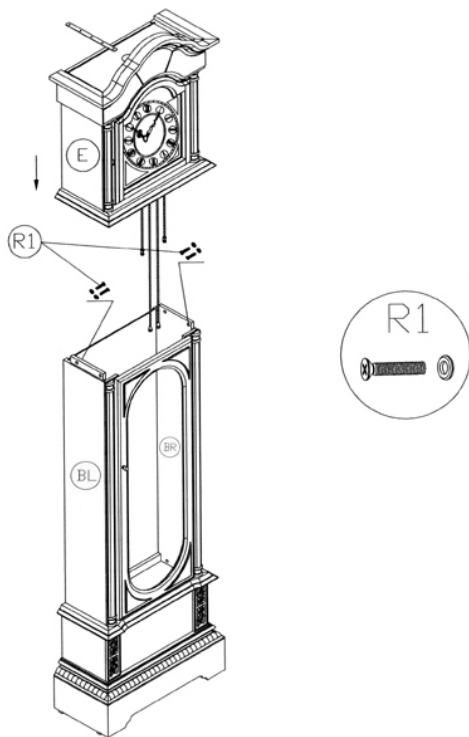

4. Carefully fit the top unit E down onto the left panel BL and right panel BR. Be sure to keep the panels straight while working. Attach the top unit with the 4 remaining machine screws (R1)M6X25MM in the same manner as the side panels.

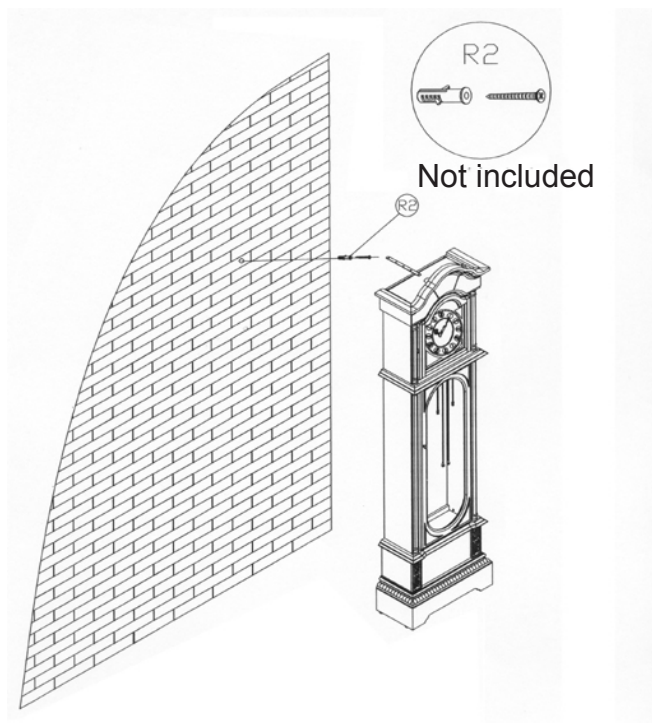

5. In order to ensure that your clock is stable, adjust the levelers under your clock. As an added safety feature, a support strap has been provided. It is fixed to the top unit A of the clock and must be attached to the wall, using screw (R2)ST3.5X35MM. Provide your own wall plug if desired.
- NOTE: If the product is dirty, wipe it with soft a cloth. Be sure you position the product in a dry location.

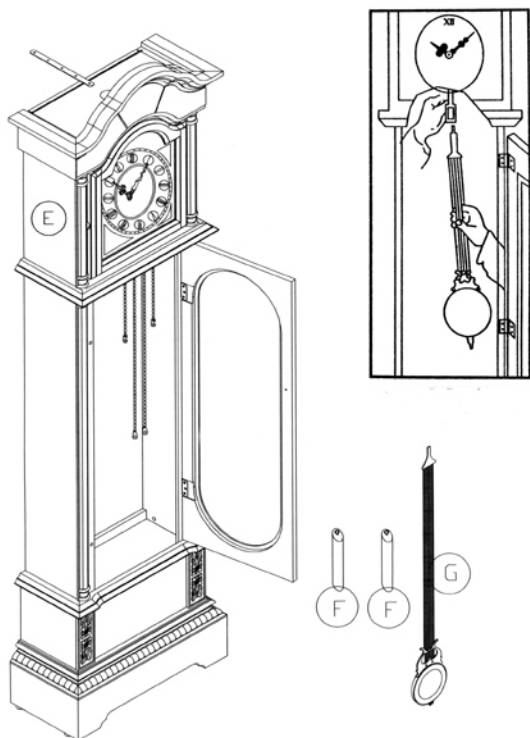

6. Hook the weights F on the end of the chains located on the bottom inside edge of the top unit E.
7. Attach the pendulum G into place so the bright side of the pendulum bob faces the front of the clock. Give the pendulum G a push sideways to get it swinging.

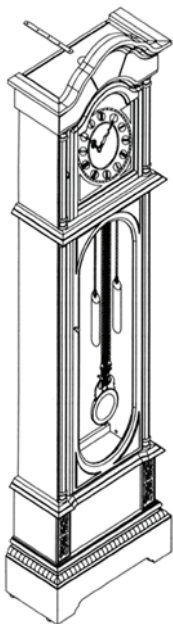

TIME AND CHIME SETTING:

CONGRATULATIONS – You have purchased a quality clock which plays the Westminster chime melody on the hour, tolls the hour and has an automatic shut-off (clock does not chime between 10:00 p.m. and 6:00 a.m.). To ensure your clock functions correctly, please follow the time and chime setting instructions precisely. The clock will chime during the day and will automatically turn off at night.

1. Pull upwards the back panel of the top unit .
2. BEFORE inserting batteries set the clock at 6:05 AM with knob A.
3. Insert 1xAA alkaline battery into the clock battery chamber, according to the positive (+) and negative (-) symbols.
4. Insert 2xAA alkaline batteries into the chime battery chamber, according to the positive (+) and negative (-) symbols. Make sure batteries are secure in the holder. The clock will chime automatically and toll 6 times.
5. Now turn hands(Using knob A) slowly to the present hour (in a clockwise direction).Remember that the clock started at 6:05 in the morning. if setting at night,lets say, to 9:20 PM, then hands will be turned thus -- 7,8,9,10,11, 12,1,2,3,4,5,6,7,8,9, then 9:20.
N.B.: When moving hands to the present time, the clock will begin chiming. Do not be concerned about this. the last strike you hear after setting the clock at appointed time will be the correct one.
6. When replacing batteries, remember that all the above must be repeated from point No 1 above. The clock must be started again at 6:05 a.m.
7. To eliminate chimes, remove the two batteries from the Chime Battery Chamber.
8. Never turn clock hands counter clockwise as it will interrupt the chime sequence and damage the clock.

N.B.: WHEN BATTERIES ARE LOW, CHIMES WILL NOT REMAIN CO-ORDINATED WITH THE TIME ON THE CLOCK. WHEN THIS HAPPENS, REPLACE WITH NEW ALKALINE BATTERIES AND RESET CLOCK AS ABOVE.

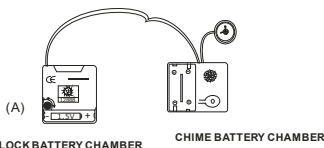

CLOCK BATTERY CHAMBER

CHIME BATTERY CHAMBER

PENDULUM SETTING:

1. Insert 2xC Alkaline batteries into the pendulum battery chamber according to the positive (+) and negative (-) symbols.
2. For transport security, the small black plastic pendulum (B) may be attached to the case (C) to prevent it from swinging.
3. At (D) use thumb pressure to gently push towards the right to loosen the pendulum and allow it to swing freely.

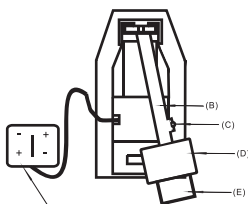

PENDULUM BATTERY CHAMBER

Battery-operated. Requires batteries. Do not mix old and new batteries. Do not mix alkaline, standard batteries (carbon-zinc) or rechargeable (nickel-cadmium) batteries.