

SeaSpark

Stand Mixer Instruction Manual

Model: SM-2548



Rated voltage: 120V~

Frequency: 60Hz

Power consumption: 300W

Keep this manual for future reference and pass it on with the equipment to any future users

PS : The appliance must only be supplied at safety extra low voltage corresponding to the marking on it.

General Safety Instructions

Read the operating instructions carefully before putting the appliance into operation and keep the instructions including the warranty, the receipt and, if possible, the box with the internal packing. If you give this device to other people, please also pass on the operating instructions.

- Read all instructions.
- To protect against risk of electrical shock do not put base in water or other liquid.
- This appliance is not intended for use by persons (including children) with reduced physical, sensory, or mental capabilities, or lack of experience and knowledge, unless they are closely supervised and instructed concerning use of the appliance by a person responsible for their safety. Close supervision is necessary when any appliance is used by or near children. Children should be supervised to ensure that they do not play with the appliance.
- Turn the appliance OFF, then unplug from the outlet when not in use, before assembling or disassembling parts and before cleaning. To unplug, grasp the plug and pull from the outlet. Never pull from the power cord.
- Avoid contacting moving parts.
- Do not operate any appliance with a damaged cord or plug or after the appliance malfunctions, or is dropped or damaged in any manner. Contact the manufacturer at their customer service telephone number for information on examination, repair, or adjustment.
- The use of attachments not recommended or sold by the manufacturer may cause fire, electric shock or injury.
- Do not use outdoors.
- Do not let cord hang over edge of table or counter.
- Keep hands, hair, clothing, as well as spatulas and other utensils away from beaters during operation to reduce the risk of injury to persons, or damage to the mixer.
- Remove beaters from mixer before washing.
- Household use only.

Special safety Instructions for this Machine

- Only operate this machine under supervision.
- Do not interfere with any safety switches.
- Do not insert anything into the rotating hooks while the machine is working.
- Place the machine on a smooth, flat and stable working surface.
- Do not insert the mains plug of the machine into the power socket without having installed all the necessary accessories.

This appliance has a polarized plug(one blade is wider than the other). To reduce the risk of electric shock,this plug will fit in a polarized outlet only one way. If the plug is not fully plugged into the socket,reverse the plug.if it still does not fit, contact a qualified electrician.Do not modify the plug in any way.

Name of different parts

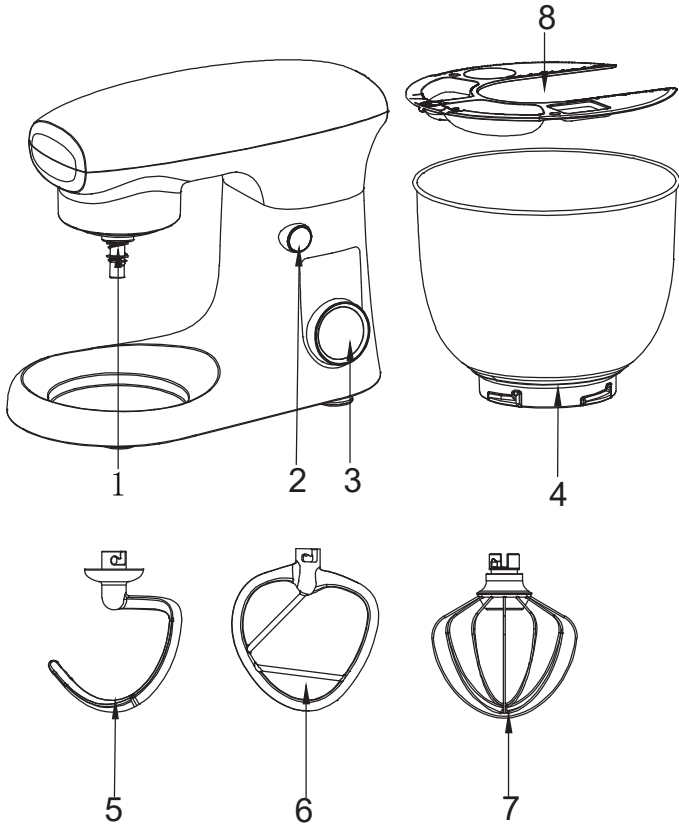

Main parts and standard parts:

1	Output shaft	5	Dough hook
2	Rise button	6	Beater
3	Speed button	7	Whisk
4	Bowl	8	Bowl cover

How to use the machine

- (1) Before use, wash the accessories by clean water, rinse and dry.
- (2) Place the machine on a flat, clean and dry table, press the machine head with your hand, and then rotate (or press down) the head-up button (2) Step1 on the fuselage will automatically lift up. (PG1&2).
- (3) Weigh out the ingredients and water to be processed into the mixing bowl, and then assemble the mixing bowl (4) on the machine Step2, turn clockwise until the buckle is turned into lock Step3. (PG2) Do not exceed the maximum total weight of the dough
- (4) Install the required accessories (5), (6), (7) (only one of the three can be used at a time) on the head stirring output shaft (1) Step3, align the slot will push the accessories until the apex Step4, (PG3&4)
- (5) Put the pot cover into the stirring end of the machine Step6 according to PG5.
- (6) Press the head of the machine, the machine will automatically lock the head button (2) step 7, which is in the horizontal position; (PG6)
- (7) then plug in the plug and turn on the power switch.
- (8) Control speed knob (3) to the required speed - start mixing;
- (9) After the dough meets the requirements, turn the speed knob (3) back to gear 0 to finish.
- (10) Press the head of the machine with your hand, turn (or press down) the head-up knob (2), lift the upper body, turn the mixing bowl counterclockwise, remove the mixing bowl, and remove the dough.
- (11) Switch off the appliance and disconnect from supply before changing accessories or approaching parts that move in use.



FG1



FG2

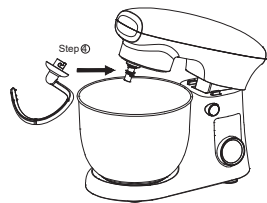

FG3

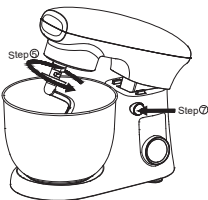

FG4

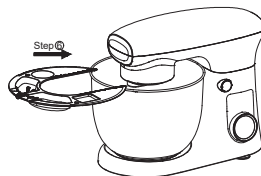



FG5



FG6

Suggestion

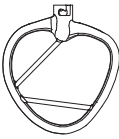
Adjusting the Levels and Using the Hook for not more than 0.9kg of Mixture

Accessories	Picture	Speed	Time (min)	Maximum	Operation method
Dough hook		1-7	3-5	585g flour+315g water	1/2 speed run for 10s, the 3/4 speed run for 10s, and then the 5/8 speed run for 2 min to 4 min to form a cluster.
Beater		1-8	3-10	660g flour+840g water	2 speed run for 20s, the 8 speed run for more than 2min40s
Whisk		8-10	3-10	3 egg whites (min)	Open 10 speed to run 3min above.

Recipe

Linseed Bread Rolls

Ingredients: 30g linseed, 40g water, 250g bread flour, 3g dry yeast, 30g sugar, 3g salt, 10g milk powder, 20g butter, 15g egg liquid

Process:

1. Soak the 30g linseed into 40g water for 12 hours
2. Put 250g bread flour, 3g dry yeast, 30g sugar, 3g salt, 10g milk powder, 150g water into the mixing bowl, use dough hook to knead the ingredients to dough at levels 1-6, and then add 20g butter and continue to knead the dough until smooth, then add soaked linseed until the dough is well kneaded. Cover with preservative film and allow fermenting to double its size in a warm place.
3. Knead thoroughly once more, remove from the bowl and divided into six rolls. After being rounded, cover the rolls and allow fermenting at 38°C for 1 hour.
4. After the fermentation is finished, brush the surface of the bread with egg liquid, put it on penultimate layer in the preheated oven, set fire up and down at 180°C and bake for 20 minutes, then remove the mold and put it on the grill to cool down.

Toast bread

Ingredients: 270g high-gluten flour, 30g low-gluten flour, 1 egg, 3g salt, 55g sugar, 4g yeast, 80g light cream, 10g milk powder, 90g water.

Process:

1. Put all the ingredients into the mixing bowl, use dough hook to knead the ingredients to dough at levels 1-6.
2. Keep the mixture in a warm place and allow fermenting to double its size.
3. Knead thoroughly once more, remove from the bowl and divided it into 3 portions, cover the dough with preservative film for 15 minutes
4. Take one portion and roll it into a tongue shape, fold both sides toward the middle, and roll it up from bottom to top. After all three are rolled, cover the rolls with preservative film for 15 minutes
5. After finishing 3 servings, put them into the mold for the 2nd fermentation, ferment to 80% of the mold height. set fire up and down at 170°C and bake for 40 minutes, then remove the mold and put it on the grill to cool down.

Homemade Pizza

Raw materials: 170g high-gluten flour, 100g water, 1.5g edible salt, 15g white sugar, 2g yeast, 15g butter, and some stuffing.

Process:

1. Put 170g high-gluten flour, 100g water, 1.5g edible salt, 15g sugar, and 2g yeast into the mixing bowl. Mix with dough hook at levels 1-6. After kneading into dough, add butter and continue to knead until it can pull out to be a flexible film
2. Leave the dough fermenting to double its size in a warm place.
3. During the fermentation, the pizza stuffing can be made and reserved for future use.
4. Knead thoroughly once more, take half of the dough to roll it round and relax for 5 minutes, then use a rolling pin to gently roll it to the size of a pizza pan, put it on the pizza pan, press it around the pizza pan with your hands, finally use a fork to make small holes.
5. Set the upper and lower tube heating mode of the oven, preheat 200°C. Brush the pie mold base with olive oil first, then scoop the pizza sauce and spread it evenly, and then, sprinkle a little mozzarella cheese and shredded onion, put the 8-inch pizza pan in the second layer of the preheated oven and bake for 8 minutes.
6. When the time is up, take out the pizza pan and spread a layer of bacon. Here you can put your favorite food and prepared stuffing in order.

7. Put it in the preheated oven, set the working time for 15 minutes until the cheese is melted and the crust is golden.

Butter bread

Ingredients: 375g high-gluten flour, 180g milk, 35g butter, 30g sugar, 11g milk powder, 4g yeast, 3g salt, 1 egg

Process:

1. Put all the ingredients into the mixing bowl except the butter, leaving 10g of egg for the final brushing.
2. Use dough hook to mix at levels 1-6, after forming dough, add softened butter and continue kneading into glove film status.
3. Cover the mixture with preservative film and allow fermenting to double its size in a warm place.
4. Knead thoroughly once more, remove from the bowl and divided it into 10 portions. Take a portion of the dough and roll it into an oval shape, then roll it up from top to bottom.
5. Place the greased paper on the baking tray, then put the rolled bread dough on the tray, allow fermenting to double its size in a warm place.
6. Brush the egg liquid on the bread dough surface, preheat the oven to 160°C, put the bread dough at the middle layer and bake for 20 minutes.

French bread

Ingredients: 250g high-gluten flour, 50g low-gluten flour, 150g water, 10g sugar, 3g yeast powder, 1g edible salt.

Process:

1. Put all the ingredients into the mixing bowl, use the dough hook to mix at levels 1-6, and knead the dough into a dough shape.
2. Cover the mixture with preservative film and allow fermenting to double its size in a warm place.
3. Knead thoroughly once more, remove from the bowl and divided it into 4 portions. Take a portion of the dough and roll it into an oval shape, then roll it up from top to bottom.
4. Then cover with preservative film and allow fermenting to double its size.
5. Brush the surface with sesame oil, preheat the oven to 180°C, put the bread dough at the middle layer and bake for 20 minutes.

Original cake

Ingredients: 100g cake flour, 5 eggs, 50g edible oil, 80g sugar, a small amount of lemon juice, 55g milk.

Process:

1. Separate the egg white and egg yolk, add 20g sugar into the egg yolk, mix with egg beater at level 10 until the sugar is completely melted. Add milk and continue to stir evenly at level 10
2. Pour edible oil and continue beating until fully emulsified.
3. Pour the cake flour through a sieve, and stir evenly into a fine egg yolk paste.
4. Put a few drops of lemon juice into the egg white, add sugar in three times and beat with an egg beater until it is cotton-like.
5. Take 1/3 of the egg white, put them in the egg yolk paste and stir evenly, pour the paste back to the remaining egg white and stir evenly to a fine cake paste
6. Brush edible oil on the surface of cake mold, then pour the cake paste into the mold
7. Preheat the oven to 150°C, set upper and lower pipe heating mode and baking time 50 minutes, then bake it till golden color.

Chocolate cake

Ingredients: 150g egg liquid, 50g pure milk, 40g cocoa powder, 80g white sugar.

Process:

1. Add 150g egg liquid, beat with egg beater at level 10 until it is cotton-like, then take it out and set aside
2. Put 80g white sugar, 50g milk, and 40g cocoa powder into a bowl and stir into a fine powder with a stirring paddle at level 10.
3. Pour the prepared fine powder into the beaten egg liquid and mix well.
4. Pour the mixed raw materials into the oil-brushed baking tray mold and put it in the oven for baking at 180°C.
5. After being baked and shaped, take them out from the mold and wait for cooling down before eating

Chocolate ice cream cake

Ingredients: 140g cream cheese, 140g dark chocolate, 220g milk, 100g powdered sugar, 240g whipped cream, 2g edible salt.

Process:

1. The outside of the square mold is wrapped with tin foil, and put a circle of baking paper inside
2. Add powdered sugar and a pinch of salt into cream cheese and mix it with a stirring paddle.
3. Chop the dark chocolate and heat it to melt, pour the melted chocolate into the cheese, then use a stirring paddle to stir evenly. Take it out and place it on a tray for later use.
4. Put whipped cream in the pot and then stir until it is almost cotton-like.
5. Add the whipped cream in 2 times into the chocolate cheese and stir evenly, then pour the milk into it in 2 times and mix it well again.
6. Finally, pour it into the mold and put it in the refrigerator for several hours. Take it out and de-mould it.

Analysis of common problems

Phenomenons	causes	Solutions
The machine suddenly stops working during use.	It may be that the machine runs too long, or the ambient temperature is too high, resulting in the machine's motor temperature being too high; the machine starts the overheating protection program, automatic shutdown.	Gear reset to "0", unplug the power, wait for the machine to return to room temperature can be restarted (generally need 15-30 minutes, the room temperature varies cooling time).
Turning the gear knob machine does not run	Check if the plug is in good contact with the socket.	Verify that the power plug is plugged into the outlet.
	Check if the power is out.	Wait for power before operating
	Check if the rise button spring back in place.	Make sure the headstock is stuck in place.
Excessive noise when the machine is running	<ol style="list-style-type: none"> ①The machine will work louder in high gear than in low gear. ②The amount of food stirred is too large, resulting in overloading the machine. ③Voltage is unstable. ④Working time is too long. 	<ol style="list-style-type: none"> ① Choose the right gear to stir food according to the recommendations in the manual ② Reduce the amount of stirring. ③If the voltage is unstable, wait for the voltage to stabilize before using. ④If the working time is too long, stop and cool down for a while before using.
The machine speed drops, or the speed is unstable	<ol style="list-style-type: none"> ① Whether the room temperature is low, causing the lubricant in the machine to harden. ②The ingredients stirred are too hard and too much, resulting in too much load on the machine. ③Whether the voltage suddenly becomes low. 	<ol style="list-style-type: none"> ①Remove the mixing bowl and let the machine idle for 5 minutes to soften the lubricant in the machine and restore the speed stability. ②Reduce the mixing volume and let the machine work according to the normal workload. ③When the voltage is stable, use the machine again.
Machine swaying and shaking when working	<ol style="list-style-type: none"> ①Check if the foot pad on the base is off. ②Whether the machine is placed on a smooth and flat countertop for use. 	<ol style="list-style-type: none"> ①Check if the foot pad on the base is off. ②Place on a smooth and flat countertop for use
The headstock can't spring back to reset after putting on the anti-splash cover and mixing bowl	Check that the anti-splash cover is in place and the mixing bowl is assembled.	Rotate the anti-splash cover and assemble it in place, and assemble the mixing pot in place.
Dough darkening found after use	Black powder falls onto the dough at the mixing head.	Please check that the mixing head and hook are dry and that no water or dust is present on the surface before use.

Cleaning

Body Cleaning	<ol style="list-style-type: none">1. Do not immerse the machine in the water. Do not use water to shower directly on top of the machine to prevent the host body from entering the water to avoid short circuits, electric shock, leakage, rust, and other failures.2. Do not use a dripping wet towel to wipe the machine3. Do not use detergent/vinegar/salt and other corrosive, strongly acidic, strong alkaline cleaning products to clean the machine body, otherwise accessible to damage the machine's surface.4. Do not use sharp and rough tools such as wire balls to brush the accessories. Otherwise, it is easy to damage the surface of the accessories.
Accessory Cleaning	<ol style="list-style-type: none">1. Do not put the cast aluminum parts into the dishwasher or wash them with corrosive, strongly acidic, or alkaline cleaning products. Please do not put them into the dishwasher for cleaning. (Except for stainless steel parts or surface-treated Teflon parts and electrophoresis parts)2. Do not soak for a long time in detergent, saltwater, vinegar, and other corrosive liquids; use in time to clean accessories.3. After cleaning, dry the accessories, mainly to keep the internal parts dry in time.
Special Cleaning	<ol style="list-style-type: none">1. The rotating output shaft will produce a bit of black trace due to high speed and friction when the machine is working. After each use, please clean it promptly and keep the part dry.2. Pay attention to the sharp blade and related sharp edge parts or accessories.
Preservation and maintenance	<ol style="list-style-type: none">1. You can use olive oil to apply on the blade's surface, knife plate, and mixing pot to ensure the dry and wet environment to oxidize it.2. When not in use, you can cover the machine with a packaging bag and place it in a dry environment.

Disposal



Do not dispose of the device in normal domestic waste.

Dispose of the device over a registered waste disposal firm or through your communal waste disposal facility.

Observe the currently valid regulations. In case of doubt, consult your waste disposal facility.