

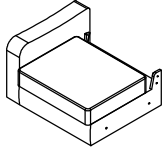









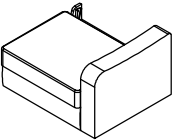

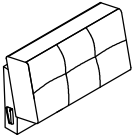
ASSEMBLY INSTRUCTION

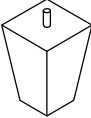
ITEM NO: F6901; F6903; F6904

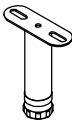
Unpack the box and place the contents on a flat, level surface. Verify that you have all the parts and hardware, including the necessary bolts and washers. **READ ALL INSTRUCTIONS AND WARNINGS BEFORE USING THIS PRODUCT. IF THERE IS ANY QUESTION ABOUT A CONDITION BEING SAFE OR UNSAFE, DO NOT USE THIS PRODUCT!**

Parts List

A 	LAF SEAT BASE 1PC	F  5/16" x 25 mm 4PCS
B 	RAF SEAT BASE 1PC	G  5/16" x 75 mm 2PCS
C 	C1 LAF BACK 1PC C2 RAF BACK 1PC	H  5/16" x 12 mm 2PCS
D 	WOODEN LEG 4PCS	I  5/16" x Ø22 mm 4PCS
E 	ADJUSTABLE METAL LEG 2 PCS	J  5/16" x Ø22 mm 8PCS
L 	PILLOWS 2 PCS	K  1PC

Step 1: Align female brackets at the back rest (C) to the male brackets at the seat base (A), (B). Insert the back rest (C) to the seat base and push it to the end. Make sure the brackets is secured in position.

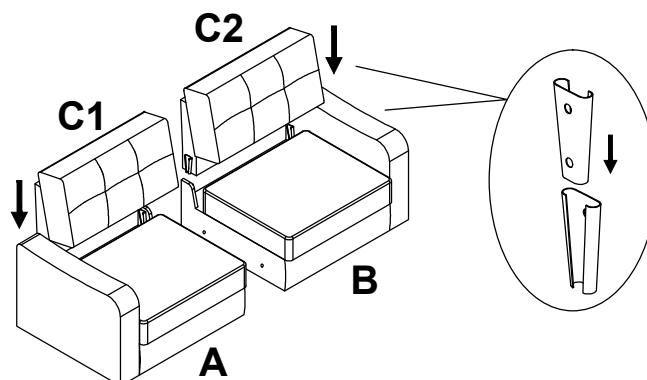

Step 2: Secure the two individual seat frame (A&B) together. Using bolt (G.J) nut (H) and allen wrench (K)

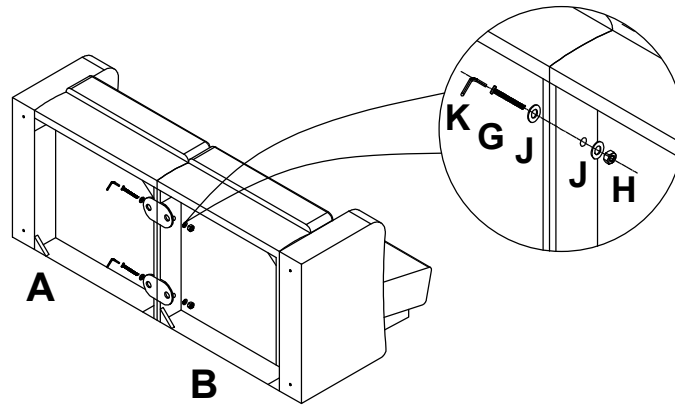

Step 3: Attach the adjustable metal leg (E) and place it on the underside of the seat base (A+B). Align the holes in the metal legs (E) with the holes in the seat base (A+B). Using the bolts (F.J) and allen wrench (K) secure the metal leg (E) to the seat base and tighten all of them firmly

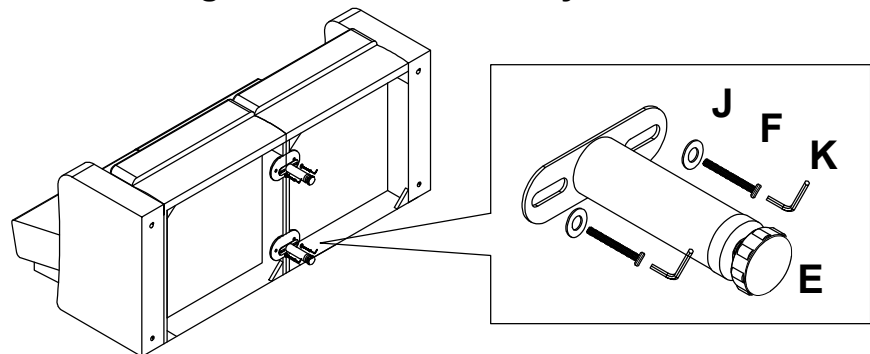

Step 4: Insert wooden leg (D) and washer (I) onto the bottom of LAF& RAF seat base (A+B). Using the adjustable metal leg (E) to level the whole seat base

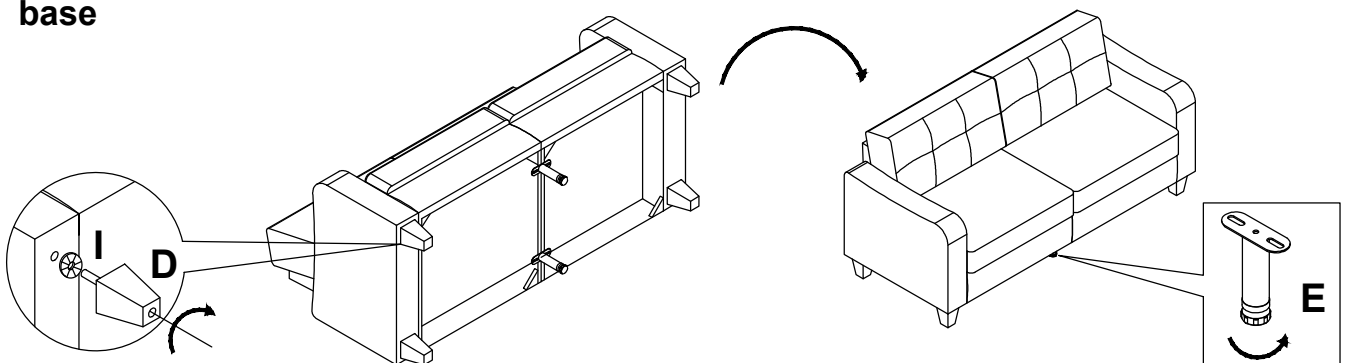

Step 5: Completed

