









ASSEMBLY INSTRUCTIONS

NO.	Parts List	Q' TY
A	 Chair Back	1
B	 Chair Seat	1
C	 Front Leg	2

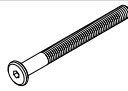
NO.	Parts List	Q' TY
H1	 Ø8 x 55mm Allen Head Bolt	4
H2	 Ø8 x 85mm Allen Head Bolt	4
H3	 Ø8 x 40mm Allen Head Bolt	1
H4	 Ø9 x Ø13mm Lock Washer	9
H5	 Ø8 x Ø20mm Flat Washer	9
H6	 4 x 110mm Allen Key	1

STEP 1

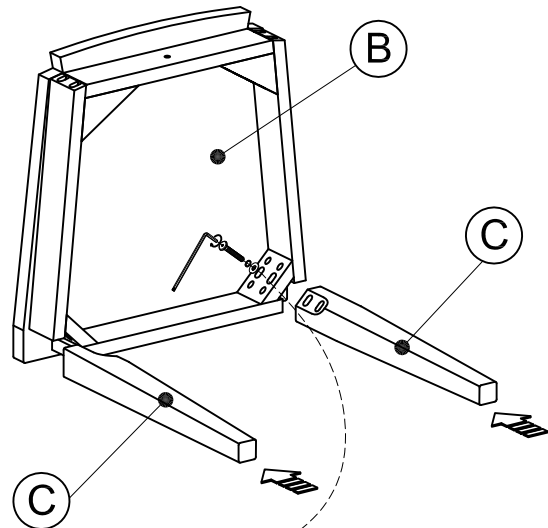
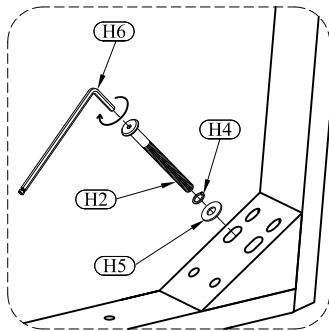
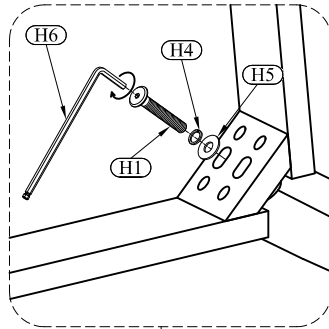

STEP 2

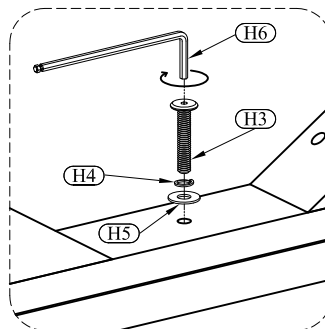
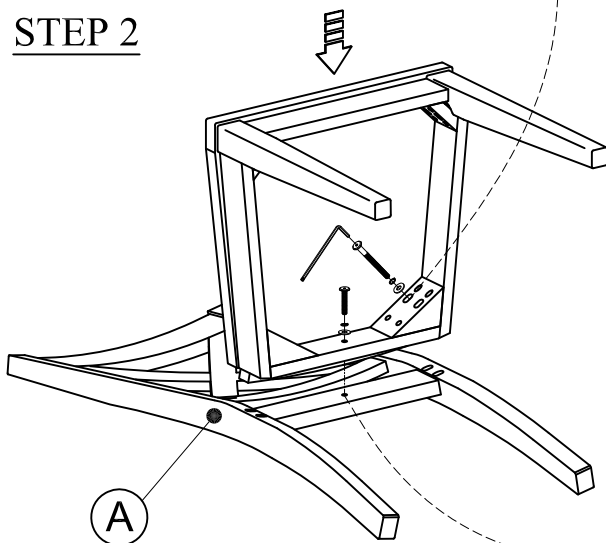

FINISH

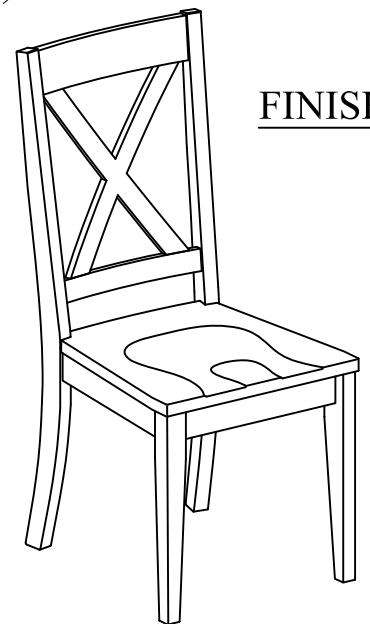

** TURN THE CHAIR TO THE STANDING POSITION.
CHECK IT'S BALANCE AND TIGHTEN ALL SCREW
TO COMPLETE THE ASSEMBLY