

MONTAGEANLEITUNGEN INSTRUCTIONS DE MONTAGE

Schwarzes PU-Luftdruckstangen-Aufbewahrungs-LED-Weichbett
Lit moelleux LED de stockage de tige de pression d'air en PU noir

GY0101(140x200)

GY0101(160x200)

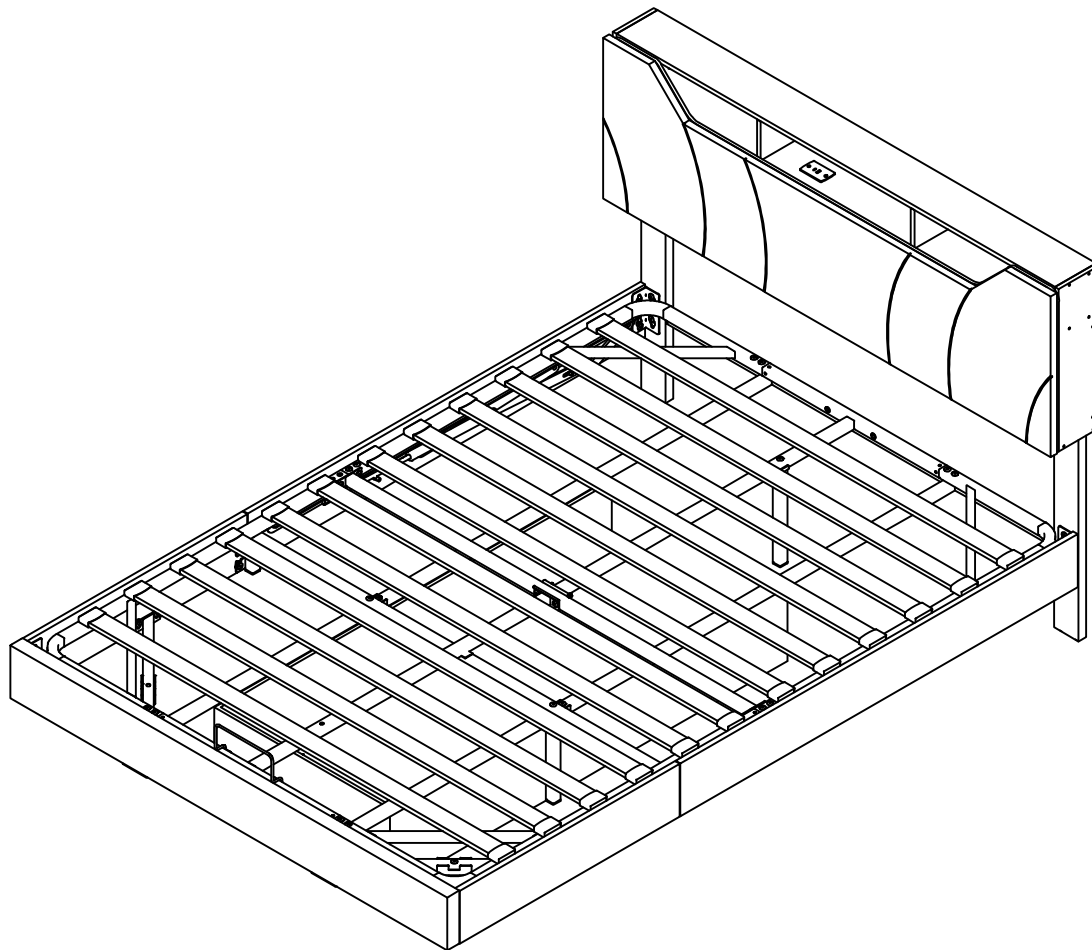

Freundlicher Kundenservice

Zufriedenheitsgarantien: Bei Problemen mit der Montage, der Qualität oder der Rückgabe können Sie sich gerne direkt an uns wenden.

Service client amical

Garanties de satisfaction : si vous rencontrez des problèmes d'assemblage, de qualité ou de retour, n'hésitez pas à nous contacter directement.

IMPORTANT/WICHTIG/ATENCION

IMPORTANT/IMPORTANTE



EN-We recommend 2 or more people to install.
DE-Wir empfehlen, dass die Montage von 2 oder mehreren Personen durchgeführt werden sollte.
ES-Recomendamos realizar el ensamble con 2 o más personas.
FR -Il est recommandé d'effectuer le montage à 2 personne(s) ou plus.
IT -È necessaria la presenza di 2 o più persone per il montaggio di questo prodotto.



EN-The expected assembly time is 1 h.
DE-Die Montagezeit beträgt durchschnittlich 1 h.
ES-El tiempo aproximado de ensamble es de 1 h.
FR-Le temps nécessaire est estimé à 1 h.
IT-Il tempo previsto per il corretto assemblaggio è di 1 h.



EN-Not intended for use by children.
DE-Nicht geeignet für Kinder.
ES-Producto no apto para niños.
FR -Produit non destiné à être utilisé par des enfants.
IT - Questo prodotto non è destinato all'uso da parte dei bambini.



EN-Keep away from fire or other heat sources.
DE-Bitte von Feuer und Hitzequellen fernhalten.
ES -Manténgase alejado de las llamas y otras fuentes de calor.
FR -Tenir à distance des flammes et autres sources de chaleur.
IT -Tenere lontano dal fuoco o da altre fonti di calore.

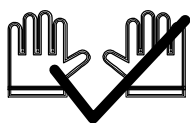

EN-We recommend wearing protective gloves. DE-Wir empfehlen das Tragen von Schutzhandschuhen. ES-Recomendamos el uso de guantes de seguridad. FR-Il est recommandé de porter des gants de protection. IT-Per il processo di assemblaggio, consigliamo fortemente l'utilizzo di guanti protettivi.



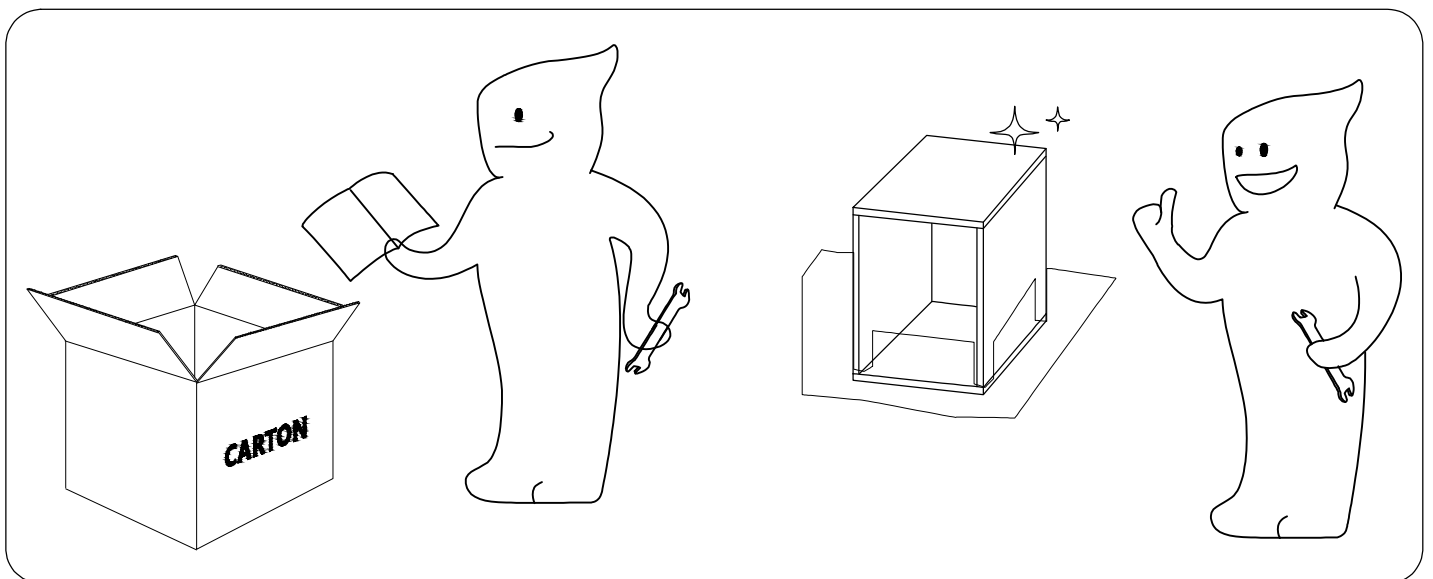
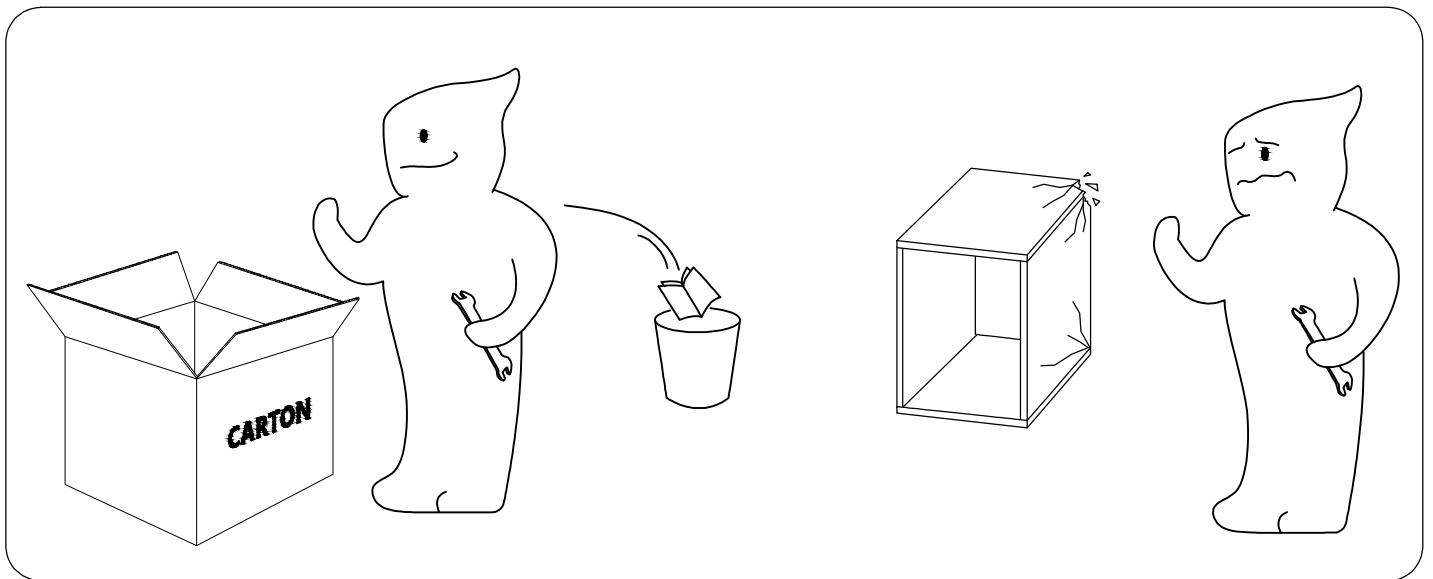



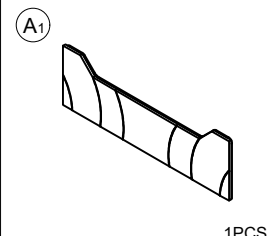
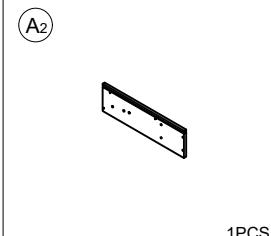
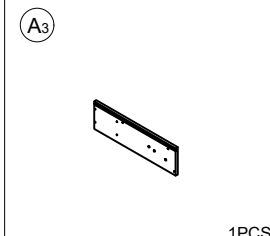
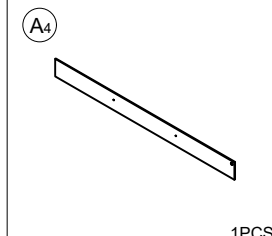
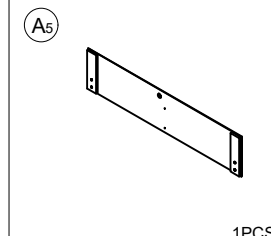
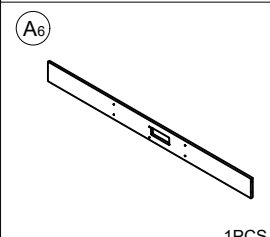
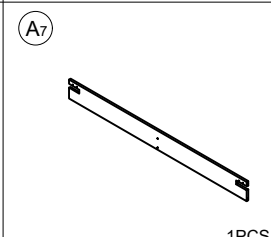
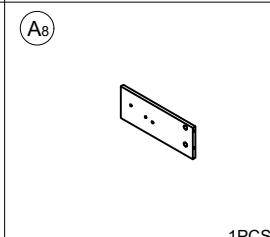
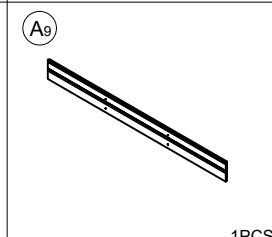
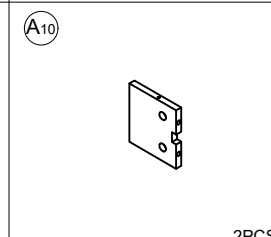
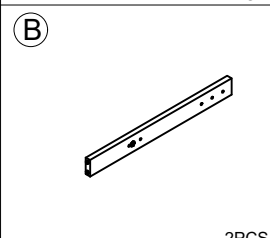
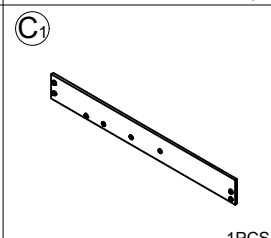
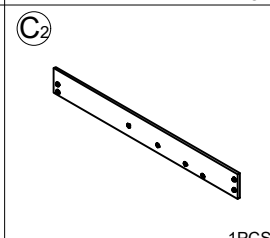
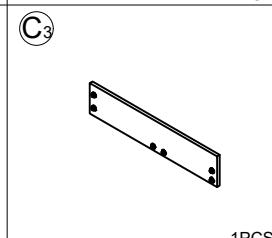
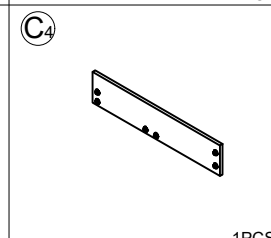
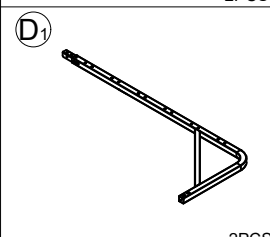
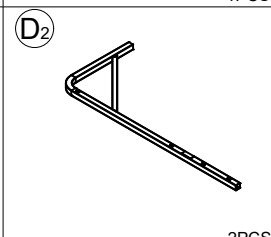
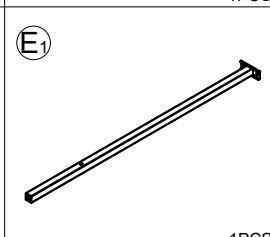
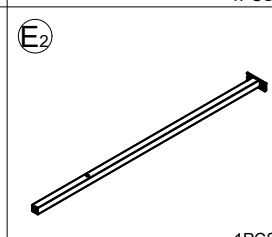
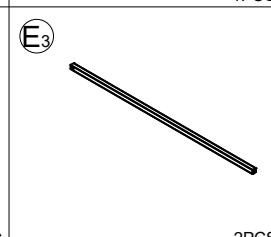
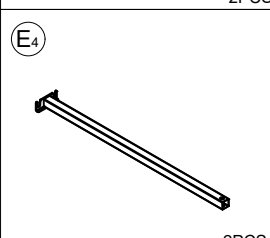
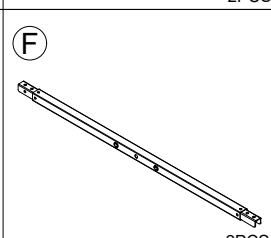
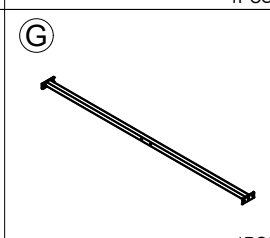
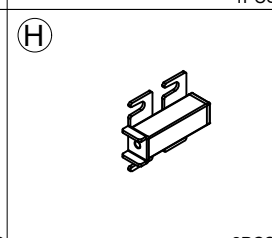
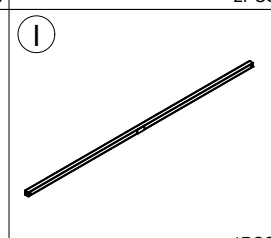
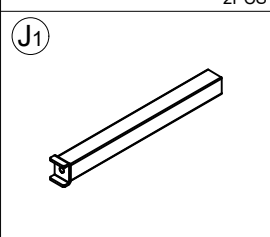
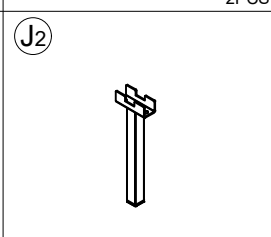
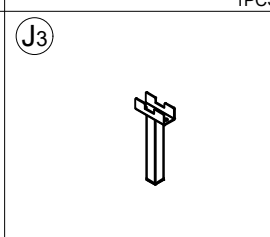
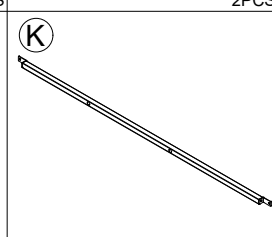
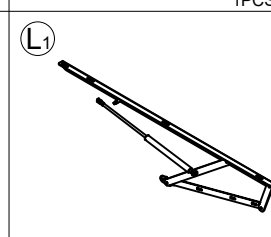
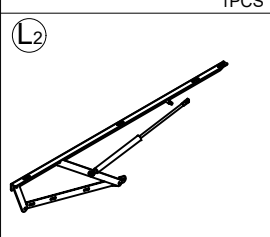
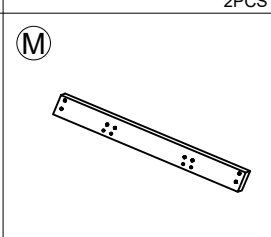
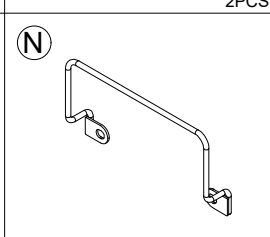
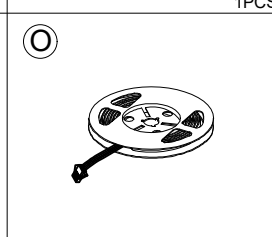
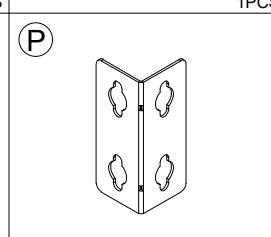



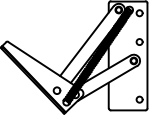
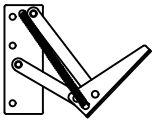
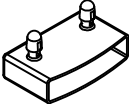
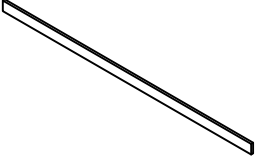
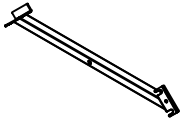

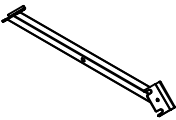
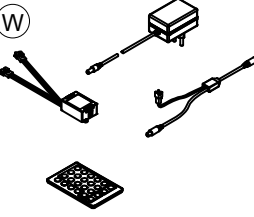
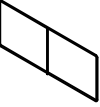
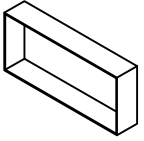

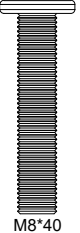
EN - Please follow the instruction manuals and use a pad to avoid damage during assembly.
DE - Bitte folgen Sie der Anleitung und verwenden Sie eine Unterlage, um Beschädigungen bei der Montage zu vermeiden.
ES - Por favor, siga las instrucciones del manual y utilice una cubierta o lona para proteger el producto y el suelo durante la instalación.
FR - Suivez les instructions de la notice et utilisez une couverture ou une bache pour protéger le produit et les sols pendant le montage.
IT - Si prega di consultare il manuale illustrativo durante il montaggio e di utilizzare un cuscinetto per evitare possibili danni.

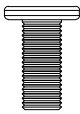
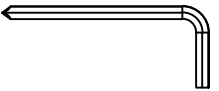

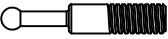
LISTE DER EINZELTEILE
LISTE D'OBJETS

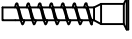
 1PCS	 1PCS	 1PCS	 1PCS	 1PCS
 1PCS	 1PCS	 1PCS	 1PCS	 2PCS
 2PCS	 1PCS	 1PCS	 1PCS	 1PCS
 2PCS	 2PCS	 1PCS	 1PCS	 2PCS
 2PCS	 2PCS	 1PCS	 2PCS	 1PCS
 1PCS	 2PCS	 2PCS	 1PCS	 1PCS
 1PCS	 1PCS	 1PCS	 1PCS	 4PCS

LISTE DER EINZELTEILE
LISTE D'OBJETS

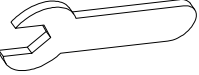
<p>Q1</p> 	<p>Q2</p> 	<p>R</p>  <p>24PCS</p>	<p>S</p>  <p>12PCS</p>	<p>T</p>  <p>1PCS</p>
<p>U</p>  <p>1PCS</p>	<p>V</p>  <p>1PCS</p>	<p>W</p>  <p>1PCS</p>	<p>X</p>  <p>2PCS</p>	<p>Y</p>  <p>1PCS</p>
<p>Z</p>  <p>1PCS</p>	<p>1</p>  <p>M8*40 17PCS</p>	<p>2</p>  <p>M8*50 4PCS</p>	<p>3</p>  <p>M8*18 36PCS</p>	<p>4</p>  <p>#4*80 1PCS</p>
<p>5</p>  <p>M8x2pcs</p>	<p>6</p>  <p>L32x6pcs</p>	<p>7</p>  <p>Ø3*10x2pcs</p>	<p>8</p>  <p>M5*30x28pcs</p>	<p>9</p>  <p>T10*Ø15x6pcs</p>
<p>10</p>  <p>M4*12x9pcs</p>	<p>11</p>  <p>#3*60 1PCS</p>	<p>12</p>  <p>1PCS</p>		

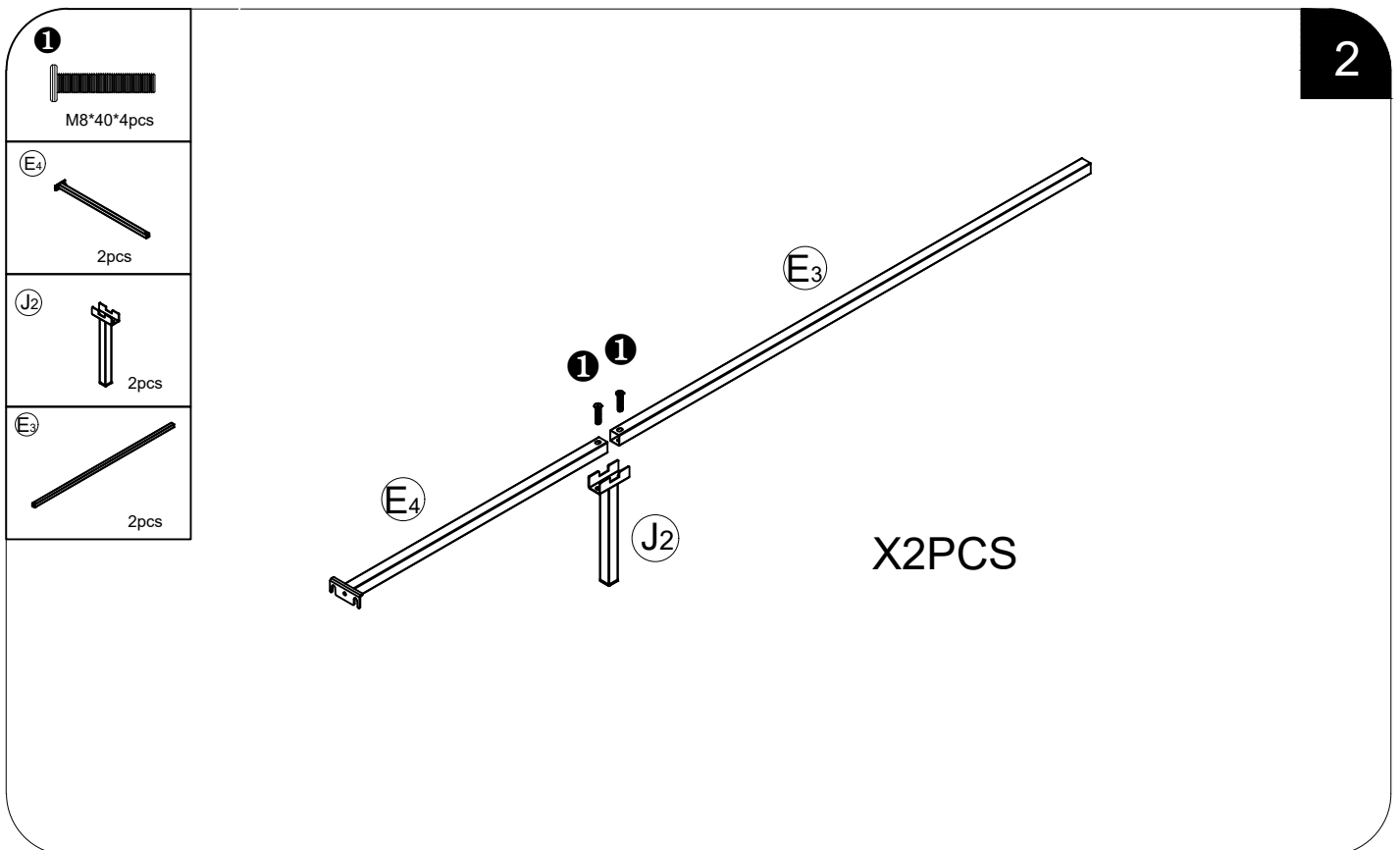
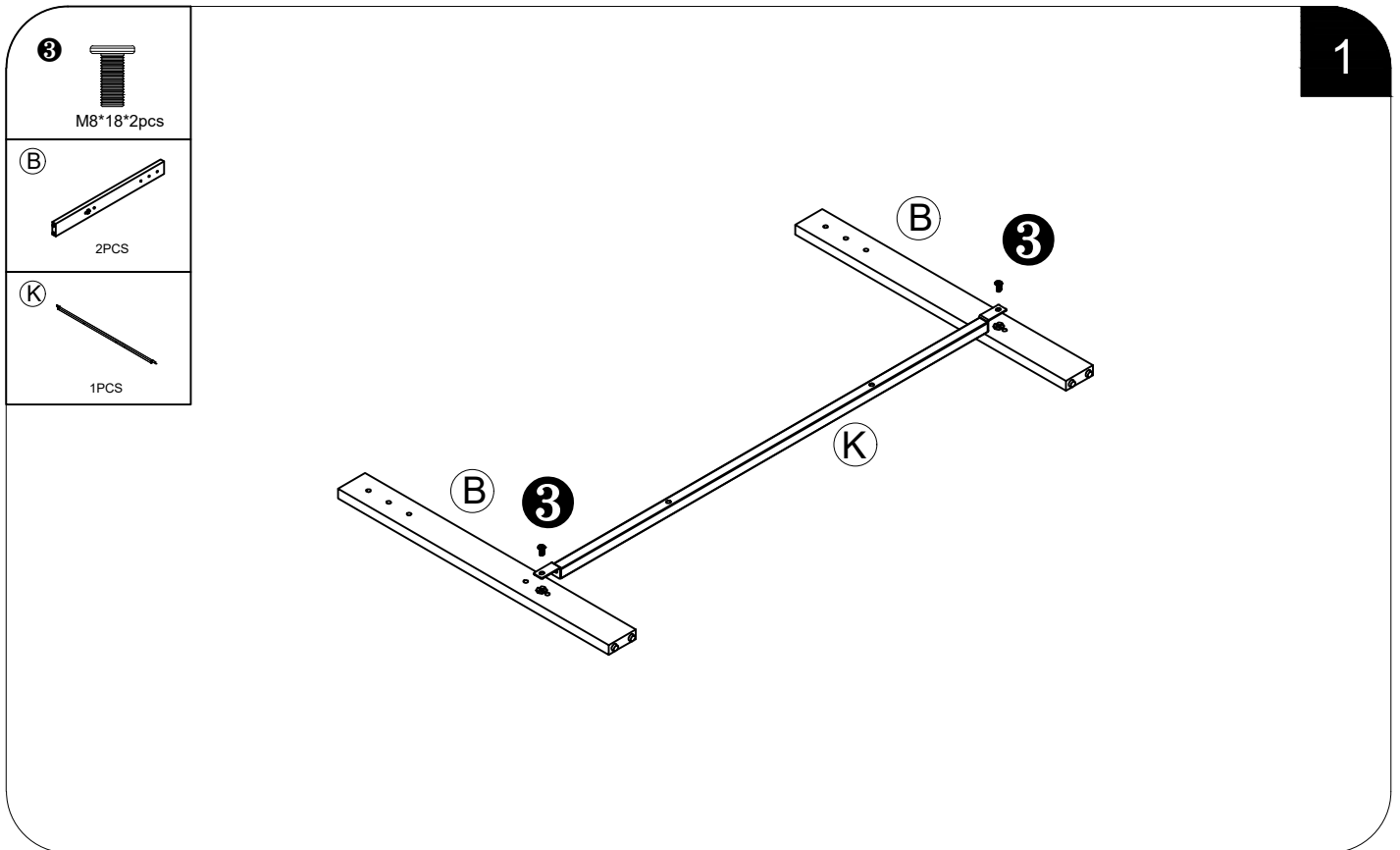

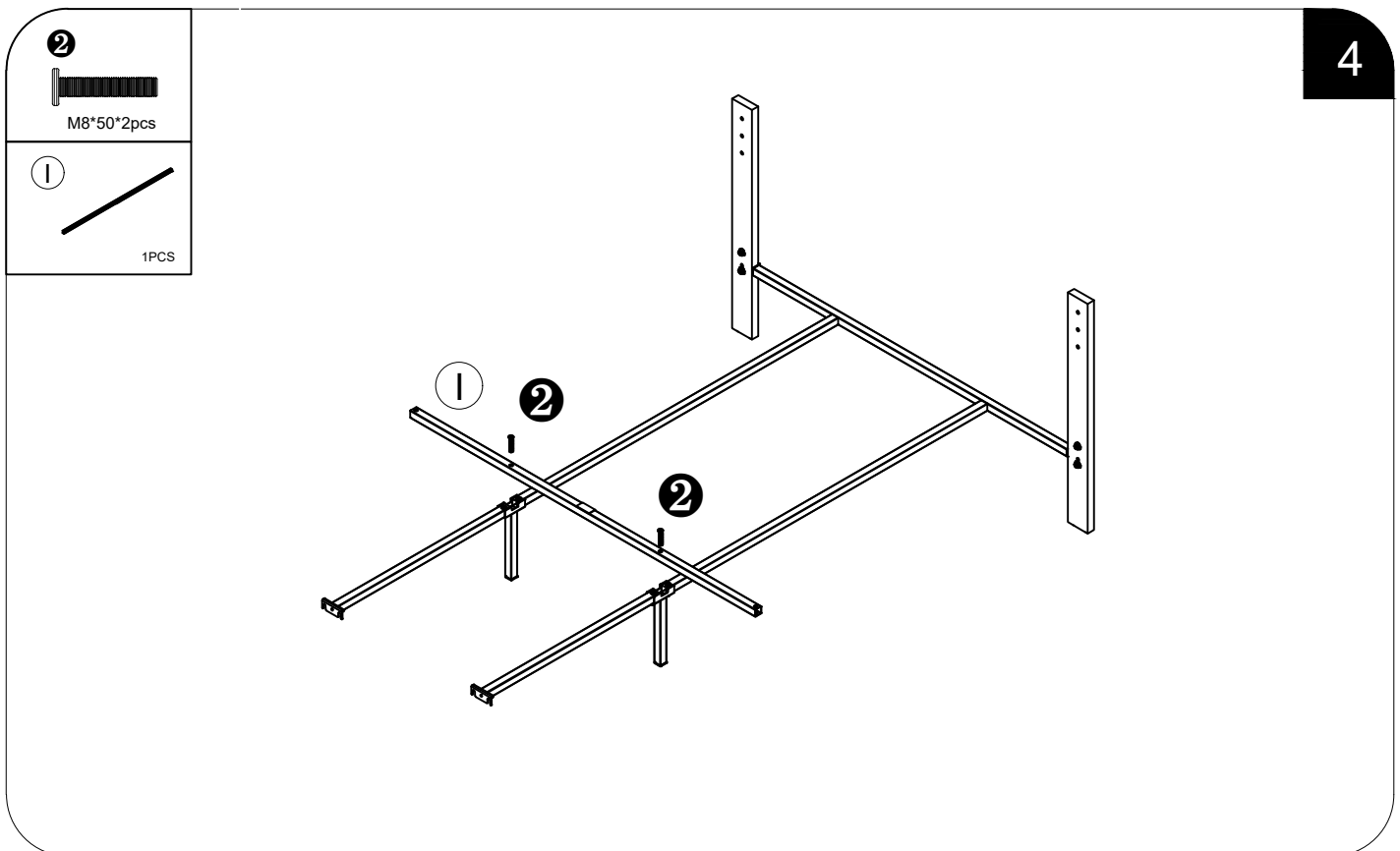
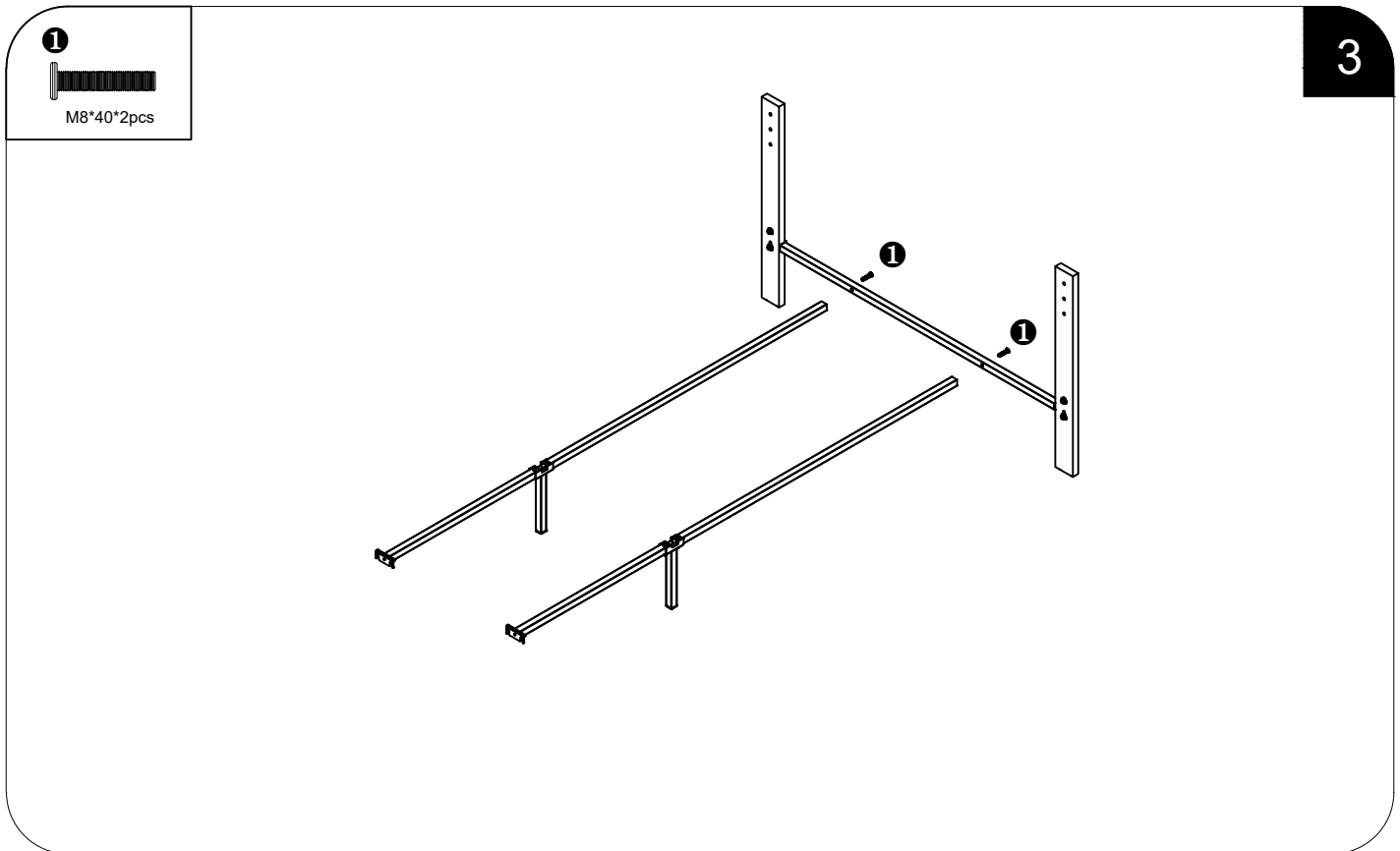

5

P
4PCS

H
2PCS

C3
1PCS

C4
1PCS

C1
1PCS

C2
1PCS

Schraube lösen, P einhängen und wieder festziehen.
Desserrez la vis, suspendez P et resserrez.

Schraube lösen, P einhängen und wieder festziehen.
Desserrez la vis, suspendez P et resserrez.

6

1
M8*40*2pcs

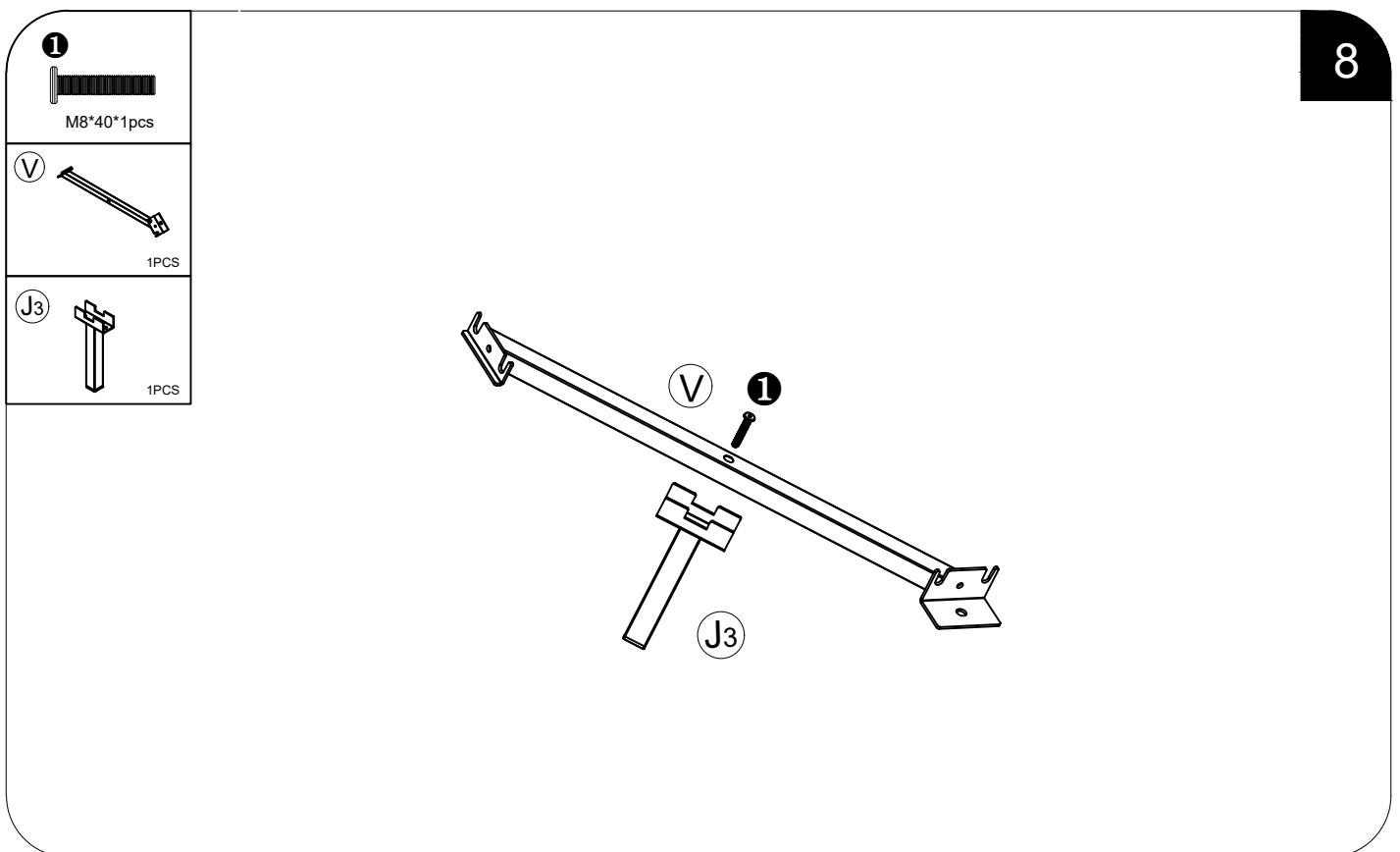
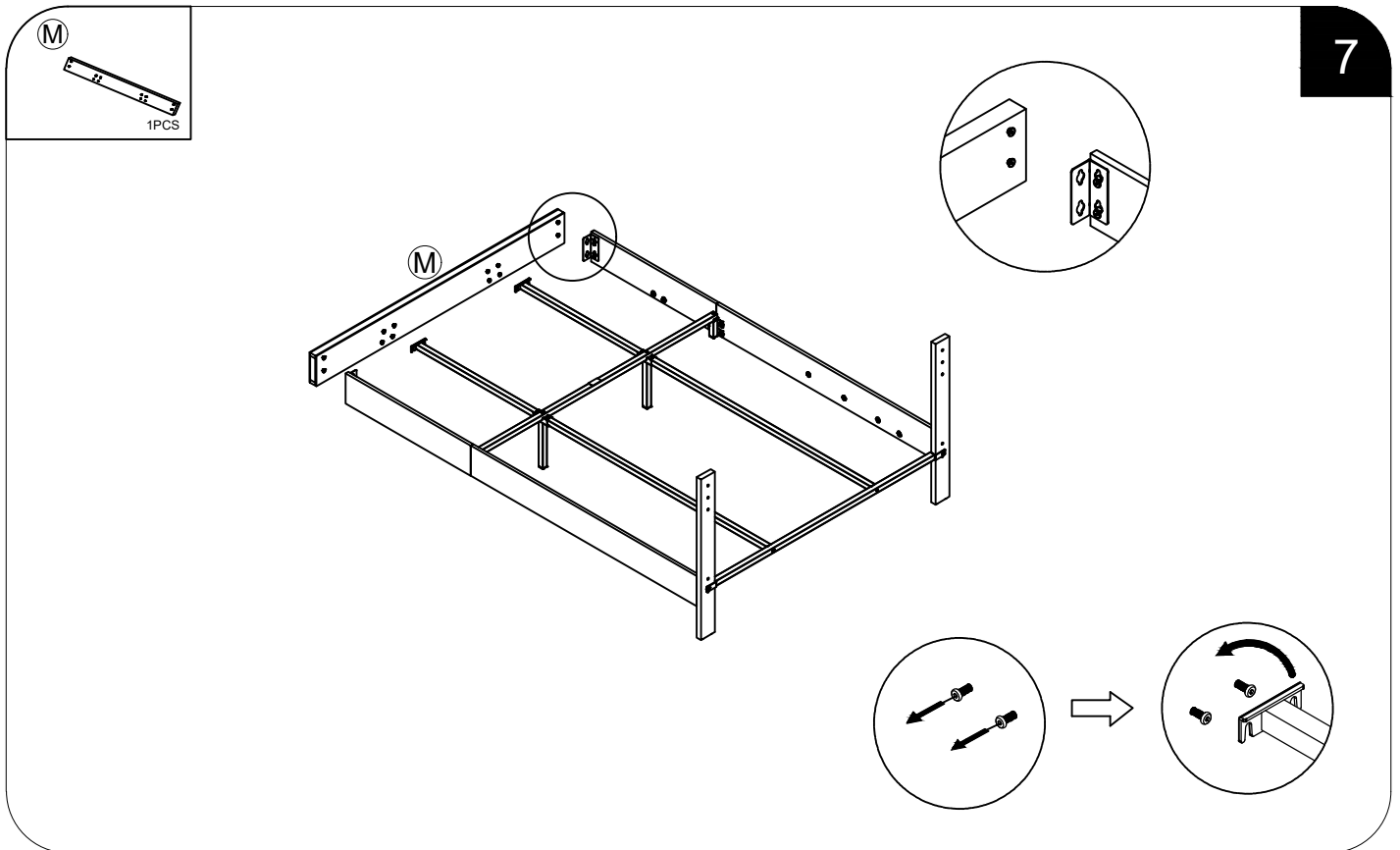

9

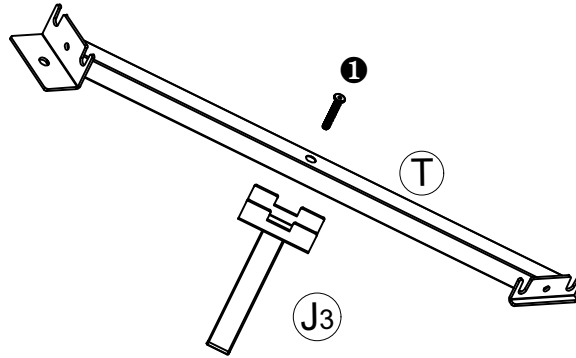
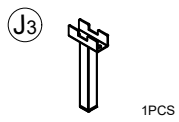
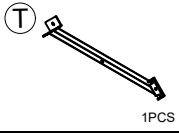
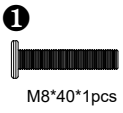

10

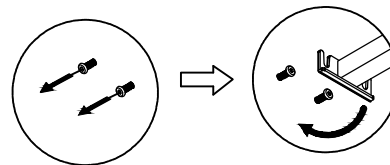
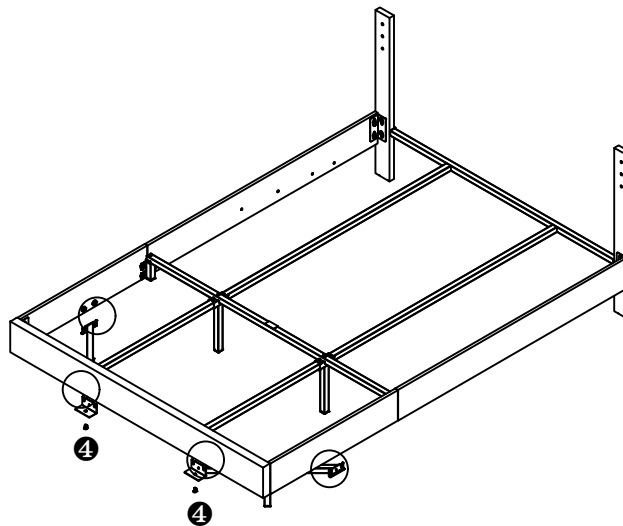
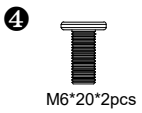

11

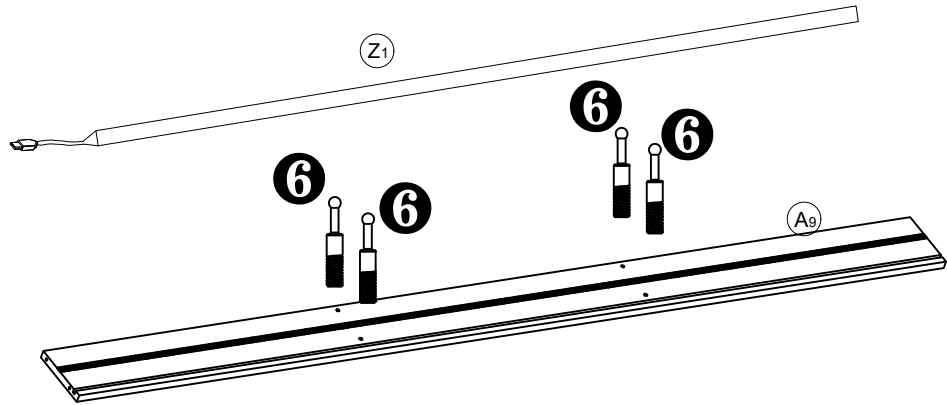
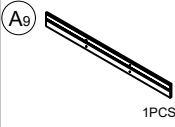
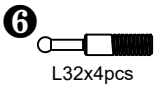

12

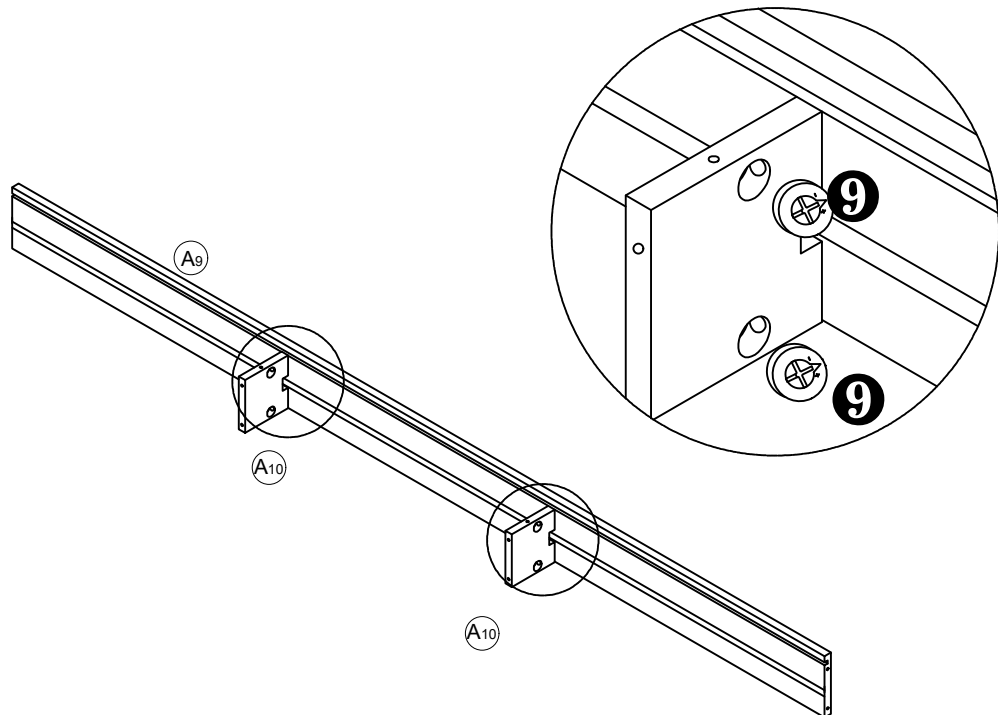
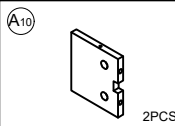

13

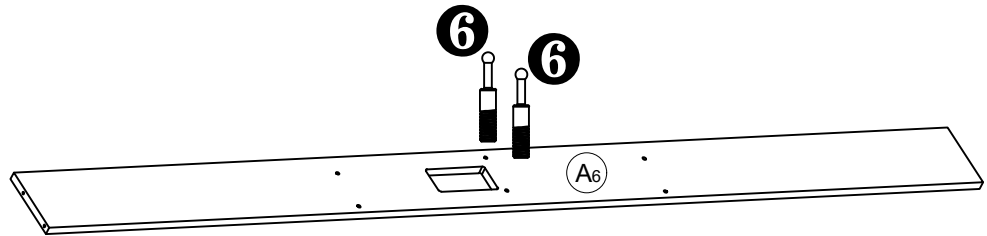
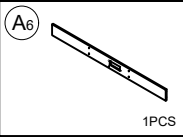
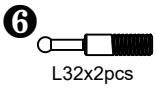

14

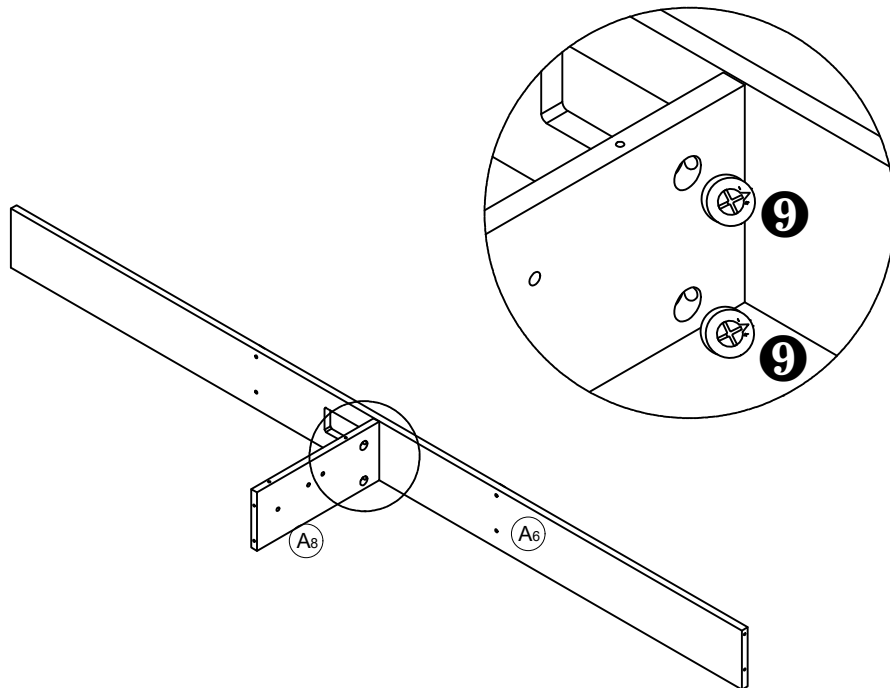
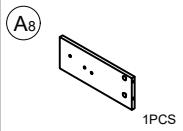

8

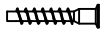

M5*30x4pcs

15

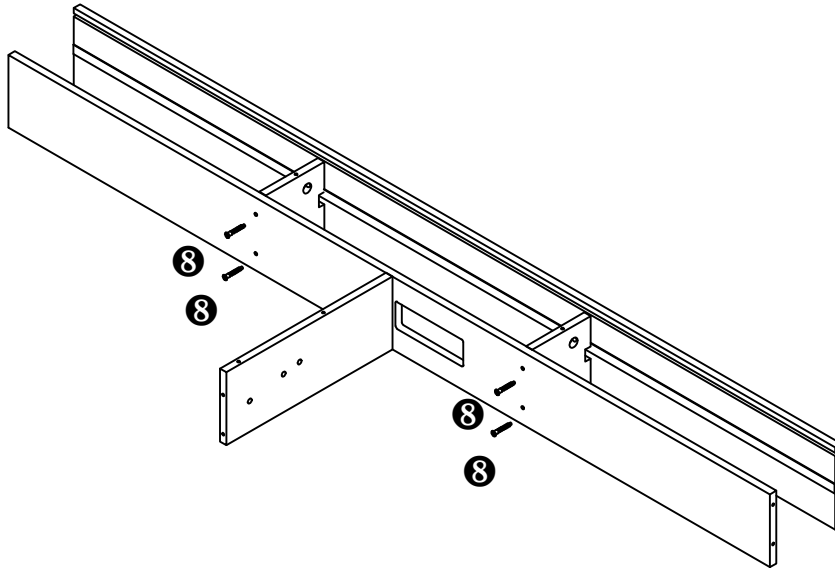

8

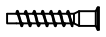

M5*30x8pcs

A2



1PCS

A3



1PCS

16

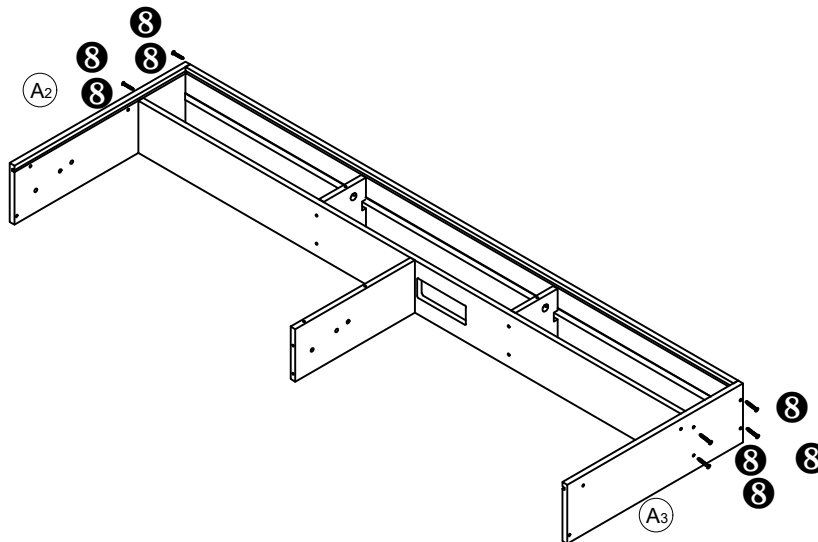

17

8

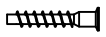

M5*30x10pcs

A4

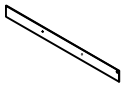

1PCS

A5

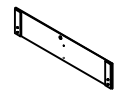

1PCS

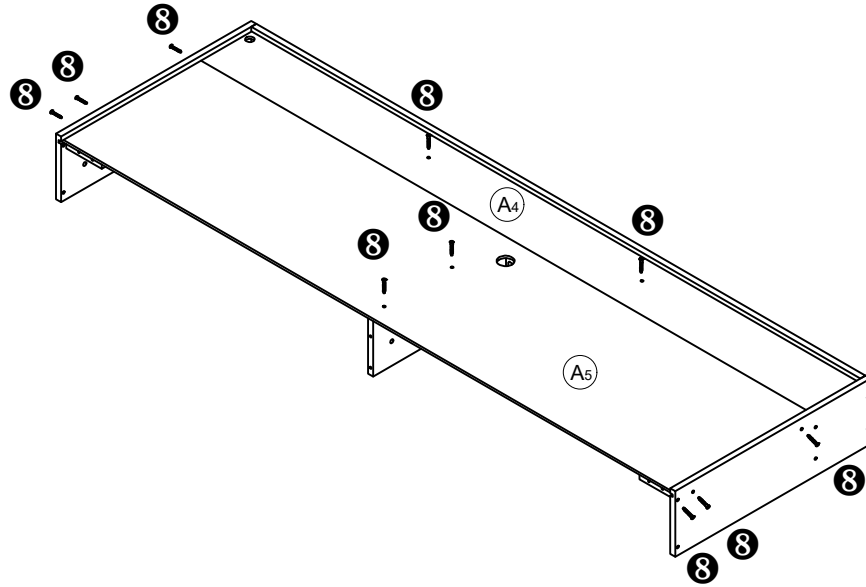

18

8

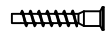

M5*30x6pcs

A7



1PCS

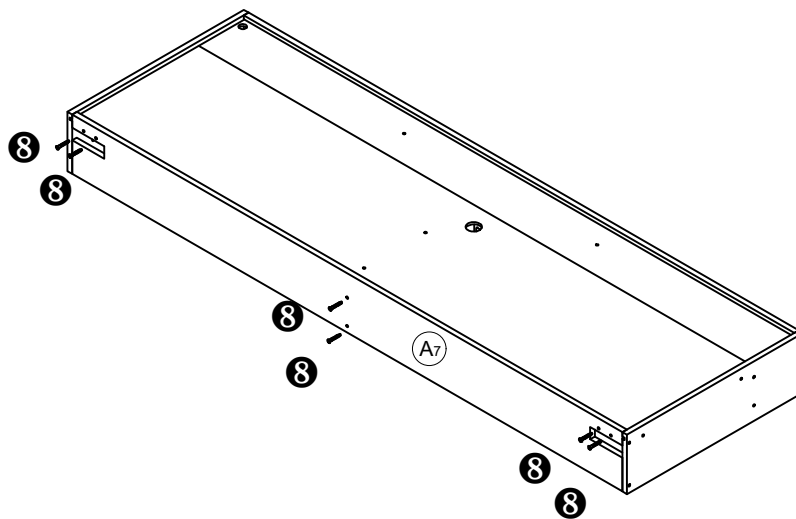

19

1



M8*40*4pcs

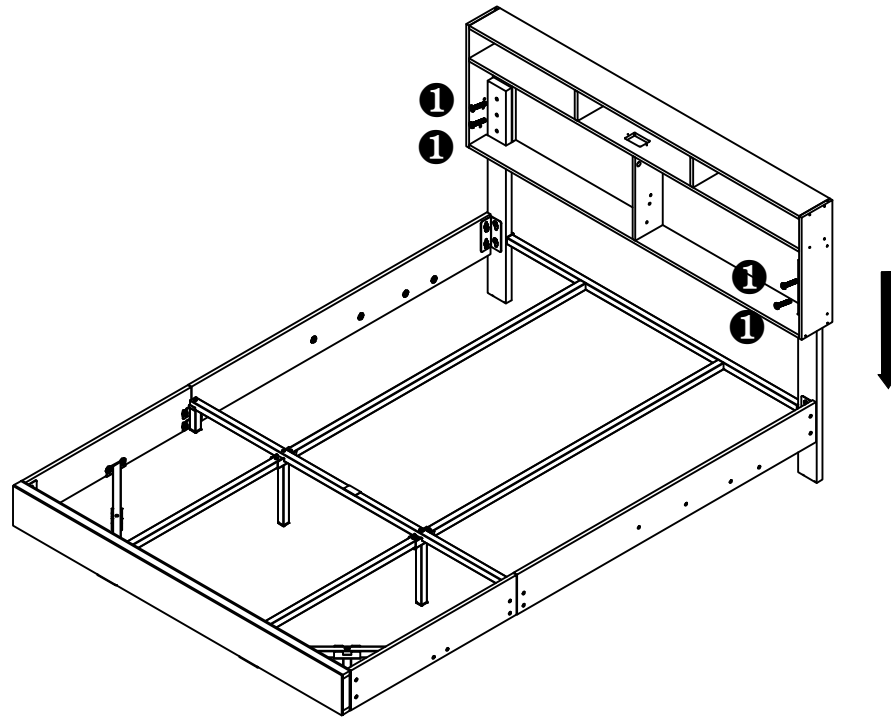

20

7



Ø3*10x2pcs

U



1PCS

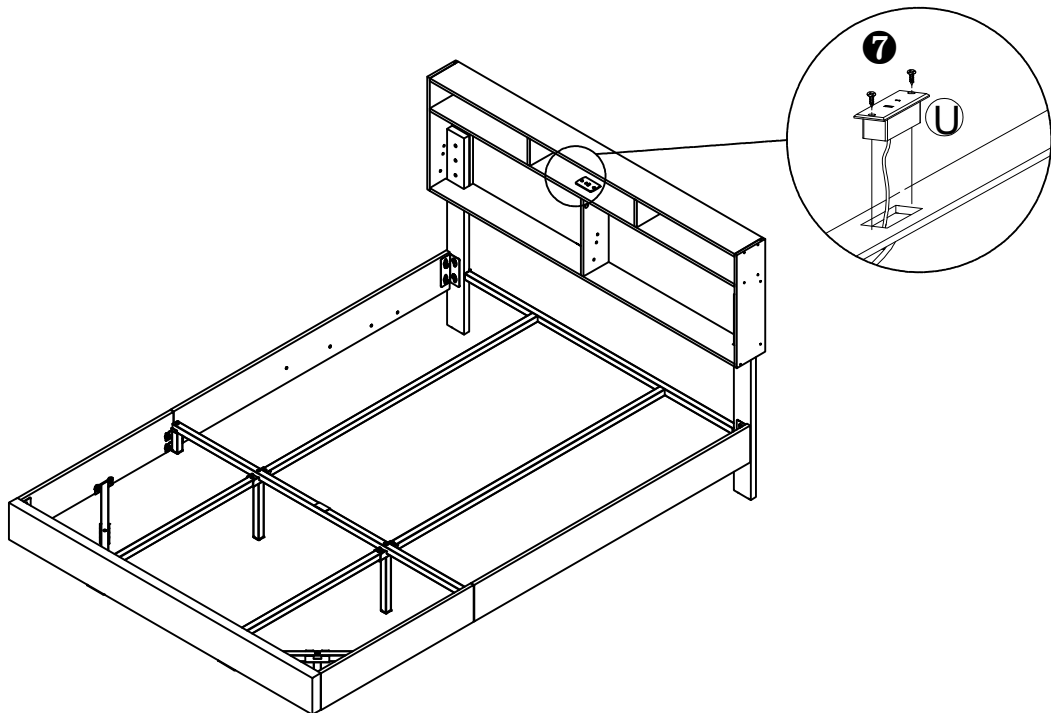



M4*12x9pcs

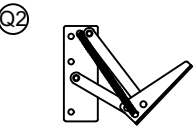
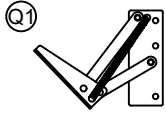

1. Das mittlere Zubehör kann für Q1 oder Q2 zufällig ausgewählt werden.
2. Wenn wir den Teil von Q1 angeben, installieren Sie die mittlere vertikale Platte auf der linken Seite.
3. Wenn wir den Teil von Q2 angeben, installieren Sie die mittlere vertikale Platte auf der rechten Seite.

1. Les accessoires du milieu peuvent être aléatoires pour Q1 ou Q2.
2. Si nous donnons la pièce de Q1, installez la plaque verticale centrale sur le côté gauche.
3. Si nous donnons la pièce de Q2, installez la plaque verticale centrale sur le côté droit.

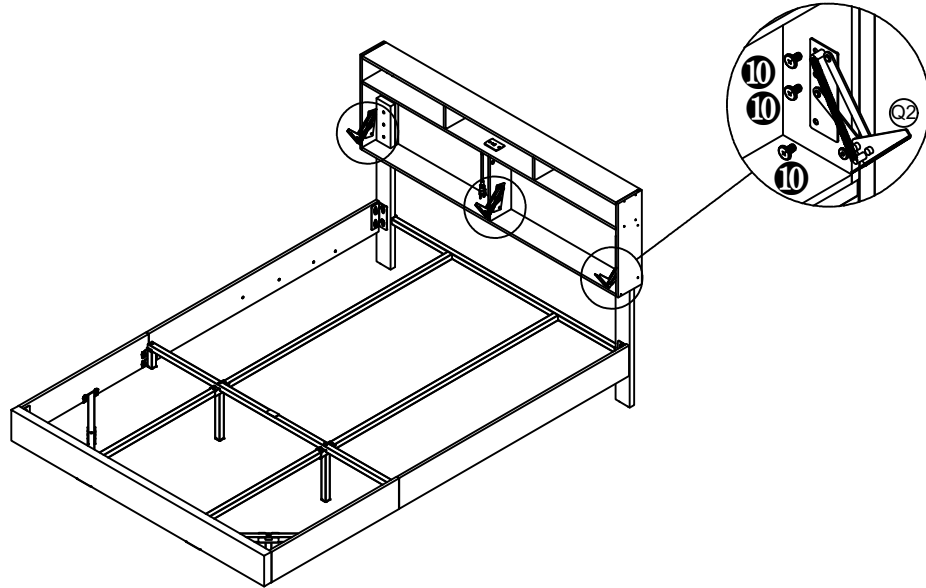

M8*18*12pcs

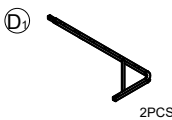

2PCS

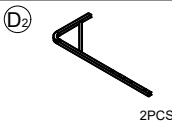



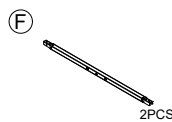

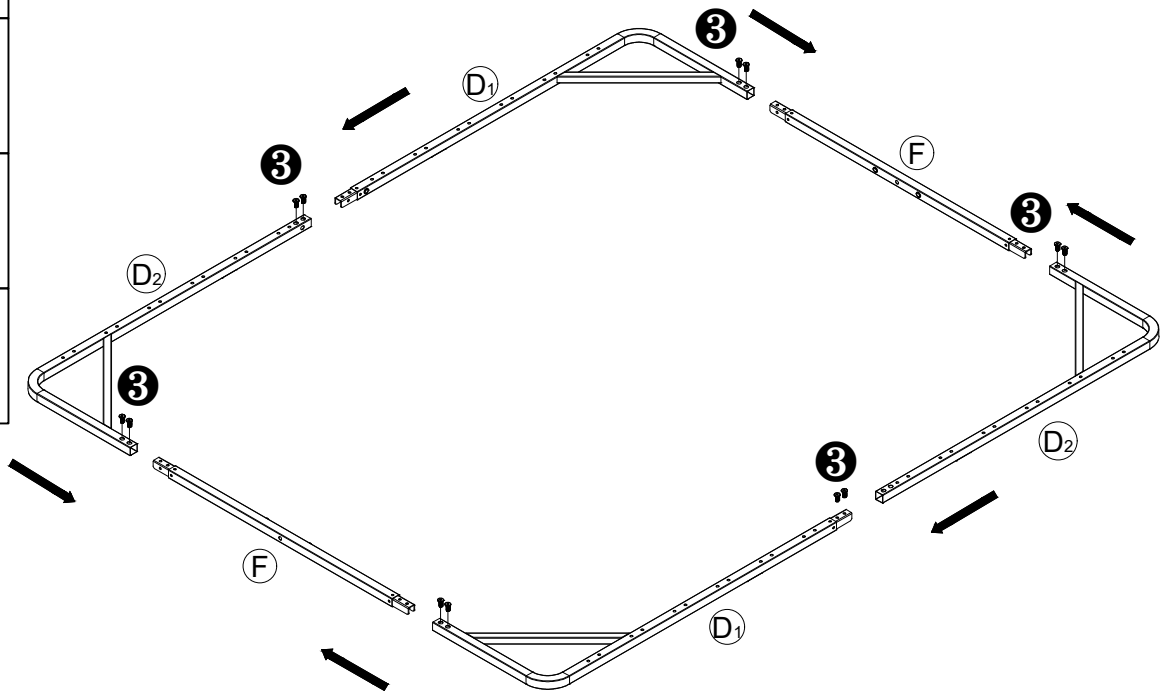

2PCS



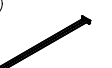
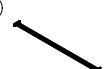

2PCS

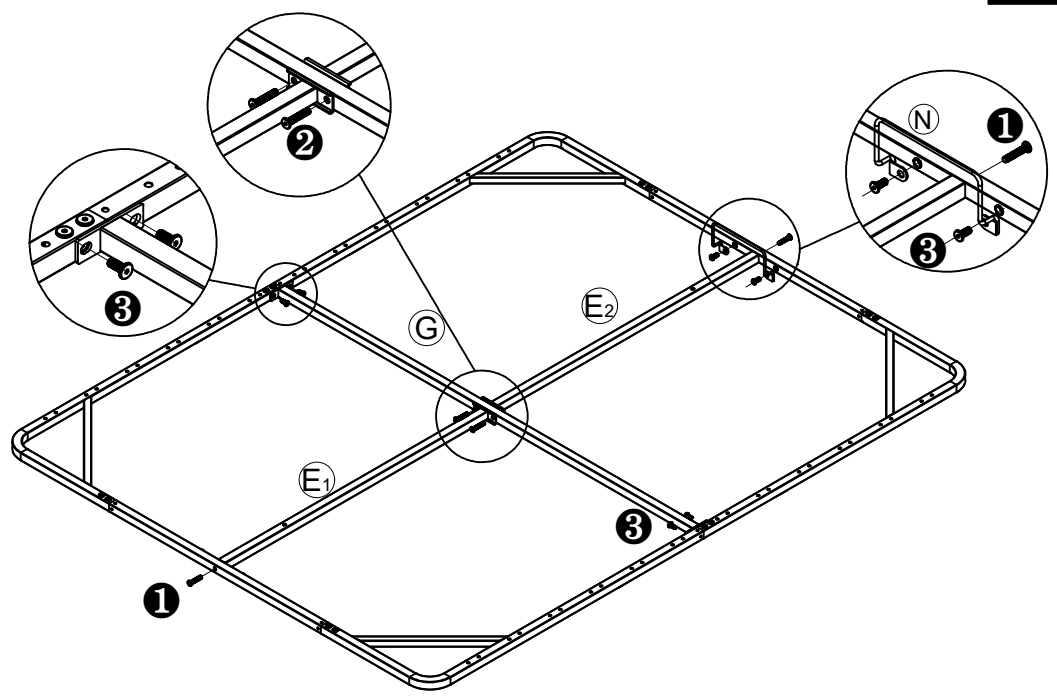

- 1**  M8*40*2pcs
- 2**  M8*50*2pcs
- 3**  M8*18*6pcs
- E₁**  1PCS
- E₂**  1PCS
- G**  1PCS
- N**  1PCS



- 3**  M8*18*8pcs
- L₂**  1PCS
- L₁**  1PCS

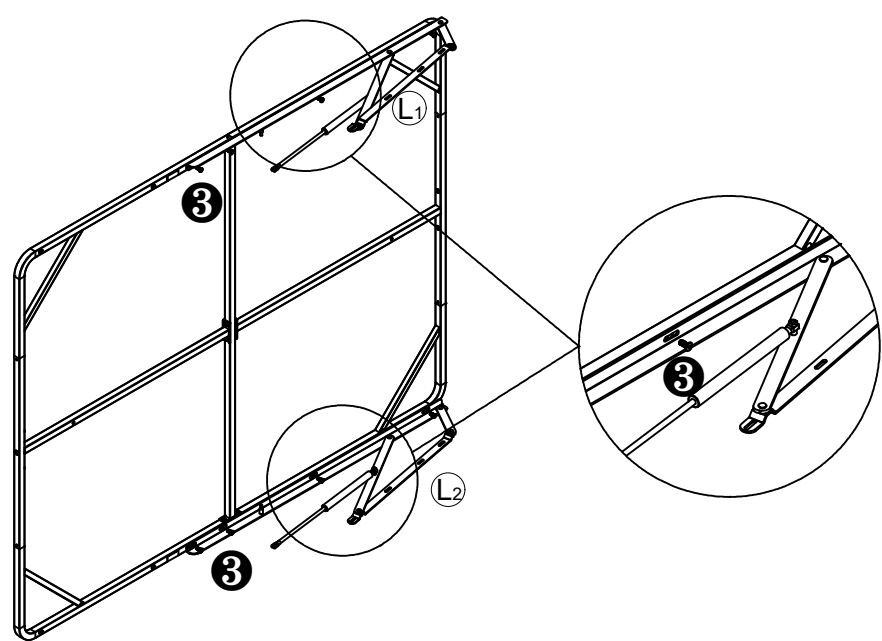

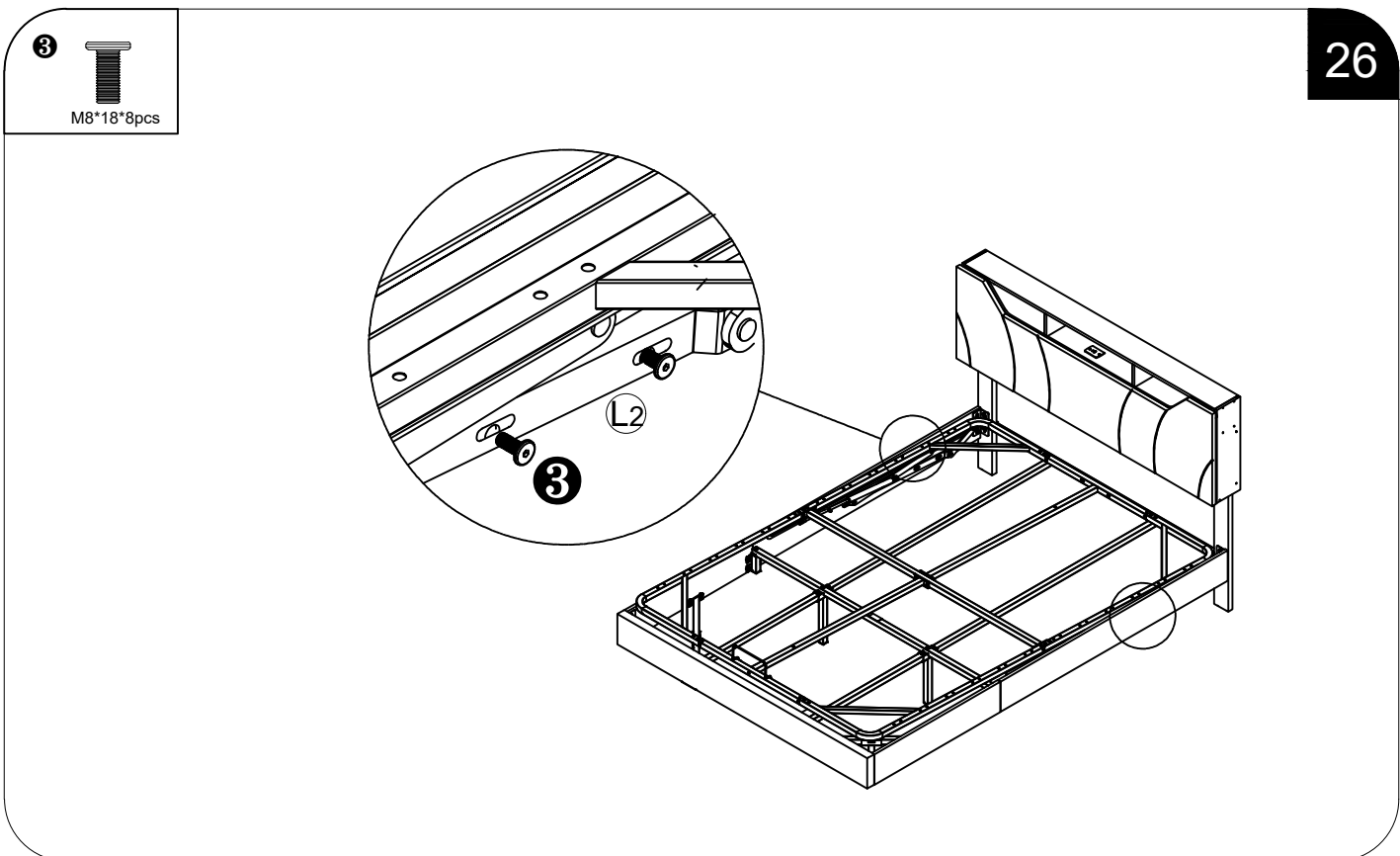
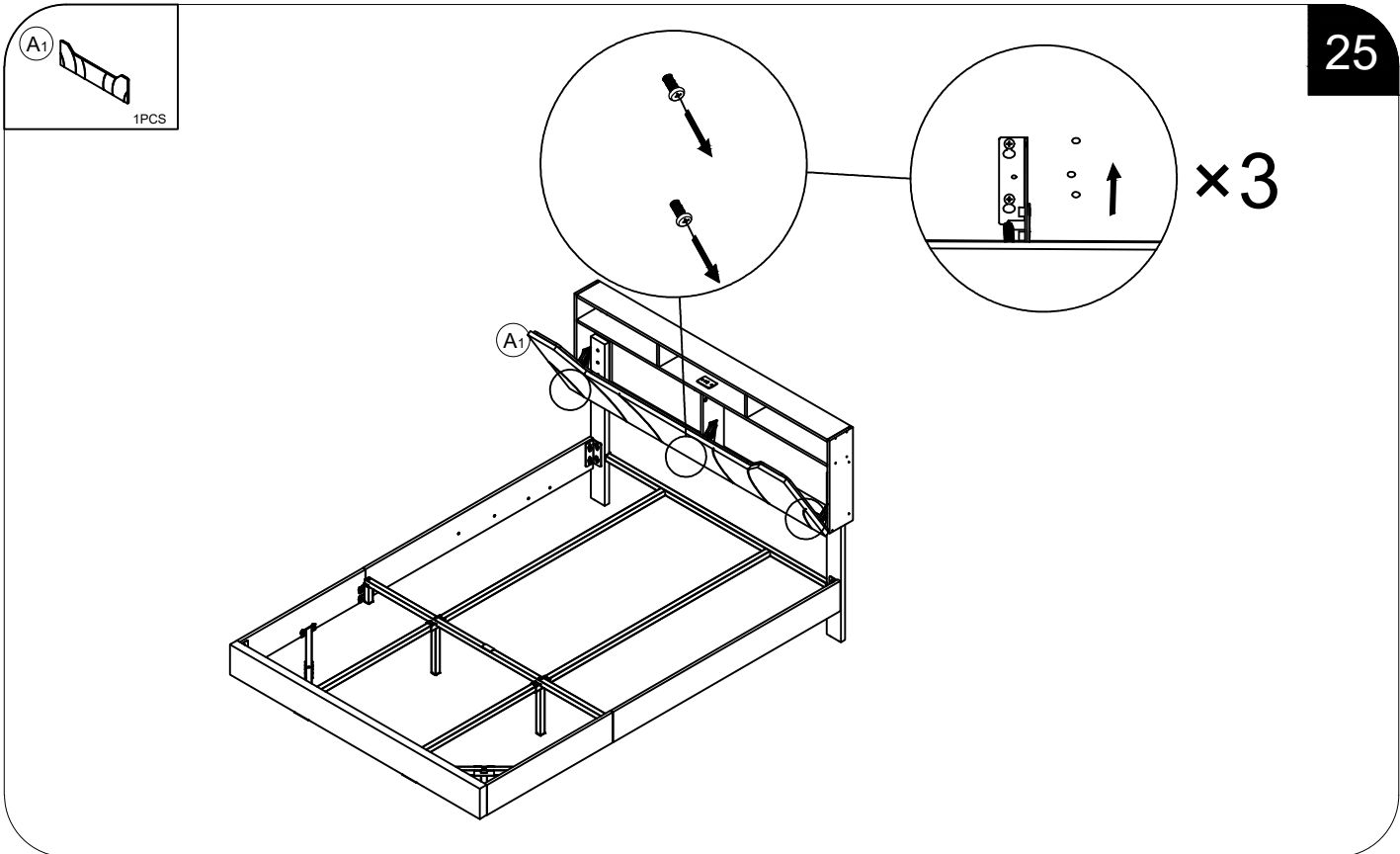

27

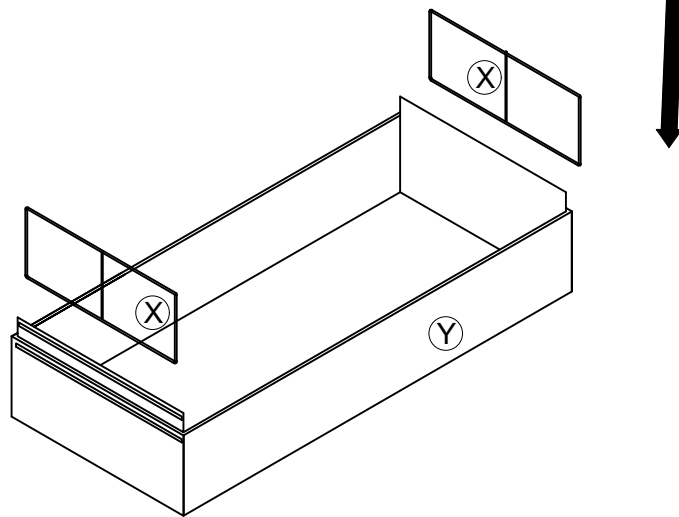
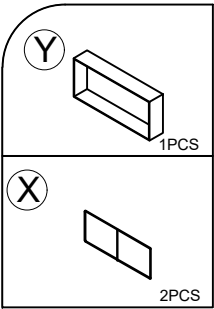

28

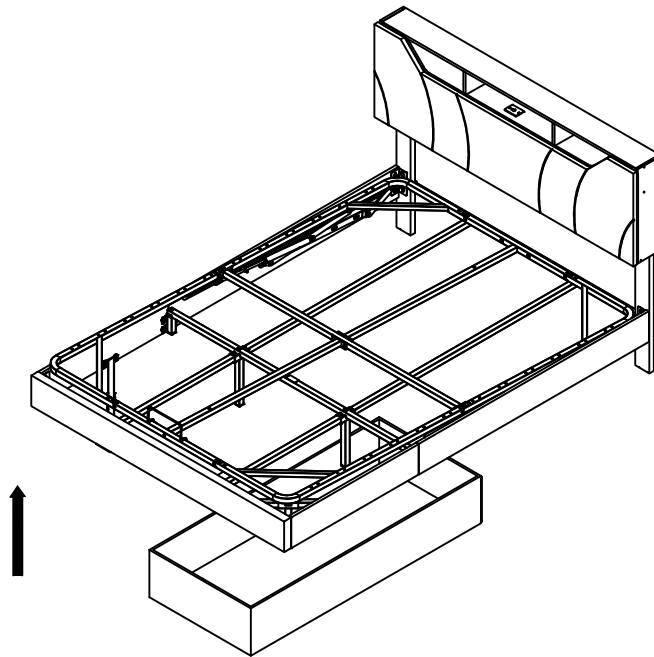

29

5
M8x2pcs

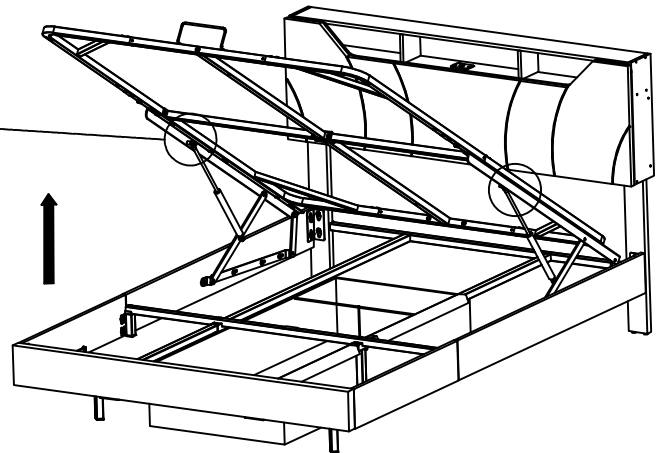
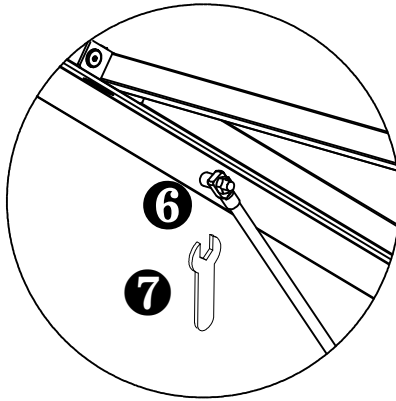

1
M8*40*1pcs

J1
1PCS

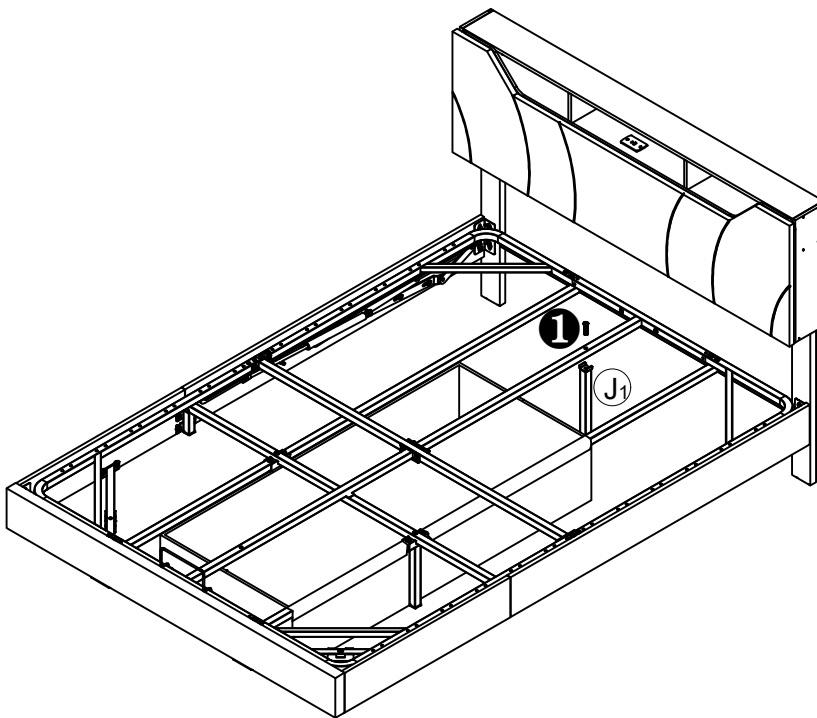

30

