

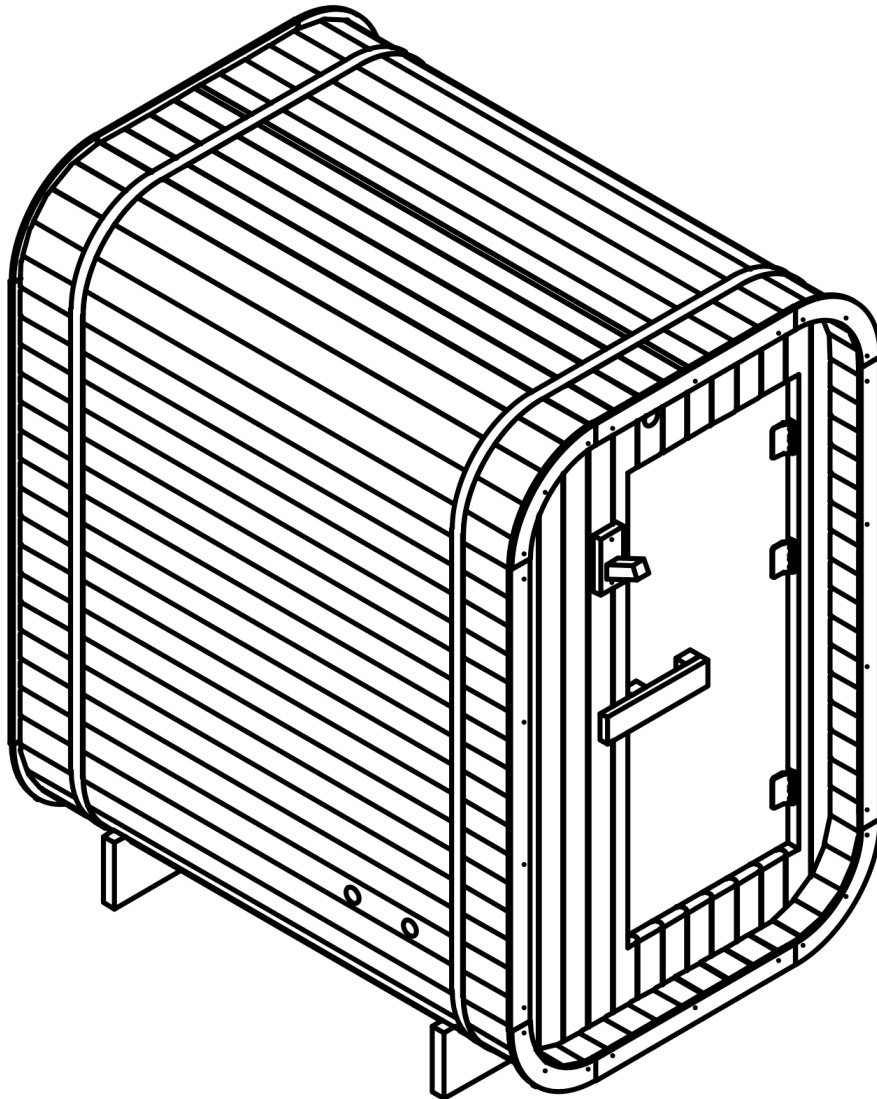

REDWOOD
OUTDOORS

Thermowood Mini-Cube Sauna



(SN-C-T2)
(SN-QBU-H2K001F)

Installation & Owner's Manual



Important Information

Safety and Assembly

Please read and understand the complete instructions prior to assembly and use of your sauna. The customer agrees not to hold Redwood Outdoors or any of its authorized dealers liable for improper installation, maintenance, and repair of this product.

Our sauna kits are designed for ease of assembly and every attempt has been made to make assembly information as clear as possible. If you have any questions about assembly, please do not hesitate to call us at 1800-567-8036 or send us an email at support@redwoodoutdoors.com.

Thank you again for choosing Redwood Outdoors. We are grateful for your business and know you will have many years of enjoyment in your sauna!

Electrical Requirements

All electrical heater wiring must be performed by **A QUALIFIED LICENSED ELECTRICIAN**. Use copper wire with 90C insulation. Do not use aluminum wire to make the connection. Consult with an electrician so you can determine the requirements for your situation. All wiring must conform to all national, state, and local codes and regulations. For further information and instructions on your heater installation and operation, please consult the heater manuals on our website. (www.redwoodoutdoors.com/assembly/electric-sauna-heaters).

Choose a Site With a Strong and Level Foundation

It is important to choose a site that has a level, strong, and stable foundation. This is critical because a sauna with several bathers inside can weigh over 1,000 lbs. A deck or concrete pad (patio) are both excellent options for your sauna. If you will be placing the sauna directly on the ground, we recommend you rest the support cradles atop concrete pavers to prevent the cradles from settling into the ground. This could result in the sauna not sitting level and may cause issues over time. If your sauna comes with a ground-frame rather than cradles, we recommend installing a moisture barrier under the ground-frame.

Concrete Pads

If constructed properly (compacted well and leveled), a concrete pad will maximize the life of your sauna. The concrete pad should be at least 4" thick and reinforced with mesh to minimize cracking. We recommend constructing the pad significantly larger than needed for the sauna alone, as this will allow room for a cool down area, where you could put chairs and an outdoor shower or cold plunge tub. There is a wealth of information available online with instructions on how to design and pour a concrete pad.

Deck Installations

If you choose to install your sauna on a deck, be sure that your deck has been designed to support the weight of a full sauna (over 1,000 lbs). We recommend you have the deck inspected by a qualified architect or building engineer prior to proceeding.



REDWOOD
OUTDOORS

Installation & Owner's Manual

CONTENTS









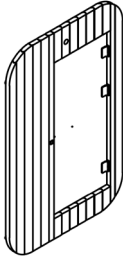

Parts List	02
Dimensions	04
Base Assembly	05
Wall Assembly	07
Body Assembly	08
Interior Assembly	11
Exterior Finishing	16
Heater Installation	17
Interior Finishing	19
Shingle Assembly	20
Maintenance	24
Maintenance and Warranty	25
User Guide	26
Important Notice	28

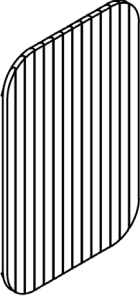
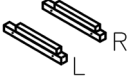
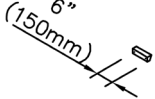
Parts List

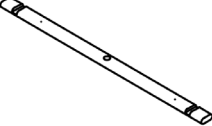

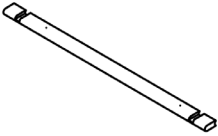

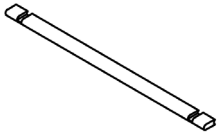
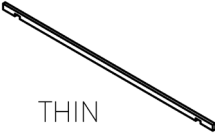
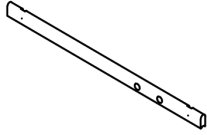
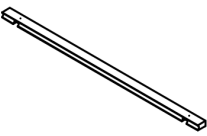
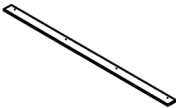
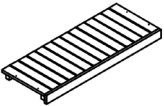

We are constantly working to improve our products. As a result of ongoing design improvement, the sauna you receive may vary slightly from the description below. + symbol indicates spare pieces. (e.g. +1 means 1 spare)

When you open the crate, if any parts are damaged, take pictures of the damage (ideally while still in the crate). Email the pictures as well as a list of which parts are damaged (e.g., 2-B, 18, etc.) to our Customer Support team (support@redwoodoutdoors.com). Our Customer Service team will assist you with next steps.

















● Main Parts

Part	Description	Qty	Part	Description	Qty
1-B		1PC	9		1PC
			10	Intentionally blank	
			11		1PC
2		1PC	12		2PCS
			13		2PCS
			14-A		1PC
3-A		1PC	15		2PCS
4		12PCS	16		1PC
5		51PCS	17		1PC
6		1PC	18	Intentionally blank	
			19	Intentionally blank	
7		2PCS	20	Intentionally blank	
			21		4PCS
8		1PC	22		4PCS



Part	Description	Qty	Part	Description	Qty
23		8PCS	26		1PC
24		1PC	27		2PCS
25-A		1PC	28-A		1PC

● Accessories

Part	Description	Qty	Part	Description	Qty
A	 #8x1" (4x30mm)	52PCS	K	 $\Phi \frac{3}{4}$ "x1 $\frac{1}{2}$ " (Φ 20x40mm)	4PCS
B	 #8x $\frac{3}{4}$ " (4x20mm)	50PCS	L	 $\frac{3}{8}$ " (M10)	4PCS
C	 #8x1 $\frac{1}{2}$ " (4x40mm)	130PCS+5	M	 $\frac{3}{8}$ " (M10)	4PCS
D	Intentionally blank		N	 $\frac{3}{8}$ " (M10)	4PCS
E	 #8x2 $\frac{1}{2}$ " (4x60mm)	4PCS	O	Intentionally blank	
			P	Intentionally blank	
F	 #10x2 $\frac{3}{4}$ " (5x70mm)	39PCS	Q		1PC
G	 #12x3" (6x80mm)	2PCS	R		1BAG
H		2PCS	S	 46 $\frac{1}{2}$ "x39 $\frac{3}{8}$ " (1180x1000mm)	2PCS
I	 $\frac{3}{8}$ "x13" (M10x330mm)	2PCS	T	 80 $\frac{1}{4}$ "x68 $\frac{1}{8}$ " (2040x1730mm)	1PC
J	 Φ 1 $\frac{3}{8}$ "x1 $\frac{1}{2}$ " (Φ 35x40mm)	4PCS			

Dimensions

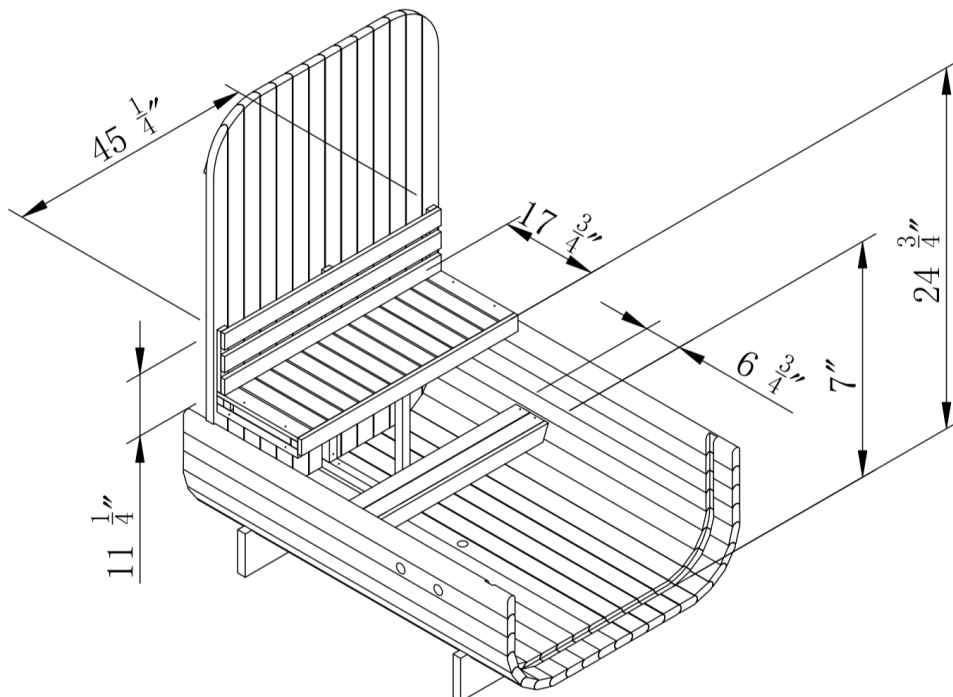
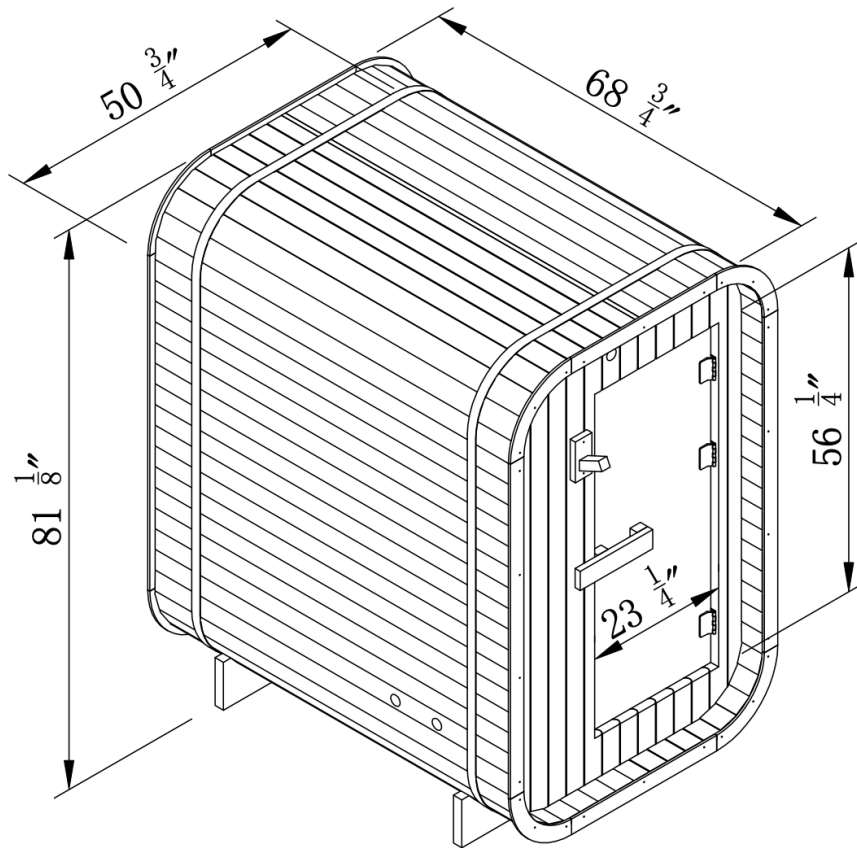

Base Assembly

Step 1: Assemble the Base

Lay your cradles on the foundation. The wooden cradles are painted black to provide additional protection against water.

Ensure the cradles are level. The cradles must be evenly spaced and parallel. Make sure the cradles are parallel by measuring from corner to corner.

Lay the center stave across the center point of the cradles. The end of the stave should extend **9-1/8"** past the cradles on both edges. Measure to confirm the center stave is in the middle of the two cradles.

Fasten the center stave to the cradles.

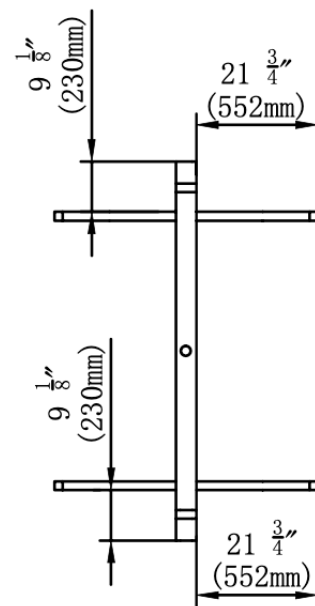
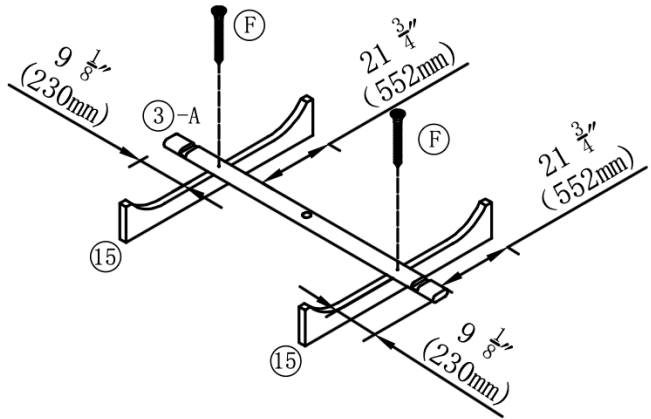



3-A	15	F
		#10x2 ³ / ₄ " (5x70mm)

Base Assembly

Step 2: Install the Base Staves

Fill the cradles to the edge with staves. As you lay the staves, tap them into place using a rubber mallet to ensure a snug fit. Ensure the groove cut (also called “dado cut”) for the front and back walls aligns and that the ends of the staves are flush. Fasten the rest of the base staves to the cradles.

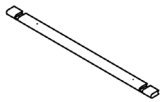
Reconfirm the cradles are level and parallel. Make sure the cradles are parallel by measuring from corner to corner.

4	F
	 #10x2 $\frac{3}{4}$ " (5x70mm)

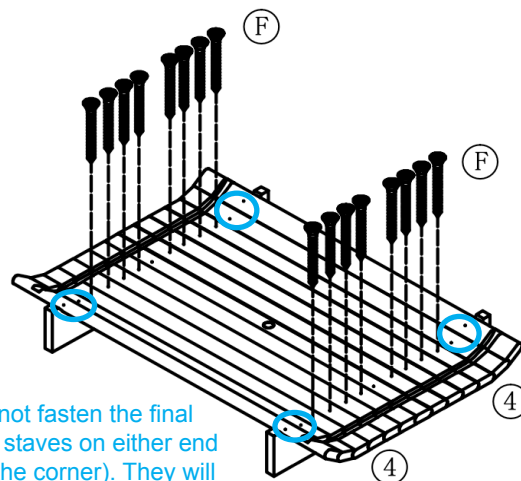





Do not fasten the final two staves on either end (in the corner). They will be fastened after the bands are installed (see Step 8)

Wall Assembly

Step 3: Install the Front Door Handle

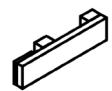
Place the two door handle pieces on either side of the glass door. The pieces should align with the pre-cut holes in the glass door. Fasten the two pieces together (the screw should pass through the glass door to prevent the handles from moving).

7	24	25-A	G
			 #12x3" (6x80mm)

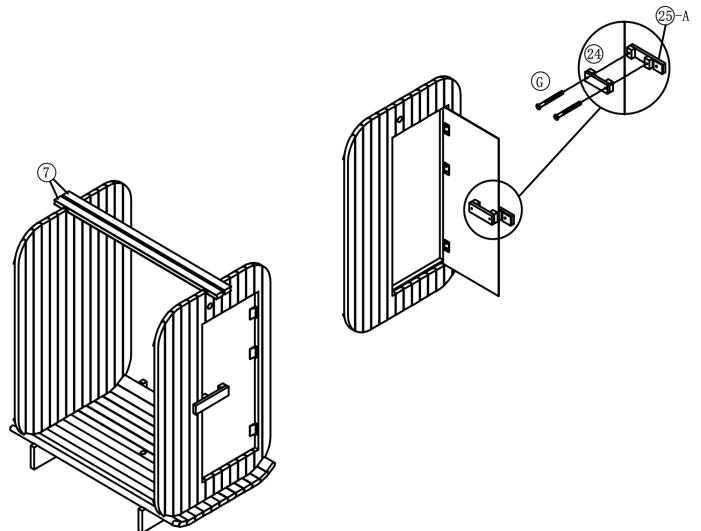

Step 4: Place the Walls on the Base

Fit the front and back walls into the dado cuts. Use a level to confirm that the walls are level with the ground.

We recommend placing one stave across the top of the walls to prevent movement as you build up the side walls.

The vent hole should be at the top of the front wall.

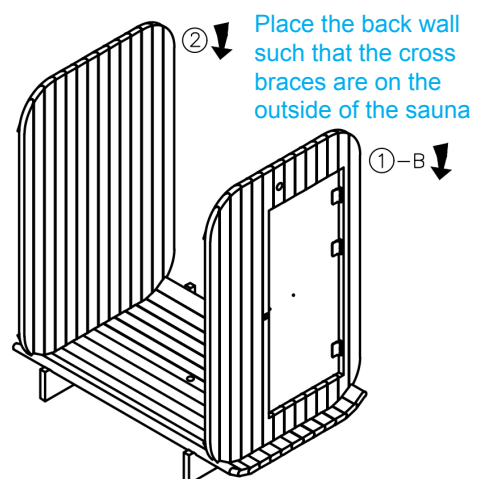
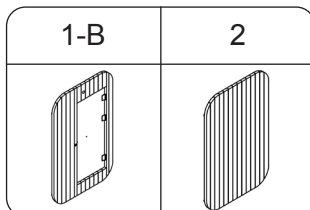



Body Assembly

Step 5: Install the Wall Staves

Build up the staves on both sides of the wall. Each stave must be fastened at both ends with screws.

Tap each stave into place using a rubber mallet to ensure a snug fit. **Make sure the staves are parallel with the ground before fastening them to the sauna walls.** If staves are skewed, you may have difficulties rounding the corners at the top and closing the gap in the roof.

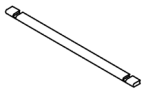
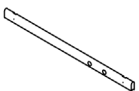
Handle the staves with care. The wood is kiln-dried and brittle. If staves are dropped or mishandled, they can crack or even break.

5	6	C
		
		#8x1½" (4x40mm)

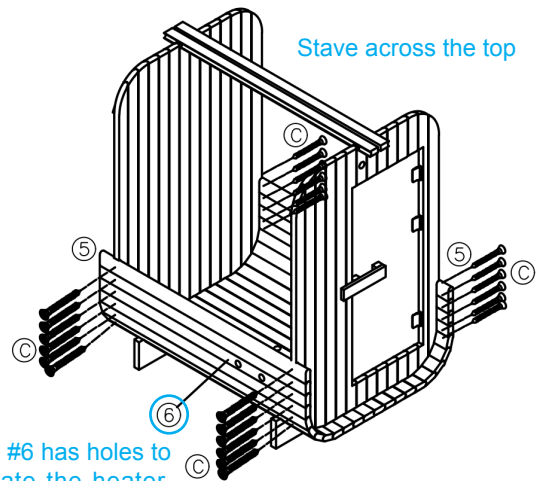

Stave #6 has holes to ventilate the heater. Place it on the left side of the sauna 2-3 staves from the bottom

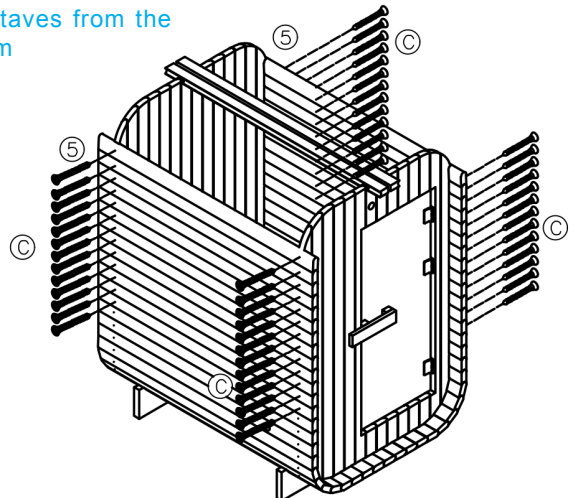

Step 6: Complete the Roof

When you reach the corners, **only fasten the screws to ~50% depth.** Leave the head of the screw out to allow for movement at the corners while the roof boards are placed.

Place all roof staves before fastening any with screws. This will allow the staves space to move while completing the roof.

The final staves installed are the two top staves. The flat sides should face each other at approximately the top center of the sauna. If there is a gap, add the spacer stave (stave with double flat edges).

If the spacer stave is not needed, store this stave as it may be needed later. Over time the wood can dry and shrink slightly, this spacer stave can be used to close any gaps that may appear.



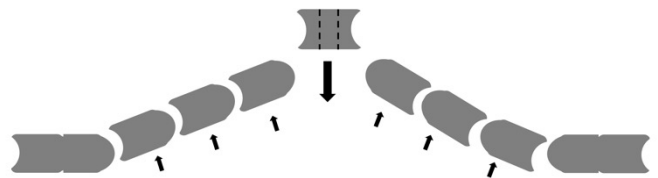
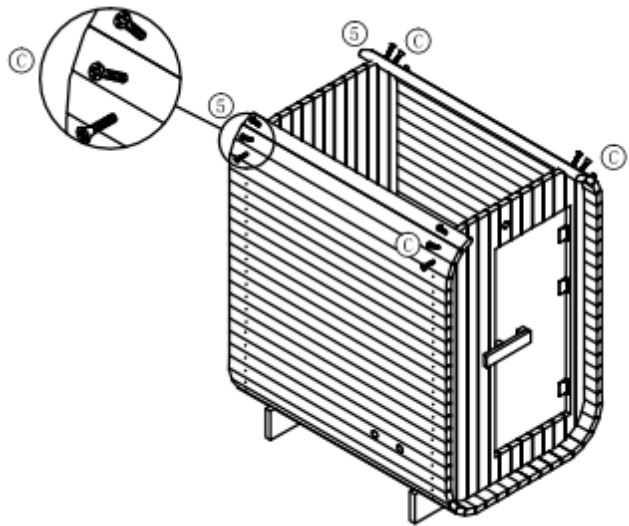

Once all roof staves are in place, fasten them down to the sauna walls as was done with the wall staves.

Finally, fasten the corner stave screws down to 100% depth so that there is no screw head showing above the stave.

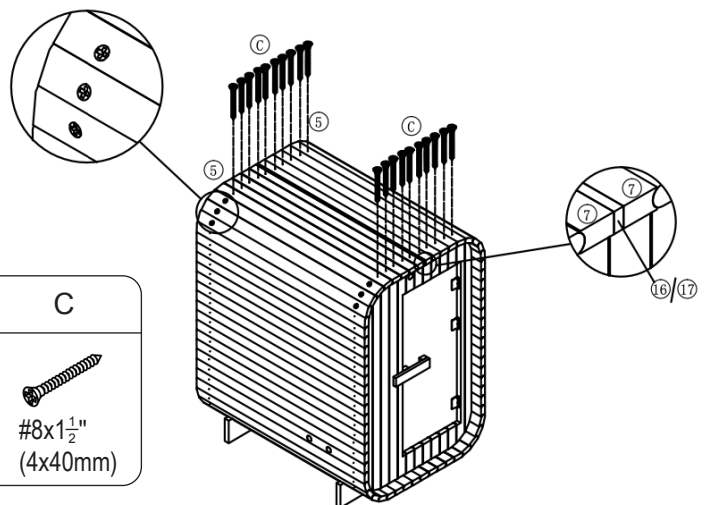

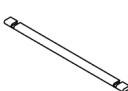
Bumping the staves nearest to the center outwards will increase the perimeter of your sauna. This will give you extra space to insert the final stave or spacer









5	7	16	17	C
				
		THICK	THIN	#8x1½" (4x40mm)

Body Assembly

Step 7: Install the Bands

Wrap the unit with the bands. Install the bands at the edges of the sauna close to the cradles as shown. Tighten the bands using two wrenches until tight.

H	I	J	K
			
	$\frac{3}{8}$ "x13" (M10x330mm)	$\Phi 1\frac{3}{8}$ "x1 $\frac{1}{2}$ " ($\Phi 35$ x40mm)	$\Phi \frac{3}{4}$ "x1 $\frac{1}{2}$ " ($\Phi 20$ x40mm)
L	M	N	
			
$\frac{3}{8}$ " (M10)	$\frac{3}{8}$ " (M10)	$\frac{3}{8}$ " (M10)	

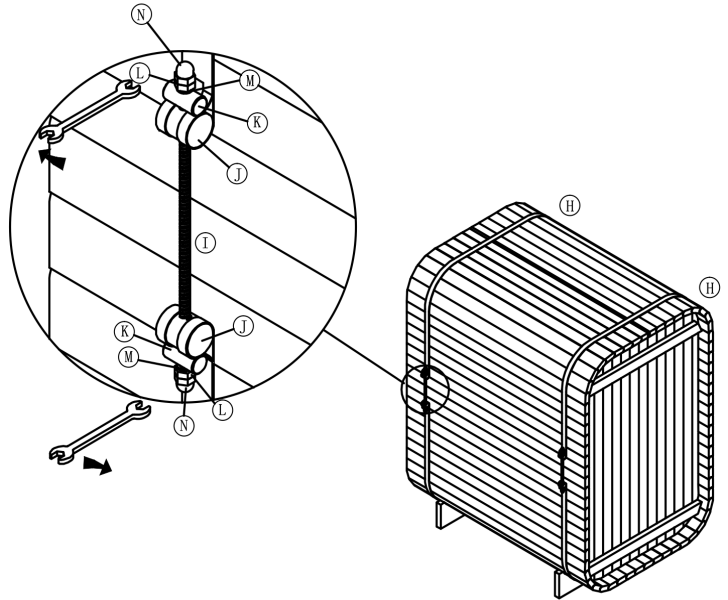

Step 8: Fasten the Corner Staves

Once the bands are tight, fasten both sides of the two lower corner staves to the cradles.

F

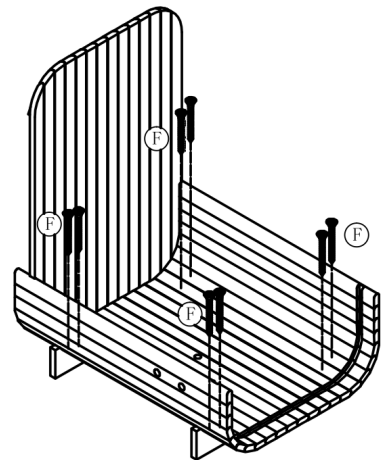
#10x2 $\frac{3}{4}$ " (5x70mm)





Interior Assembly

Step 9: Place the Bench Frame

Place the frame (#28) against the back wall. The bottom corner should be snug in the bottom corner of the sauna. The longer edge should be on the back wall and the shorter edge should be on the floor (the frame should be "tall").

The little square at the front of the frame should be in the middle of the sauna. This is the frame the footrest will sit on.

Fasten the frame to the back wall and floor following the pre-drilled hole pattern.

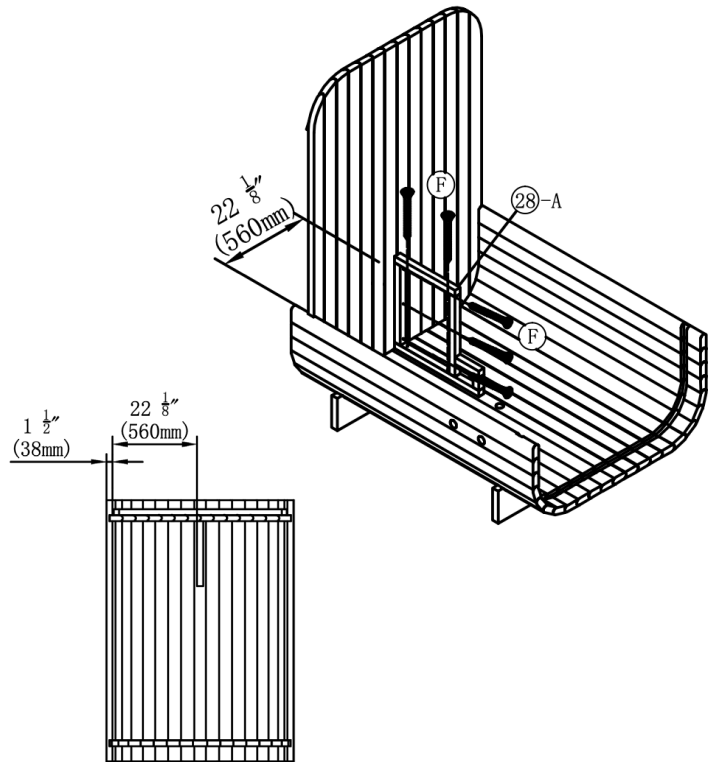

28-A	F
	
	#10x2 $\frac{3}{4}$ " (5x70mm)



Step 10: Place the Back Cleat

Place the long cleat (#11) on top of the frame so that it runs the length of the back wall.

Make sure the cleat is level and touching the bench frame, then fasten it to the back wall with screws.

11	F
	
	#10x2 $\frac{3}{4}$ " (5x70mm)

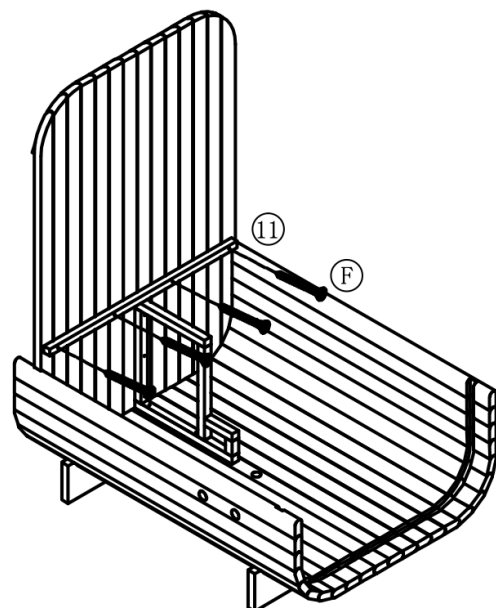



Interior Assembly

Step 11: Place the Side Cleats

Place the side cleats (#12) on the side wall underneath the back cleat. The cleats should touch and form a 90-degree angle.

The raised piece of the side cleat should be on top and create a channel for the bench to sit in.

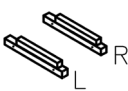
Make sure the left cleat is on the left side, and the right cleat is on the right side. Use the pre-drilled holes as a guide. The longer edge of the cleat should be under the back cleat touching the back wall.

12	F
	
	#10x2 $\frac{3}{4}$ " (5x70mm)

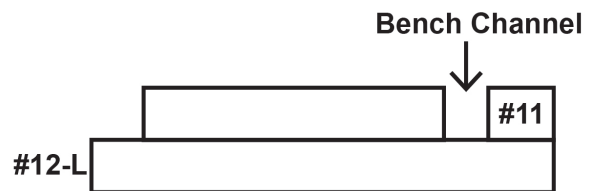
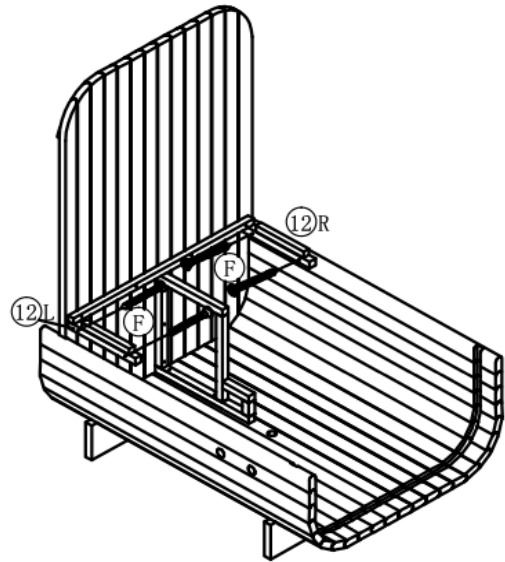

Step 12: Fasten the Footrest Cleats

Place the footrest across the sauna so that it sits on top of the footrest support.



Place a spirit level across the footrest board to confirm it is level.

Place the side cleats on the side wall underneath the footrest board on one side.

The cleats are cut at an angle. The angled side of the cleat should fit into the rounded groove of the sauna. The other end of the cleat should form a 90-degree angle inside the sauna.

Confirm the footrest board is level. Hold the cleat in place and remove the footrest board. Mark the top of the cleat with a pencil. Repeat on both sides of the sauna.

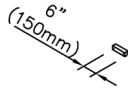
Fasten both side cleats to the sauna walls using your lines as a guide. Place the footrest board across and confirm it is level and touching both cleats as well as the middle support.

13	14-A	E
 6" (150mm)		 #8x2 $\frac{1}{2}$ " (4x60mm)

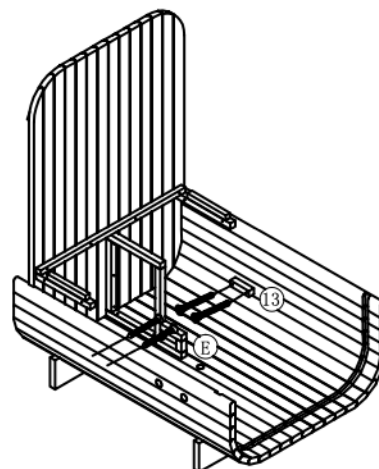
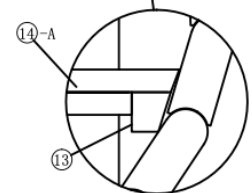
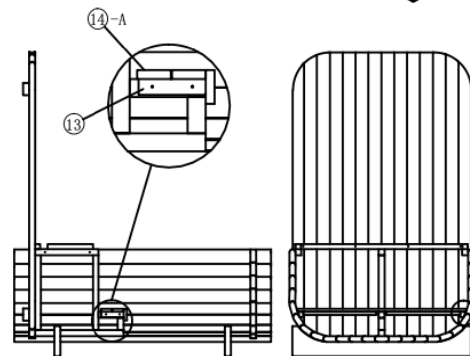
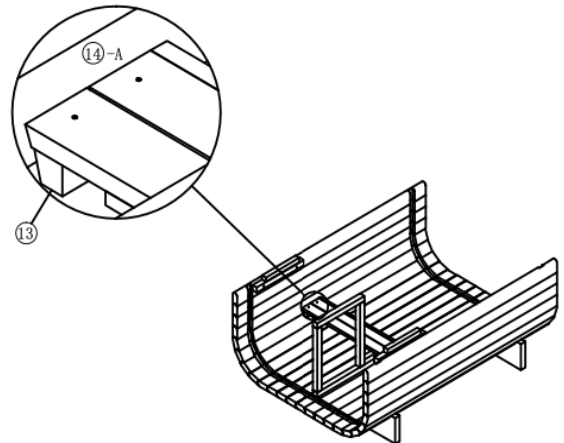



Interior Assembly

Step 13: Place the Bench

Place the bench on top of the cleats so that it sits in the channel created between the back and side cleats.

Confirm that the bench is sitting flat and level, then fasten to the back and side cleats.

If it is not sitting flush and touching the cleats on all sides, your cleat heights may be incorrect, or not be level. Remove the bench top and check before proceeding.

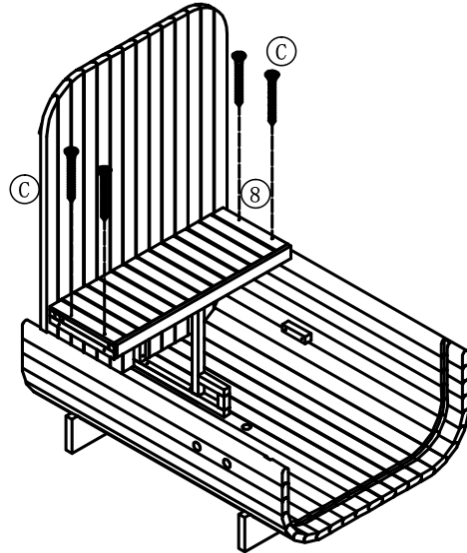

8	C
	
	#8x1 1/2" (4x40mm)



Step 14: Install the Footrest

Fasten the footrest to the two bottom cleats.

If it is not sitting flush and touching the cleats on both sides, your cleat heights may be incorrect, or not be level. Remove the footrest and check before proceeding.

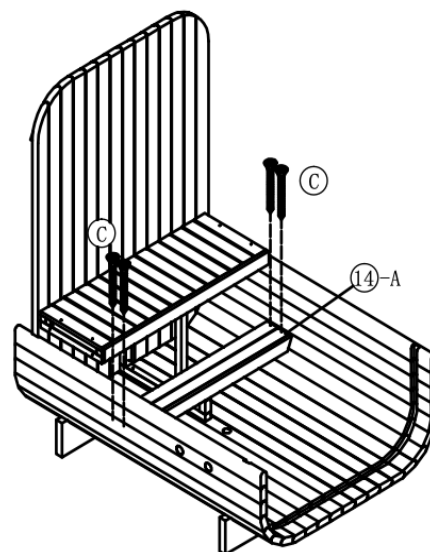

14-A	C
	
	#8x1 1/2" (4x40mm)



Step 15: Install the Backrest

Install the backrest on the back wall at a height comfortable for you.

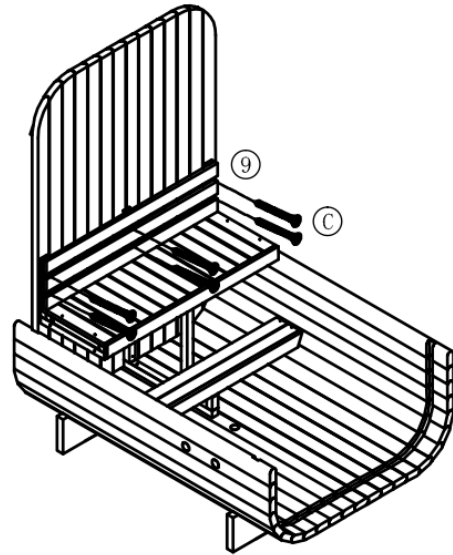

We generally recommend to place the backrest so that it aligns to your mid-back, just below your shoulder blades.

9	C
	 #8x1 $\frac{1}{2}$ " (4x40mm)



Step 16: Install the Towel Peg

The towel peg can be placed on the inside or outside of the sauna according to your preference. One suggested location is shown in the picture; however, feel free to place this where it will be most useful for you.

26	C
	 #8x1 $\frac{1}{2}$ " (4x40mm)

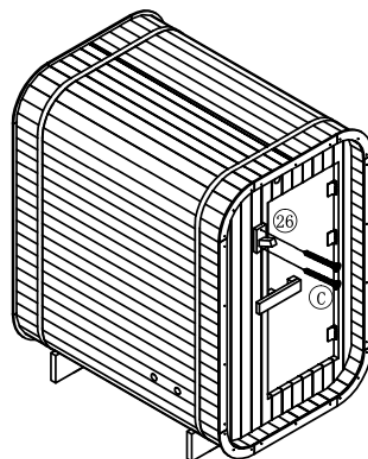





Exterior Finishing

Step 17: Install the Gables

The wooden gables sit on the front and back walls of the sauna as shown.

Fix the wooden gables to the edge of the staves using screws provided.

If not installing the roof tiles, the gables can be left out depending on your aesthetic preference.

21	22	23	A
			 #8x1" (4x30mm)

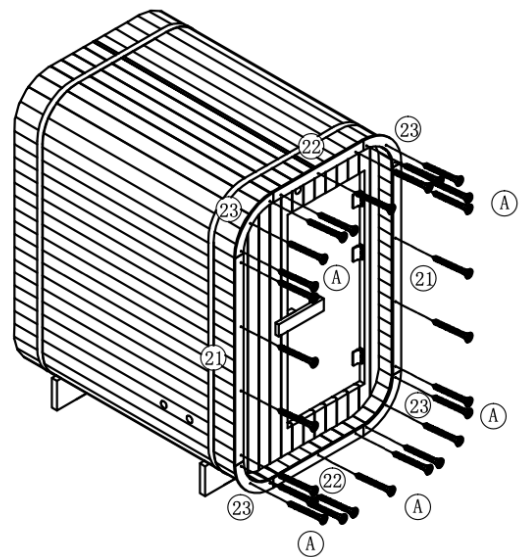
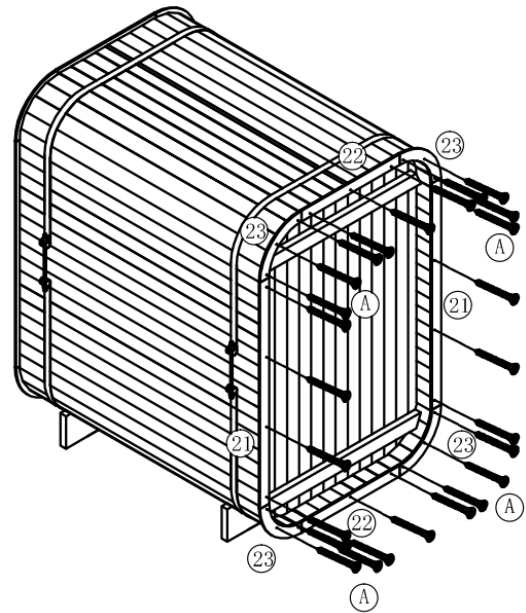

Heater Installation

Step 18a: Mount the Heater and Place the Temperature Sensor – Harvia Spirit Heaters

All electrical wiring must be performed by a **QUALIFIED LICENSED ELECTRICIAN**. Heater installation manuals are available on the Redwood Outdoors website and should be provided to your electrician before installation.

Once the heater is installed, place the heater's temperature sensor. The temperature sensor controls the temperature inside the sauna. The heater will shut off when it senses that the sauna has reached the set temperature.

For **Harvia Spirit** heaters, the mounting plate can be mounted so that the bottom sits approximately 12" off of the floor. Use the mounting hardware to secure the mounting plate to the wall of the sauna.

We recommend placing the thermometer approximately **~14" to the side of the heater, and approximately ~4" below the highest point of the sauna**. Please note that the roof is sloped, and the highest point is along the front wall where the slope is at its highest angle.

Correct temperature sensor placement is crucial to the performance and maintenance of your heater. If the sensor is placed too high or too low, your heater's internal safety switch will engage and shut off the heater before the 60 minute preheat time is finished, and your sauna may not come to temp. Incorrect temp sensor placement can also negatively affect the lifespan of your heater coils.

**If you have any questions about temp sensor placement, please contact Redwood Outdoors Customer Support for assistance.*

Spirit Heater Temperature Sensor Recommended Placement

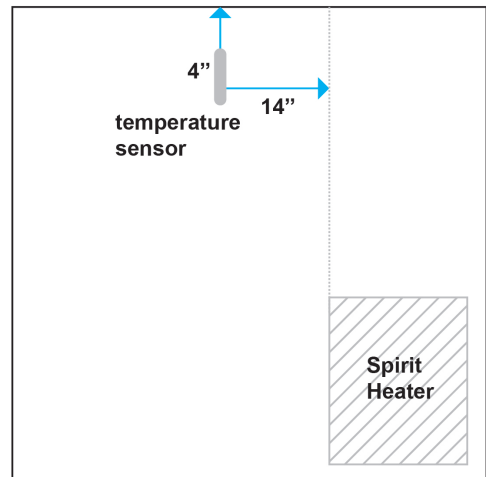

Spirit Mounting Plate Placement

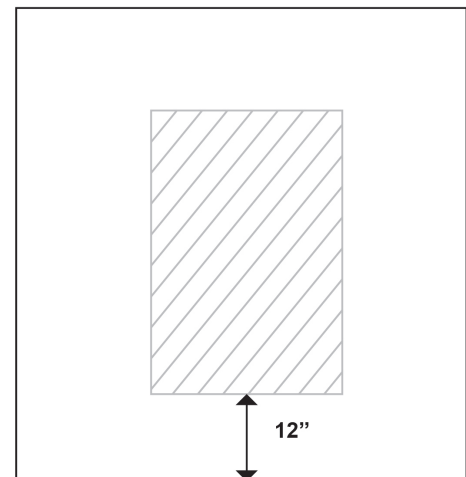

Complete heater manuals are available here



Heater Installation

Step 18b: Mount the Heater and Place the Temperature Sensor – Harvia KIP Heaters

For KIP heaters, position the heater mounting screws approximately **20" off the sauna floor and spaced 15 1/4" apart**. Hang the heater on the mounting screws to ensure it is level and that its base sits **5-7" off the floor**.

All electrical wiring must be performed by **A QUALIFIED LICENSED ELECTRICIAN**. Heater installation manuals are available on the Redwood Outdoors website and should be provided to your electrician before installation.

Once the heater is installed, place the heater's temperature sensor. The temperature sensor controls the temperature inside the sauna. The heater will shut off when it senses that the sauna has reached the set temperature.

For **Harvia KIP** heaters, we recommend placing the thermometer **~14" to the side of the heater and ~14" below the ceiling's highest point**. Make sure the top of the sensor is not covered. The diagram to the right shows the recommended placement.

Correct temperature sensor placement is crucial to the performance and maintenance of your heater. If the sensor is placed too high or too low, your heater's internal safety switch will engage and shut off the heater before the 60 minute preheat time is finished, and your sauna will not come to temp. Incorrect temperature sensor placement can also negatively affect the lifespan of your heater coils.

**If you have any questions about temp sensor placement, please contact Redwood Outdoors Customer Support for assistance.*

KIP Heater Temperature Sensor Recommended Placement

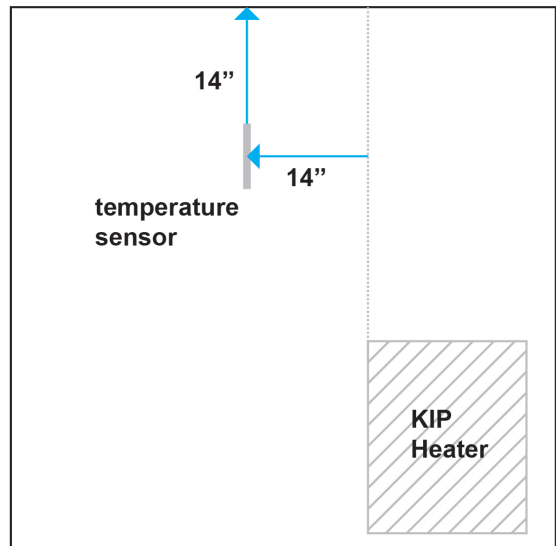

KIP Mounting Screw Placement

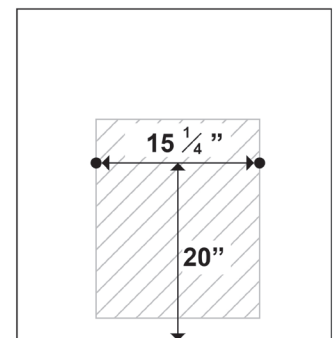

Complete heater manuals are available here



Interior Finishing

Step 19: Install the Light Fixture

A light fixture is provided with your sauna.

The light may be installed anywhere inside or outside of the sauna, as long as it is at least 4ft away from the heater and not installed directly above the heater.

The light fixture must be installed by a licensed electrician. Wiring for the light fixture is not provided and will need to be sourced locally.

The light must be wired to a separate **120v** line.

If you have a Wi-Fi-enabled heater, the light can be wired into the wifi kit's power box and will be controlled by the included control panel or through your mobile app. More information on this will be available in your heater's manual.

If your heater is not wifi-enabled, your electrician will need to supply a separate switch for the light as well.

Your electrician should determine the best way for the wiring to enter the sauna based on your site conditions and fixture placement. Consult with your electrician about how best to hide the wiring from the light.

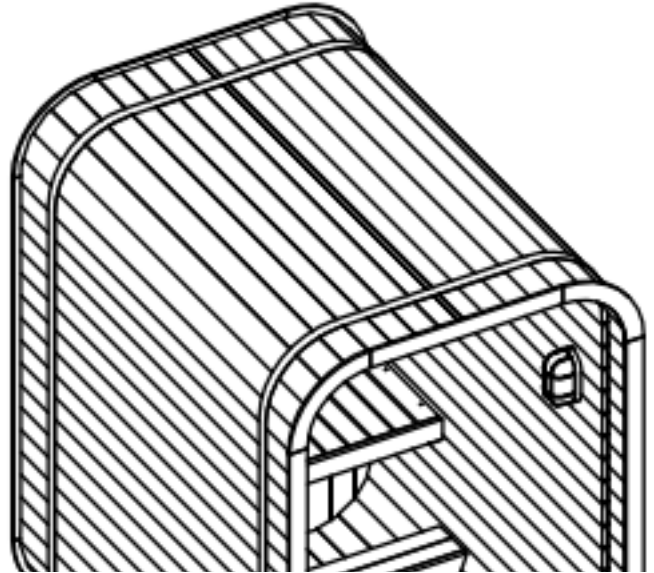



Shingle Assembly

Step 20: Install the Rectangular Strips

Fasten the triangular piece to the outside wall of the sauna on both sides. The piece should be placed approximately $59\frac{3}{4}$ " from the ground level.

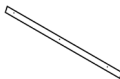
This piece creates a small outward slope that will allow rain to runoff away from the unit. Your first row of shingles will start on this triangular piece.

27	C
	
	#8x1 $\frac{1}{2}$ " (4x40mm)

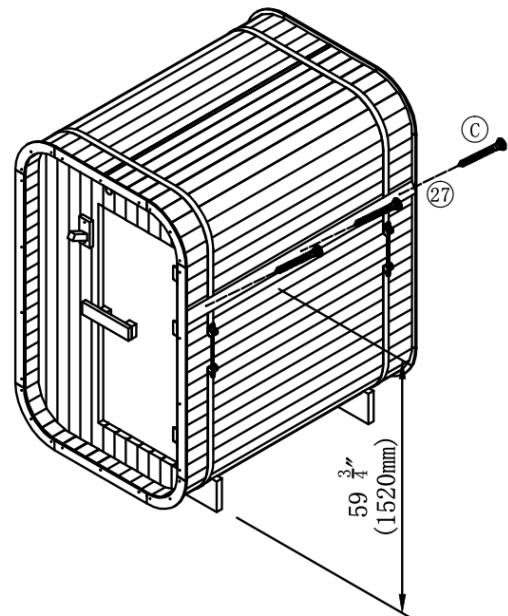
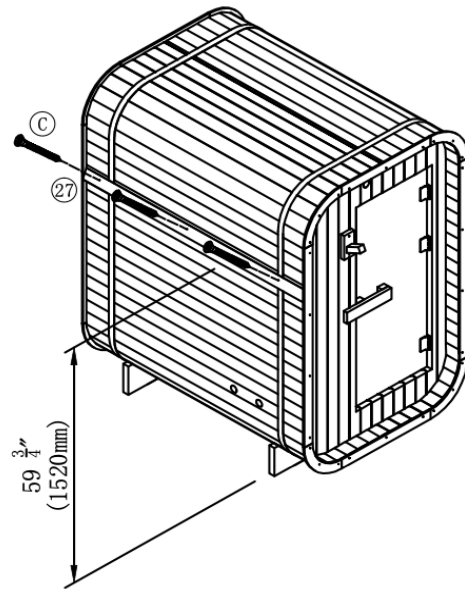

Step 21: Place Roofing Underlay

Spread the underlay evenly across the top of the sauna. The edge of the underlay should line up with the edge of the triangular wood strip installed in the previous step. Cut away any excess underlay that sticks out beyond the edge of the triangular wood strip.

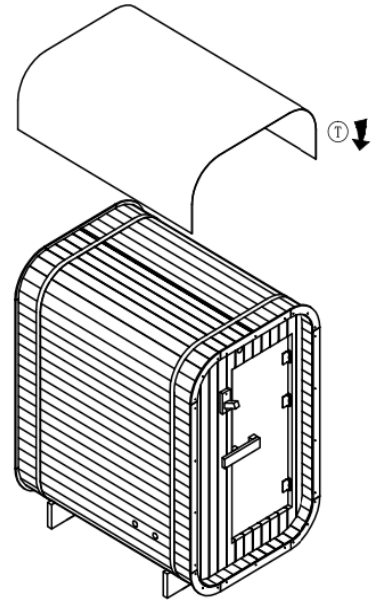
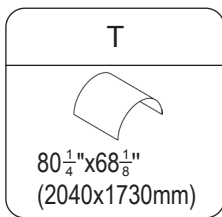

Shingle Assembly

Step 22: Install the Rectangular Strips

The mini cube has two kinds of shingles: shingle strips and roll roofing. Roll roofing is required for the flat area of the roof where there is no slope for runoff. The shingle strips are used on the side of the unit, as they create a nicer aesthetic.

The shingle strips will be placed **first**. For the first row, cut the points off several strips to create a straight edge. This will form your first layer. Your first layer should overhang the triangle piece #27 slightly (<1/2") to allow rain to drip off.

Then place your second row of shingles so the bottom of the diamond point aligns to the straight edge. Continue side to side following this honeycomb pattern. This may require some cutting at the ends to maintain the pattern.



Continue until you have completed **3 rows of the shingle strips** (1 row with a straight edge on both sides + 2 full rows = 3 total) You should finish just below the top corner of the unit; do not continue the shingle strips onto the flat area.

We provide screws with washers that you can use to fasten the shingles. If you have a nail gun or staple, you can use this instead to speed up installation.

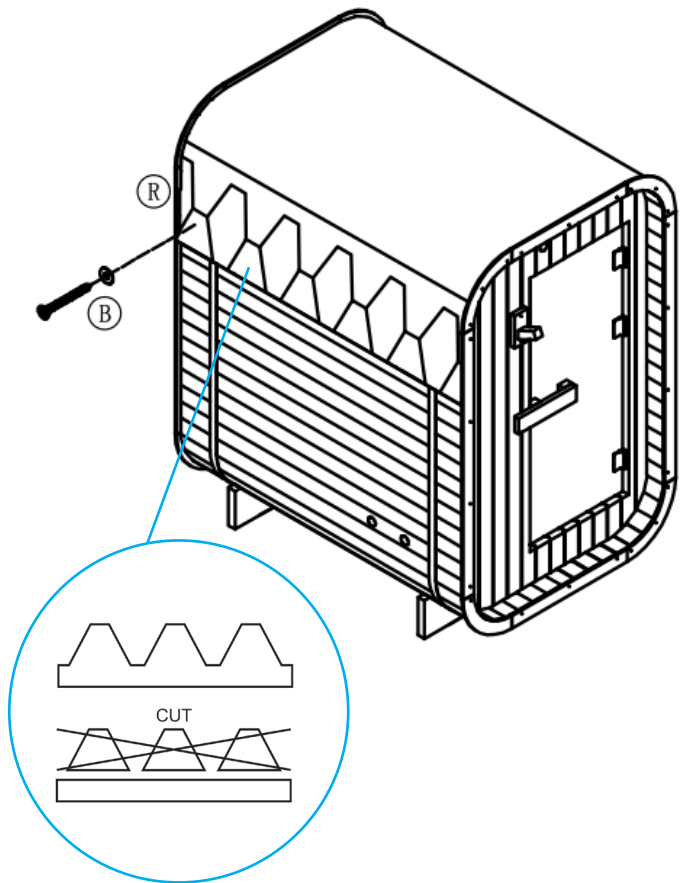
Remove the plastic backing on the shingle strips before installing them.



Shingle strip honeycomb pattern on a barrel sauna

B	R
 #8x $\frac{3}{4}$ " (4x20mm)	

Step 23: Install the Shingle Rolls



Once the strips are in place, install the roll roofing over the top of the sauna as shown below. The top of the roll roofing should overlap the top of the highest shingle strip by ~2".

We provide screws with washers that you can use to fasten the shingles. If you have a nail gun or staple, you can use this instead to speed up installation.

The roofing rolls will overlap near the middle of the sauna. For added protection, apply a bead of caulk to the seam between the two rolls. This will prevent water from flowing under the seam and onto the sauna roof.



Example of finished shingles

B	S
 #8x $\frac{3}{4}$ " (4x20mm)	 62"x39" $\frac{3}{8}$ " (1575x1000mm)

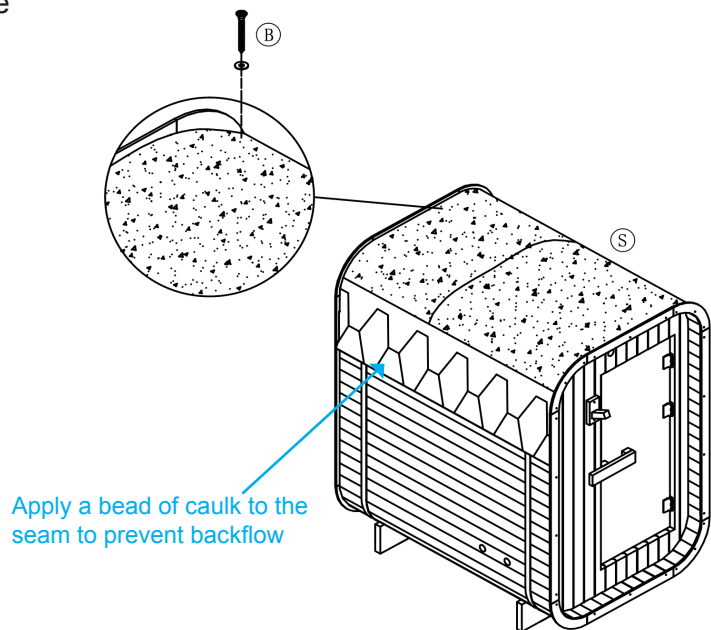

Maintenance

Maintaining Your Sauna After Installation

• Exterior Wood Treatment

Your sauna is designed for outdoor use, and the wood we use is naturally resistant to the elements. Nonetheless, over time your sauna will naturally weather, and the color of the wood will start to turn gray, especially in sunny areas. If you'd prefer to preserve the original exterior color of your sauna or even change the color completely, we recommend treating the **exterior only** with a water-based stain-and-seal. A stain-and-seal treatment will add extra protection against mildew as well. **Please note it is important that the inside of the sauna remains untreated to prevent fumes.**

• Roofing and Waterproofing

Without a roof installed, it is normal to experience water leaking through the roof boards. The interlocking staves do not form a watertight seal. We recommend installing our asphalt roof shingles, or sourcing your own roofing materials locally. Some customers have installed metal roofs or cedar shingles which work.

It's normal for some water to seep into your sauna, especially on windy days if rain is blowing onto the side walls of your sauna. This will not harm your sauna or diminish its lifespan. After a heavy rainfall, we recommend you run the heater for a 1-hour cycle to dry out the room. Running the heater a few times a week during the wetter months will help prevent mold or mildew from developing.

• Interior Maintenance and Cleaning

Treating your benches with paraffin oil will reduce the amount of sweat and dirt absorbed into the wood. We recommend treating new benches before using them; repeat the treatment once or twice a year after cleaning the sauna. Paraffin oil is colorless and odorless, and it will give the wood a slightly darker 'wet' look after it's applied. Be sure to **only use sauna-grade paraffin oil**, like Harvia Paraffin Oil, to prevent fumes. Paraffin lamp oil should not be used under any circumstances. Wood surfaces must be completely dry before applying an oil treatment.

Under normal conditions, washing the interior of the sauna every 3 to 4 months will maintain cleanliness. We recommend using Harvia Sauna Cleanser or another suitable cleaning solution for wood. Refrain from using ammonia or harsh chemicals.

Clean the wood with a sponge or soft bristle brush and your cleaning solution. Always brush with the grain of the wood. If dirt is embedded in the benches, you can sand them down lightly. Rinse the sauna thoroughly with water to remove all the cleaning product. Run the heater for 1 to 2 hours to dry out the room and then leave the door open to air out the sauna.

For stainless steel surfaces on your heater, we recommend Harvia Sauna Heater Cleanser which removes limescale stains.

Re-stack your sauna rocks every 6 months as the rocks will break down over time in high heat. Ensure that the rocks do not shift and cause the heater coils to bend into one another. We recommend replacing your sauna rocks completely every 12-18 months.

Maintenance and Warranty

After you have finished each sauna session, we recommend running the heater for an additional 60 minute cycle with the door closed. This will dehumidify the room and dry out the wood. If you are using your sauna regularly (i.e., multiple times a week) and drying out the room after each session, this should largely prevent mold formation.

If you are not using your sauna regularly, run a dehumidifier and/or fan inside the sauna to keep air circulating (and empty the dehumidifier water tank regularly). Also place desiccants (e.g., a commercial desiccant such as Damp-Rid or non-commercial desiccant such as charcoal briquettes/kitty litter) on dishes and place them around the inside of the sauna.

• Preventing and Treating Mold

The key to preventing mold from forming is to ensure the inside of the sauna is frequently dried out. Mold can develop as a result of moisture getting trapped inside the sauna over prolonged periods of exposure to sweat and steam or precipitation.

If you see mold on the inside or outside of your sauna, this should be treated early before it has time to grow and take hold. Clean the affected area with household white vinegar and gently scrub the area with a soft scrub brush and soapy water.

If you are unable to remove the mold with vinegar and soap, try stronger cleaning agents such as 30 Seconds Outdoor Cleaner or Behr All-in-One Wood Cleaner. Rinse the sauna thoroughly with water to remove the cleaning solution. Run the heater for 1 to 2 hours to dry the room. Any rags or scrub brushes that come into contact with the mold must be disposed of. **Proper protective equipment (goggles, mask, gloves, etc.) must be worn when removing mold.**

• Instructions for First Time Use

Before placing the rocks in your heater, wash them off and dry them to remove any dust. Once they are dry, add the rocks to your heater. Make sure your rocks are not stacked too tightly to allow for appropriate air flow.

To prepare your heater for your first sauna session, turn your heater on to its highest heat setting for an hour. This will burn off the protective oil on the heater coils that may cause a mildly unpleasant smell. The sauna should not have anyone bathing in it during this cycle. Never run your heater without the rocks. After the initial 1 hour cycle, leave the door open and let the sauna air out for several hours.

Now your sauna is ready to use!

• Warranty

Our saunas and sauna heaters come with a 1-year limited warranty. Please refer to <https://www.redwoodoutdoors.com/warranty> for detailed warranty information on our products.

User Guide

How to Take a Traditional Finnish Sauna

- Traditional sauna bathing is done in 'rounds' or intervals. A round involves heating the body up and then cooling it down. A typical round consists of 10-15 minutes in the sauna followed by a cool down period of approximately 5 minutes.
- Preheat the sauna to your desired temperature (traditional Finnish saunas run between 160°F and 185°F). Preheating typically takes 45 minutes to an hour. If the ambient temp outside is below 20°F, preheating may take longer than one hour. Digital sauna heaters can be started remotely via Wi-Fi. Manual control sauna heaters can be set on a delay timer to start at a predetermined time up to 8 hours in the future.
- All residential sauna heaters have a maximum independent run time of 1 hour for safety reasons, but they can be restarted again as many times as desired. When you enter the sauna for your first round, begin by resetting the heater to the full 1 hour.
- The first sauna round is typically enjoyed dry, which means no water is added to the rocks. Heat stacks in a sauna, so it's normal that the floor will be much cooler than at your head. If you find your head gets too hot, you can wear a sauna hat, which will help keep your head cooler and allow you to feel more of the heat sensation on your body.
- After 10-15 minutes, exit the sauna and begin your cool down phase. If you have an outdoor shower or cold plunge tub, this can be used during your cool down and provides for a much more rapid and effective cool down phase. The goal is to bring your body temperature back down in preparation for the next hot phase.
- The 2nd and 3rd sauna rounds are typically enjoyed with added humidity, which increases the sensation of heat. Water can be gently ladled on to the rocks to create steam or 'löyly'.
- You may add aromatherapy oils to your water bucket to create a scented steam. The classic scents used in Finland are birch, pine and eucalyptus. All aromatherapy oils are formulated differently, so make sure yours does not leave any residue on the rocks.
- When pouring water on the rocks, do so slowly and only when the sauna is at full temperature. The water should evaporate instantly when it hits the rocks. If you notice water coming out the bottom of the heater it means you are pouring too fast or too much. If you like to use a lot of water in the sauna, it is recommended to buy a sauna fountain. These stone fountains sit amongst the rocks and help create steam.
- A typical sauna session is 2 or 3 rounds. Do not skip the cool down phase on your final round. A sauna session ends with a cool down, after which you can take a warm shower.
- It is important to drink water during a sauna session. You should aim to drink at least 24 ounces of water during a session.
- Excessive heat exposure can be harmful to a person's health. People with certain health conditions should consult their physicians before using the sauna.

***SAUNA BATHING IS NOT RECOMMENDED FOR CHILDREN UNDER 14.
CHILDREN MUST BE SUPERVISED BY ADULTS.***

User Guide

Important Note About Heat-Up Times

During colder winter months, your sauna will take longer to reach the desired temperature. This is **normal** and is due to external conditions.

Several factors contribute to slower heat-up times in winter:

- **Ambient Temperature:** When your sauna starts heating from a low outdoor temperature—especially near or below freezing—the heater must work harder and longer to raise the room’s temperature.
- **Cold Rocks:** It takes longer to heat the rocks in the heater that are at the same low temperature as the air inside your sauna. The rocks must heat up first before the room can start heating.
- **Heat Loss Through Surfaces:** The sauna’s walls, floor, and roof are much colder. These surfaces absorb heat and lose heat to the environment as the sauna warms up, reducing the speed the room’s temperature rises.
- **Wind and Airflow:** Outdoor air movement can increase heat loss, especially if the sauna is not in a sheltered location.
- **Humidity and Snow:** Moisture in the air, snow on the roof, or frost on the panels can draw heat away from the interior as the heater operates.

To improve heat-up times in winter:

- Allow extra time for the sauna to preheat before use.
- Make sure the door is kept closed to minimize heat loss.
- Clear snow or frost from the exterior before use if possible.
- Consider installing a windbreak or shelter if your sauna is in a particularly exposed area.

Please note that most sauna heaters have an automatic safety shutoff after 60 minutes. To continue heating after 60 minutes have passed, you must restart the heater.

IMPORTANT NOTICE

YOU ARE SOLELY RESPONSIBLE FOR: (A) ENSURING COMPLIANCE WITH ALL APPLICABLE BUILDING CODES, ZONING, ORDINANCES, BUSINESS DISTRICT OR ASSOCIATION RULES, COVENANTS, CONDITIONS, AND RESTRICTIONS, LEASE OBLIGATIONS, LANDLORD OR OWNER APPROVALS OR REQUIREMENTS RELATED TO ANY PRODUCTS YOUR PURCHASE; AND (B) OBTAINING ANY PERMITS OR AUTHORIZATIONS NECESSARY FOR INSTALLATION AND/OR USE OF SUCH PRODUCTS, INCLUDING ANY PAYMENT OF ANY FEES OR OTHER CHARGES FOR PERMITS OR AUTHORIZATIONS (COLLECTIVELY, "LEGAL REQUIREMENTS"). THIS INSTALLATION MANUAL IS PROVIDED SOLELY AS A COURTESY TO YOU AND DOES NOT CONSTITUTE ANY WARRANTY BY REDWOOD OUTDOORS TO YOU REGARDING THE PLACEMENT OR INSTALLATION OF THE PRODUCT. THIS MANUAL IS NECESSARILY GENERAL IN NATURE AND MAY NOT TAKE INTO CONSIDERATION ALL OF THE CONDITIONS AND CIRCUMSTANCES OF YOUR PROJECT. YOU ARE SOLELY RESPONSIBLE FOR DETERMINING WHETHER THE PLACEMENT AND INSTALLATION OF THE PRODUCT IS APPROPRIATE AND IN COMPLIANCE WITH ALL LEGAL REQUIREMENTS. YOU SHOULD CONSULT QUALIFIED CONSTRUCTION, ELECTRICAL, ENGINEERING OR OTHER SERVICE PROFESSIONALS IF YOU HAVE QUESTIONS ABOUT THE PROPER INSTALLATION OF THE PRODUCT. REDWOOD OUTDOORS AND ITS SUPPLIERS WILL NOT BE LIABLE TO YOU FOR ANY CLAIMS OR DAMAGES ARISING FROM YOUR INSTALLATION, MAINTENANCE, OR REPAIR OF ANY PRODUCT.



REDWOOD
OUTDOORS

View this manual online
here



View the assembly video
here



Contact Info

Phone: 1-800-567-8036
Email: support@redwoodoutdoors.com
Website: www.redwoodoutdoors.com

Version

Date: Jun 17, 2025
Version: 4.16