

Assembly Instructions

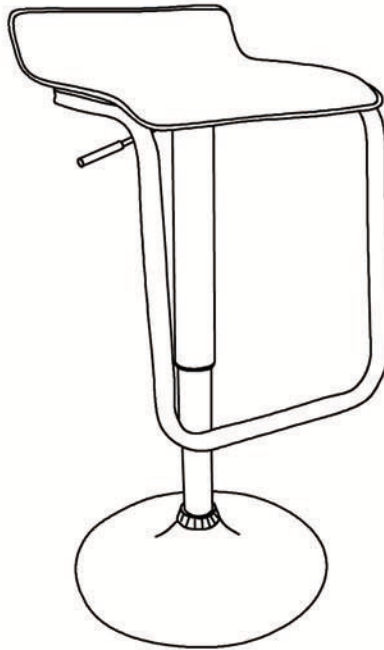

ASSEMBLY RATING

The Assembly Rating is a 5-point system that shows the degree of effort needed in assembling a specific product (with 1 being easy and 5 being difficult). For some products, two persons are recommended.

Tools Required For Assembly:

Allen Wrench



EASY  DIFFICULT

Thank you for your purchase!

We hope you will enjoy your new product for many years to come. Our commitment to providing quality products does not simply end when a purchase is made. We stand behind our products and will provide any support needed in order for you to fully enjoy your purchase. Your satisfaction is the greatest recognition we could have.

Because we value your trust in our company, we will do our best to meet your service expectations.

ASSEMBLY & CARE ADVICE

FOR YOUR FURNITURE TO LAST, CORRECT ASSEMBLY AND PROPER MAINTENANCE ARE NECESSARY. PLEASE FOLLOW THE INFORMATION PROVIDED BELOW TO FULLY ENJOY YOUR FURNITURE.

BASIC ASSEMBLY TECHNIQUES

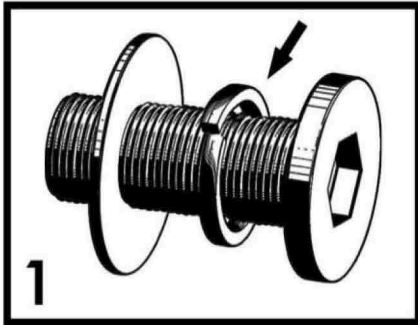

1 When lock or spring washer is used in an assembly, please make sure the lock or spring washer is placed between the larger flat washer and the head of the screw or bolt.



2 Position each part correctly and insert screws or bolts into their respective holes by hand tighten or using the proper hand tool. Only tighten when step is completed or when instructed to do so.

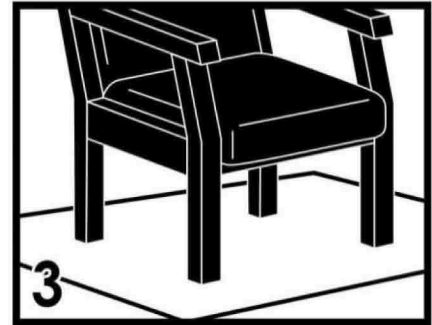

3 Use cardboard or carpet area when assembling furniture to prevent scratches. Make sure the furniture rests on a flat and level surface with each leg evenly touching the floor.

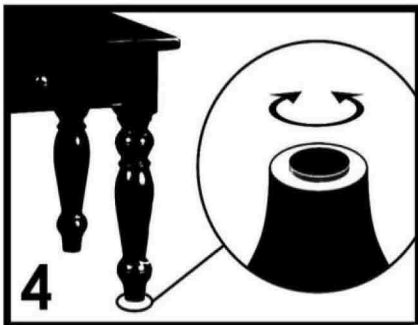

4 Some furniture comes with height adjustment knobs underneath each leg. To lower or to raise each leg, you need to turn clockwise or counterclockwise, respectively.

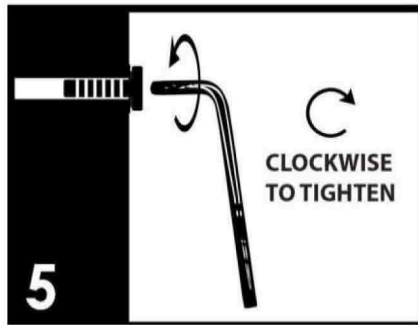

5 Make sure all parts are properly aligned, then use the appropriate hand tool to completely tighten the bolts or screws. Do not use power tools and do not overtighten.

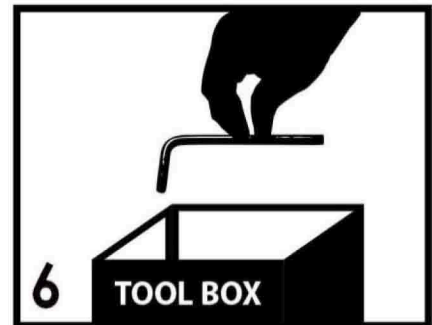

6 Save the instructions and store the Allen wrench or any supplied tool for later maintenance. After two weeks, check and tighten any loose hardware and repeat again every six months thereafter.

IT IS THE USER'S RESPONSIBILITY TO MAINTAIN THE FURNITURE. THE HARDWARE MAY LOOSEN OVER TIME AND MAY CAUSE THE FURNITURE TO BE WOBBLY AND UNABLE TO SUPPORT ITS INTENDED WEIGHT CAPACITY. THIS MAY LEAD TO COLLAPSE AND MAY CAUSE SERIOUS INJURY.



FAILURE TO FOLLOW THE GUIDELINES ABOVE MAY RESULT IN INJURY AND/OR PROPERTY DAMAGE.



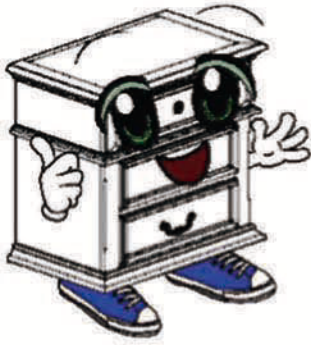



ALL RIGHTS RESERVED.





Before you begin, please read Page 2 of "Assembly and Care Advice".

And remember, do not tighten until each step is completed or instructed.

Parts List

-  #1X1PC
SEAT
-  #2X1PC
FOOT RACK PLATING
-  #3X1PC
STRAIGHT BIG CONJOINED
-  #4X1PC
BASE
-  #5X1PC
GAS LIFT CYLINDER
-  #6X1PC
BASE RING

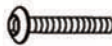
Hardware List

-  #AX4PCS
BOLT M6*16MM
-  #BX4PCS
BOLT M6*32MM
-  #CX8PCS
FLAT WASHER M6*18*1.2MM
-  #DX1PC
ALLEN WRENCH

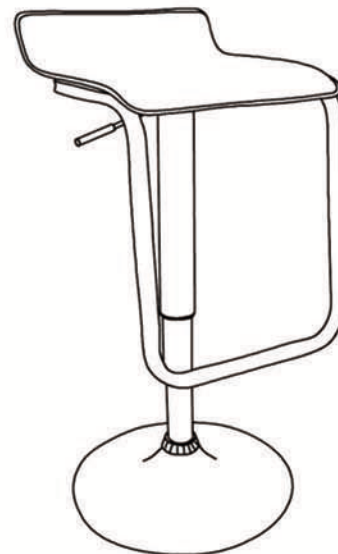



2. Slide the base ring (#6) down the gas lift cylinder (#5).

1. Insert the gas lift cylinder (#5) into the center hole on the base (#4).

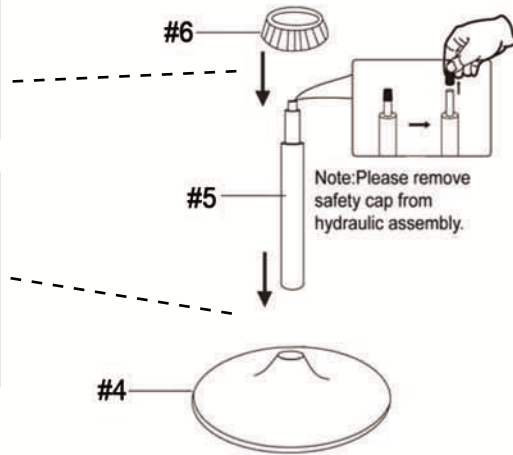

#A 4 pcs
#C 4 pcs
#D 1 pcs

1. Prepare 4 bolts assemblies by inserting a flat washer (#C) onto the bolts (#A).

2. Align the foot rack plating (#2) to the holes along the bottom of the seat (#1), then insert a bolt into each hole and secure.

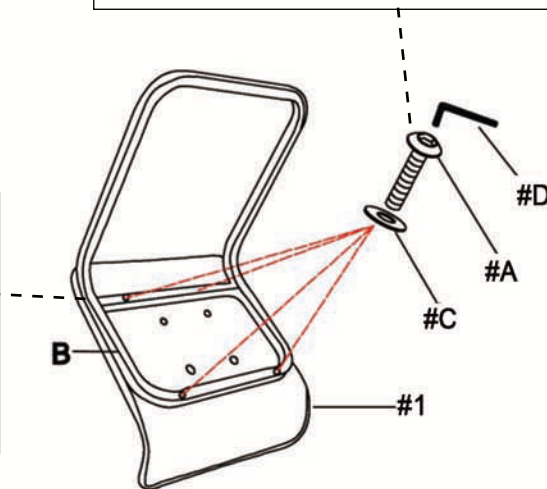



- #B 4 pcs
- #C 4 pcs
- #D 1 pcs

1. Prepare 4 bolts assemblies by inserting a flat washer (#C) onto the bolts (#B).

2. Align the straight big conjoined (#3) to the holes along the bottom of the seat (#1), then insert a bolt into each hole and secure.

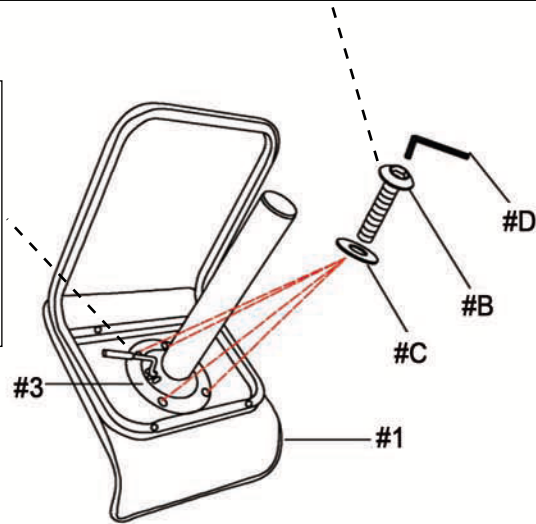

Place the straight big conjoined (#3) onto the gas lift cylinder (#5).

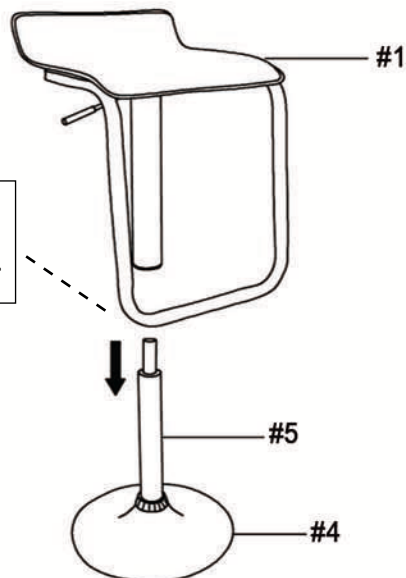

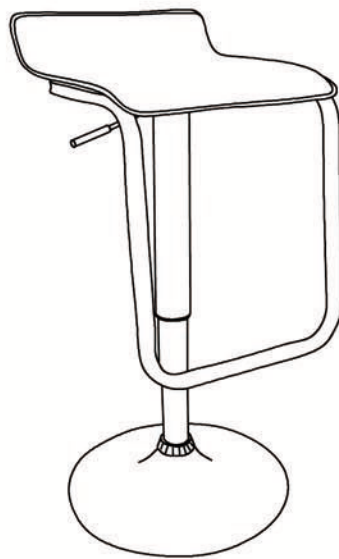

ASSEMBLY IS COMPLETED