

ASSEMBLY INSTRUCTION

A Table Top **B** Leg **C** Side Rail **D** Middle Rail

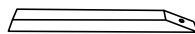
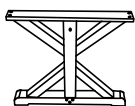
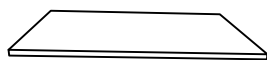

1pc

2pcs

2pcs

1pc

E Reinforcing Bar

F Bolt
Ø5/16"x1-1/2"

G Bolt
Ø5/16"x2"

H Flat Washer
Ø5/16"x22mm



1pc

8pcs

4pcs

12pcs

I Lock Washer
Ø5/16"x13mm

J Allen Key
M5

K Bolt
Ø5/16"x3-3/4"

L Half Moon Nut
Ø5/16"



12pcs

1pc

2pcs

2pcs

M Hex Nut
Ø5/16"x1/2"x6mm

N Spanner
5/16"

O Bolt
Ø1/4"x2-1/4"

P Flat Washer
Ø1/4"x19mm

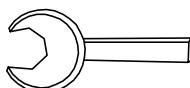

2pcs

1pc

4pcs

4pcs

Q Lock Washer
Ø1/4"x11mm

R Allen Key
M4



4pcs

1pc

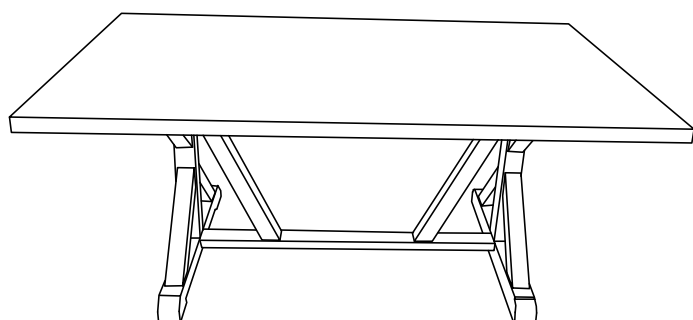

This page lists all the contents included in the box. Please take the time to identify the hardware as well as the individual components to this product. As you unpack and prepare for assembly, place the contents on a carpeted or padded area to protect them from damage.

- 1** Assembling Middle Rail (D) to Leg (B), rotate Bolt (K) to Leg (B) Firstly, then attach Middle Rail (D) to Leg (B) through Bolt (K). Next using Half Moon Nut (L) and Hex Nut (M) to lock with Bolt (K) by Spanner (N) as below shown.

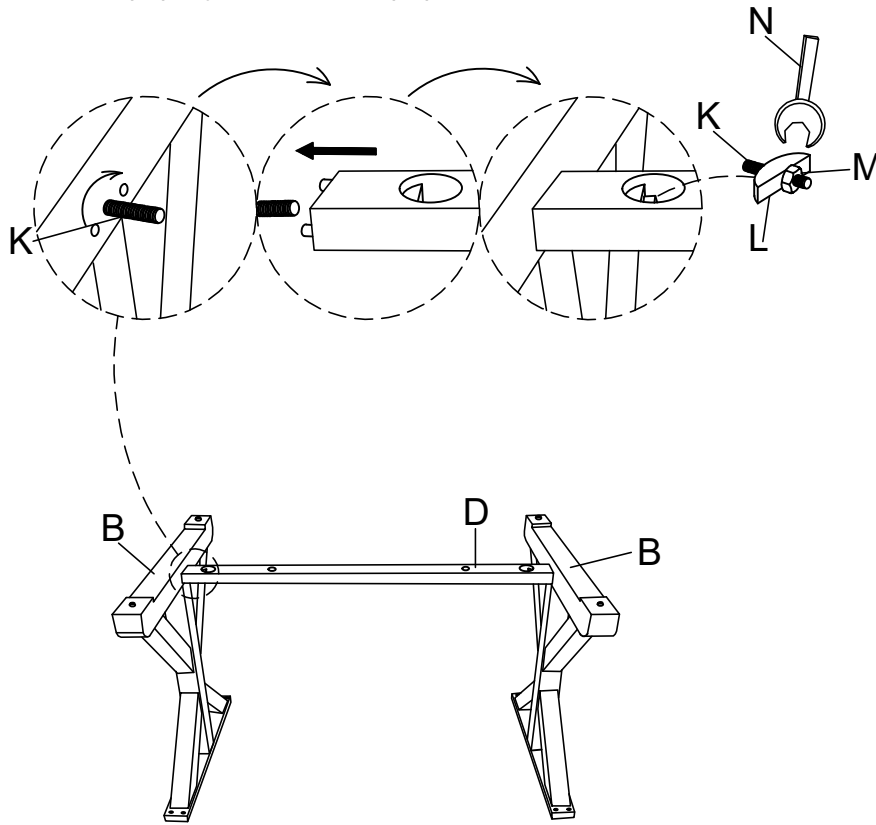

- 2** Attach the Side Rail (C) to the Middle Rail (D) & Leg (B) using Bolt (G), Lock Washer (I) & Flat Washer (H) by Allen Key (J) as below shown.

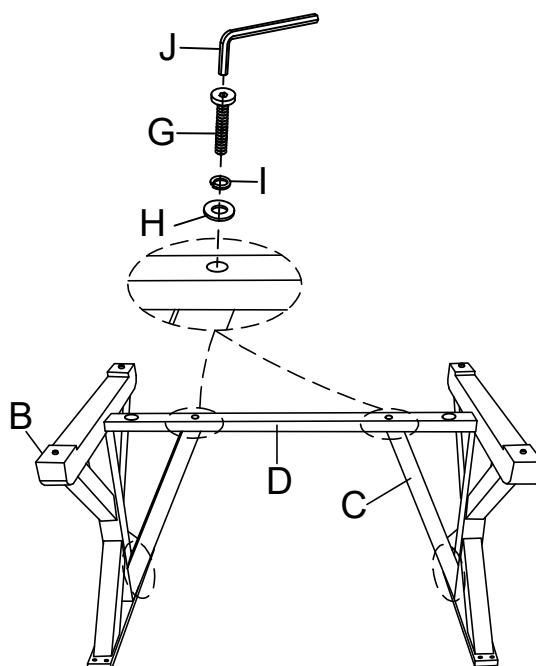

- 3** Attach pre-assembled Leg (B) to Table Top (A) using Bolt (F), Flat Washer (H) & Lock Washer (I) by Allen Key (J) as below shown. Then attach Reinforcing Bar (E) to Table Top (A) using Bolt (O), Flat Washer (P) & Lock Washer (Q) by Allen Key (R) as below shown.

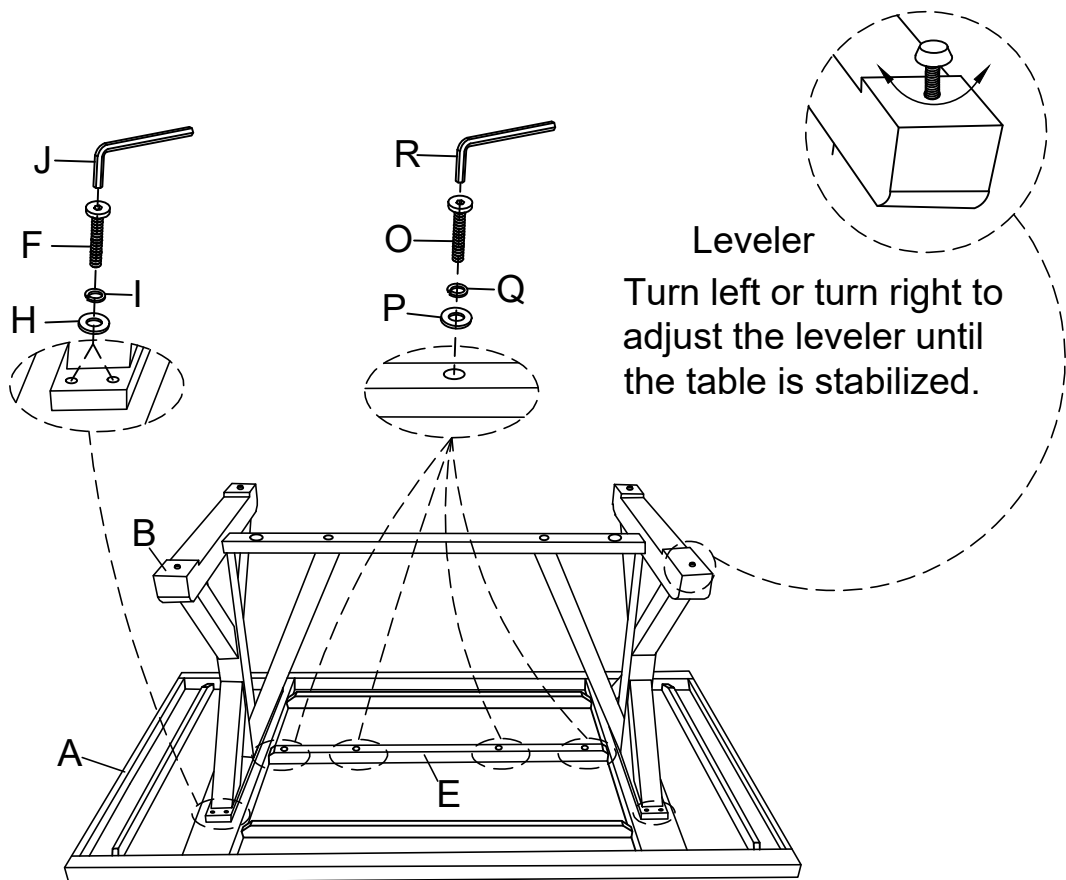













Cleaning & Care

Treat surface with care. Surface is resistant to scratches but is not scratch resistant. Clean surfaces with a dry or damp soft cloth. Do not use abrasive cleaners. Hardware may loosen over time. Periodically check that all connections are tight.

ASSEMBLY INSTRUCTIONS

DINING CHAIR

A Chair Back  1 pc	B Seat Frame  1 pc	C Left Supporter  1 pc	D Right Supporter  1 pc
E Front Leg  2 pcs	F Seat  1 pc	G Pan Head Bolt 1/4", 5/8"  8 pcs	H Lock Washer 1/4"  8 pcs
I Flat Washer 1/2"  8 pcs	J Flat Head Bolt 1/4", 1"  6 pcs	K Wood Screw M5, 3/4"  3 pcs	L Allen Wrench 2 3/4", 1/4"  1 pc



This page lists all the contents included in the box. Please take the time to identify the hardware as well as the individual components to this product. As you unpack and prepare for assembly, place the contents on a carpeted or padded area to protect them from damage.

- 1** Attach Seat Frame (B) to Chair Back (A) using Pan Head Bolt (G), Lock Washer (H) and Flat Washer (I) with Allen Wrench (L).

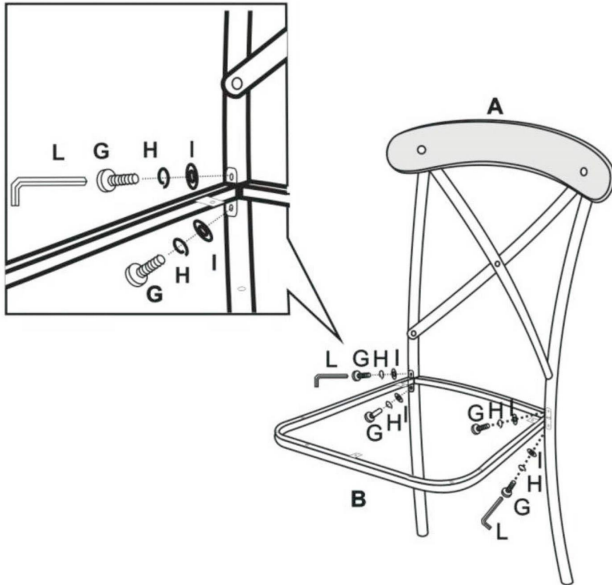

- 2** Attach Left & Right Supporter (C&D) to Chair Back (A) and Seat Frame (B) using Pan Head Bolt (G), Lock Washer (H) and Flat Washer (I) with Allen Wrench (L).

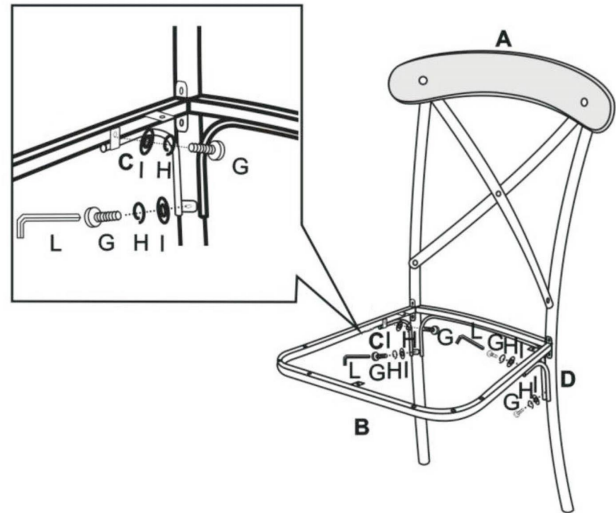

Take the Allen Wrench and turn the bolts until the legs are secured. **DO NOT TIGHTEN COMPLETELY.** Stop when you feel you are adding force to tighten the bolts.

- 3** Attach Front Leg (E) to Seat Frame (B) using Flat Head Bolt (J) with Allen Wrench (L).

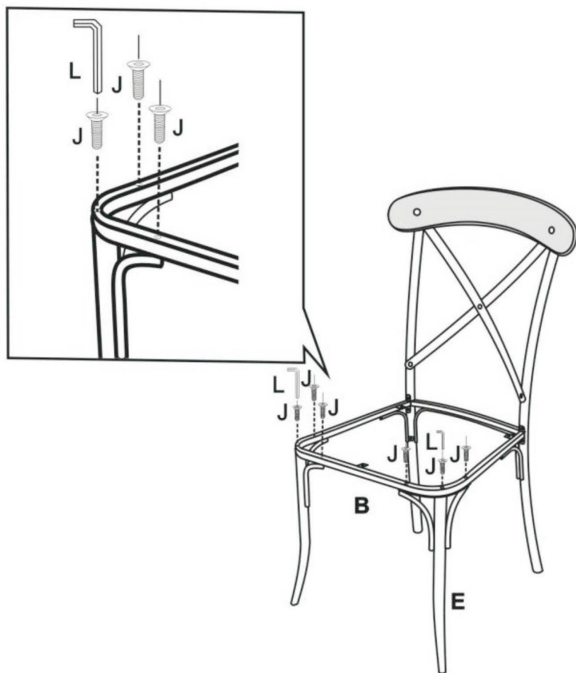

- 4** Attach Seat (F) to Seat Frame (B) using Wood Screw (K) with a screwdriver (not provided).

Stand the chair on an even surface and check for balance. If it wobbles, press down on the uneven leg and tighten the bolts. Once balanced, apply even pressure to the center and tighten all bolts without over-tightening.

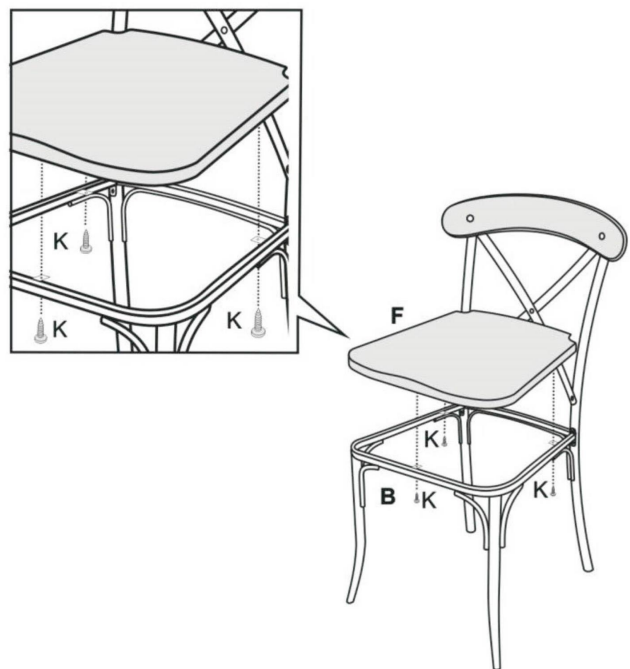

Helpful Tip: While tightening the bolts from underneath, have someone sit in the chair.

Cleaning & Care

Treat surfaces with care. Surfaces are resistant to scratches but are not scratch resistant. Clean surfaces with a dry or damp soft cloth. Do not use abrasive cleaners. Hardware may loosen over time. Periodically check that all connections are tight.