

Aluminum Outdoor Corner Sofa 4-piece Set

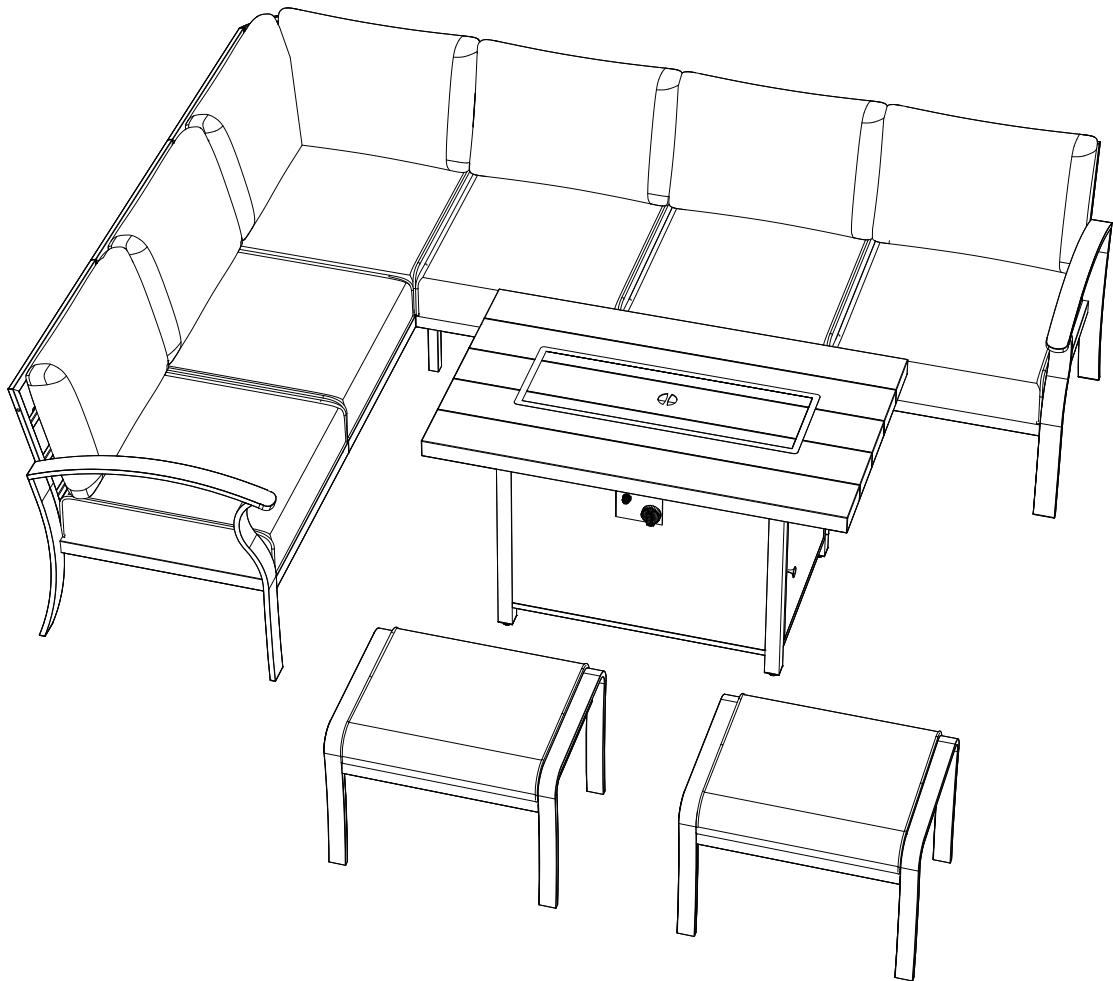

IMPORTANT

PLEASE READ BEFORE YOU COMMENCE ASSEMBLY

Follow the guidelines in this user guide to ensure correct assembly and care for this product.

SPECIFICATIONS

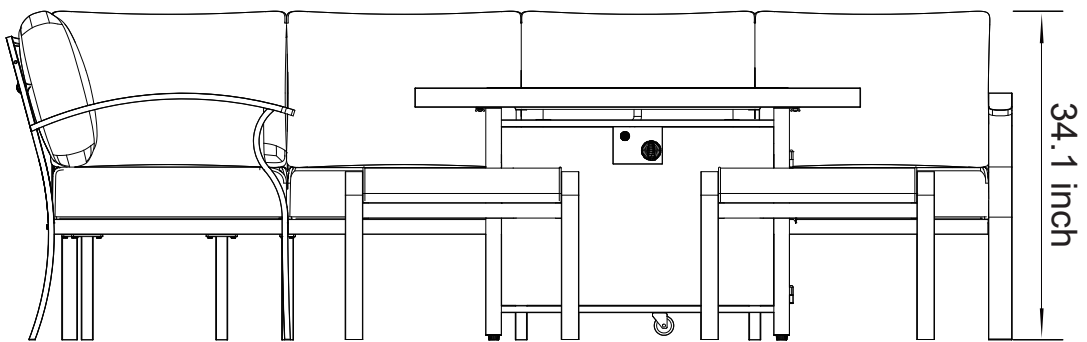
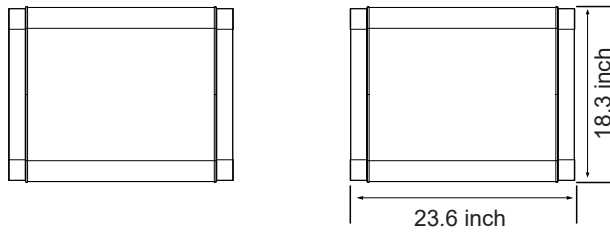
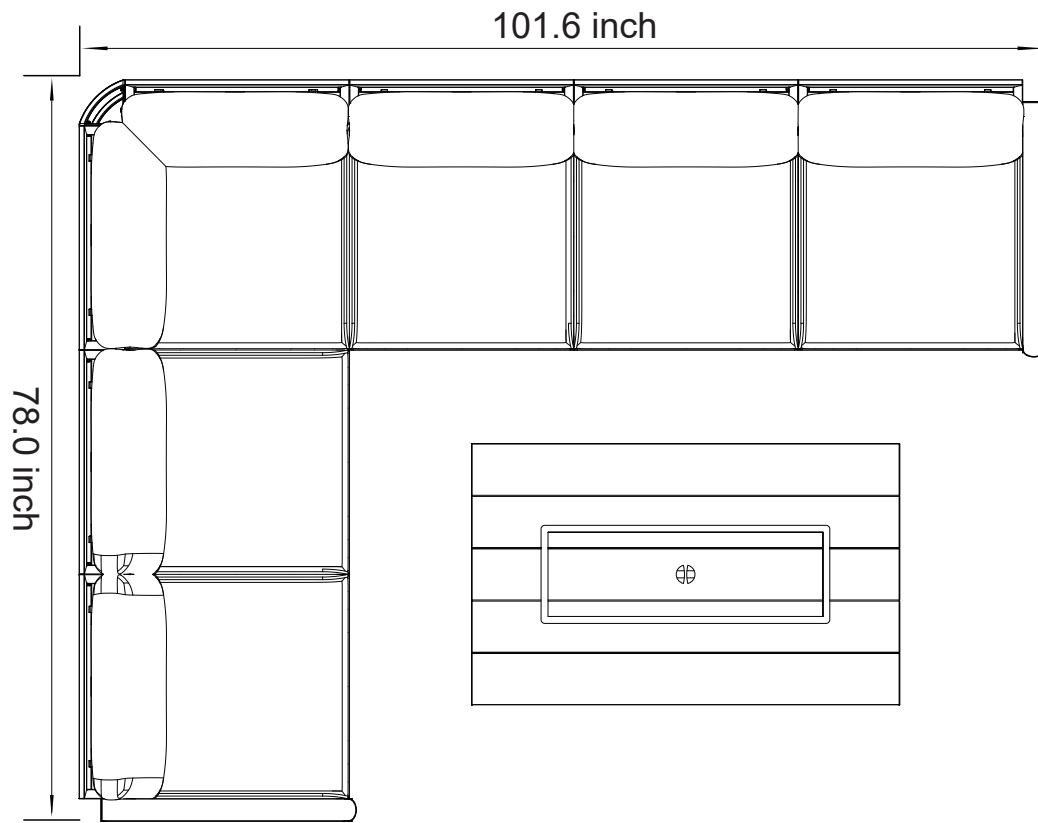

Catalog

Specifications.....	01
Before you begin.....	03
Part List And Extra	04
How to Assemble The Two-person Sofa.....	06
How to Assemble The Three-person Sofa	09
How to Assemble The Corner Sofa	12
How to Use The Seat Cushions And Pillows.....	18
How to Use The Footrest	19
Cushion Manual	21



Before You Begin

Assembly Instructions:

Instructions are supplied in this manual and contain all appropriate information for your building model.

Review all instructions before you begin and during assembly, follow the step sequence carefully for correct results.

Parts and Parts List:

Check to be sure that you have all the necessary parts for building.

Separate contents of the carton by the part number while reviewing parts list.



Familiarize yourself with the hardware and fasteners for easier use during construction.

The first few steps show how to join related parts which is to obtain larger sub-assemblies be used later.

All parts are packaged within the carton.



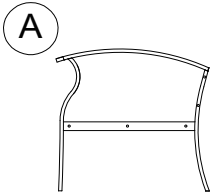
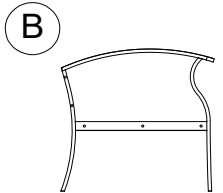
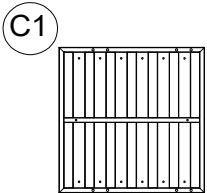
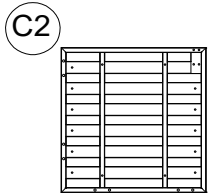
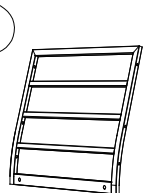
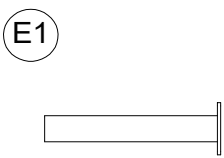
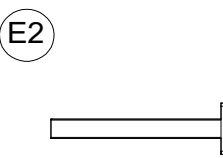

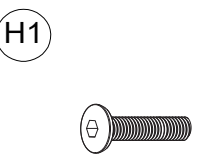
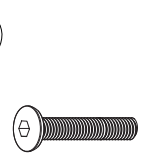
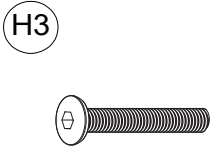
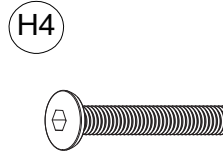
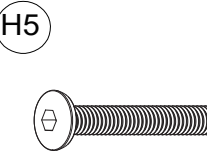
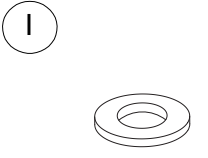
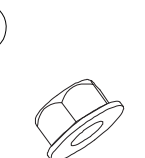
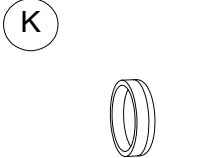
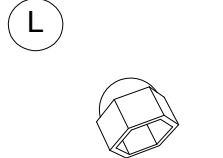
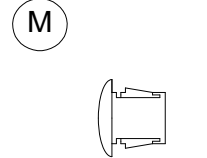
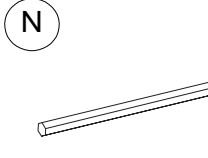
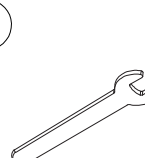
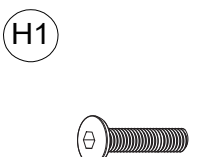
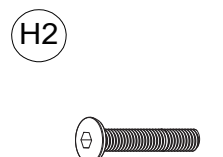
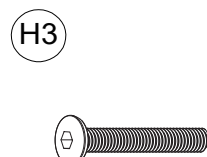
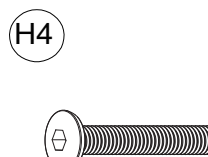
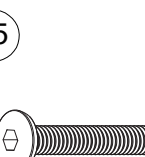
Note that extra fasteners have been supplied for your convenience.

PART LIST

Parts List (Box A)				
 <p>Left Sofa Armrest</p>	 <p>Right Sofa Armrest</p>	 <p>Base Plate</p>	 <p>Corner Base Plate</p>	 <p>Sofa Backrest</p>
1 PC	1 PC	5 PCS	1 PC	7 PCS
 <p>Corner Sofa Legs</p>	 <p>Sofa Legs</p>	 <p>Corner Connectors</p>	 <p>M6x15</p>	 <p>M6x30</p>
1 PC	10 PCS	1 PC	44 PCS	20 PCS
 <p>M6x40</p>	 <p>M6x50</p>	 <p>M6x60</p>	 <p>Metal Gasket</p>	 <p>M6</p>
8 PCS	15 PCS	15 PCS	102 PCS	34 PCS
 <p>Screw Caps</p>	 <p>Nut Caps</p>	 <p>Hole Cover</p>	 <p>Universal wrench</p>	 <p>Open-end wrench</p>
102 PCS	34 PCS	6 PCS	1 PC	1 PC
Extra (Box A)				
 <p>M6x15</p>	 <p>M6x30</p>	 <p>M6x40</p>	 <p>M6x50</p>	 <p>M6x60</p>
4 PCS	2 PCS	2 PCS	2 PCS	2 PCS

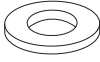
PART LIST



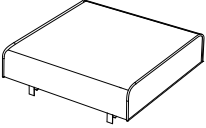
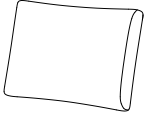

Extra (Box A)

(I)	(J)	(K)	(L)	(M)
				
Metal Gasket	M6	Screw Caps	Nut Caps	Hole Cover
4 PCS	2 PCS	4 PCS	2 PCS	1 PC

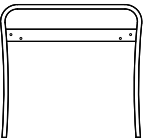
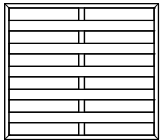
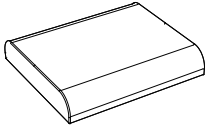

Parts List (Box B)

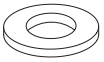
(F)	(G)			
				
Cushions	Pillows			
6 PCS	7 PCS			

Parts List (Box C)

(Q)	(R)	(S)	(H6)	(I)
				
Legs	Plates	Cushions	M6x25	Metal Gasket
4 PCS	2 PCS	2 PCS	16 PCS	16 PCS
(K)	(N)			
				
Screw Caps	Universal wrench			
16 PCS	1 PC			

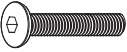
Extra (Box C)

(H6)	(I)	(K)		
				
M6x25	Metal Gasket	Screw Caps		
1 PC	1 PC	1 PC		

How To Assemble The Two-person Sofa

Step 1: Attach the base plate(C1) to the sofa backrest(D) with screws (H2).

NOTE: Do not tighten the screws all the way.

x5

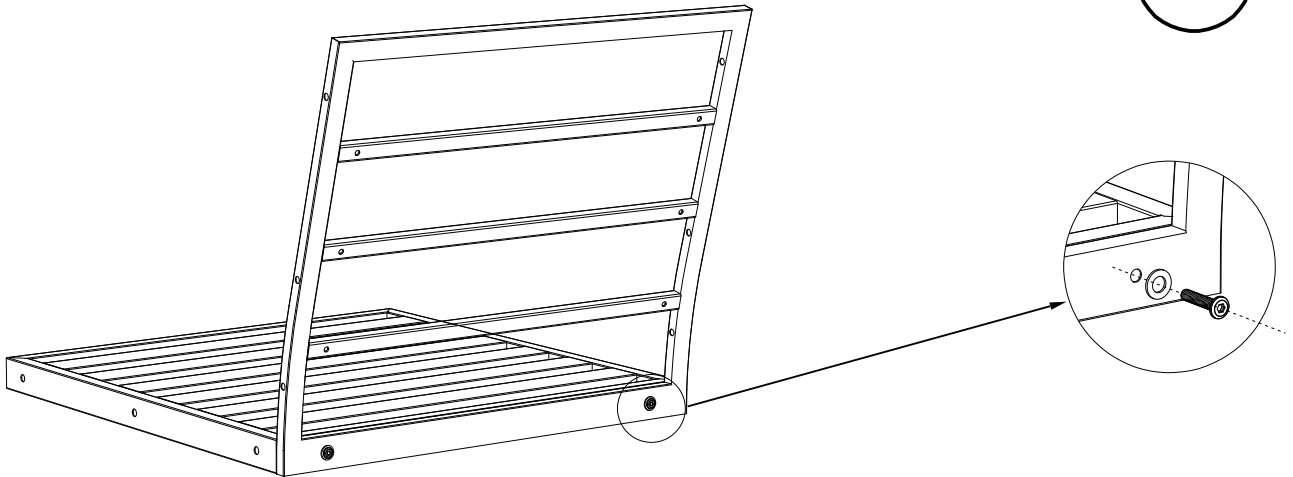

C1



x5

D



x5

H2  M6*30 x10

I  x10

Step 2: Connect the left and right sofa seat plates with screws(H4).
NOTE: Do not tighten the screws all the way.

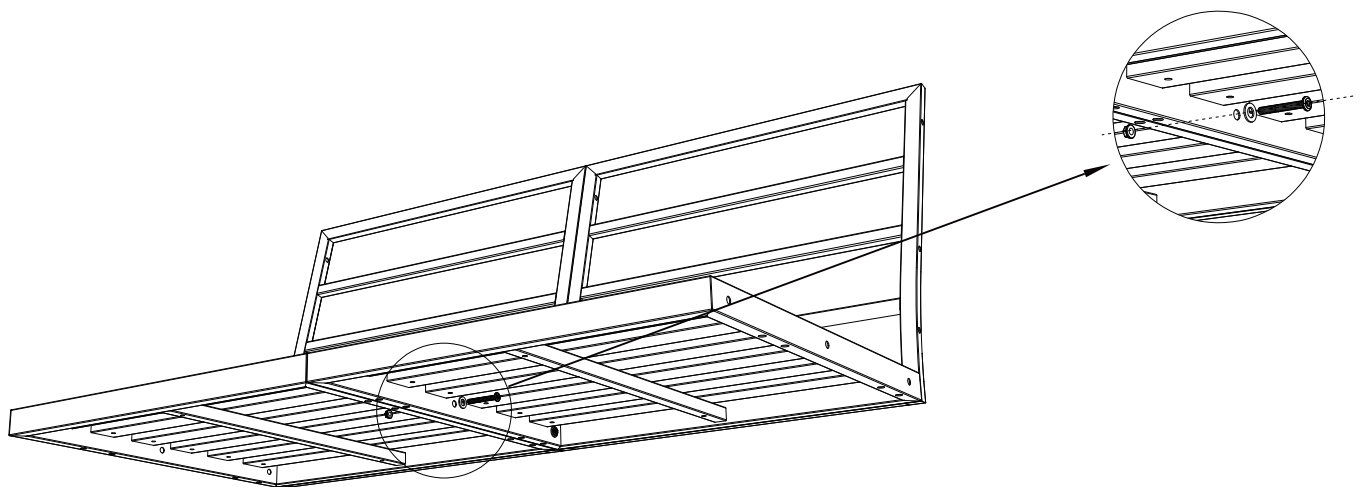

H4

 M6*50

x3 I



x3 J

 M6

x3

Installation steps

Step 3: Connect the left and right sofa backrests with screws(H5).
NOTE: Do not tighten the screws all the way.

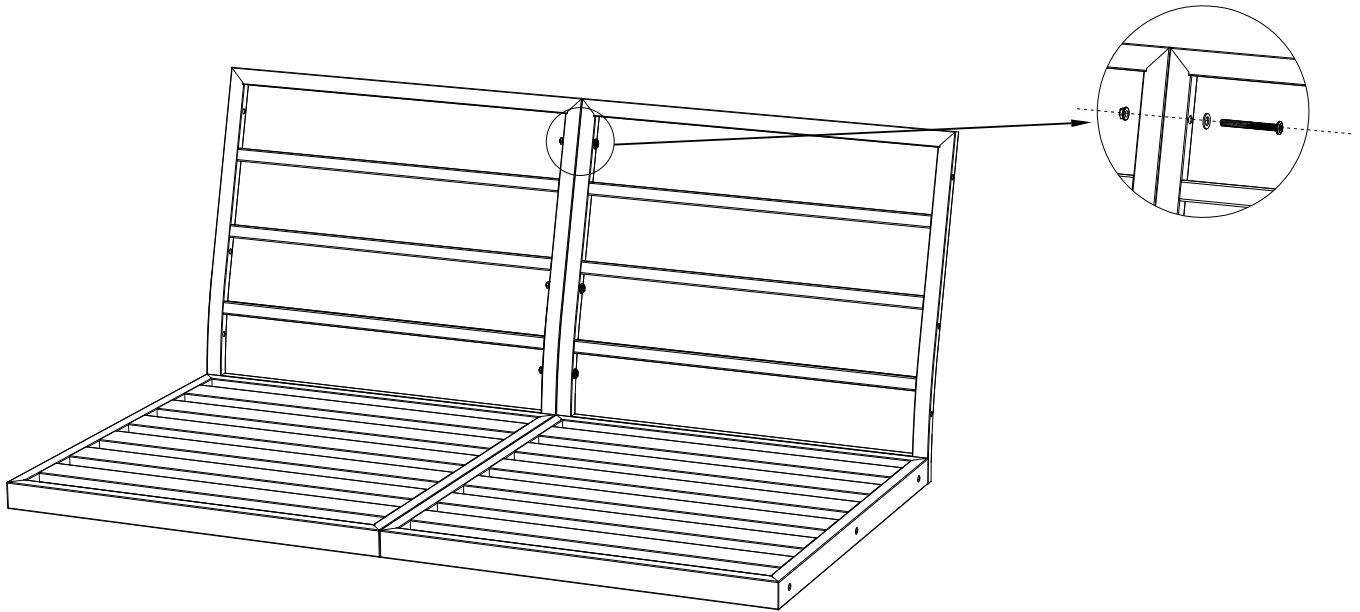

H5



M6*60

x3

I



x3

J



M6

x3

Step 4: Connect the left sofa armrest(A) of the sofa to the base plate (C1) and backrest(D) with screws(H2 and H3).

NOTE: Please tighten all screws.

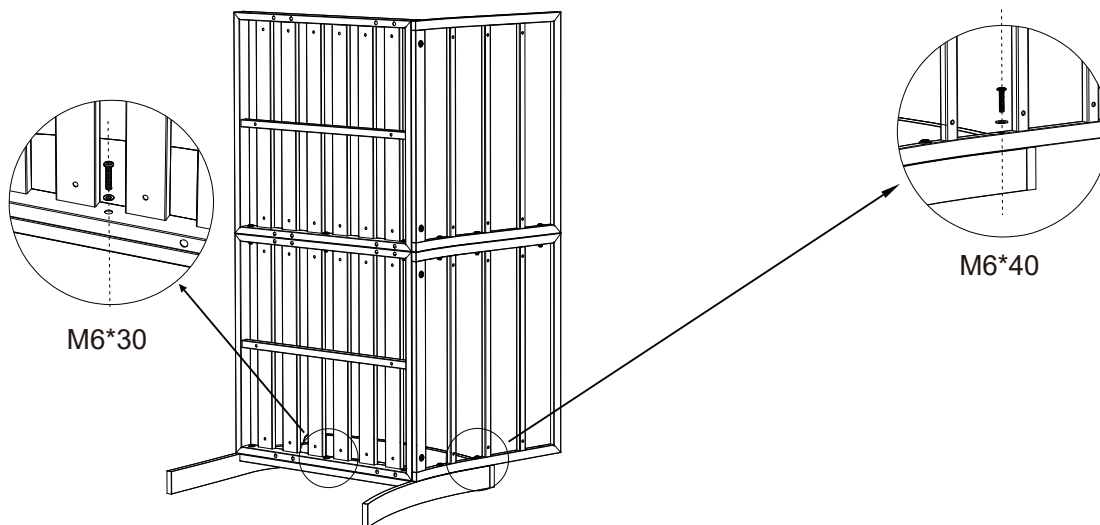

M6*30

M6*40

A

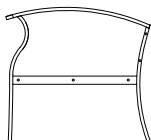

x1

H2



M6*30

x3

H3



M6*40

x2

I



x5

Installation steps

Step 5: Attach the sofa legs(E2) to the base plate(C1) with screws(H1).
NOTE: Please tighten all screws.

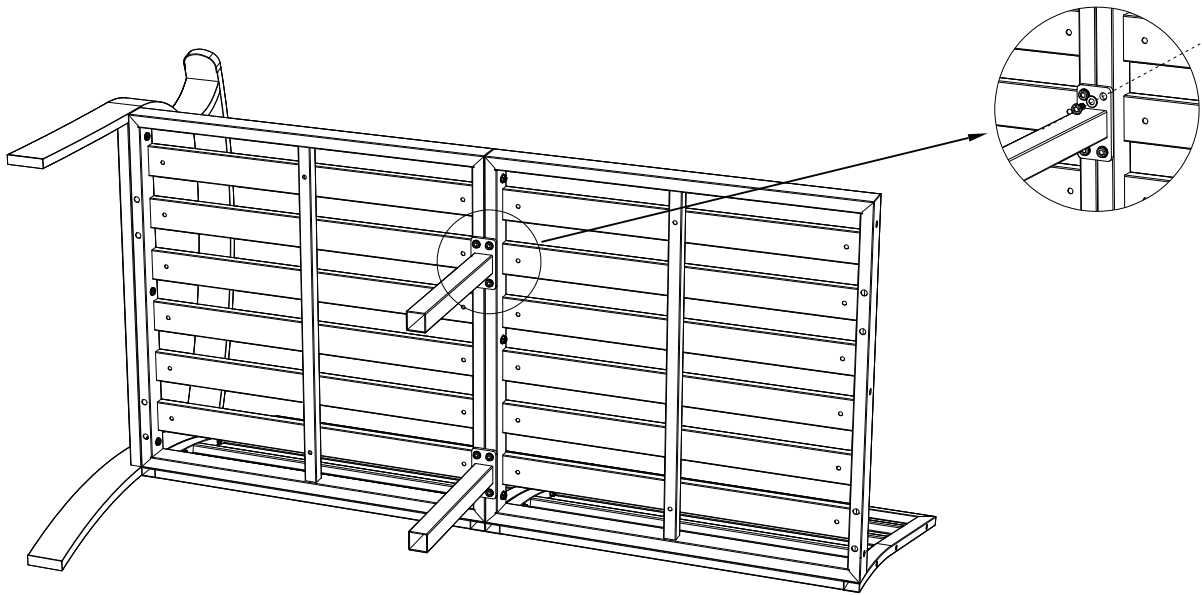

E2		x2	H1		M6*15	x8			x8
----	---	----	----	---	-------	----	--	---	----

Step 6: Attach the sofa legs(E2) to the base plate(C1) with screws(H1).
NOTE: Do not tighten the screws all the way.

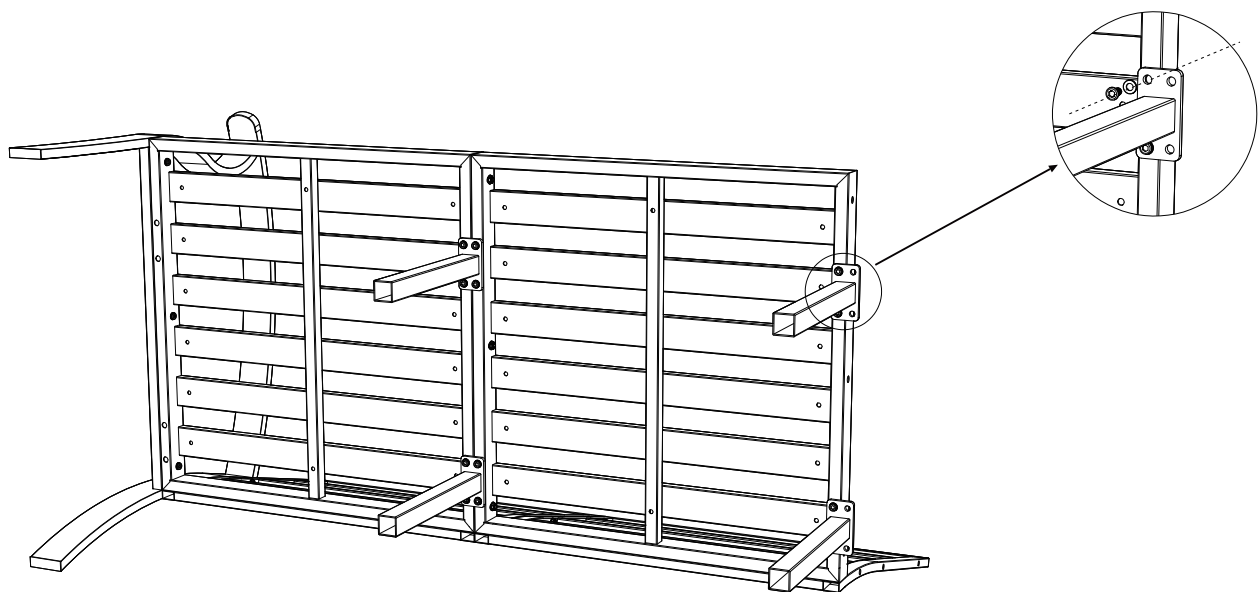

E2		x2	H1		M6*15	x4			x4
----	---	----	----	---	-------	----	--	---	----

How To Assemble The Three-person Sofa

Step 1: Connect the sofa seat plates with screws(H4).

NOTE: Do not tighten the screws all the way.

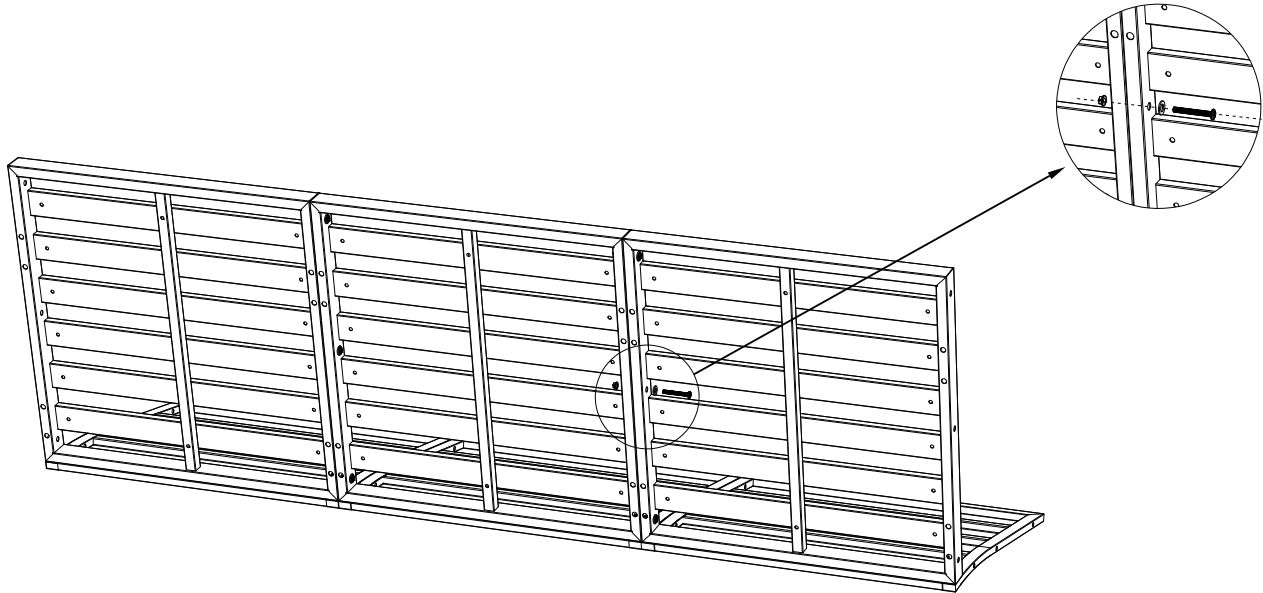

H4  M6*50 x6

I  x6

J  M6 x6

Step 2: Connect the sofa backrest with screws(H5).

NOTE: Do not tighten the screws all the way.

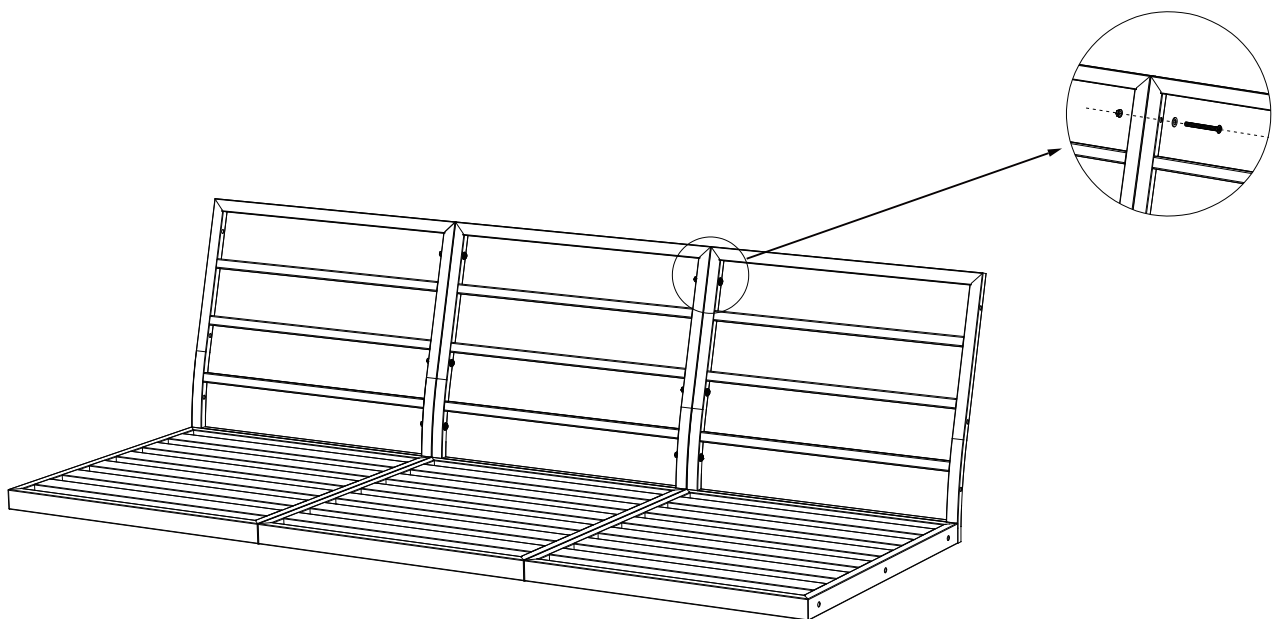

H5  M6*60 x6

I  x6

J  M6 x6

Installation steps

Step 3: Connect the right sofa armrest(B) of the sofa to the base plate (C1) with screws(H3).

NOTE: Do not tighten the screws all the way.

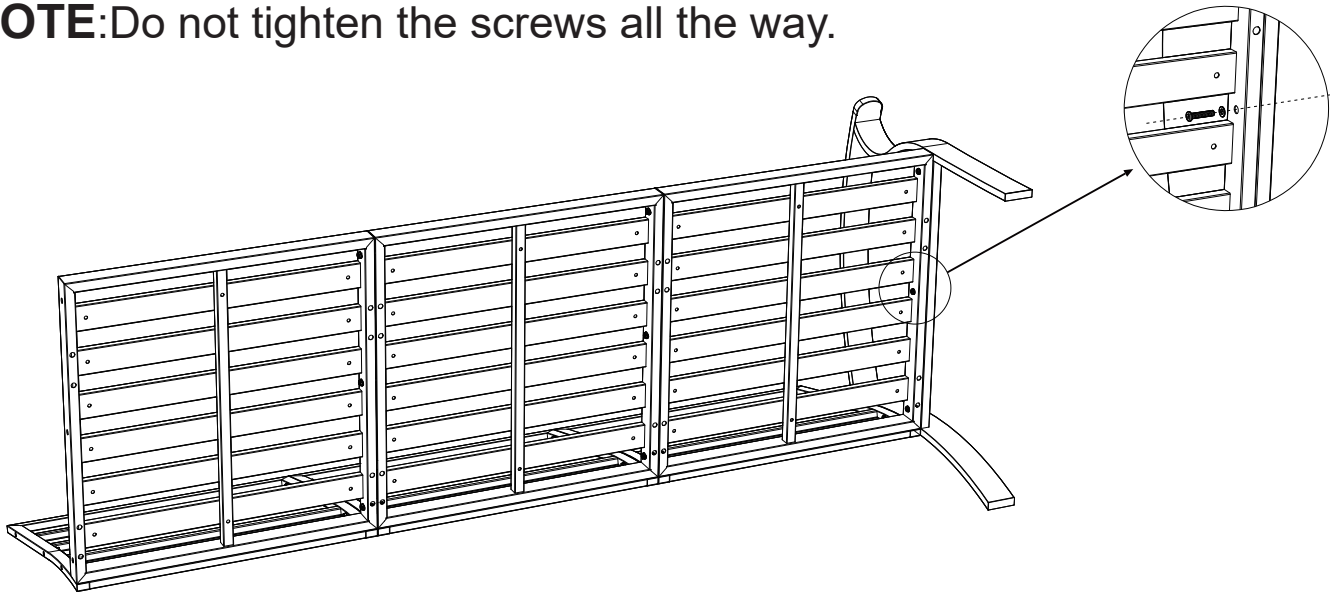

B		x1	H2	M6*30	x3
			I		x3

Step 4: Connect the left sofa armrest(A) of the sofa to the and backrest (D) with screws(H3).

NOTE: Please tighten all screws.

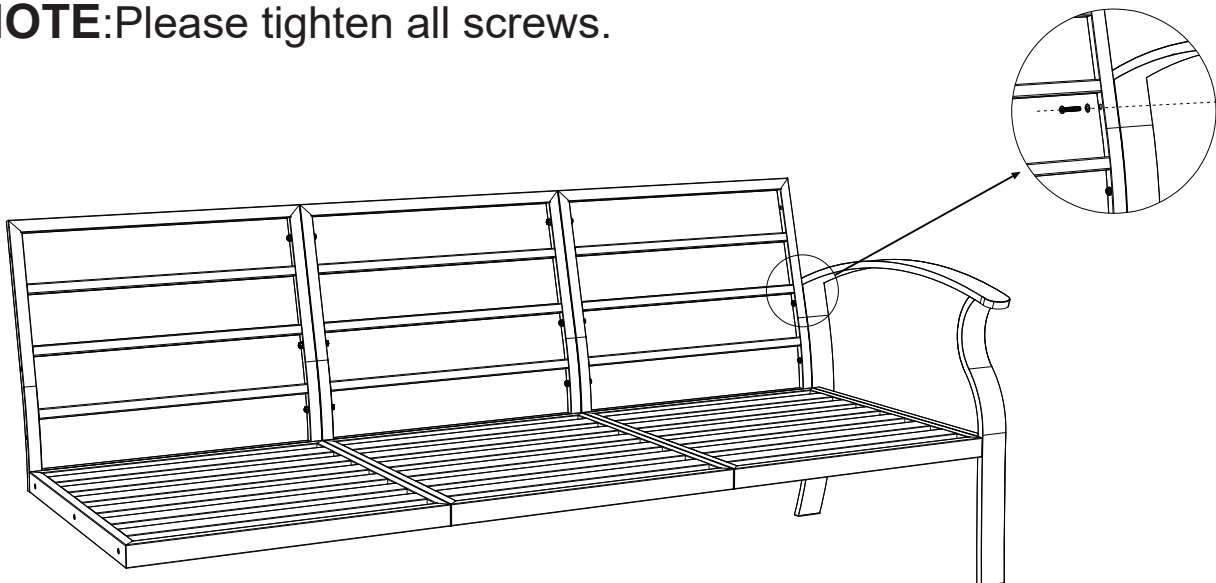



H3	M6*40	x2	I		x2
----	-------	----	---	--	----

Installation steps

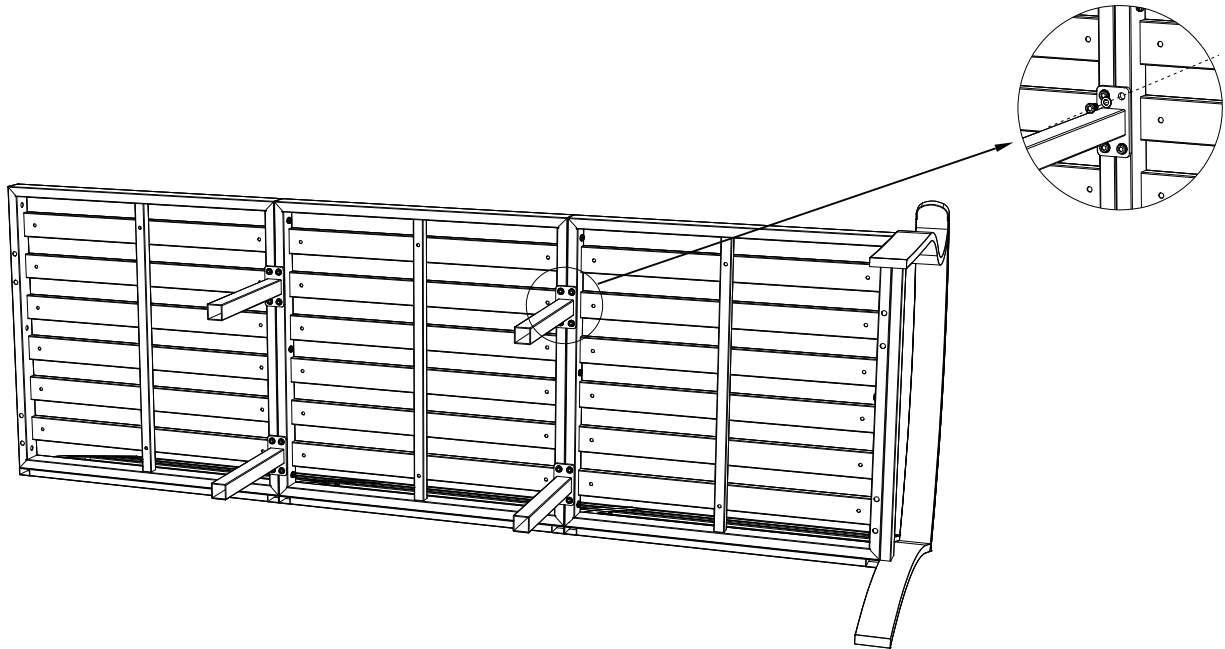

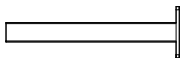
Step 5: Attach the sofa legs(E2) to the base plate(C1) with screws(H1).
NOTE: Please tighten all screws.

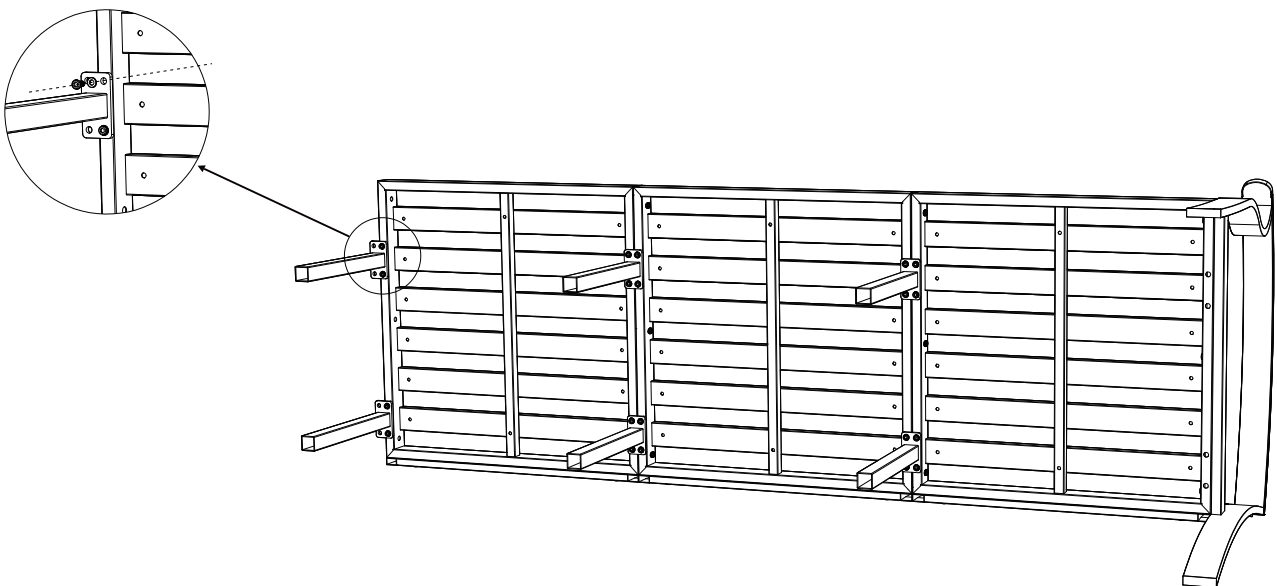

E2		x4	H1		M6*15	x16			x16
----	---	----	----	---	-------	-----	--	---	-----

Step 6: Attach the sofa legs(E2) to the base plate(C1) with screws(H1).
NOTE: Do not tighten the screws all the way.

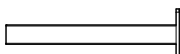

E2		x2	H1		M6*15	x4			x4
----	---	----	----	---	-------	----	--	---	----

How To Assemble The Corner Seat

Step 1: Attach the corner base plate (C2) to the sofa backrest (D) with screws (H2).

NOTE: Do not tighten the screws all the way.

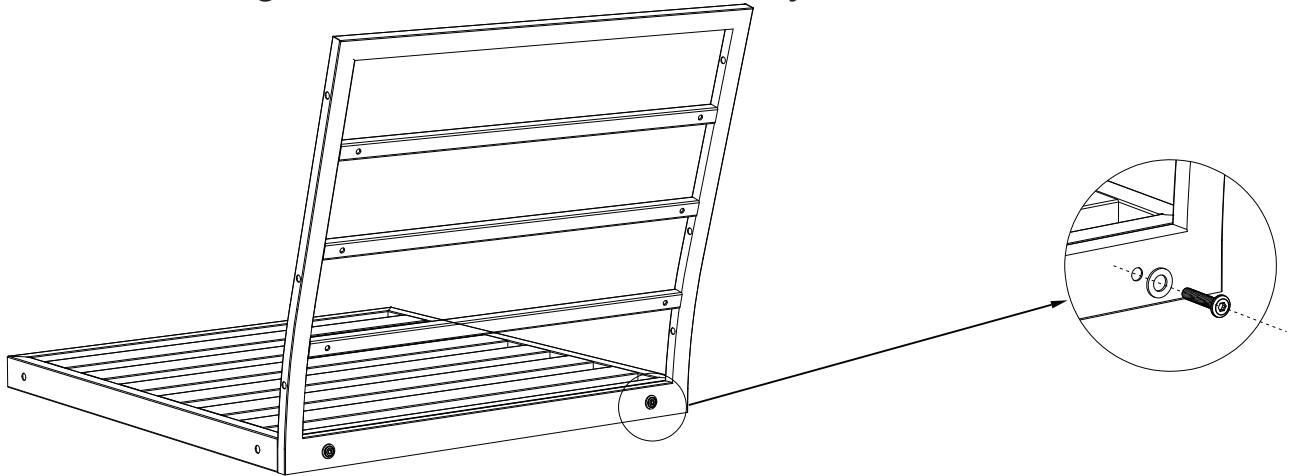

C2		x1	D		x1	H2		M6*30	x2
						I			x2

Step 2: Attach the corner base plate (C2) to the other sofa backrest (D) with screws (H2).

NOTE: Do not tighten the screws all the way.

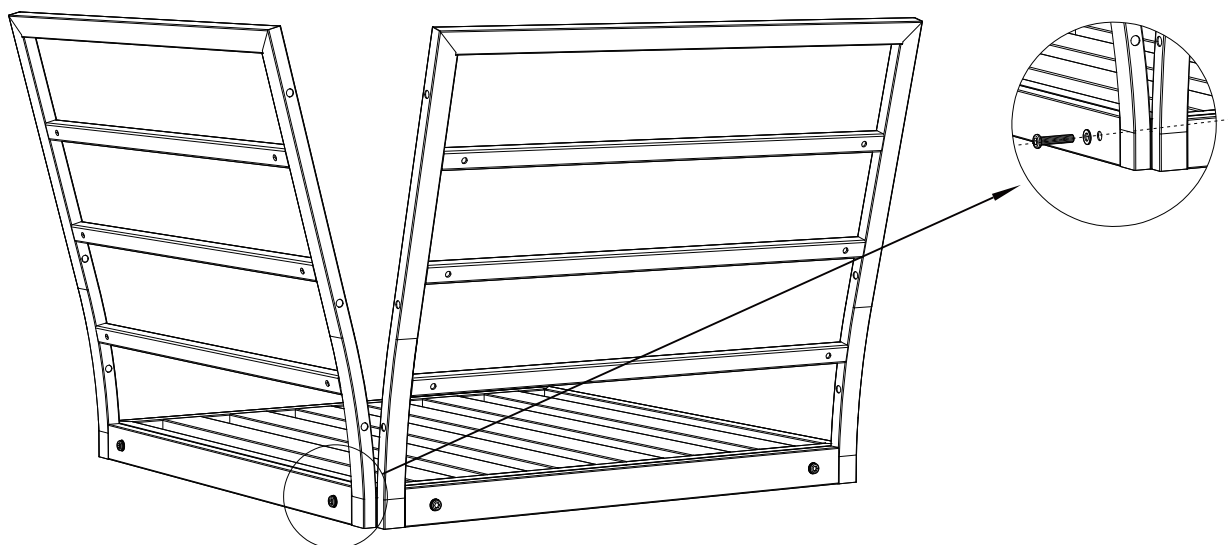





H2		M6*30	x2	I		x2
----	--	-------	----	---	--	----

Installation steps

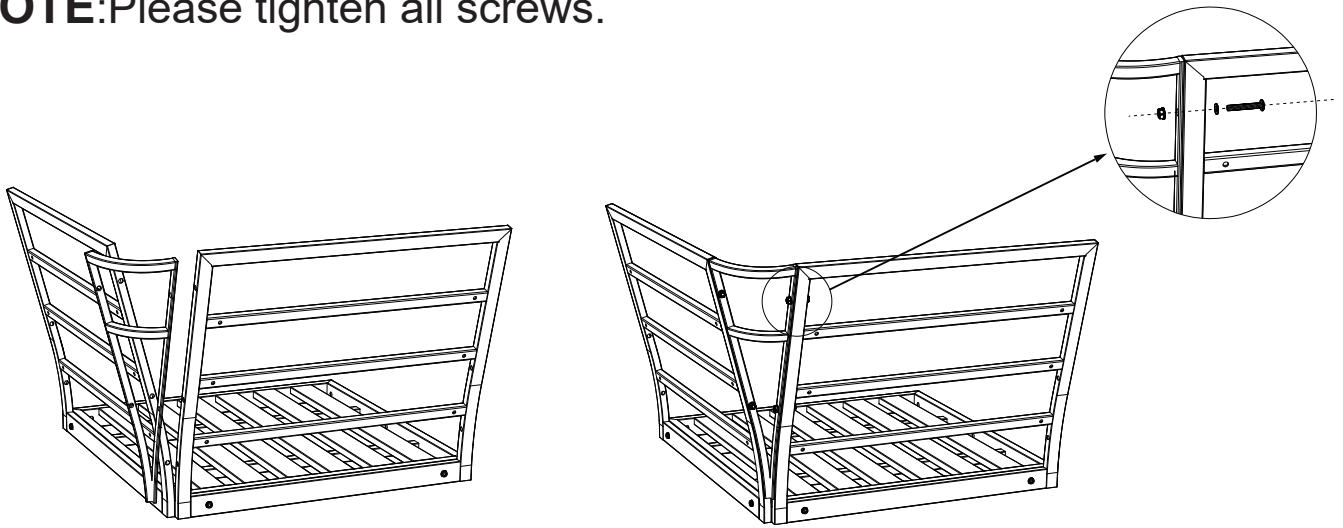
Step 3: Attach the corner connector (P) between the two backrests (D) with screws (H3).

NOTE: Please tighten all screws.



P		x1	H3	 M6*40	x4
J		x4	I		x4

Step 4: Attach the corner sofa legs (E1) to the corner sofa base (C2) with screws (H1).

NOTE: Please tighten all screws.

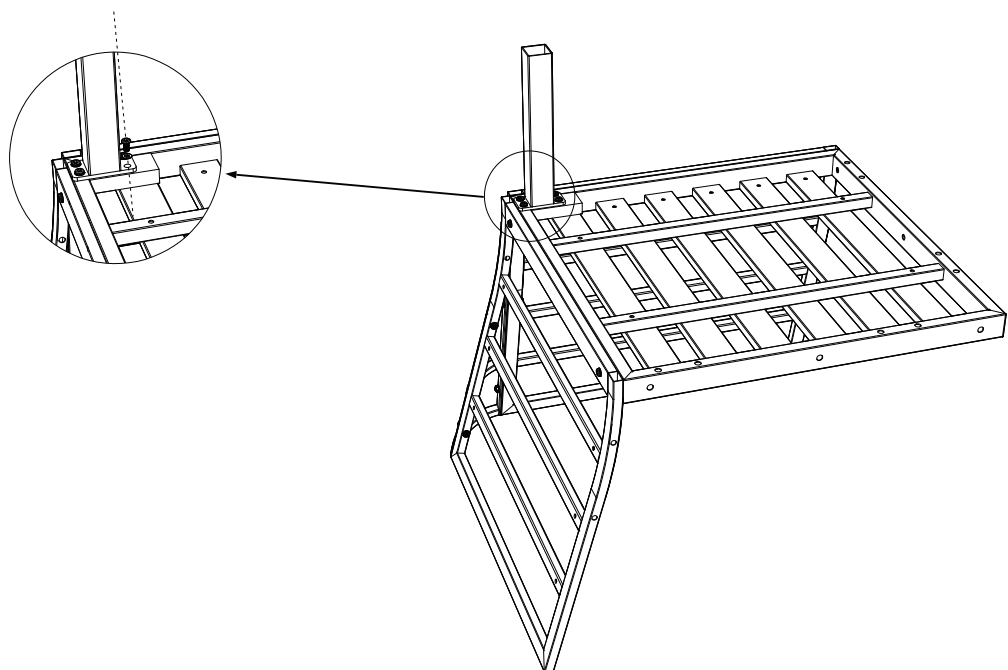

E1		x1	H1	 M6*15	x4	I		x4
----	---	----	----	---	----	---	---	----

Installation steps

Step 5: Attach the corner and three-seater sofas together and fix the sofa legs with screws(H1).

NOTE: Do not tighten the screws all the way.

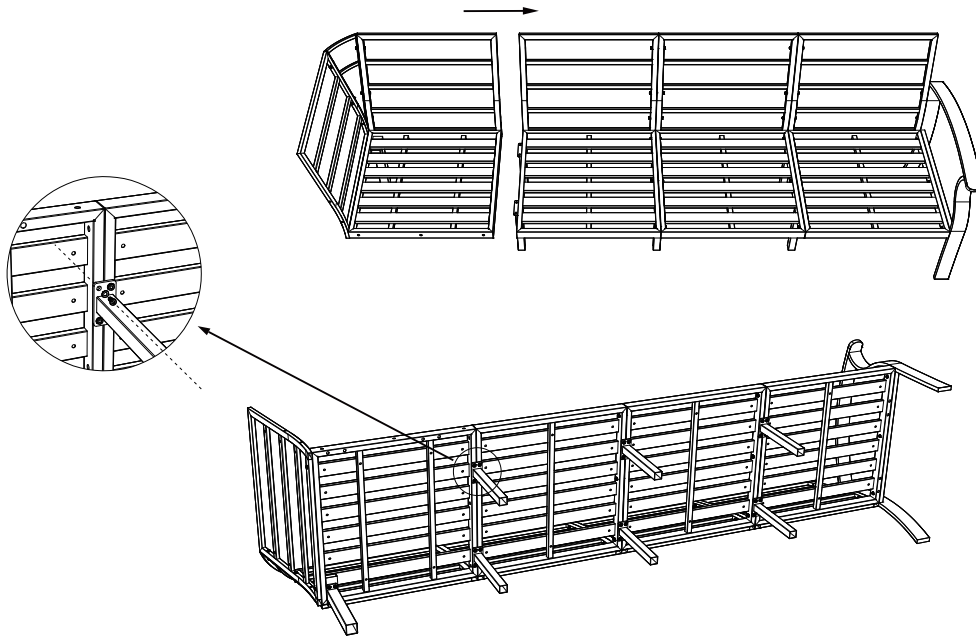

H1



x4

I



x4

Step 6: Attach the corner and three-seater sofas seat panels with screws(H4).

NOTE: Do not tighten the screws all the way.

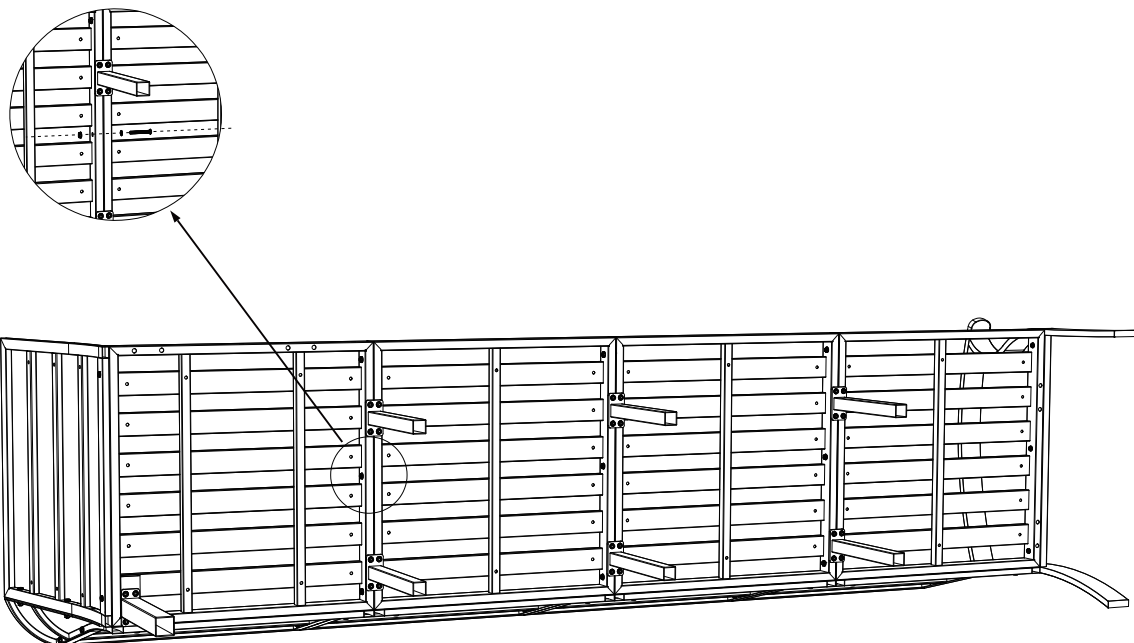

H4



x3

I



x3

J



x3

Installation steps

Step 7: Attach the backrests of the corner and three-seater sofas with screws(H5).

NOTE: Do not tighten the screws all the way.

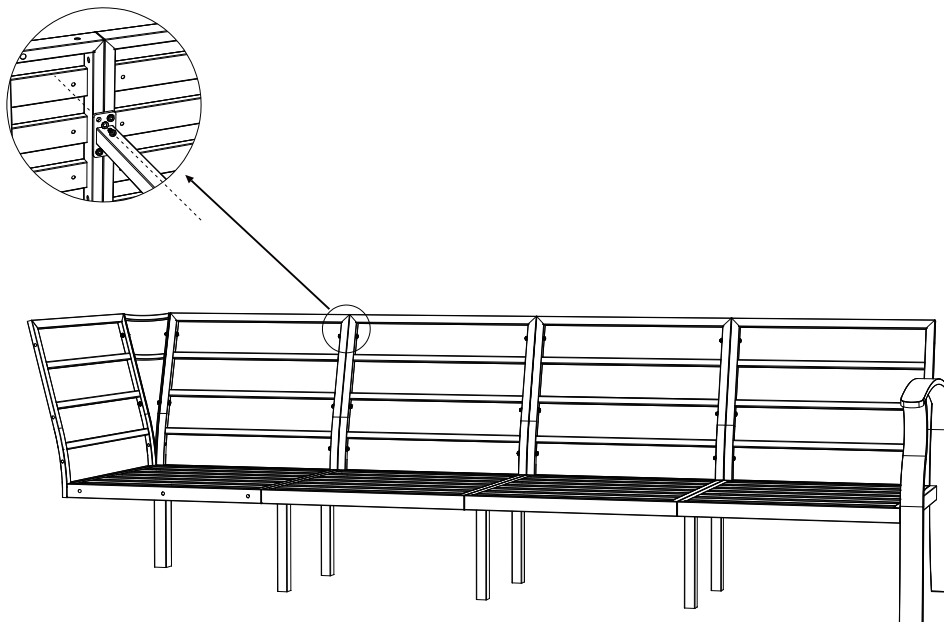

H5



M6*60

x3

I



x3

J



M6

x3

Step 8: Attach the corner and two-seater sofas together and fix the sofa legs with screws(H1).

NOTE: Do not tighten the screws all the way.

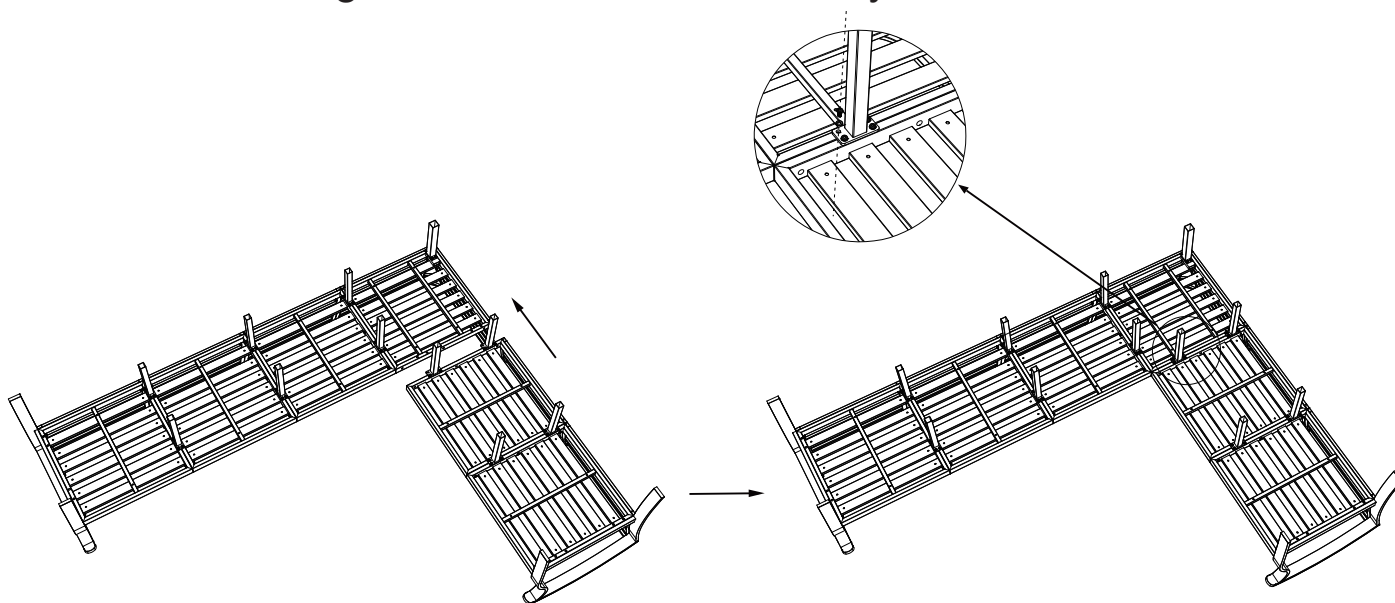

H1

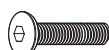

M6*15

x4

I



x4

Installation steps

Step 9: Attach the two-person and corner seat panels together with screws(H4).

NOTE: Do not tighten the screws all the way.

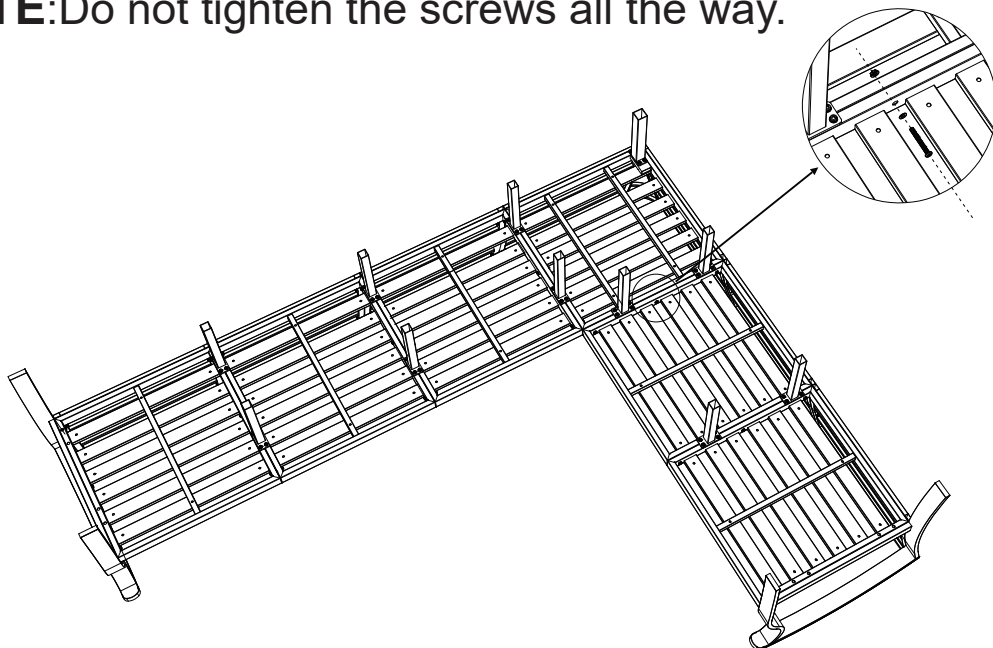

H4	 M6*50	x3	I		x3	J	 M6	x3
----	---	----	---	---	----	---	--	----

Step 10: Attach the backrests of the corner and three-seater sofas with screws(H5).

NOTE: Please tighten all screws.

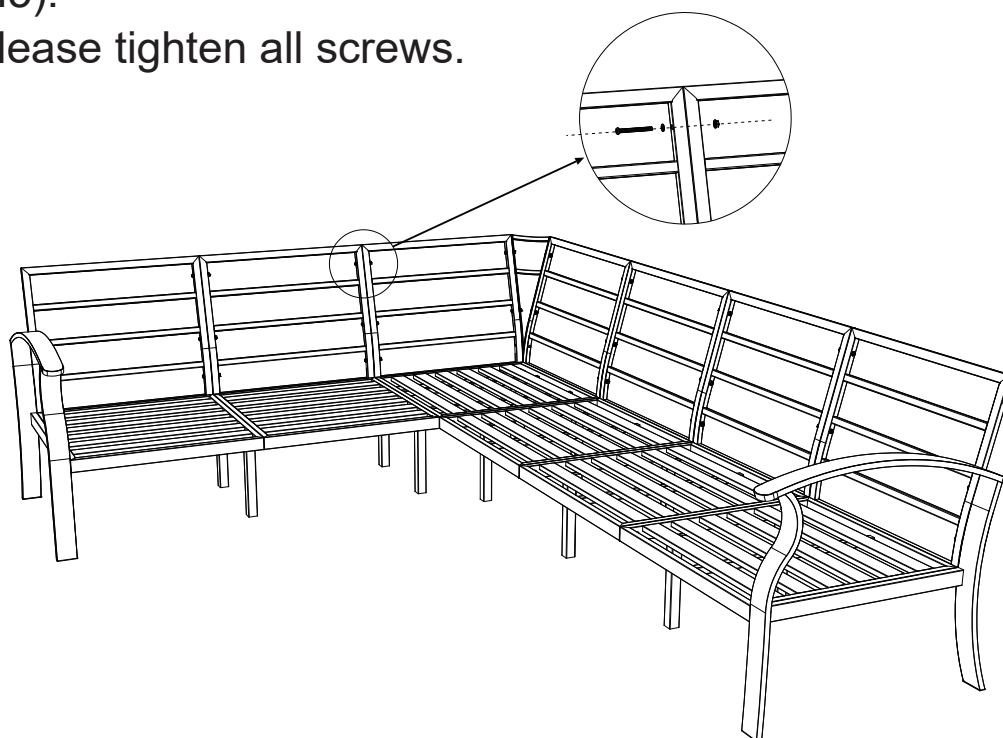

H5	 M6*60	x3	I		x3	J	 M6	x3
----	---	----	---	---	----	---	--	----

Installation steps

Step 11: Insert the hole cover (M) into the free screw hole above the backrest.

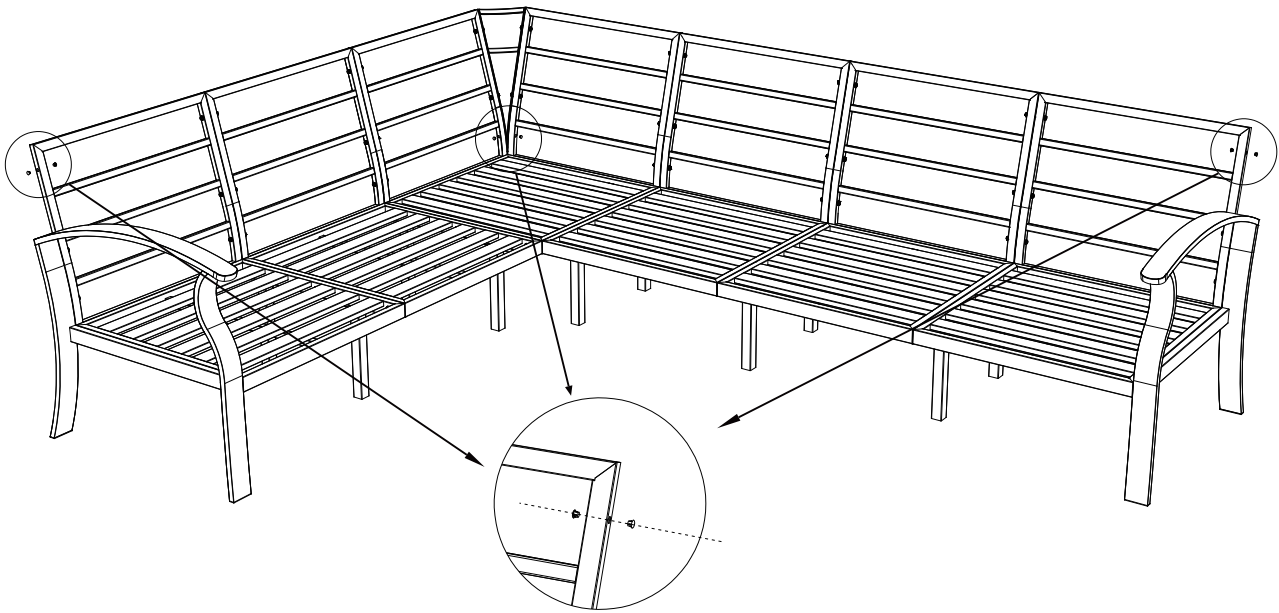

M



x6

Step 12: Put the screw cap (K) on the all screw and put the nut cap (L) on the nut.

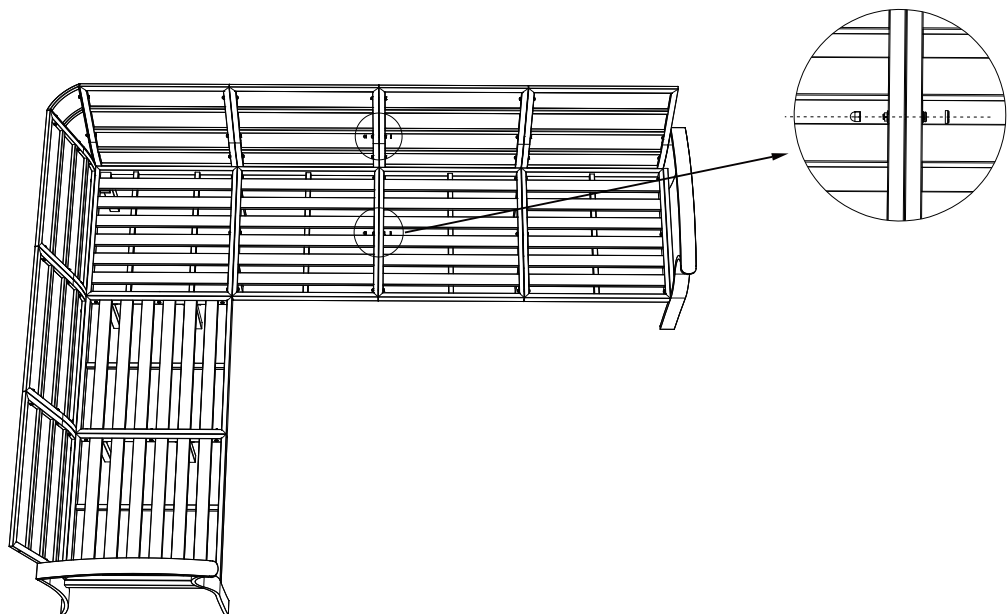

K



x102

L



x34

How To Use The Seat Cushions And Pillows

Step 1: Put the seat cushions(F) on the seat plate, stick the velcro under the seat cushions.

NOTE: Pay attention to the front and rear placement of the seat cushions.

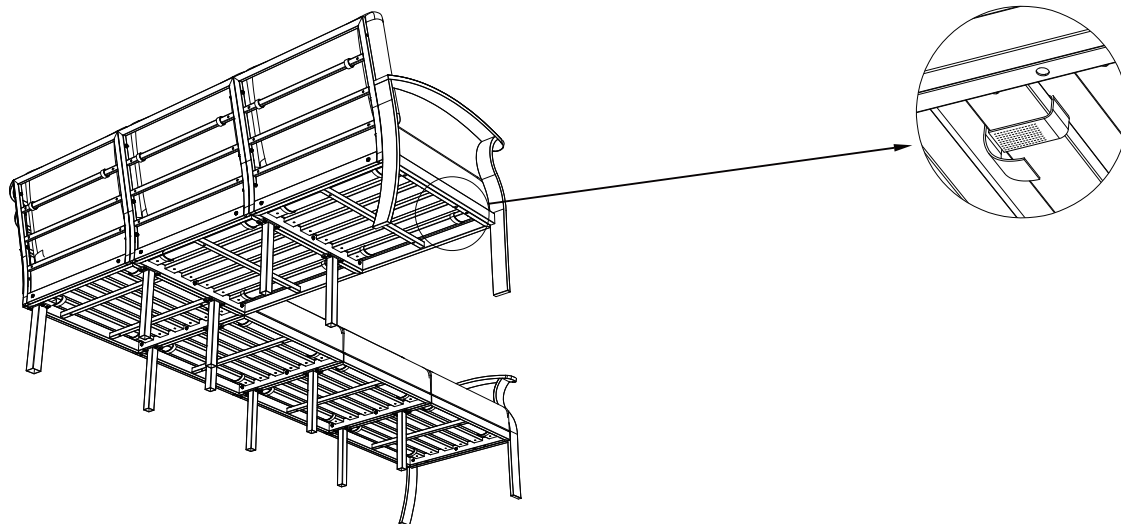

F

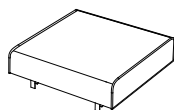

x6

Step 2: Put the pillows(G) on the backrest of the sofa and stick the velcro.

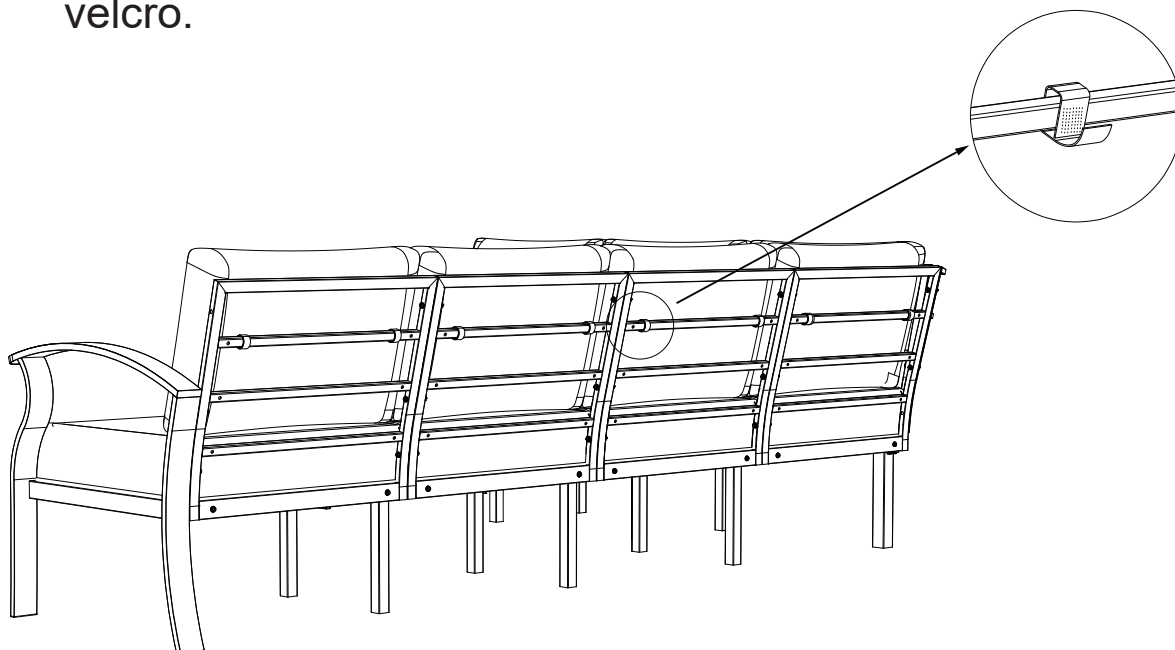

G





x7

How to Assemble The Footrest

Step 1: Connect the seat plate(R) and legs(Q) together with screws(H6).

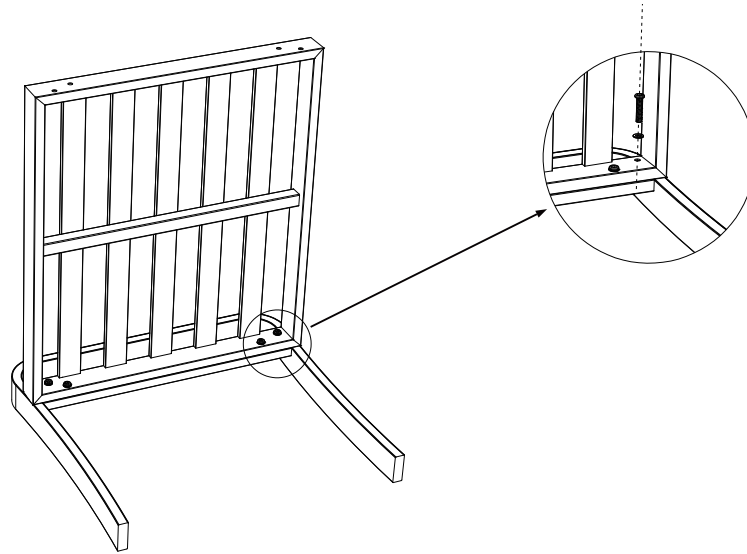
NOTE: Do not tighten the screws all the way.

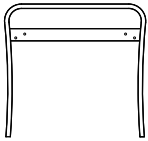
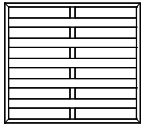



Q		x2	R		x2	H6		M6*25	x8
						I		x8	

Step 2: Connect the seat plate(R) and the other legs(Q) together with screws(H6).

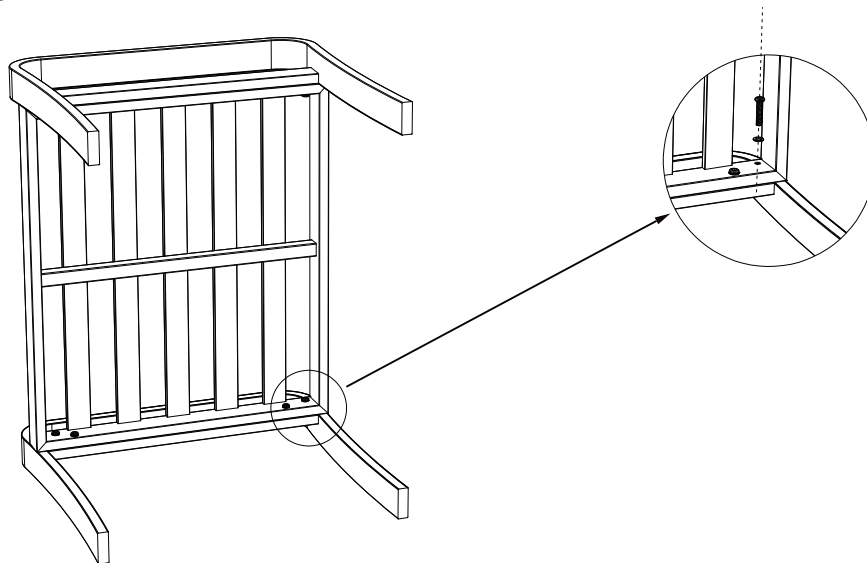
NOTE: Please tighten all screws.

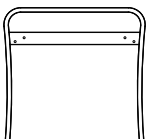

Q		x2	H6		M6*25	x8
			I		x8	

Installation steps

Step 3: Put the screw cap(K) on the screw.

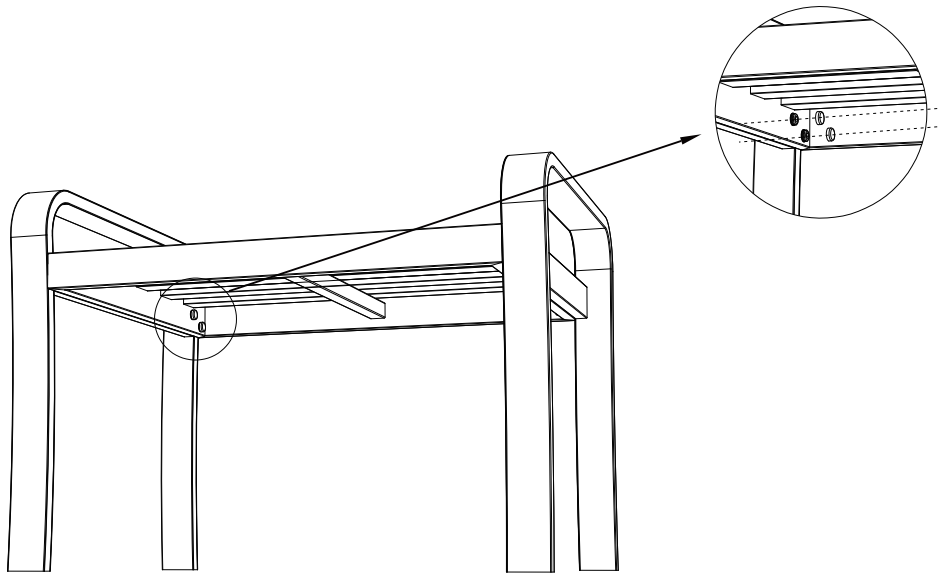

K  x16

Step 4: Put the cushions(S) on the seat plate, stick the velcro under the seat cushions.

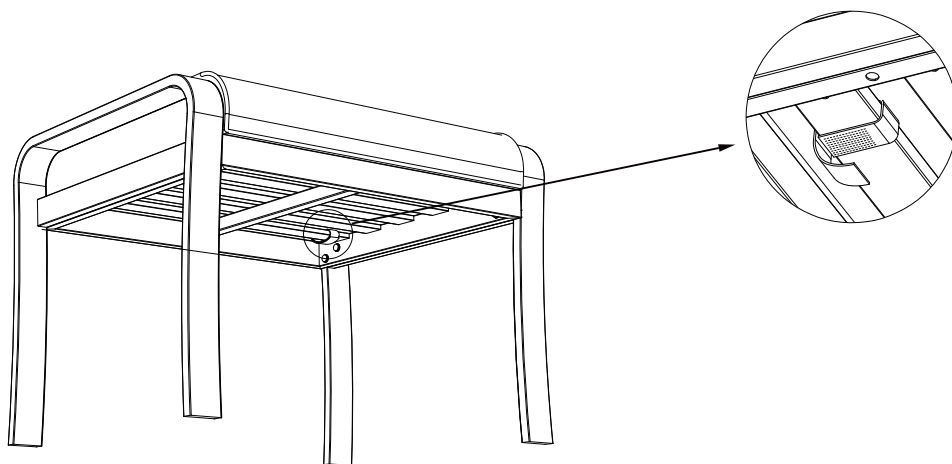

S  x2

Cushion Manual



7pcs white foam for seat cushion
7pcs PP cotton filler for back cushion



7pcs back cushion covers



7pcs seat cushion covers



Open cushion filler packing



Put the cushion filler inside the cover



Back Cushion



Open seat cushion
white foam packing



Put the white foam
inside the cover



Seat Cushion

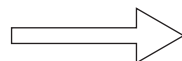

7pcs back cushions

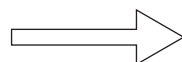

7pcs seat cushions

Please Note:

Because the cushion and pillow infilling is vacuum packed, So after you open the bag and put them into the covers, The springback of the PP cotton of pillow need some more time than the white foam cushion, usually need 3-4 days. It can make the time shorter if slapping the pillows with the palm or other flat object.