

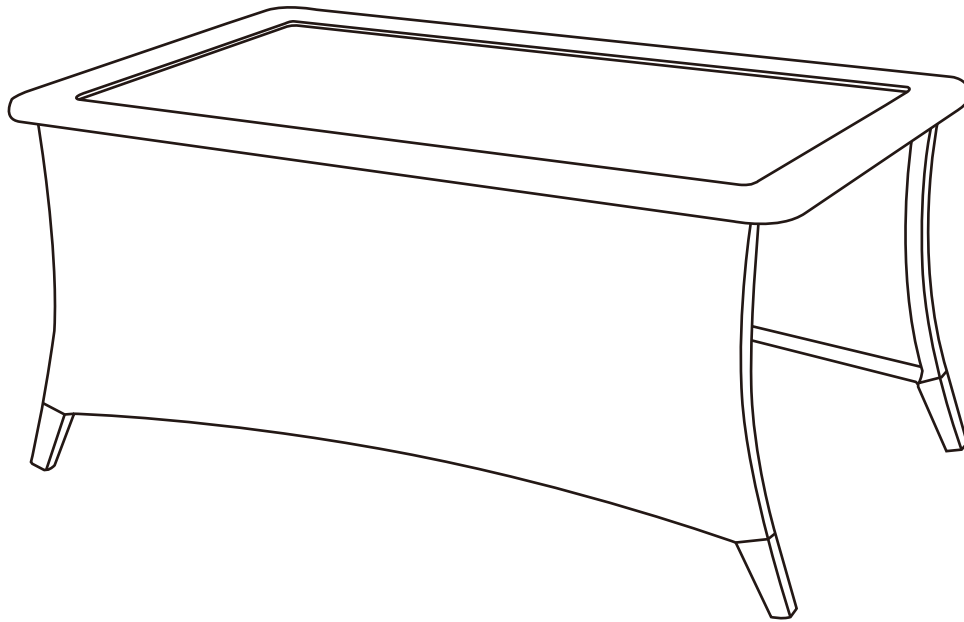





# INSTALLATION & ASSEMBLY

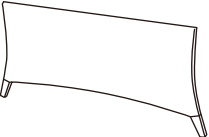

	PART LIST	DESCRIPTON	QTY
A		TOP	1
B		SIDE BOARD	2
C		SUPPORT FRAME	1
D		BOLT -- M6 x 20mm	4
E		BOLT -- M6 x 35mm	4
F		WASHER -- M6	8
G		HEX WRENCH	1

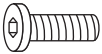
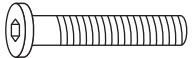
\* Don't fully tighten all the bolts till the very end!

**PRE-ASSEMBLY PREPARATION:**

--- Please read through the instructions before beginning assembly.

--- Clear out the space for assembly and lay out all of the parts based on the Parts List, extra room will allow you to easily determine if all the pieces are present.

--- Keep small parts and pieces away from children until fully assembled.

Step 1: Attach 2pcs side board (B) to table top (A) with 4 bolts (D) and 4 washers (F).

\* Do not fully tighten bolts until the entire frame is assembled.

Step 2: Attach support frame (C) to 2pcs side board (B) with 4pcs bolts (E) and 4 washers (F).

Turn over the assembled table. Verify the alignment and adjust, now fully tighten all the bolts using Hex Wrench (G)

