

# ASSEMBLY INSTRUCTIONS

---

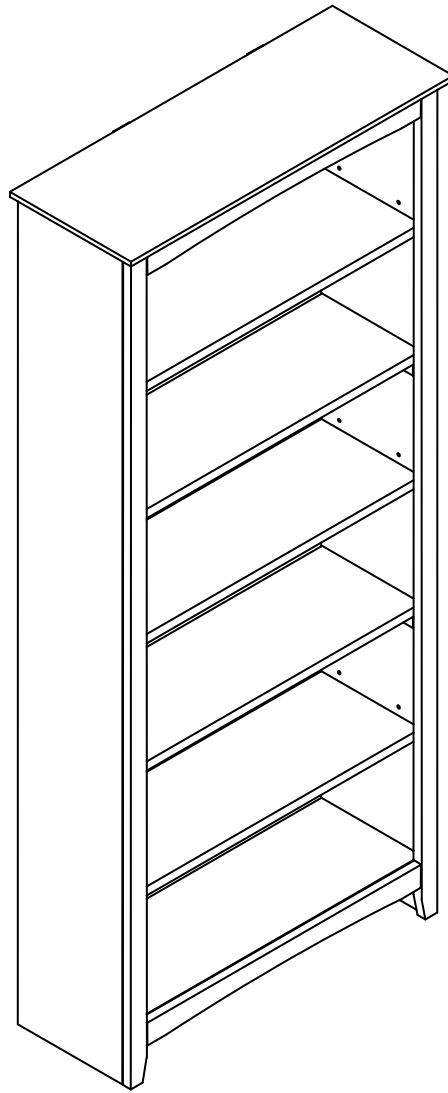

---

Description : 32 X 12 X 72 HIGH BOOK CASE RTA

Printed in Vietnam

## BEFORE ASSEMBLY

Thank you for purchasing this quality product. This product has been designed for easy assembly and constructed for durability. All parts were checked prior to packaging to insure quality. Prior to beginning assembly, however, make sure all parts and hardware are included and free of obvious defect. If a part is missing or defective, please contact the store where purchased. If hardware is missing, or you need help with assembly, please call toll free.

### IMPORTANT NOTE:

- Place all wooden parts on a clean and smooth surface such as a rug or carpet to avoid the parts from being scratched.
- Remove all wrapping material, including staples & packing straps before you start to assemble.
- DO NOT tighten all screws and bolts until completely assembled.
- Keep all hardware parts out of reach of children.

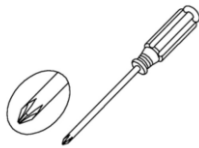

### ASSEMBLY TOOLS REQUIRED

NOT INCLUDED





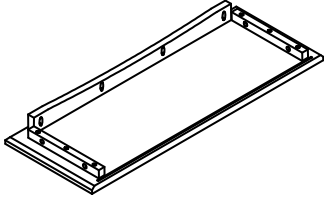
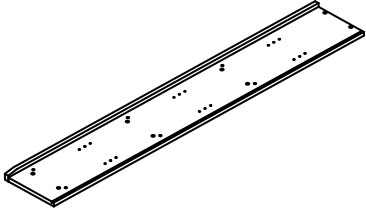
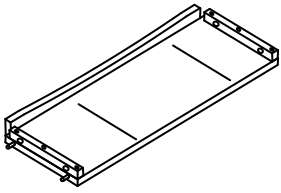
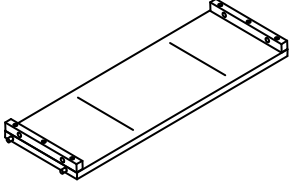
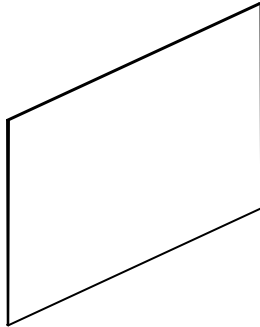
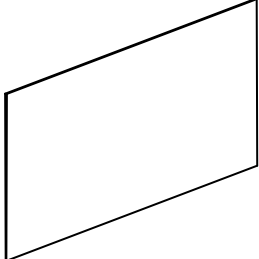
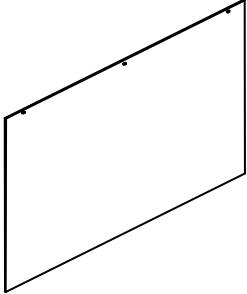

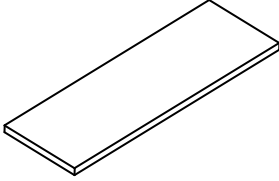

# PARTS LIST

When unpacking, please be careful not to discard any parts with the packaging. Before continuing, please make sure you have all of the following parts:

NO	Description	Q'ty	Sketch	NO	Description	Q'ty	Sketch
A	Top	1		B	Side panel (L-R)	2	
C	Bottom panel	1		D	Shelf panel	2	
E	Back upper (Large)	1		F	Back center (Small)	1	
G	Back lower (Small)	1		H	Connector	2	
I	Adjustable shelf	3					

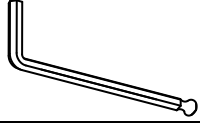
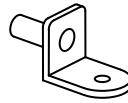
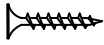
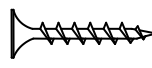
# HARDWARE LIST

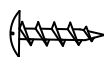
When unpacking, please be careful not to discard any parts with the packaging. Before continuing, please make sure you have all of the following hardware:

NO	Description	Q'ty	Sketch	NO	Description	Q'ty	Sketch
1	Bolt (M6 x 30mm)	16		2	Lock washer (Φ6.5 x 11mm)	16	
3	Flat washer (Φ6.5 x 13mm)	16		4	Allen Key (M4 x 110mm)	1	
5	Shelf support bracket	12		6	Short screw M3.5 x 15mm	16	
7	Long screw (M4 x 30mm)	2		8	Steel band	2	
9	Medium screw (M4 x 20mm)	17		10	Flat washer (Φ6.5 x 19mm)	6	

## STEP 1

Attach side panels (B) to the top (A), and shelf panels (D) and bottom panel (C) with bolts (1), and washers (2) and (3) as shown below. Tighten with Allen key (4).

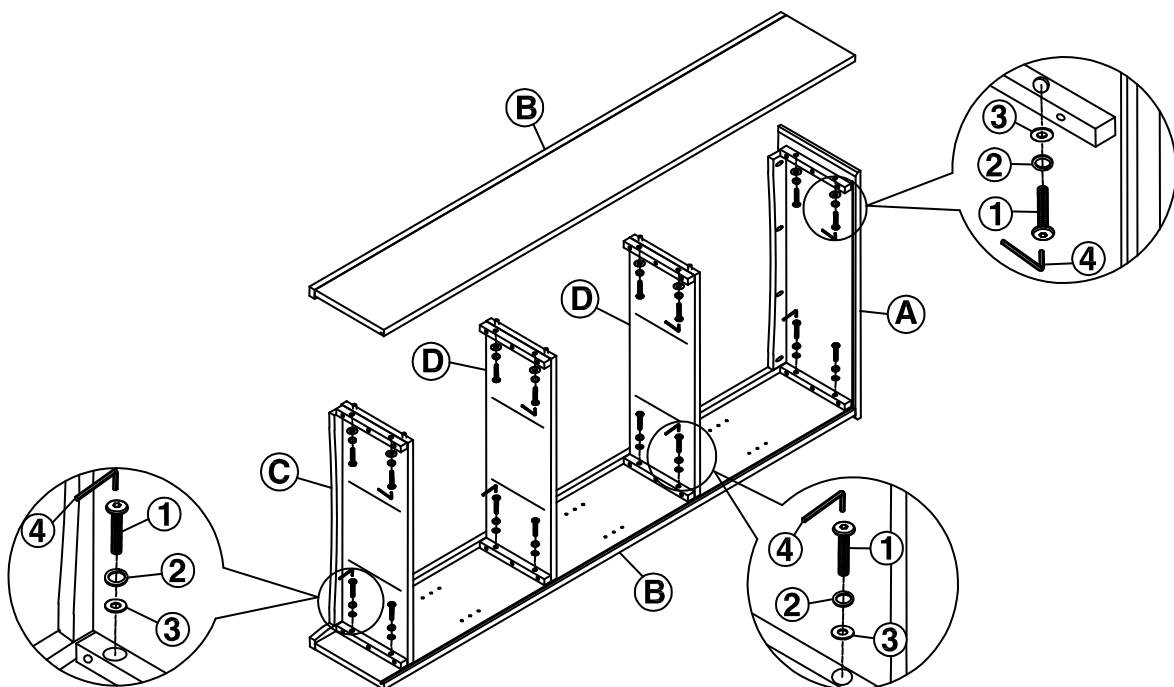

Printed in Vietnam

## STEP 2

Slide back panels (E), and (F) and (G) into the grooves as shown below .

Attach back panel (G) to bottom panel (C) with pan head screws (9). Then attach back panels (E), and (F) and (G) to shelf panels (D) with pan head screws (9) and washers (10) as shown below.

Tighten with a screwdriver.

Remove the paper strip and attach sticky side of connectors (H) to back of the unit. Then attach connectors (H) to the top (A), and bottom panel (C) and shelf panels (D) with pan head screws (9) as shown below. Tighten with a screwdriver.

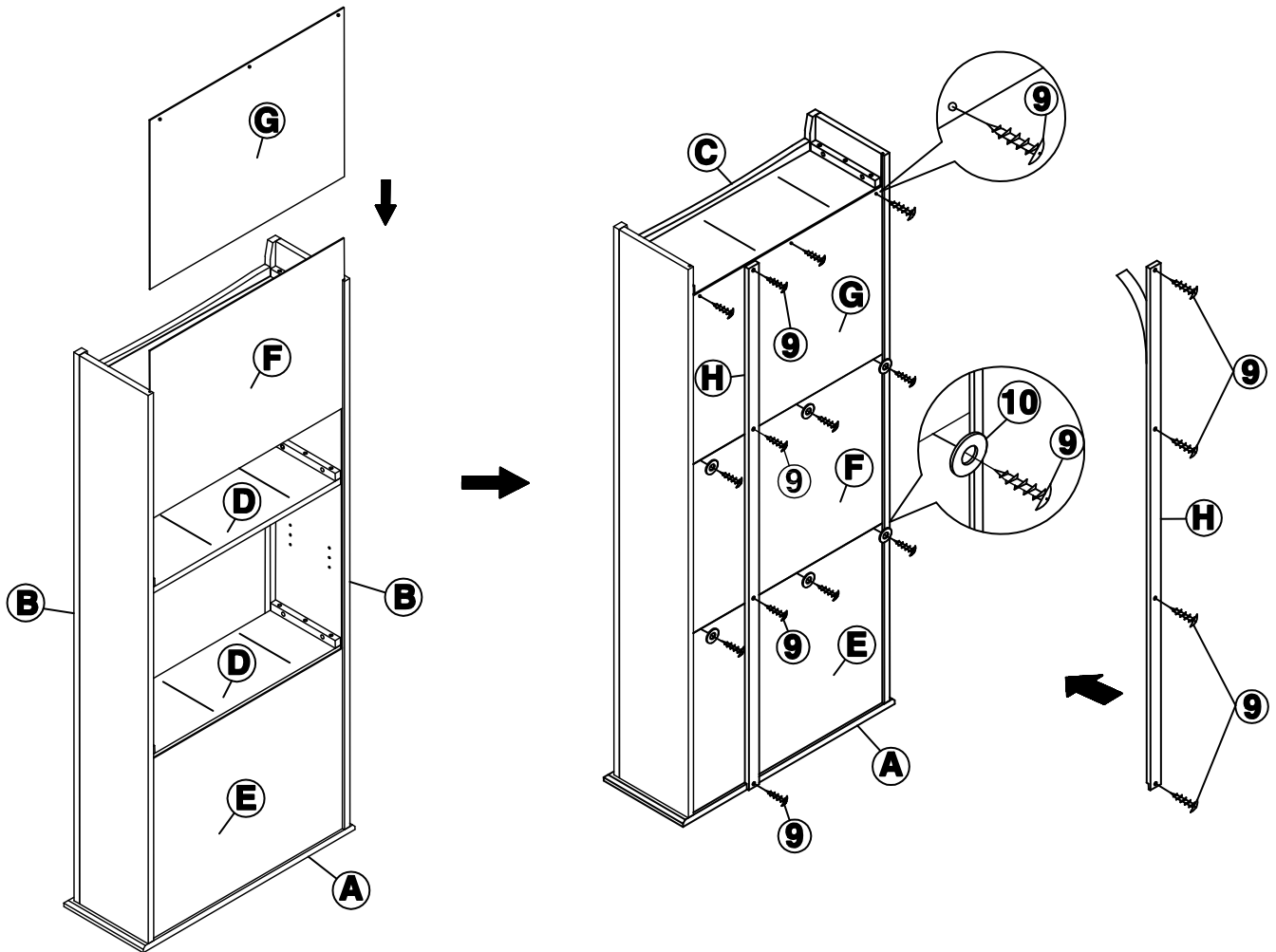

## STEP 3

Attach brackets (5) to the unit as shown below. Then place the shelves (I) on the brackets and attach with screws (6). Tighten with a screwdriver.

Attach steel bands (8) to the unit with screws (6). Then attach the steel bands to a wall with screws (7) as shown below (to secure the product and prevent tipping). Tighten with a screwdriver.

