

ATTENTION

PLEASE READ BEFORE OPENING + ASSEMBLING

WE STAND BEHIND OUR PRODUCTS 100%

YOUR SATISFACTION IS OUR #1 GOAL.

IF YOUR ORDER IS NOT PERFECT, OR IF YOU WOULD LIKE ANY ASSISTANCE; PLEASE FEEL FREE TO CONTACT US:

WE ARE HAPPY TO HELP!

LADDER FOR BUNK BED
ECHELLE POUR LIT SUPERPOSÉ
ESCALERA PARA LITERA

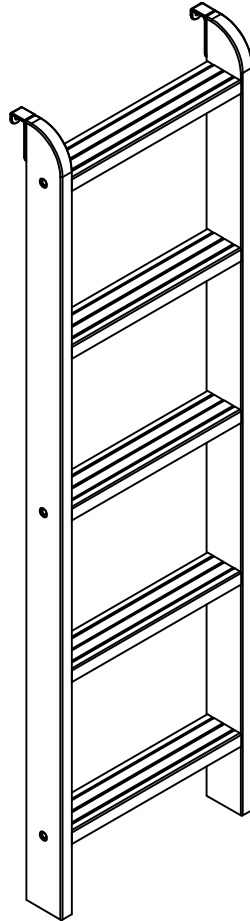

A

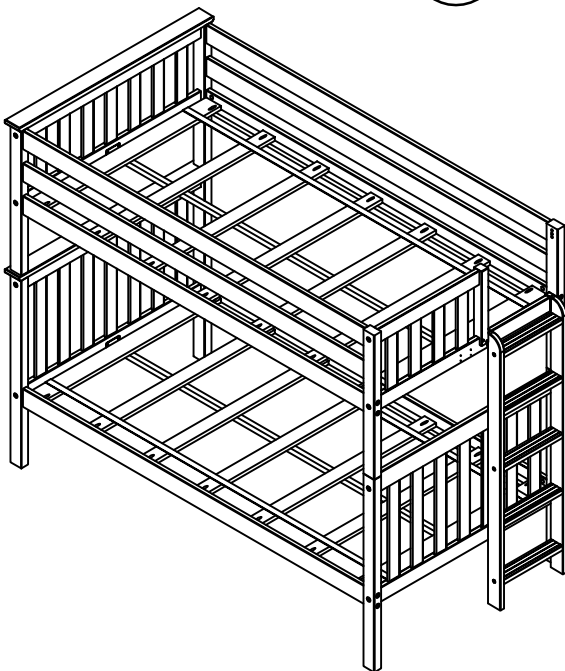

B

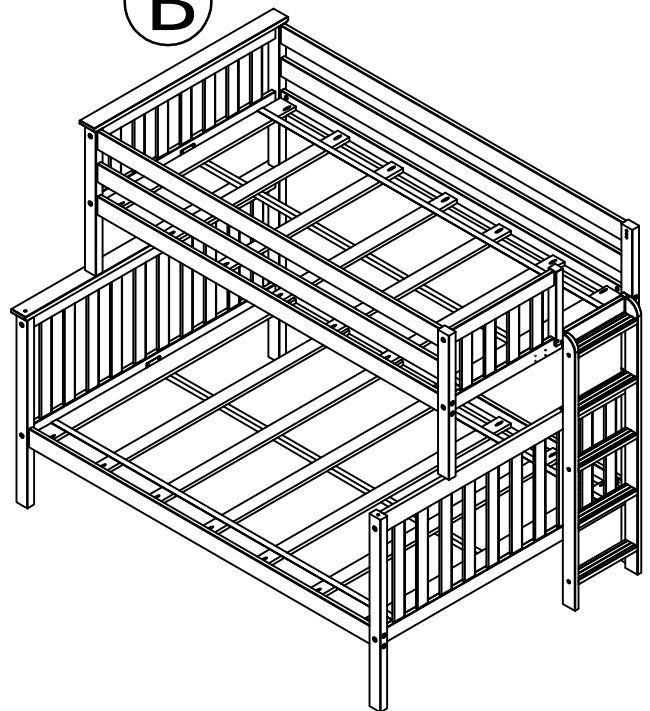

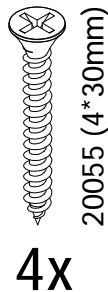
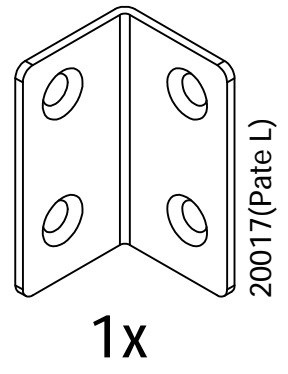
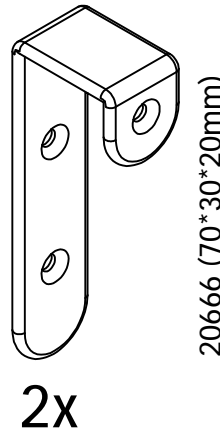
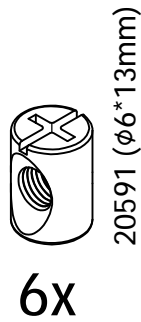
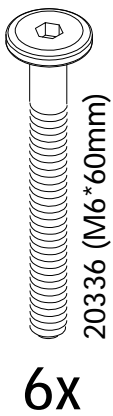
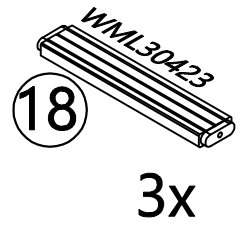
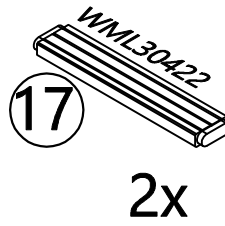
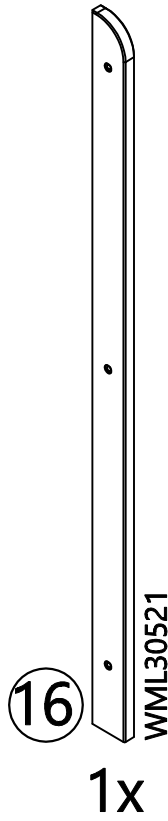
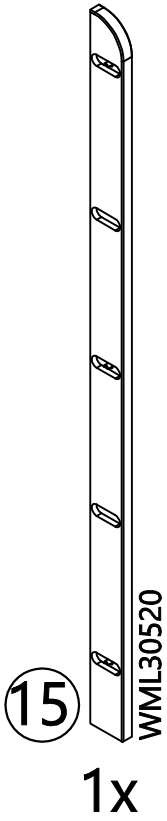

⚠ WARNING:

CHOKING HAZARD
Small Parts
Not for children under 3 years.
To be Assembled by an Adult

⚠ ATTENTION:

RISQUE D'ÉTOUFFEMENT
Petites parties
Ne convient pas aux enfants de moins de 3 ans.
Doit être assemblé par un adulte

⚠ ADVERTENCIA

PELIGRO DE ASFIXIA
Partes pequeñas
No apta para niños menores de 3 años
A ser ensamblado por un adulto

Not Included
Non Inclus
No Incluido

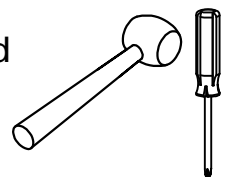

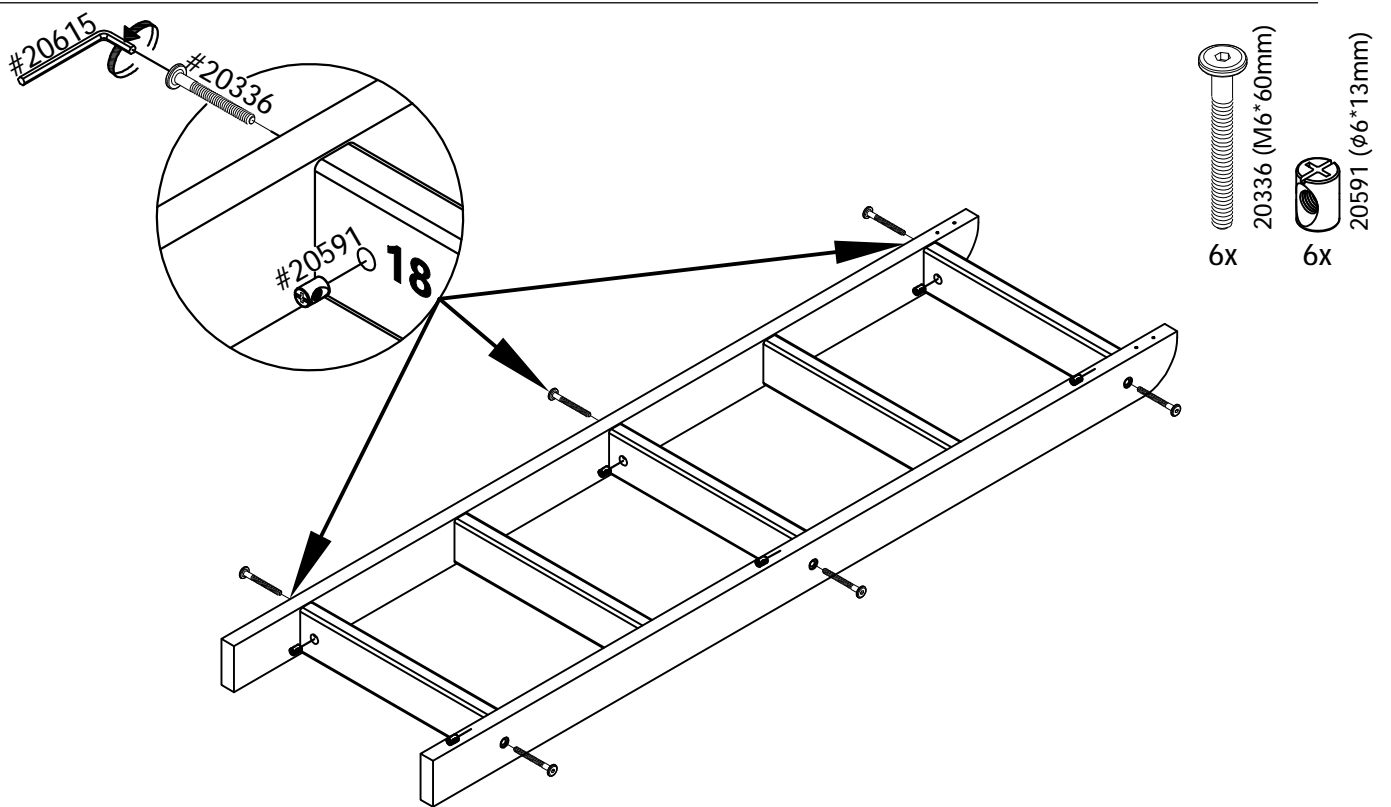
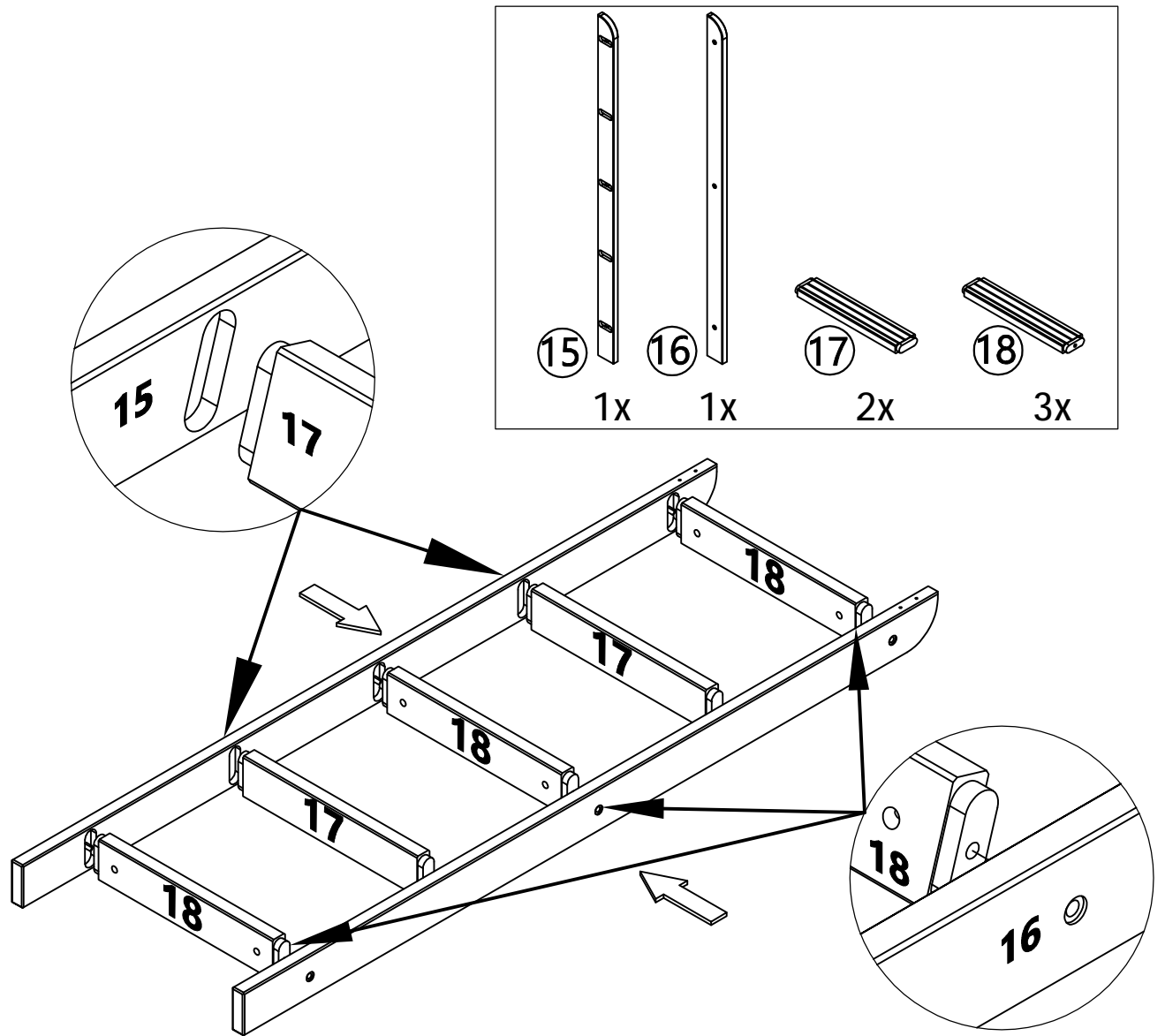

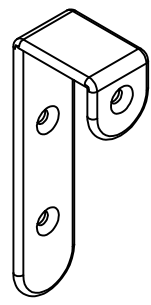
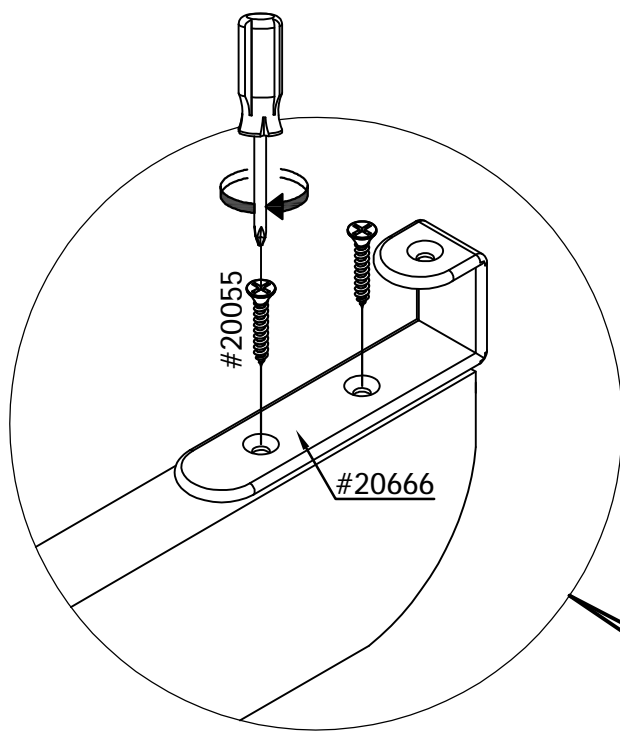

2x

20666 (70*30*20mm)



4x

20055 (4*30mm)



20012 (3*19mm)

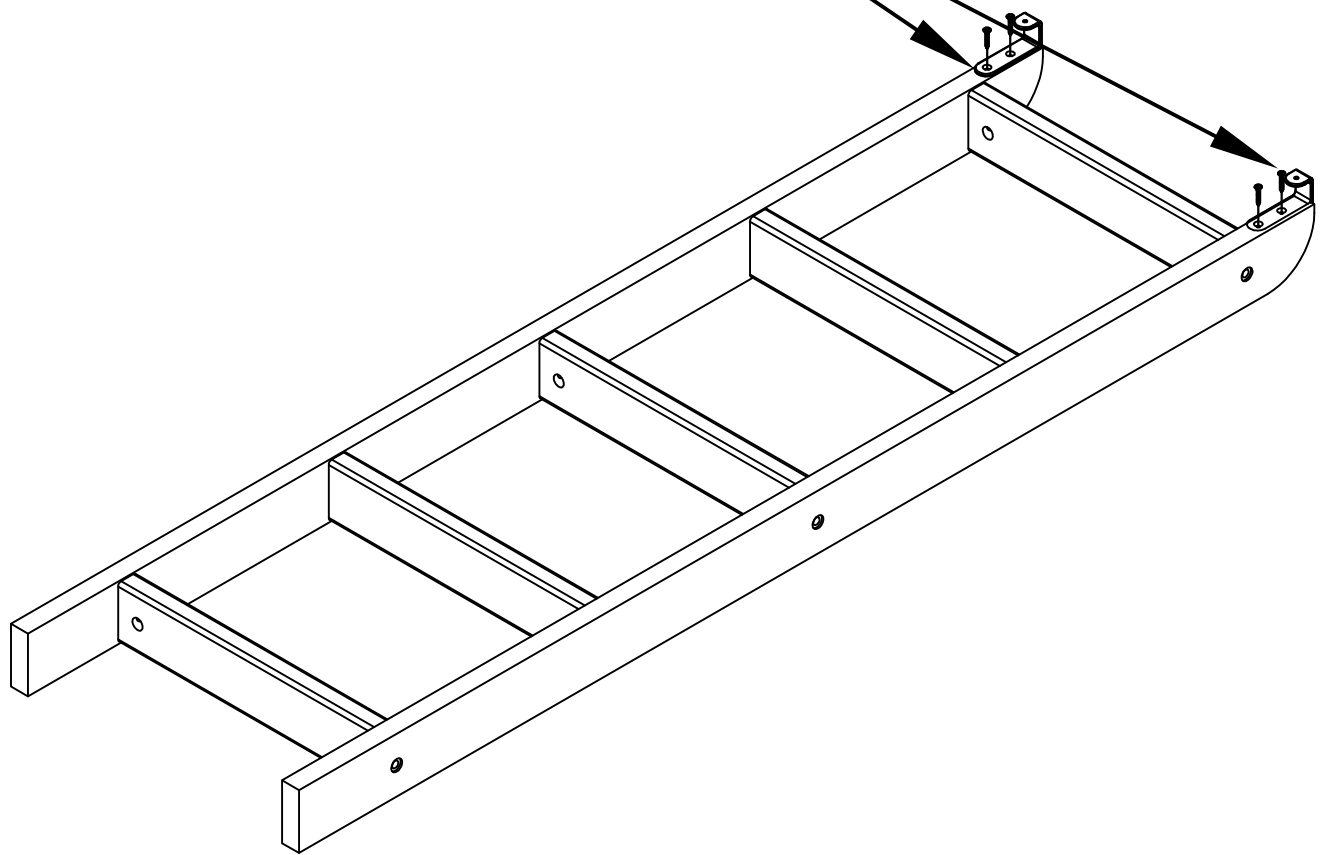

A

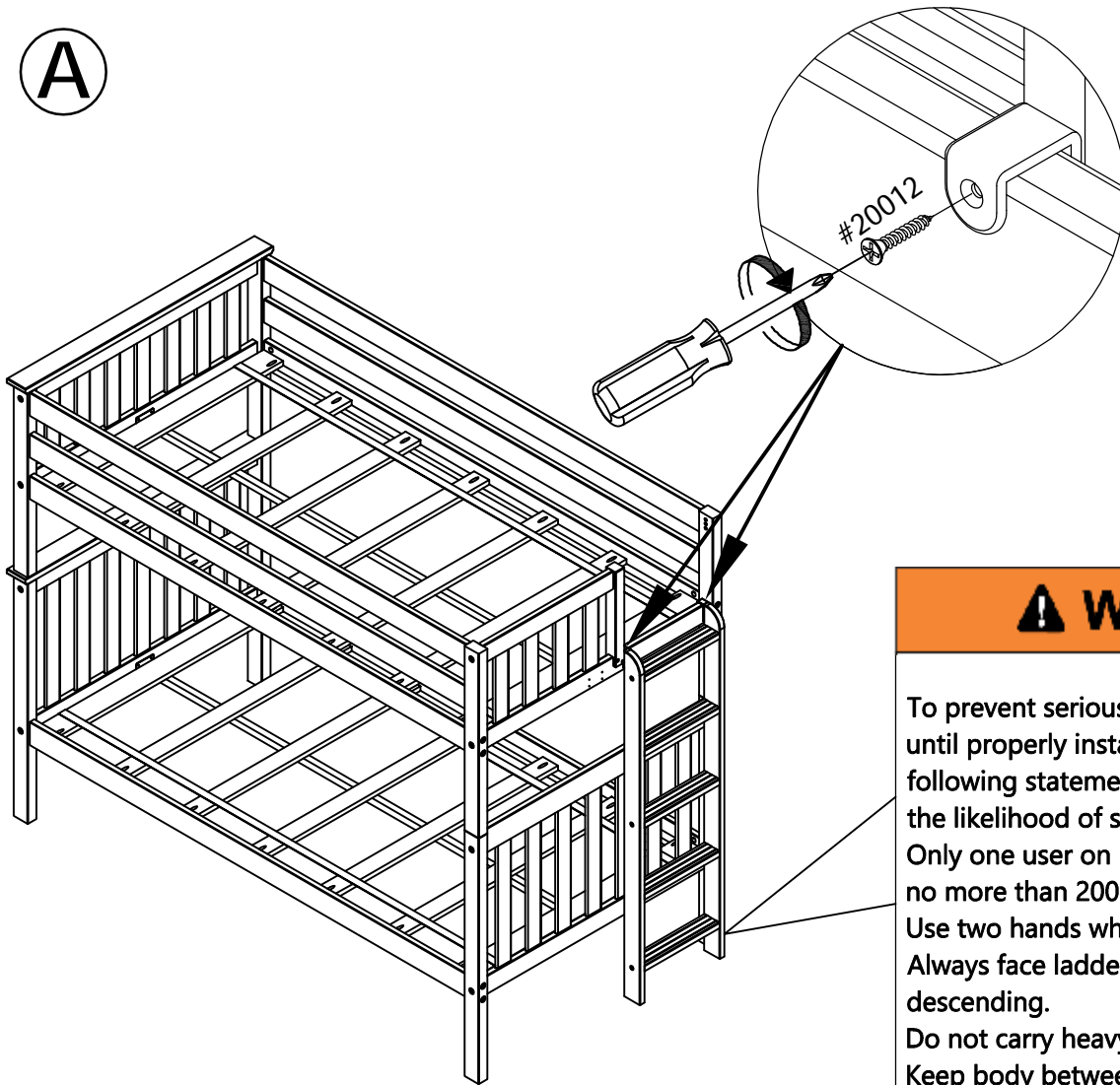

 20012 (3*19mm)
2x

⚠ WARNING

To prevent serious injury, do not use ladder until properly installed. Observing the following statements and warnings reduces the likelihood of serious or fatal injury. Only one user on ladder at a time, weighing no more than 200lbs. Use two hands when using ladder. Always face ladder when climbing or descending. Do not carry heavy load while on ladder. Keep body between sides of ladder. Do not jump off or onto ladder.

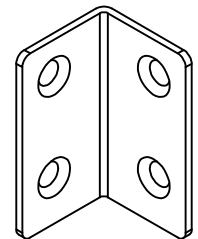
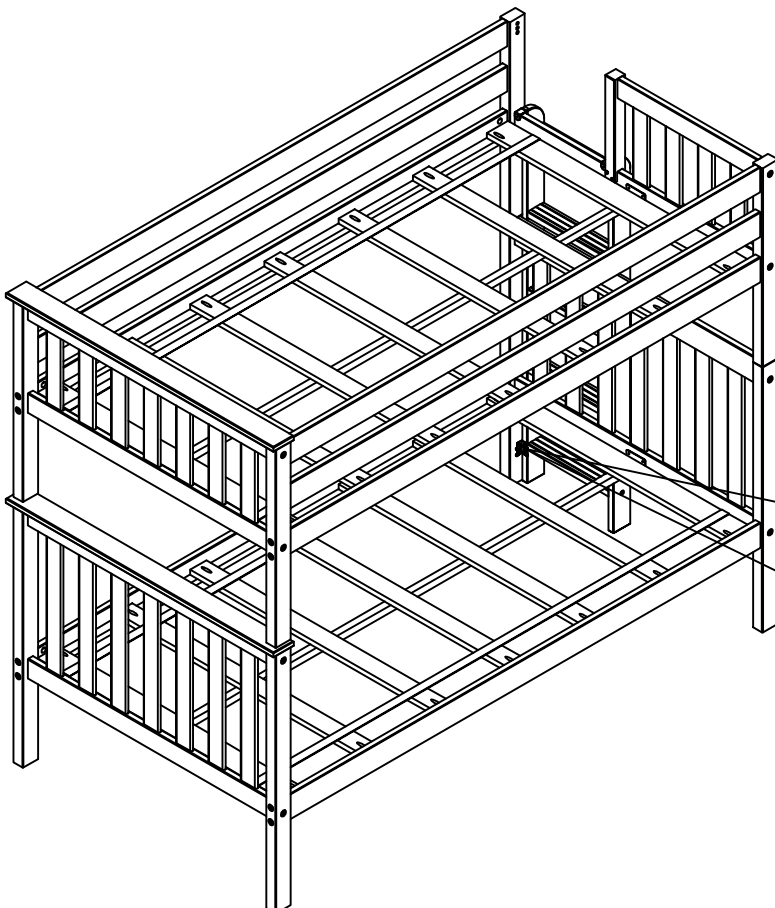

1x

20017(Pate L)

 20012 (3*19mm)
4x

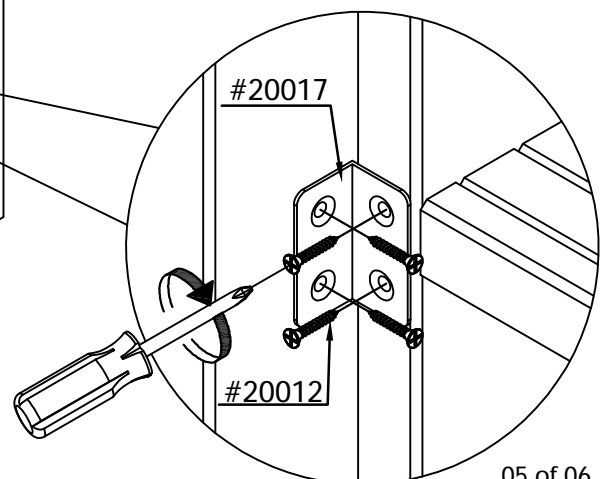

B

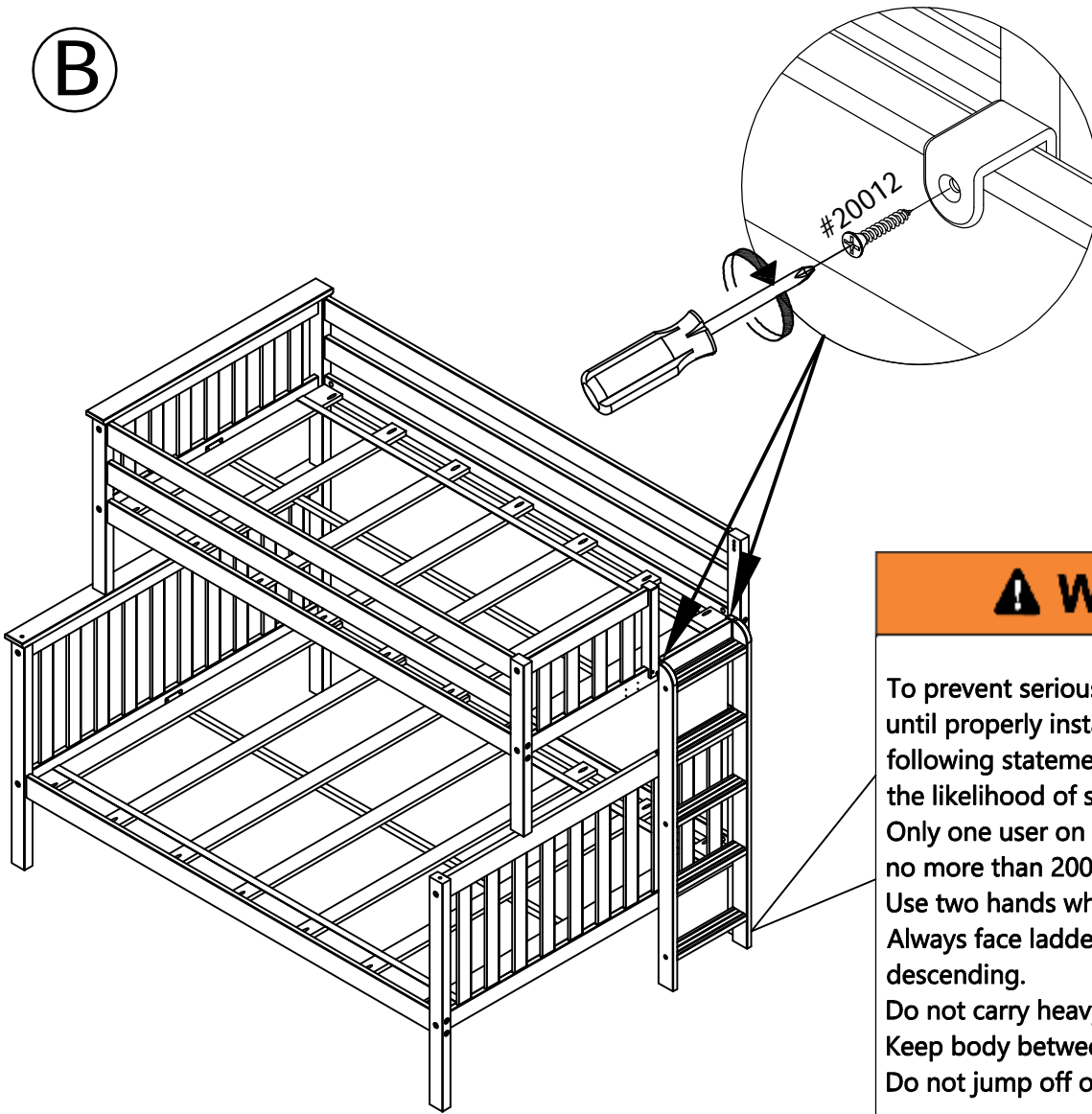

20012 (3*19mm)
2x

⚠ WARNING

To prevent serious injury, do not use ladder until properly installed. Observing the following statements and warnings reduces the likelihood of serious or fatal injury. Only one user on ladder at a time, weighing no more than 200lbs. Use two hands when using ladder. Always face ladder when climbing or descending. Do not carry heavy load while on ladder. Keep body between sides of ladder. Do not jump off or onto ladder.

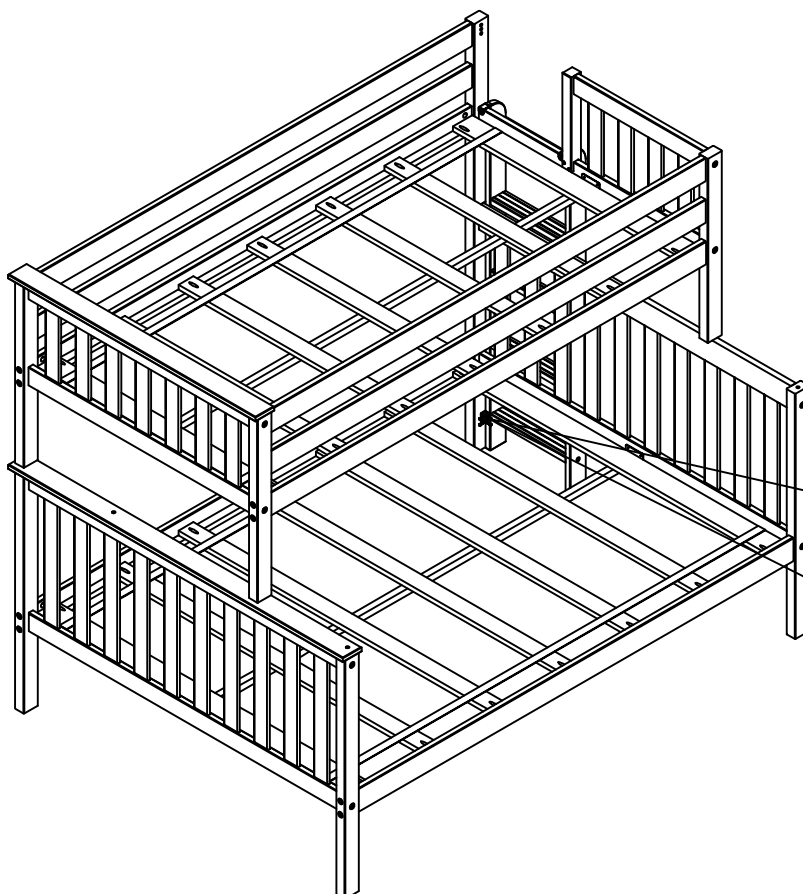

20017(Pate L) 1x
20012 (3*19mm) 4x

