

Assembly Instructions

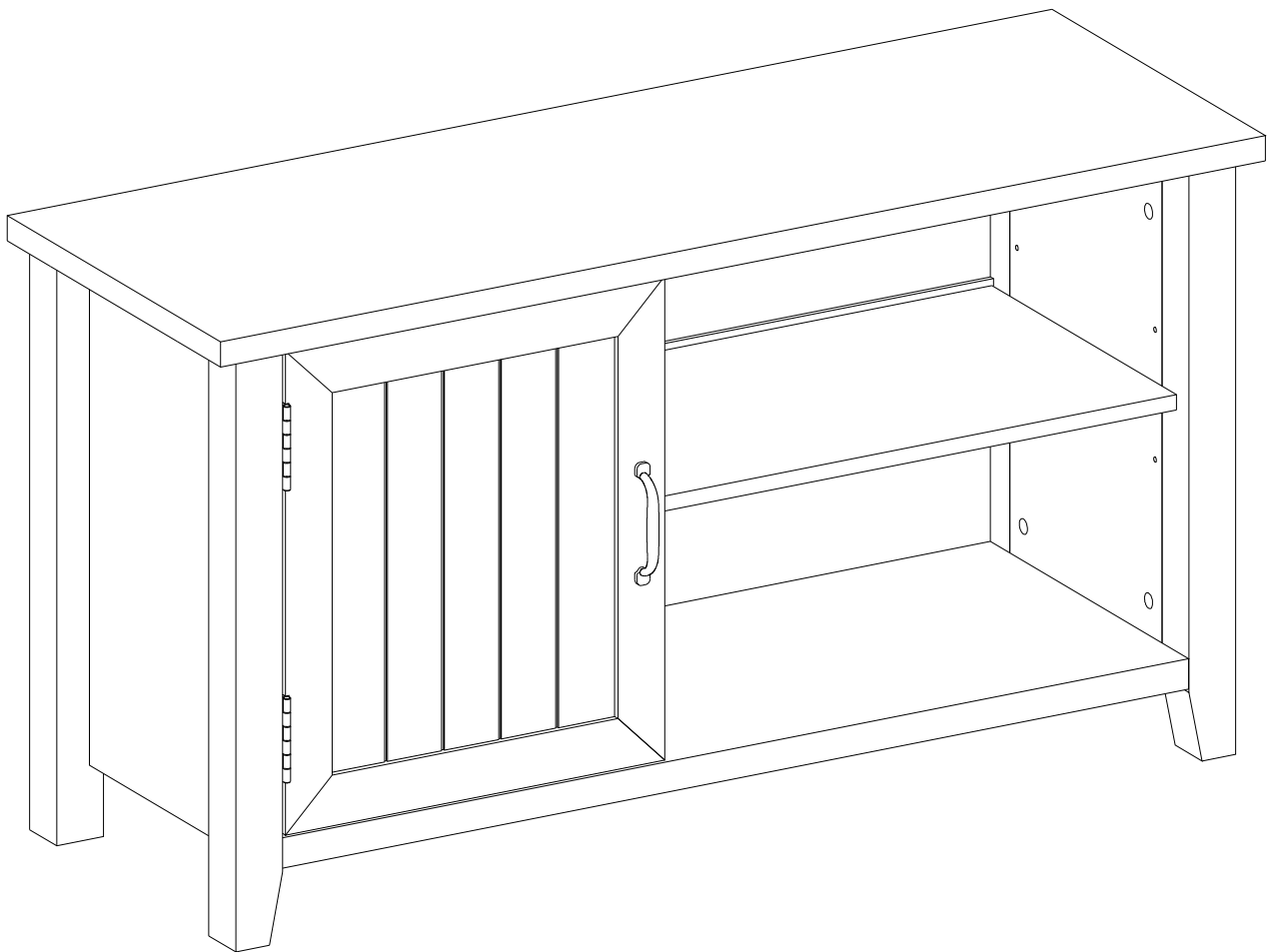

Please visit our website for the most current instructions, assembly tips, report damage, or request parts.

General Assembly Guidelines

- I. Ensure that all parts and hardware are available before beginning assembly.
- II. Follow each step carefully to ensure the proper assembly of this product.
- III. Two people are recommended for ease in the assembly of this product.
- IV. The three main types of hardware used to assemble this product are: wood dowels, screws and bolts.
- V. The provided glue is to secure wood dowels in place. When first inserting dowels, locate the appropriate hole for the dowel, place a small amount of glue in the hole and insert the dowel. Wipe away excess glue immediately.

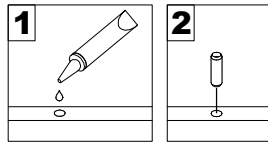

In future assembly steps when dowels are necessary to attach assembly parts together, place a small amount of glue on the end of the dowel before attaching parts together. Wipe away excess glue immediately.

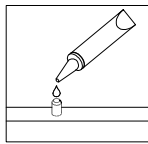

- VI. A Phillips head screwdriver is required for the assembly of this product .

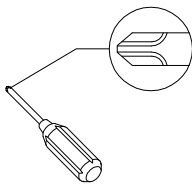

- VII. Power tools should not be used to assemble this product.

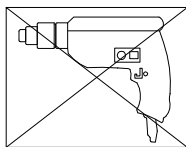





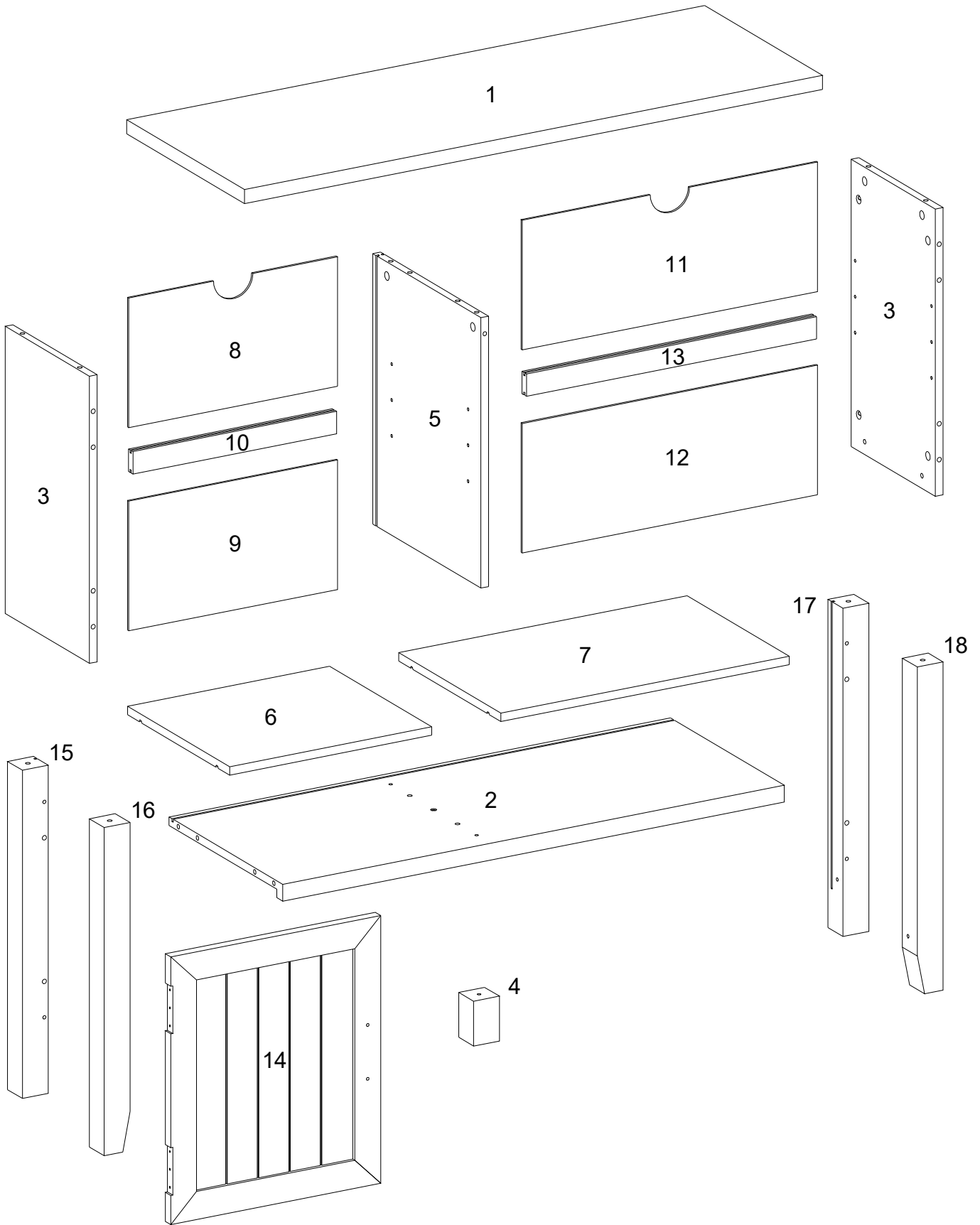



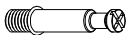

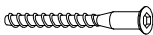







- VIII. Drill may be needed for securing product to wall.

Parts List



Hardware List

A		Ø8x30mm	Wooden dowel	20 pcs
B		Ø6x35mm	Cam bolt	18 pcs
C		Ø15x11mm	Cam lock	18 pcs
D		Ø30mm	Sticker	18 pcs
E		Ø6x50mm	Screw	3 pcs
F		M 4	Hex key	1 pc
G			Handle	1 pc
H		Ø4x25mm	Handle Bolt	2 pcs
J			Shelf support pin	8 pcs
K		Ø13x5x10mm	Bolt	1 pc
L			Hinge	2 pcs
M		Ø4x20mm	Screw	12 pcs
N		Ø4x15mm	Screw	4 pcs
P		Ø3x17mm	Screw	12 pcs
Q			Plastic wedge	12 pcs
R			Glue tube	1 pc
S		Ø4x12mm	Screw	1 pc
T		Ø4x25mm	Screw	1 pc
U			Plastic strap	1 pc
V			Nut	1 pc

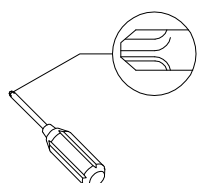

Philips head screwdriver required for assembly
(not included)

*The hardware quantities listed above are required for proper assembly.
Some extra hardware may also have been included.*

Step 1

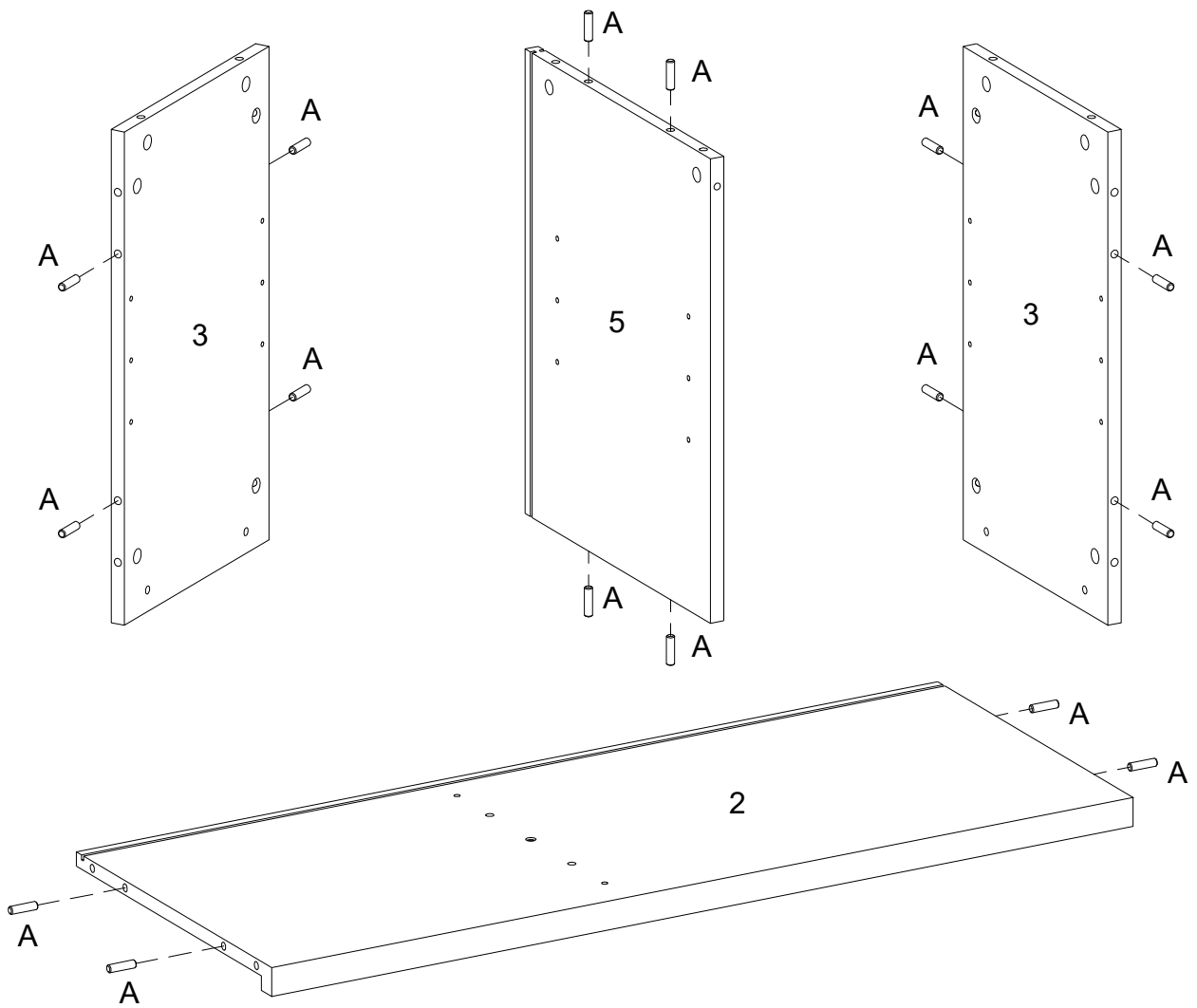

Insert wooden dowel (A) into parts (2,3,5) as per diagram.

Step 2

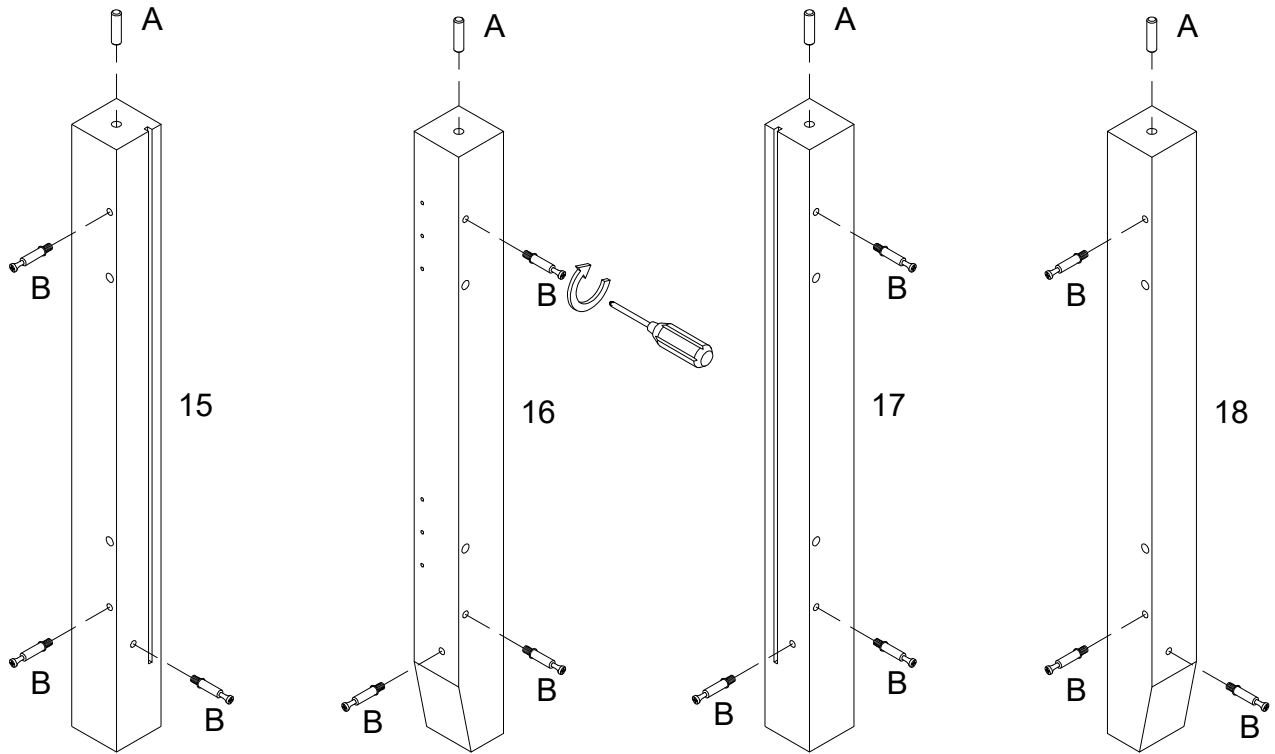

Insert wooden dowel (A) into parts (15,16,17,18) , then secure cam bolt (B) into parts (15,16,17,18) with Philips head screwdriver as per diagram.

Step 3

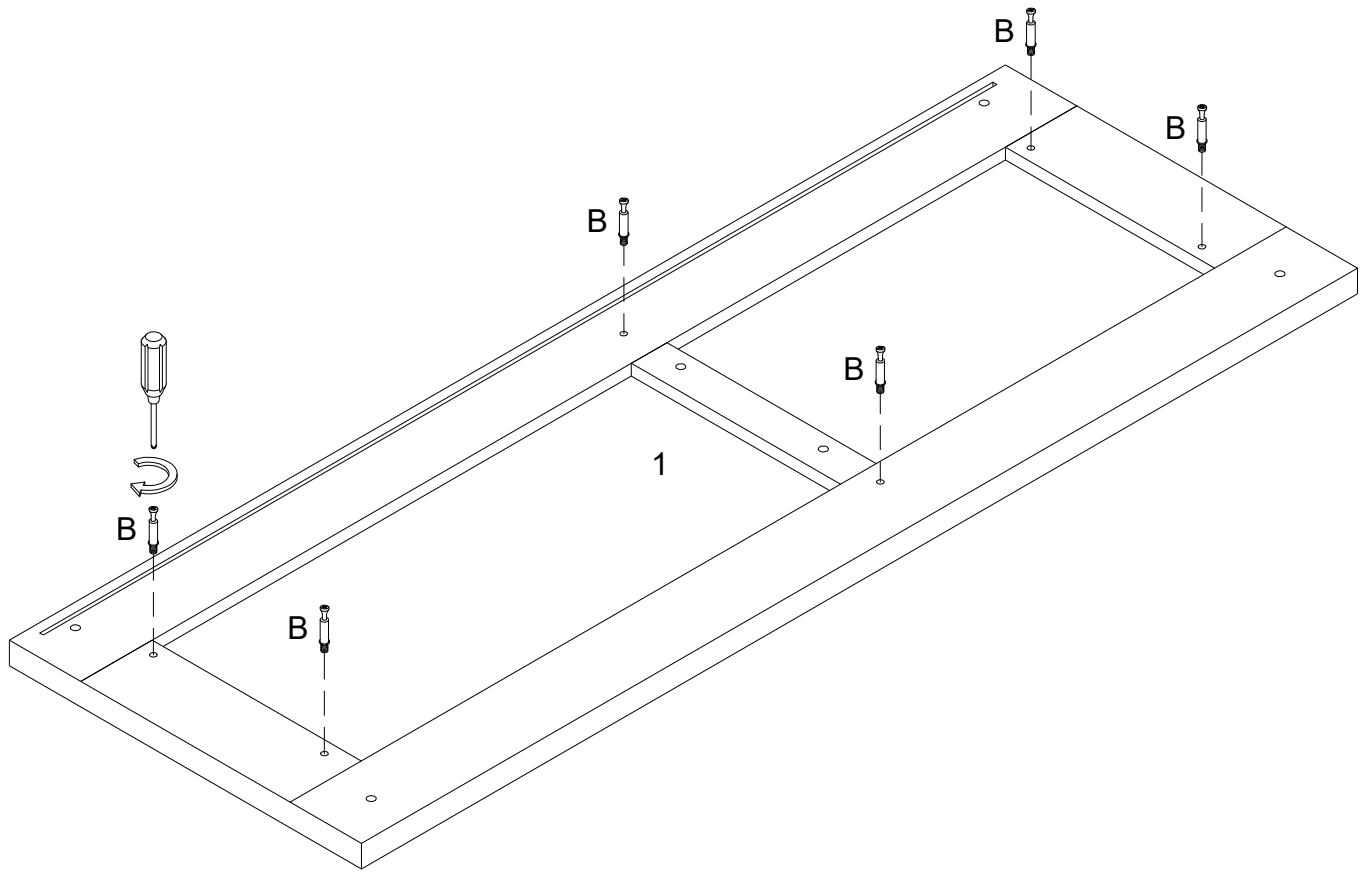

Secure cam bolt (B) into part (1) with Philips head screwdriver as per diagram.

Step 4

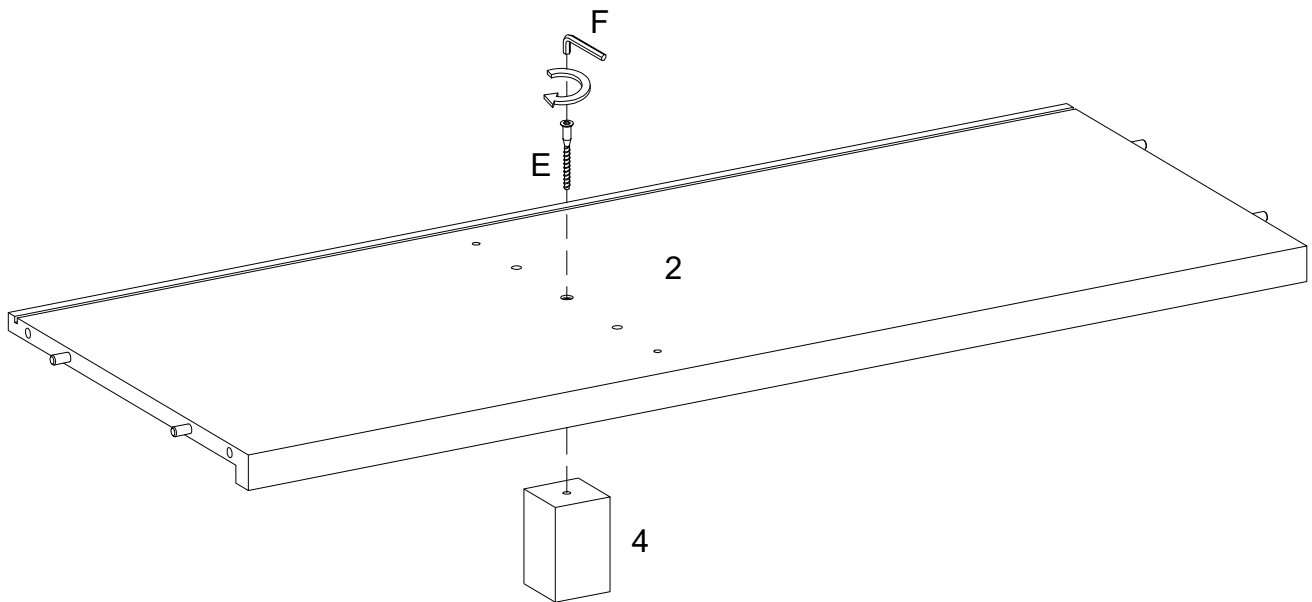

Using screw (E) attach part (4) to part (2) with Hex key (F) as per diagram.

Step 5

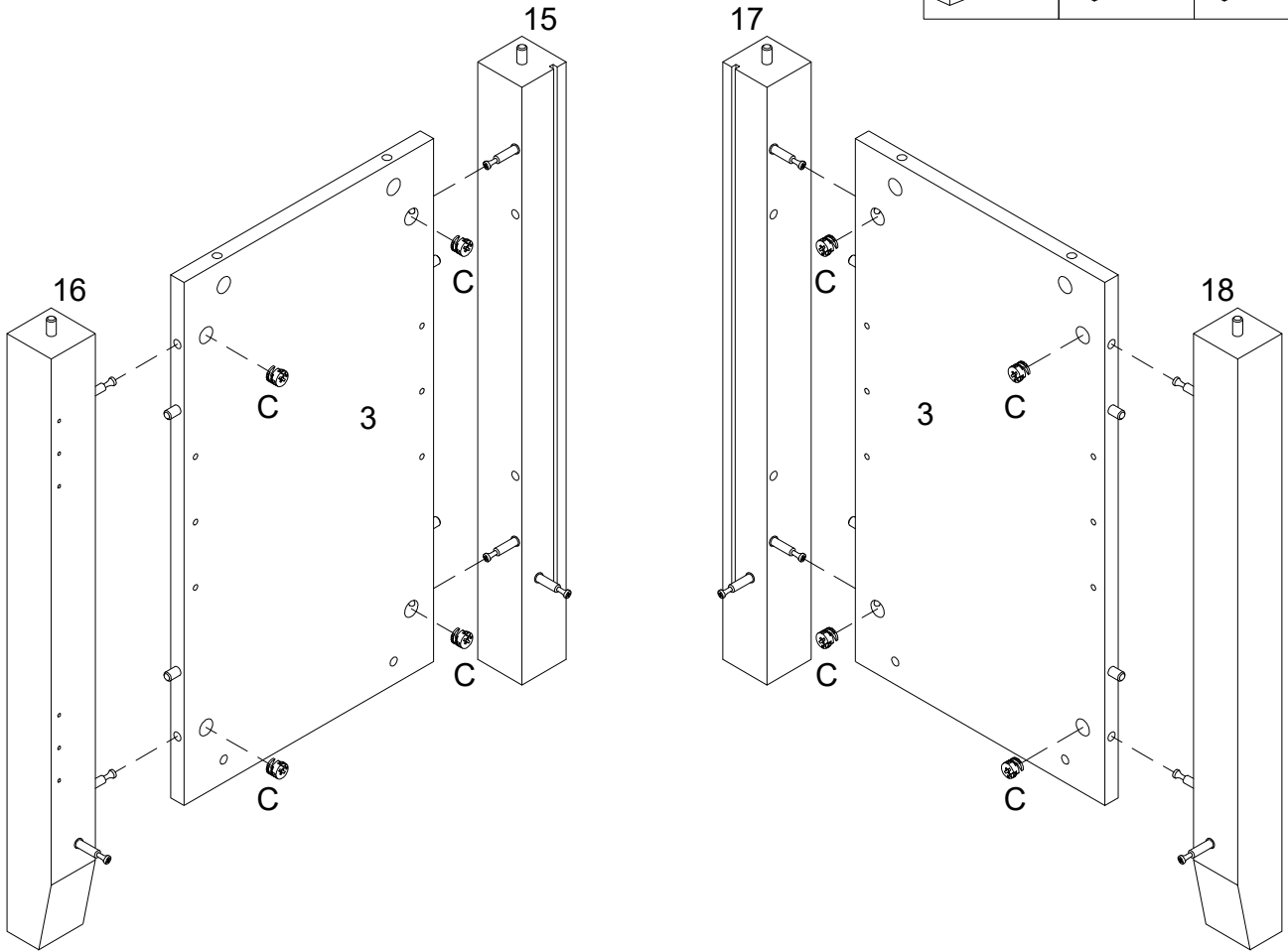
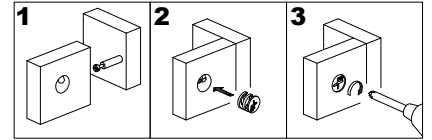

Using Cam lock(C) secure parts (15,16,17,18) to part (3) with Philips head screwdriver as per diagram.

Step 6

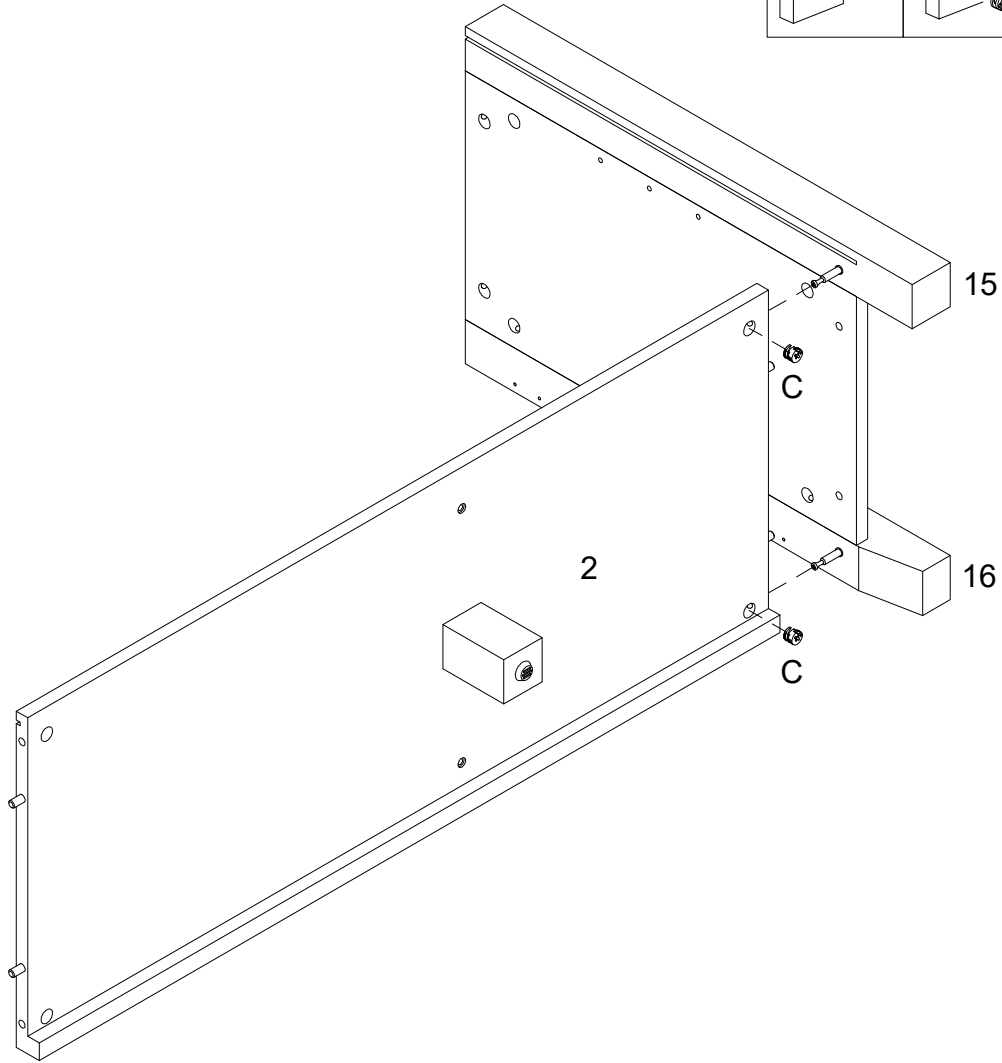
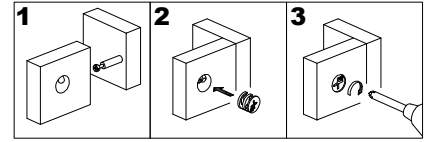

Using Cam lock(C) secure part (2) to parts (15,16) with Philips head screwdriver as per diagram.

Step 7

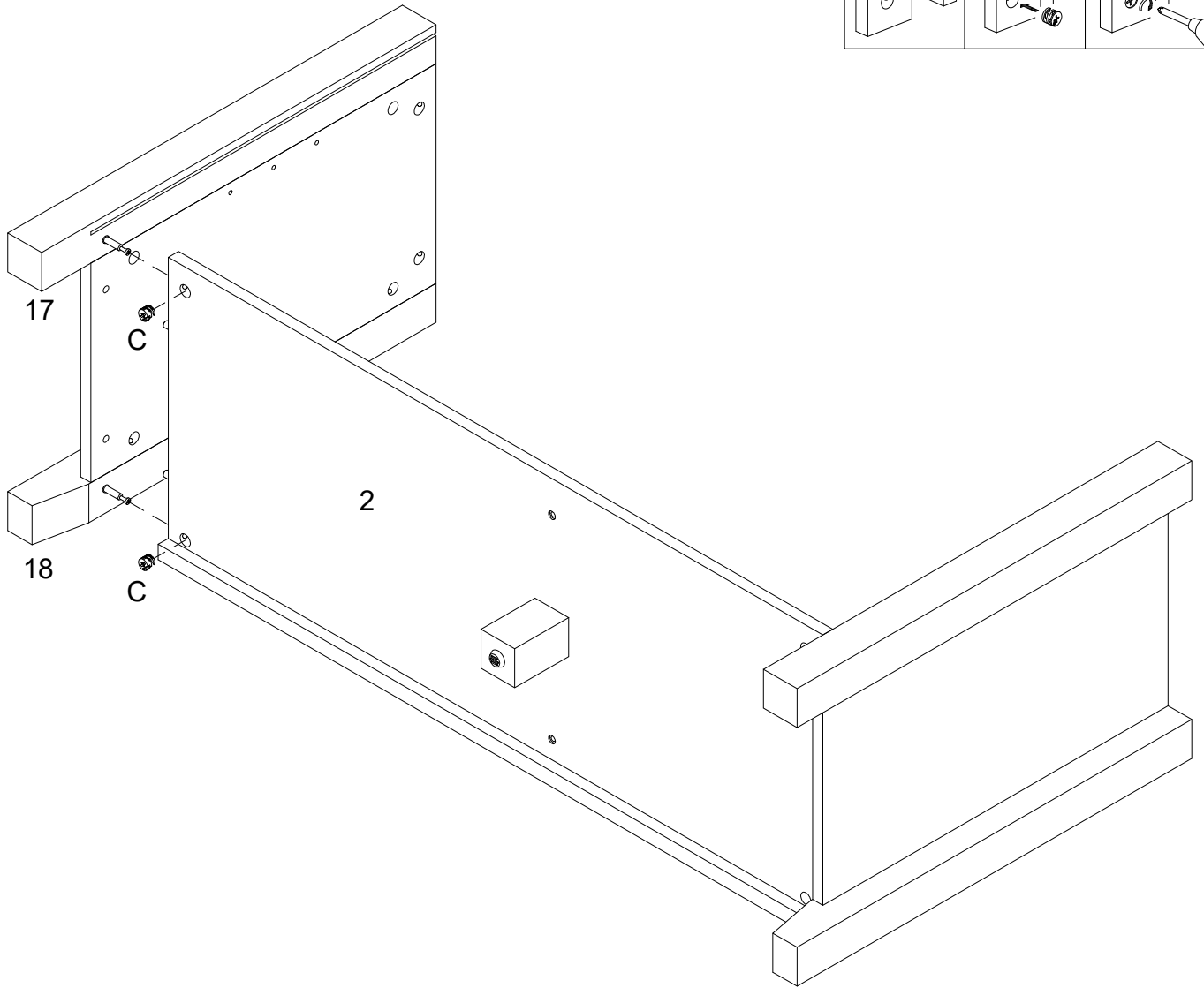
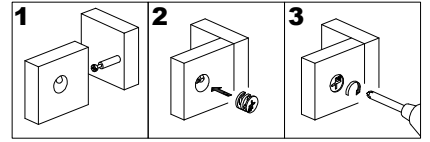

Using Cam lock(C) secure part (2) to parts (17,18) with Philips head screwdriver as per diagram.

Step 8

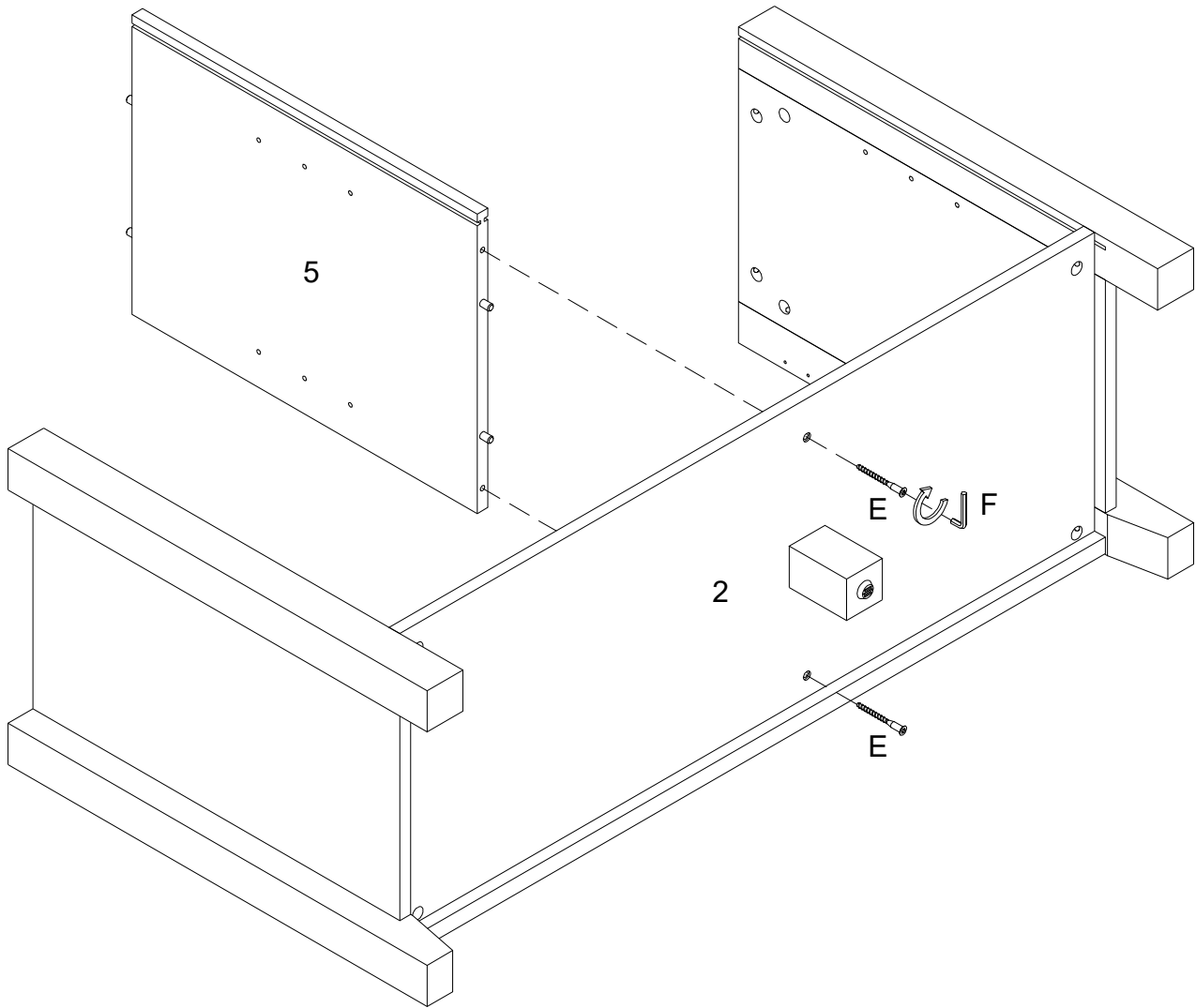

Attach part (5) into part (2) ,then using screw (E) attach part (5) into part (2) with Hex key (F) as per diagram.

Step 9

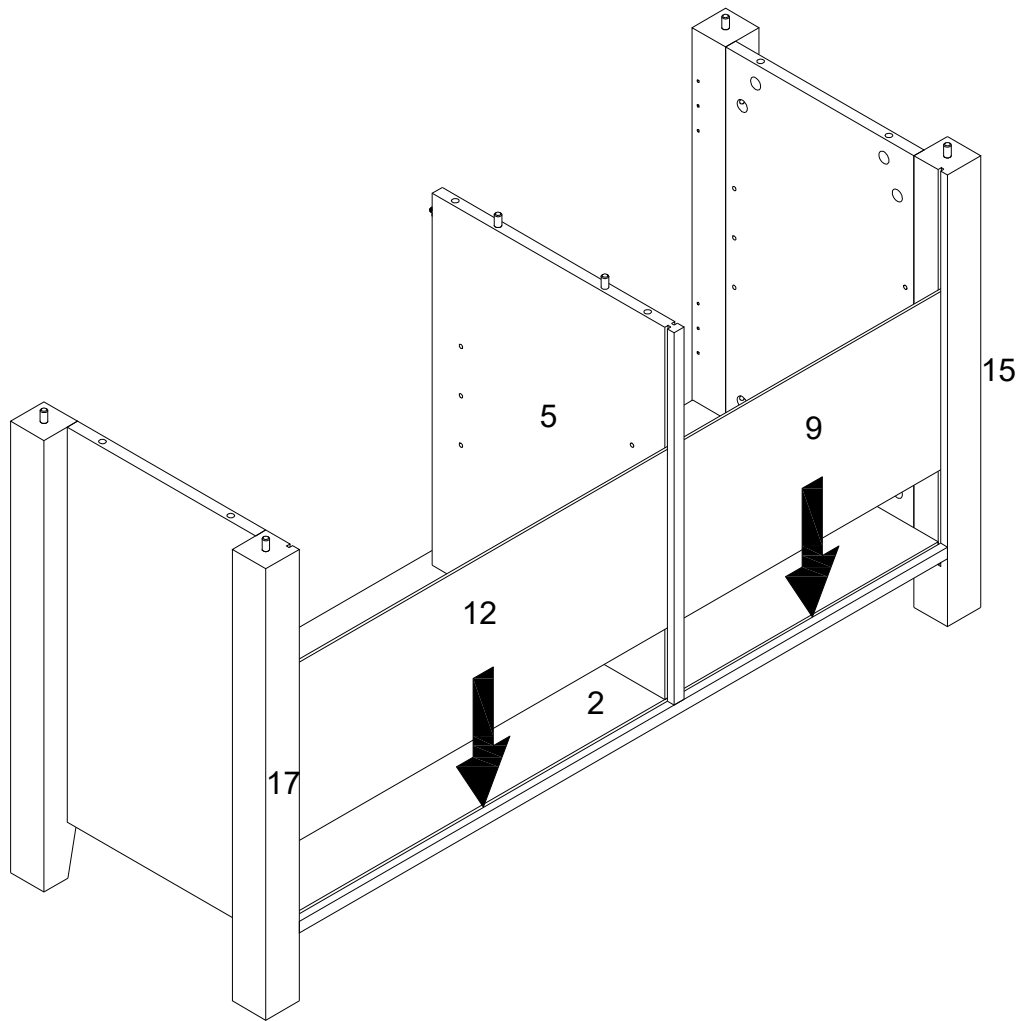

Put parts (9,12) as per diagram.

Step 10

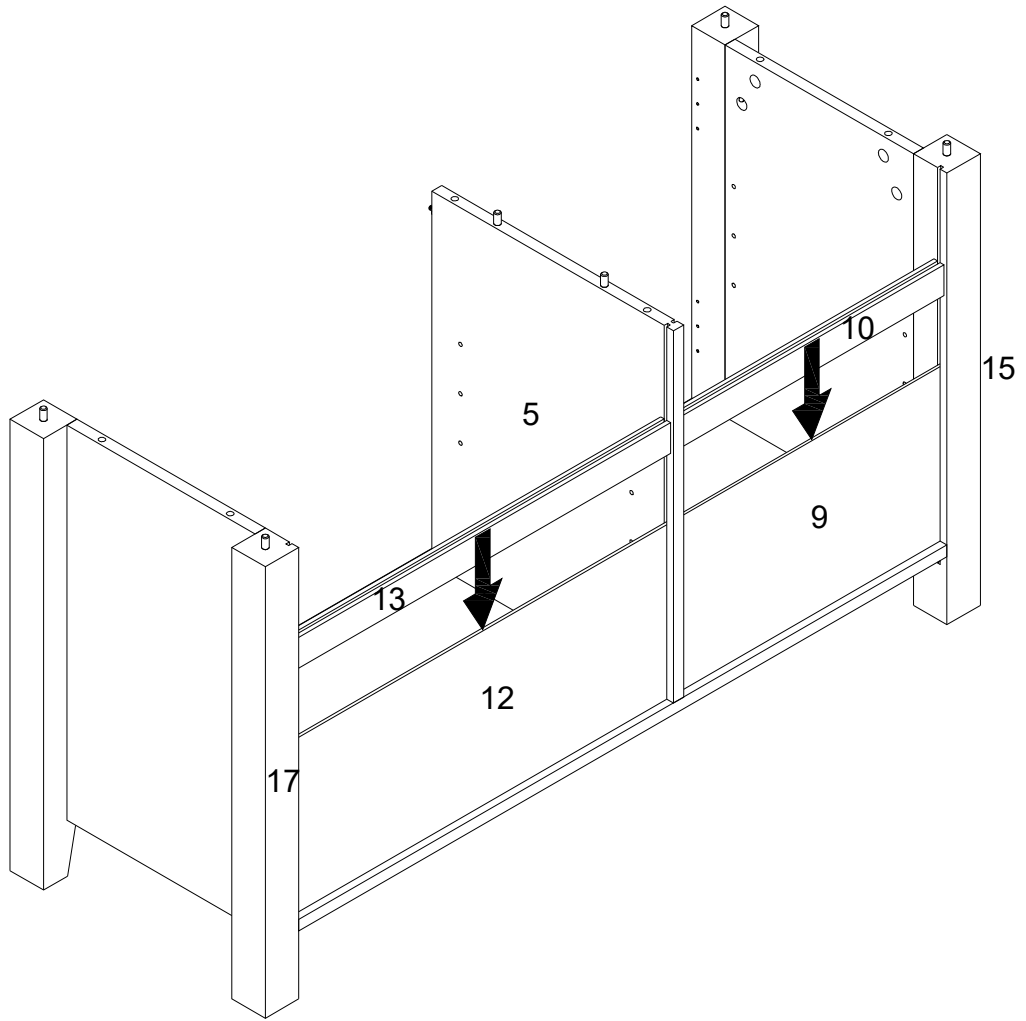

Put parts (10,13) as per diagram.

Step 11

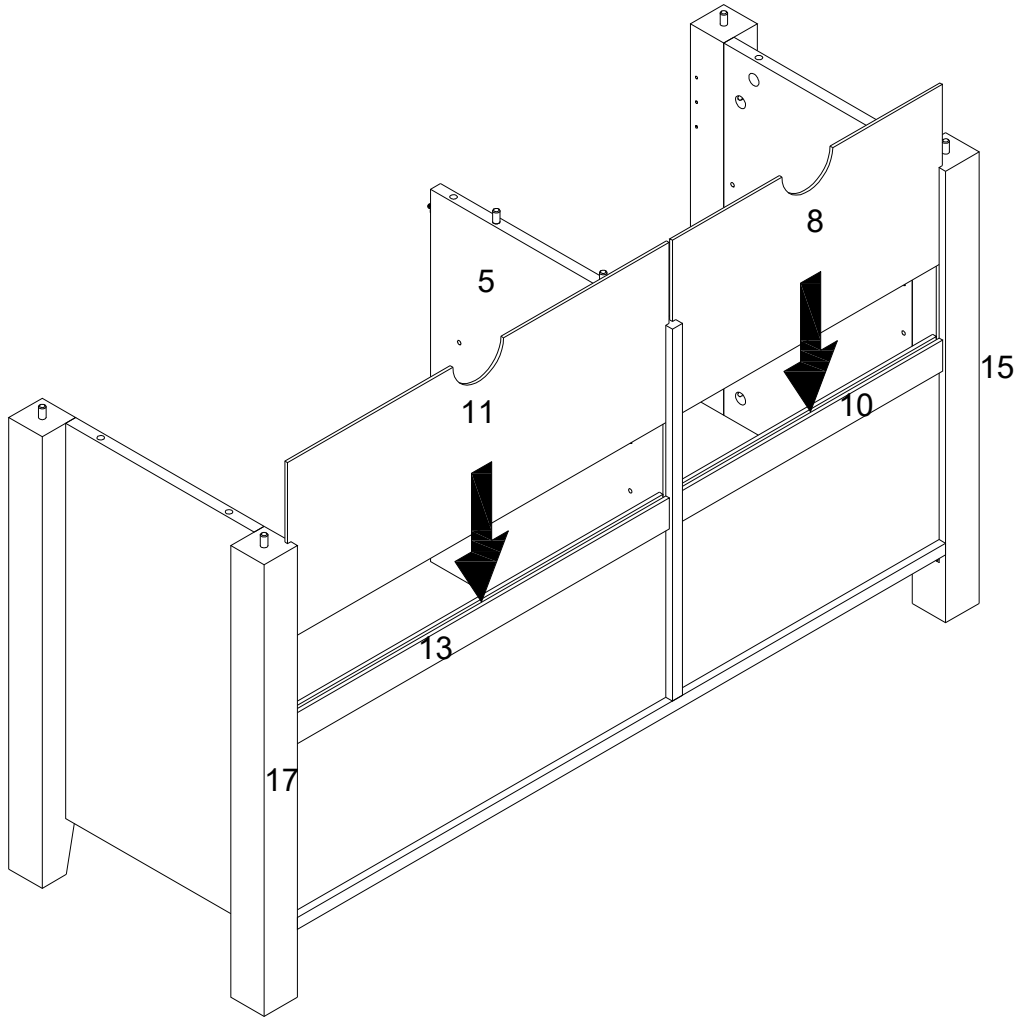

Put parts (8,11) as per diagram.

Step 12

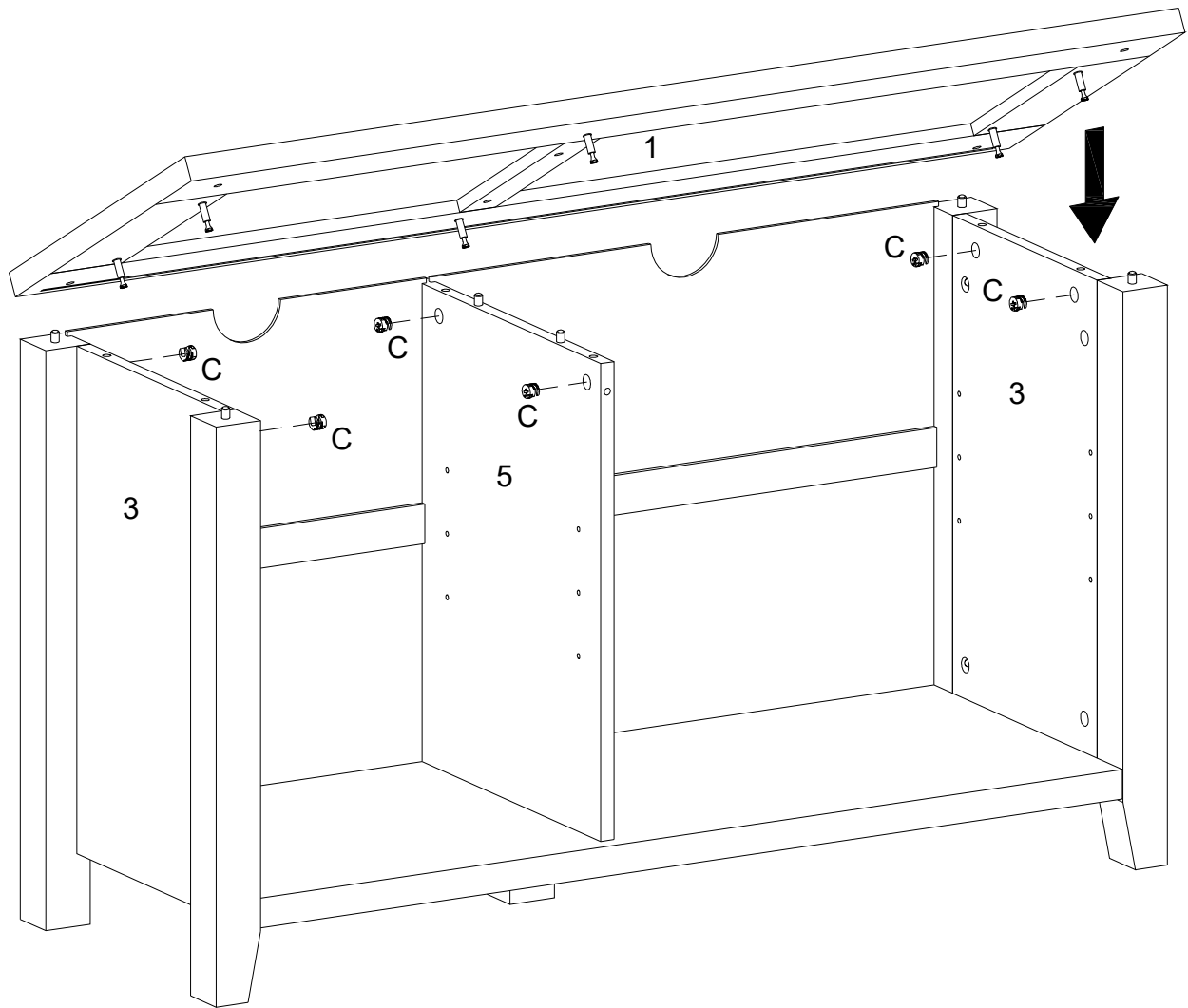
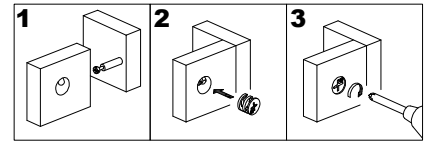

Using cam lock (C) secure part (1) to parts (3,5) with Philips head screwdriver as per diagram.

Step 13

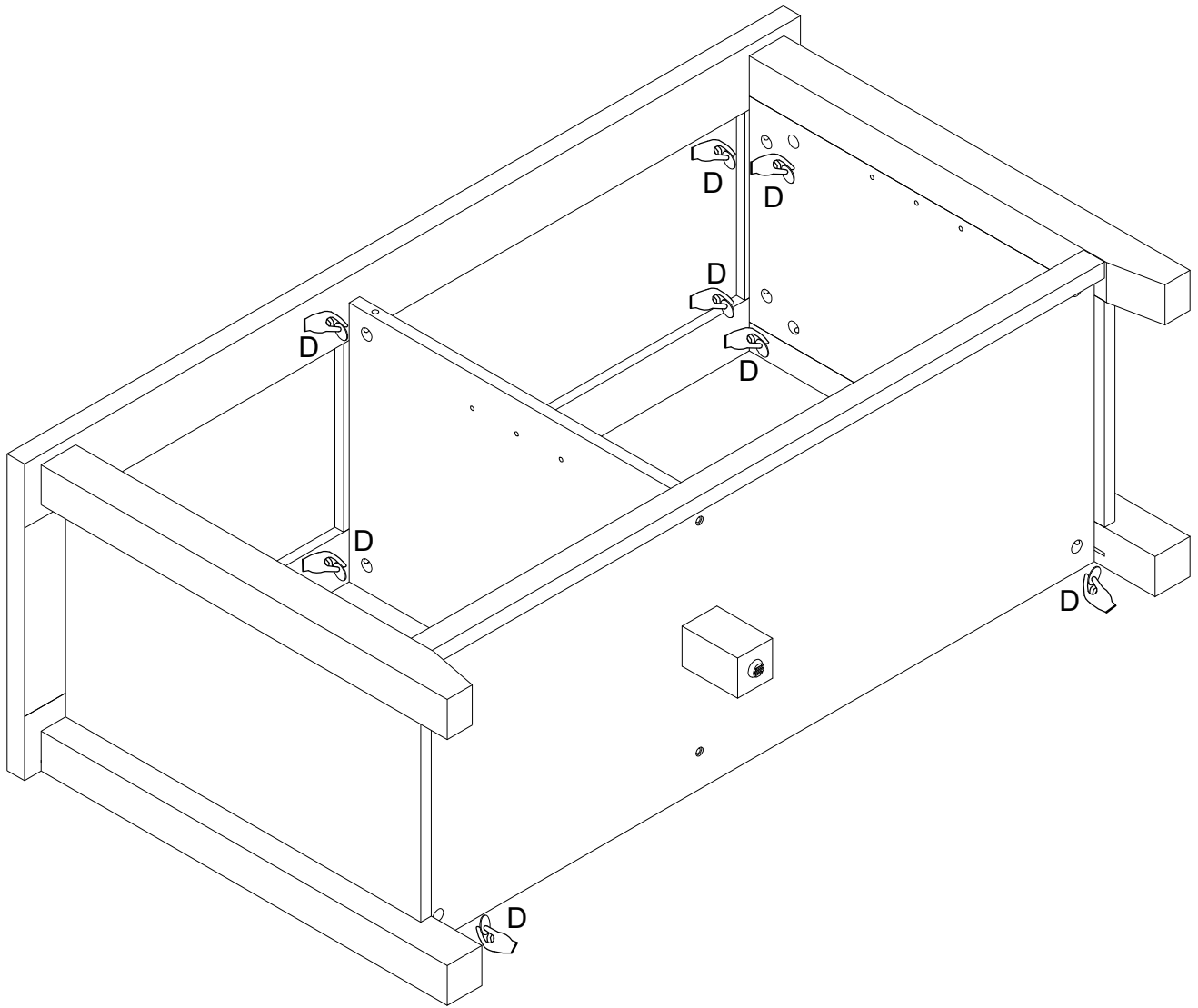

Place sticker (D) cover the holes as per diagram .

Step 14

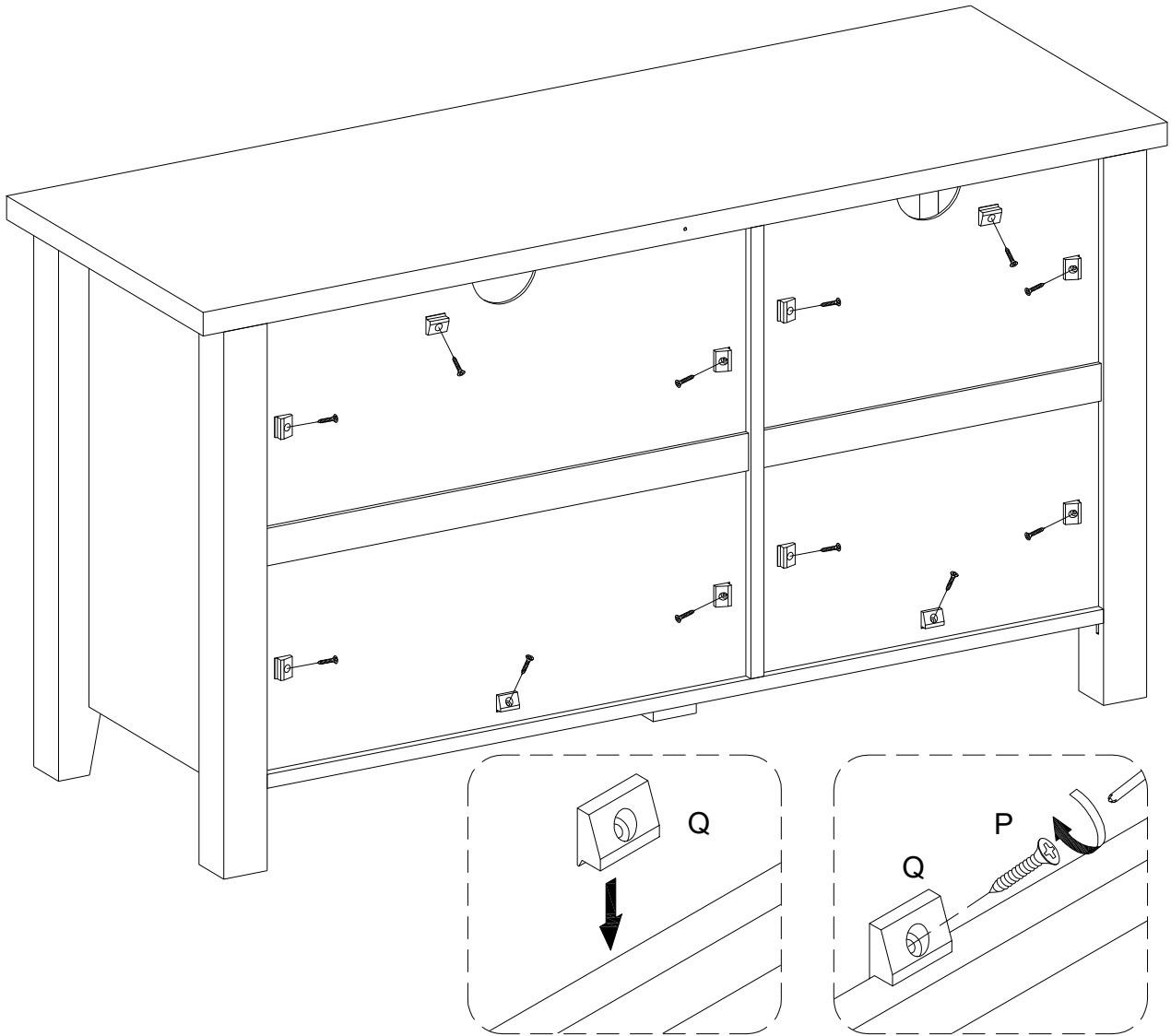

Using screw (P) secure plastic wedge (Q) with Philips head screwdriver as per diagram.

Step 15

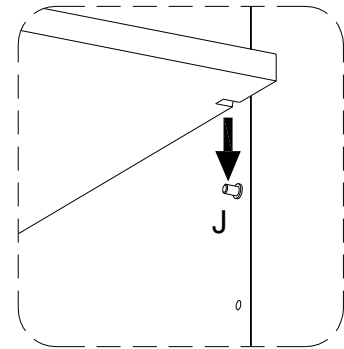
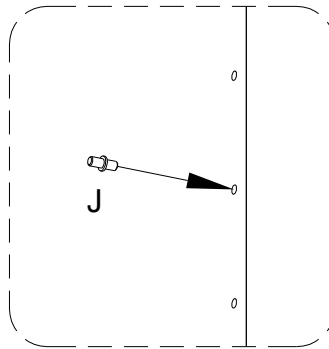
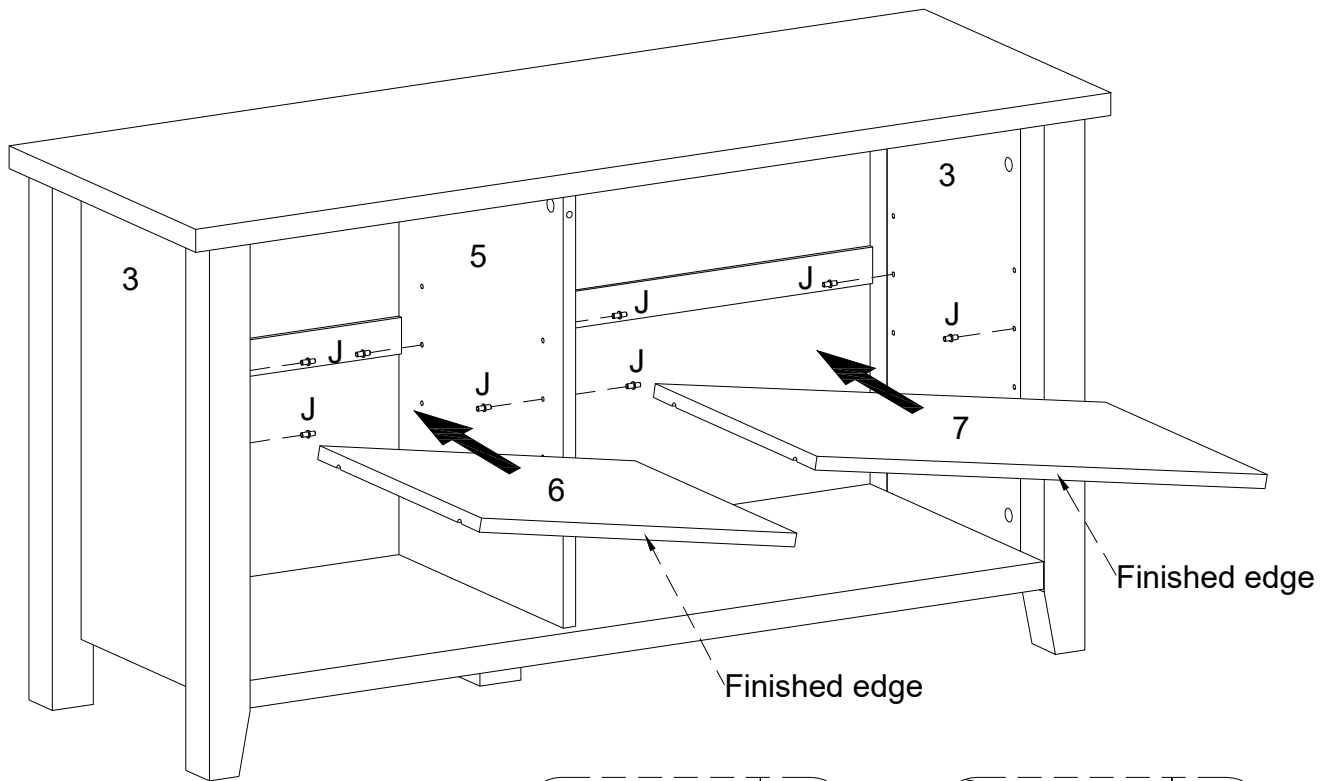

Insert shelf support pin (J) into parts (3,5) as per diagram. Make sure you place shelf support pins (J) in the same level. So the shelf is not titled .Put parts (6,7) into unit as per diagram. Tilt and rest the adjustable shelf (6,7) onto the shelf support pins .

Step 16

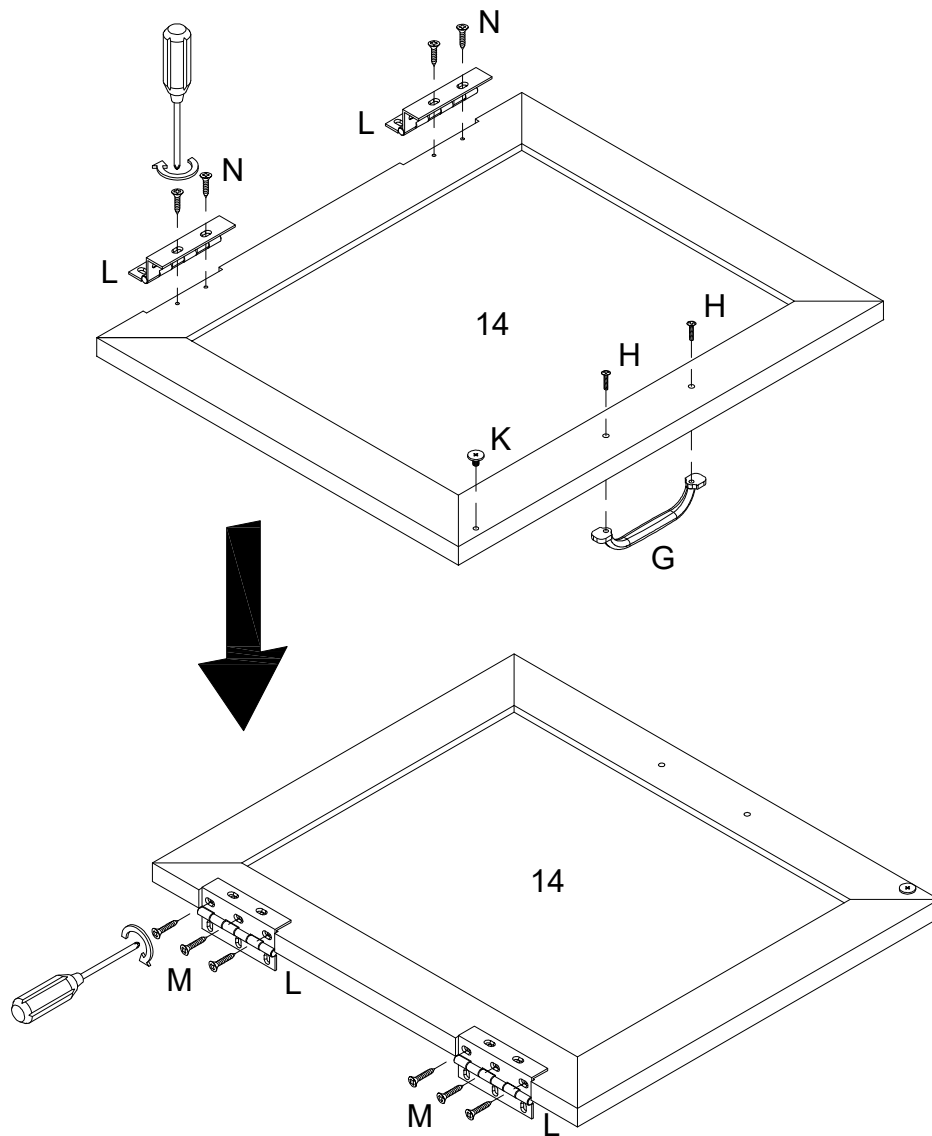

Using screw (N,M) attach Hinge (L) to part (14) with Philips head screwdriver as per diagram. Then secure bolt (K) into part (14), and use handle bolt (H) attach handle (G) to part (14) with with Philips head screwdriver as per diagram.

Step 17

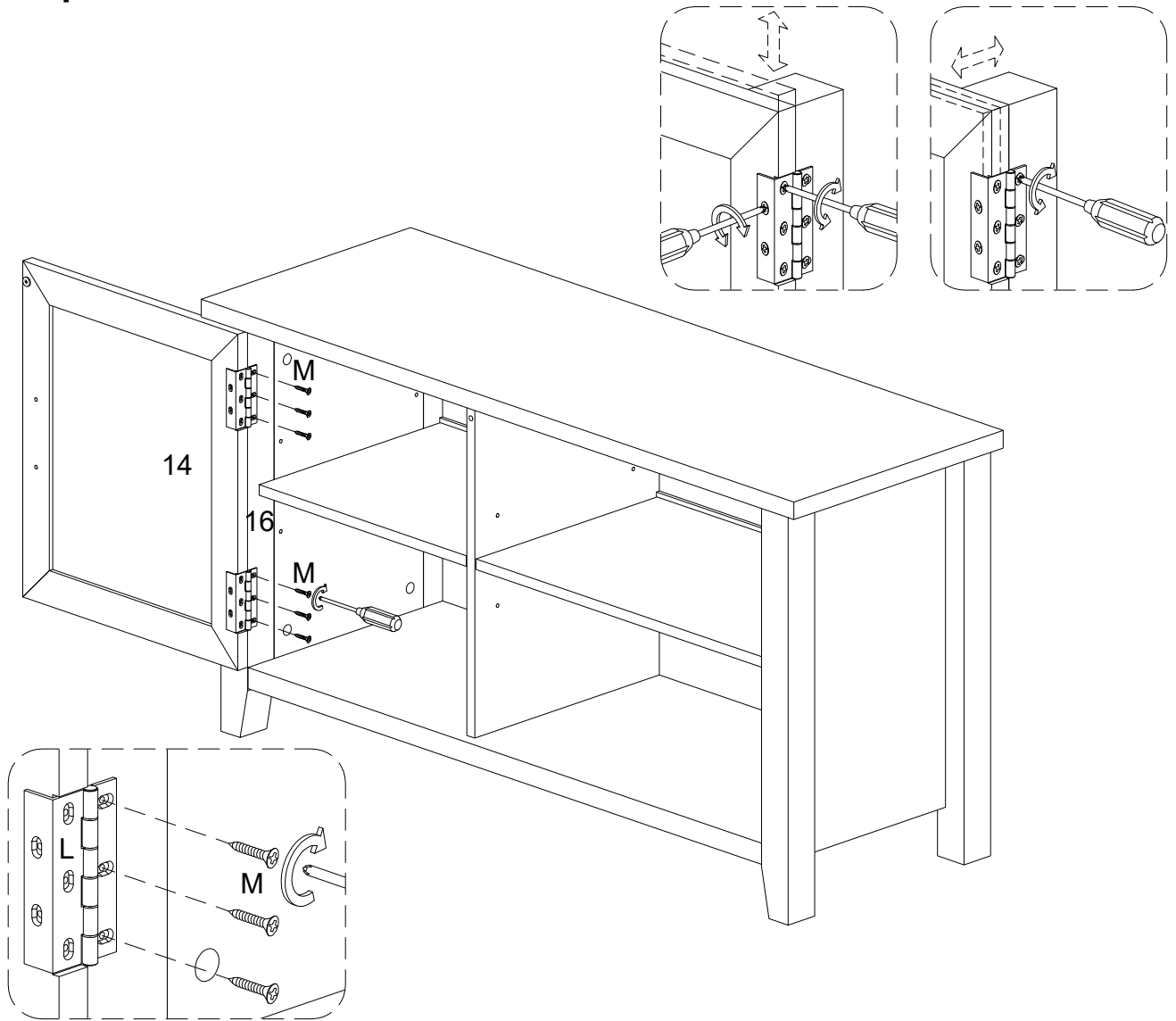

Using screw (M) attach Hinge(L) to part (16) with Philips head screwdriver as per diagram.

Step 18

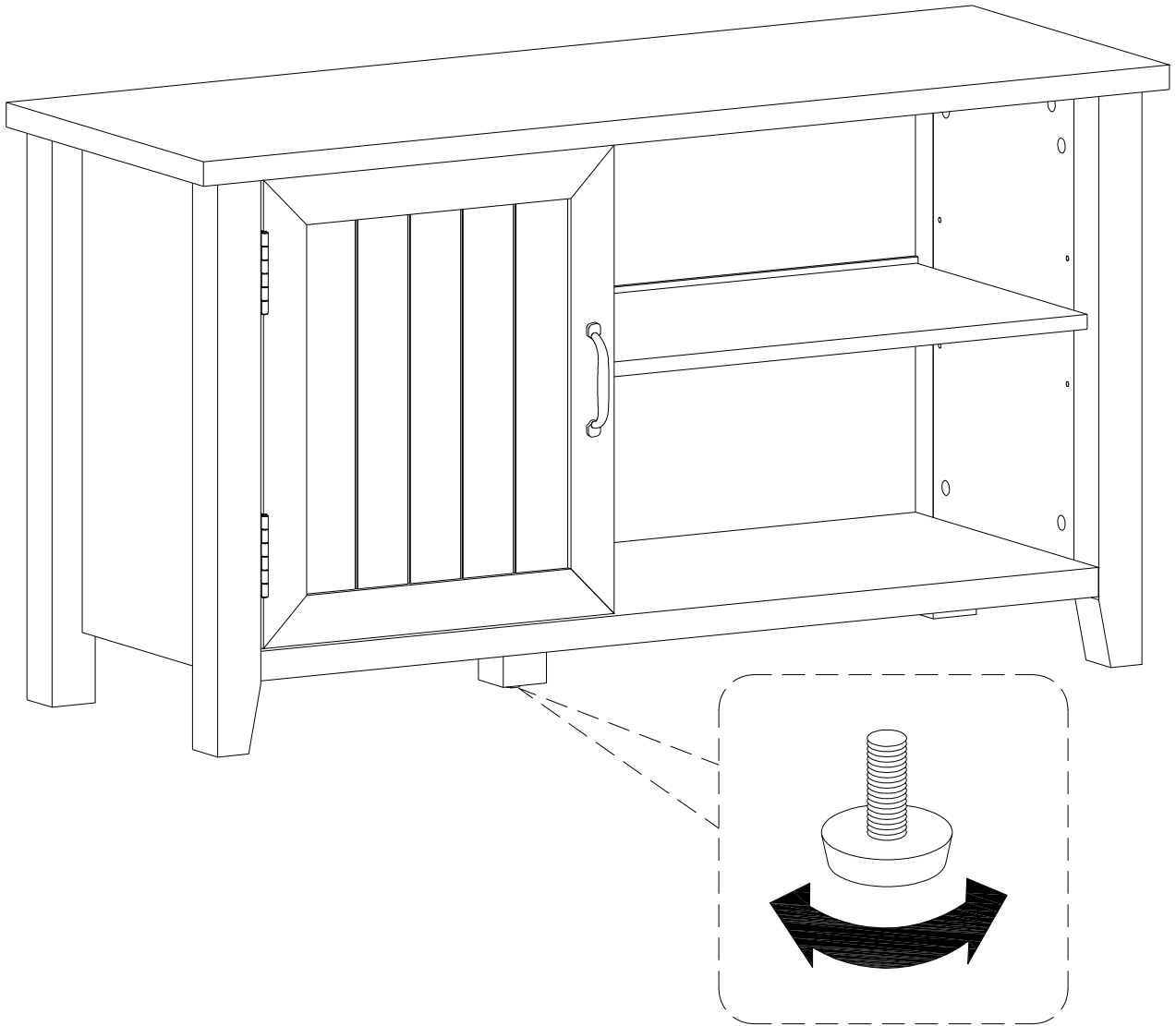

Position the assembled unit at the desired location ,if necessary adjust the floor leveler at the bottom of the support leg to level the unit .

Step 19

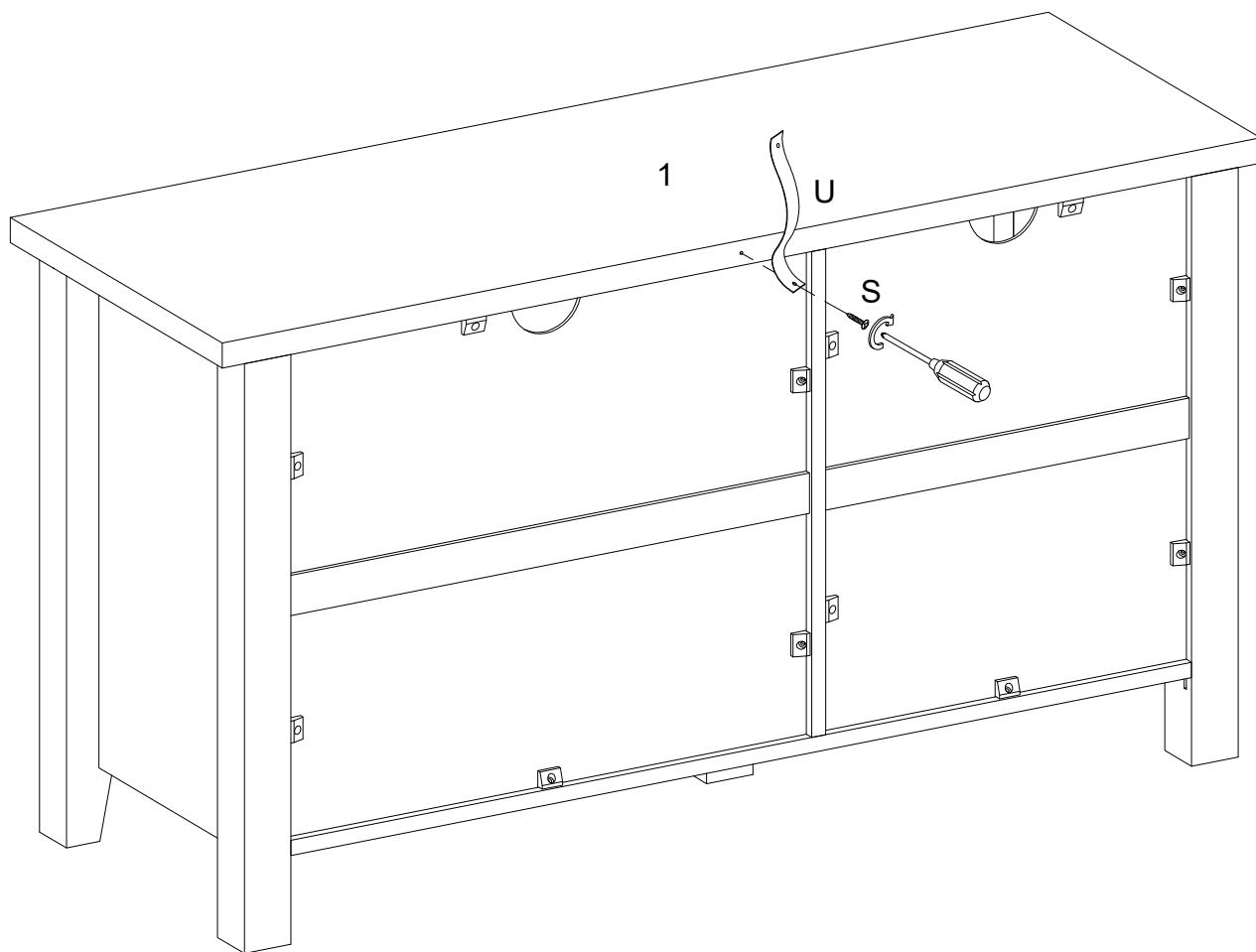

Using screw (S) attach plastic strap (U) into part (1) with Philips head screwdriver as per diagram.

Step 20

WARNING

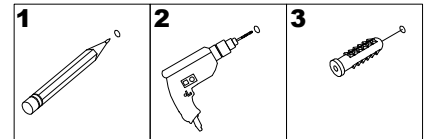

Serious or fatal injuries can occur from furniture tipping over. To prevent the furniture from tipping over we recommend that it is permanently fixed to the wall. Wall anchor and hardware are included with this product. Please make sure hardware is suitable for your walls before installing, as different wall materials may require different types of anchors.

Wall

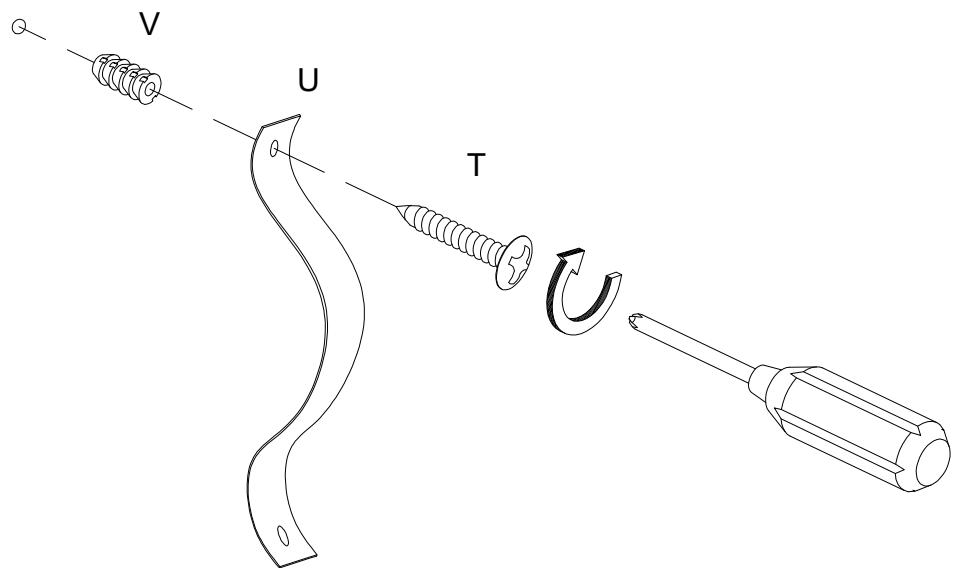

Using screw (T) attach plastic strap (U) into Nut (V) to wall with Philips head screwdriver as per diagram.

Step 21



Final Assembly