











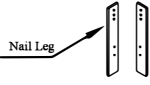

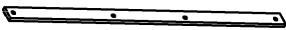
ASSEMBLY INSTRUCTION

Thank you for purchasing the quality product. Be sure to check all packing material carefully for small parts which may have come loose inside the carton during shipment. Separate, identify and count all parts and metal hardware. Compare with all parts list to be sure all parts are present. If any part(s) are missing or damaged, please contact your local furniture dealer. For efficient and speedy service, please indicate the model number and code letter of parts(s) needed.

Do not fully tighten screws until fully assembled

COMPONENT PARTS		
DESCRIPTION	PART NAME	Q'TY (PCS)
①	HEADBOARD 	1
②	FOOTBOARD 	1
③	HEADBOARD LEG(L&R) 	2
④	SIDE RAIL 	2
⑤	BED SLAT 	4
⑥	SHORT SUPPORT LEG FOR DRAWERS 	8
⑦	HEADBOARD BOTTOM STRETCHER 	1

HARDWARE REQUIRED (BOX OF HEADBOARD)

- (A)  BOLT 5/16" x 1-1/2" - 8 PCS
- (B)  SPRING WASHER 5/16" - 8 PCS
- (C)  FLAT WASHER 5/16" - 8 PCS
- (D)  ALLEN KEY M4 - 1 PC
- (F)  FLATHEAD CHIPBOARD SCREW ϕ 8" x 1" - 8 PCS

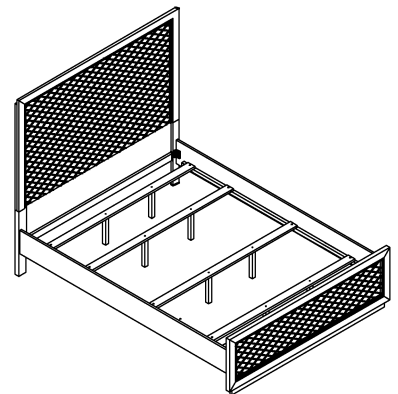

Attention:

*** Some number parts listed in the instruction sheet may not be in parts bags as they already be assembled. Carefully check parts and packing materials prior to ordering replacements.

How to assemble:

Step 1:

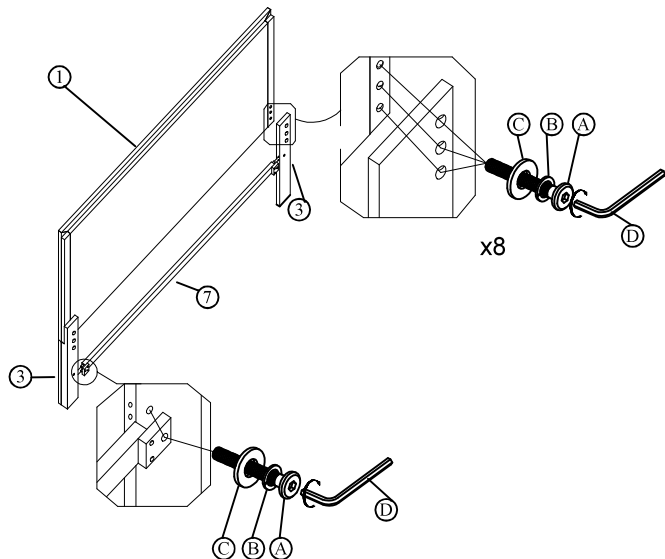

Step 2:

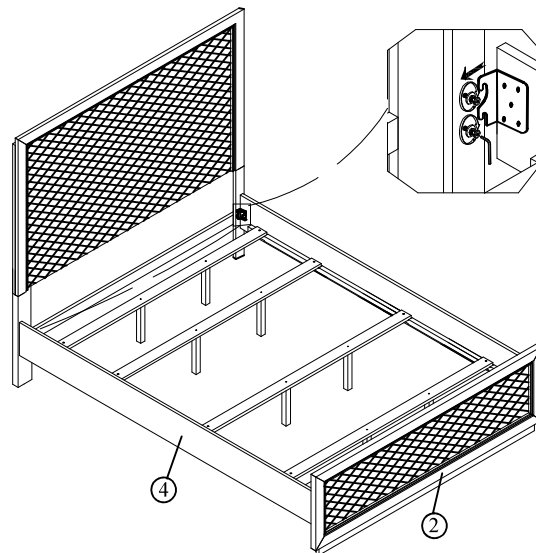

Step 3:
COMPLETE

STEP 3.1 :

STEP 3.2 :

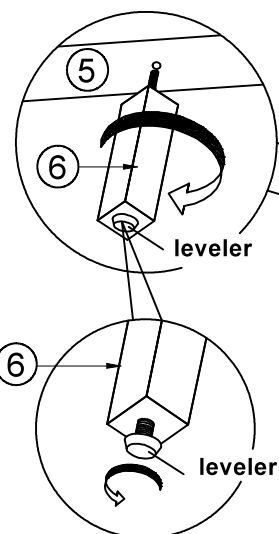

STEP 3.3 :

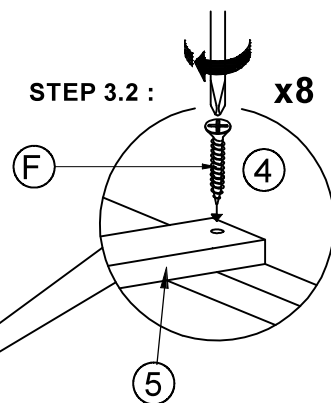

Push the side rail(4) meet with wooden slat(5) and fix the CSK screw (F) by using the Screw Driver.