

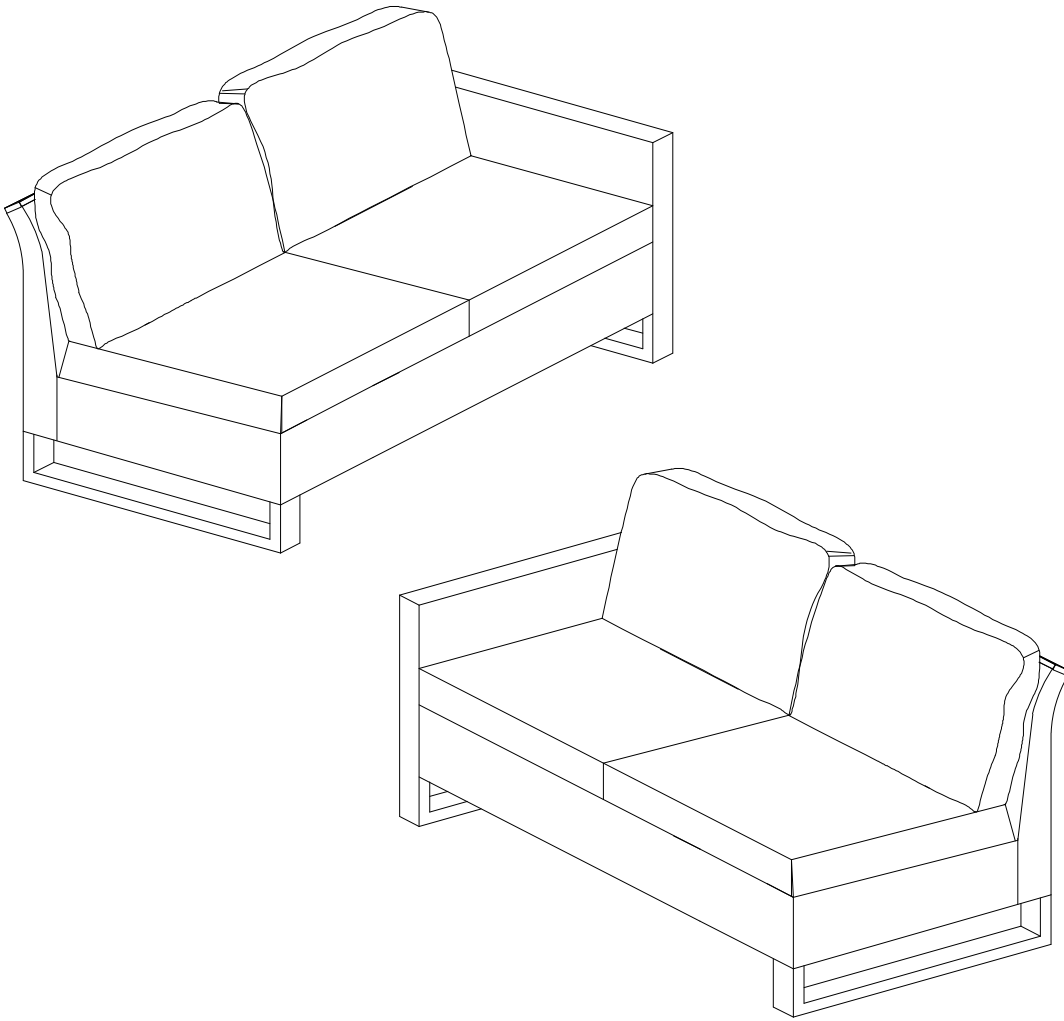

Assembly Instructions



***Don't fully tighten all the bolts till the very end!**

PRE-ASSEMBLY PREPARATION:

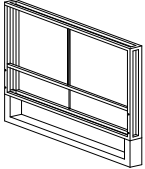
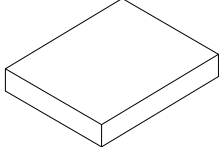
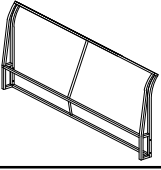
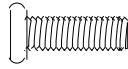
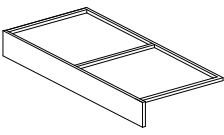
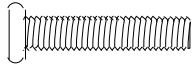
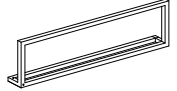
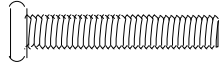
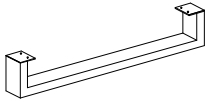
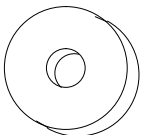
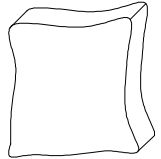
- Please read through the instructions before beginning assembly.
- Clear out the space for assembly and lay out all of the parts based on the Parts List, extra room will allow you to easily determine if all the pieces are present.
- Keep small parts and pieces away from children until fully assembled.



Part no.	Part	QTY	Image	Part no.	Part	QTY	Image
A	Arm (reversible)	1		G	Seat cushion	2	
B	Back	1		H	Bolt (M6*20mm)	4	
C	Seat	1		I	Bolt (M6*35mm)	8	
D	Seat side panel	1		J	Bolt (M6*40mm)	3	
E	Foot	1		K	Washer M6	15	
F	Back cushion	2		L	Allen wrench	1	

Step 1: This arm is reversible.

If you need the sofa with right arm, please attach arm A to back B on the right, with 2pcs bolts I and 2pcs washers K, using Allen wrench L.

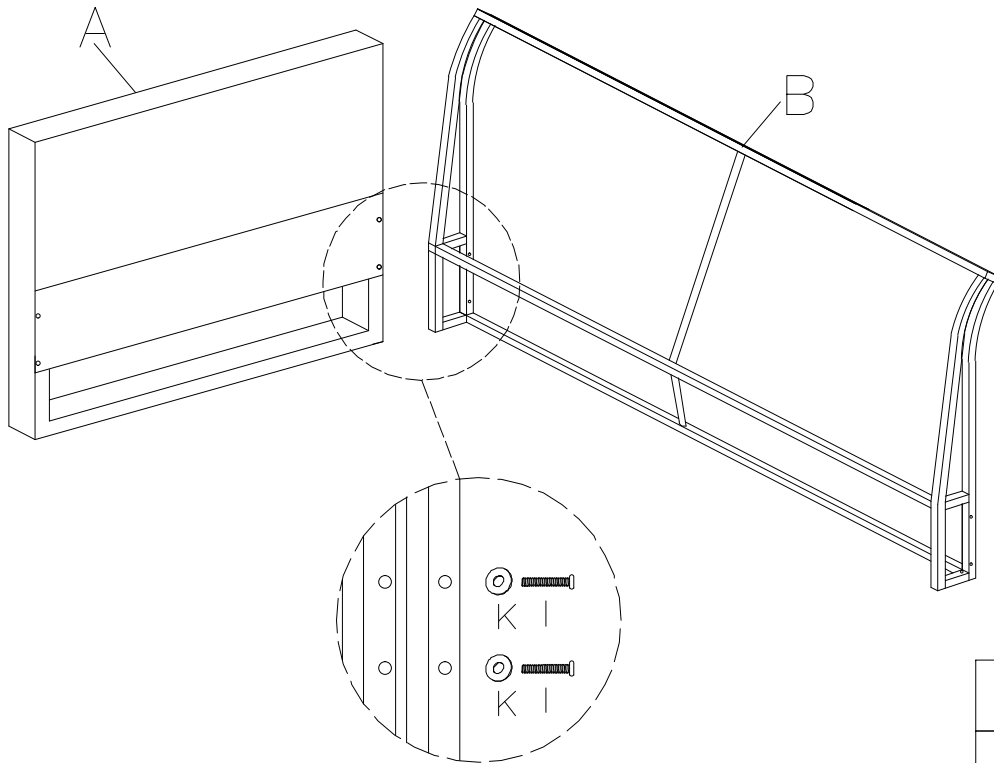
Note: Don't fully tighten the bolts.





I		M6*35	2
K		M6	2

If you need the sofa with left arm, please attach arm A to back B on the left, with 2pcs bolts I and 2pcs washers K, using Allen wrench L.

Note: Don't fully tighten the bolts.

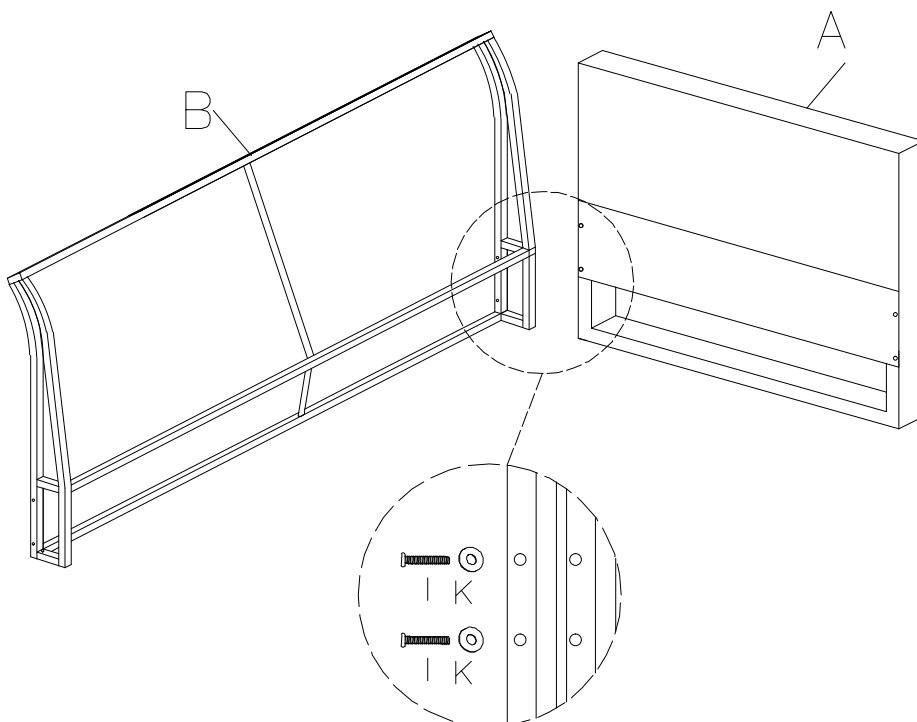

The NEXT assembly steps are same as the sofa with right arm.



I		M6*35	2
K		M6	2

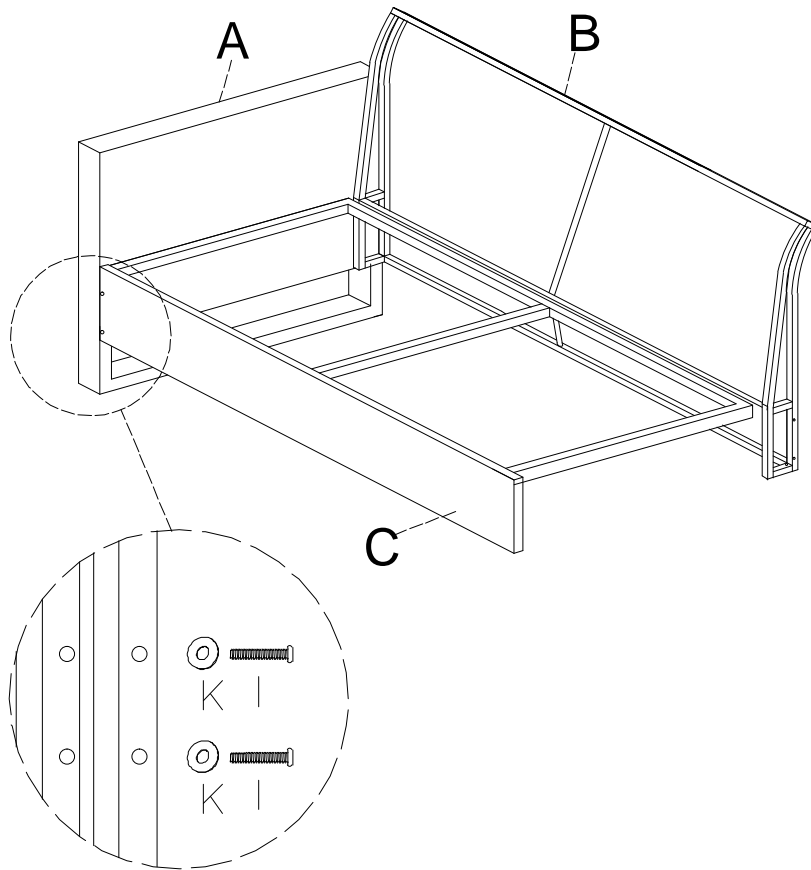

Step 2: Attach seat C to arm A with 2pcs bolt I and 2pcs washer K, using Allen wrench L. Note: Don't fully tighten the bolts.



I		M6*35	2
K		M6	2

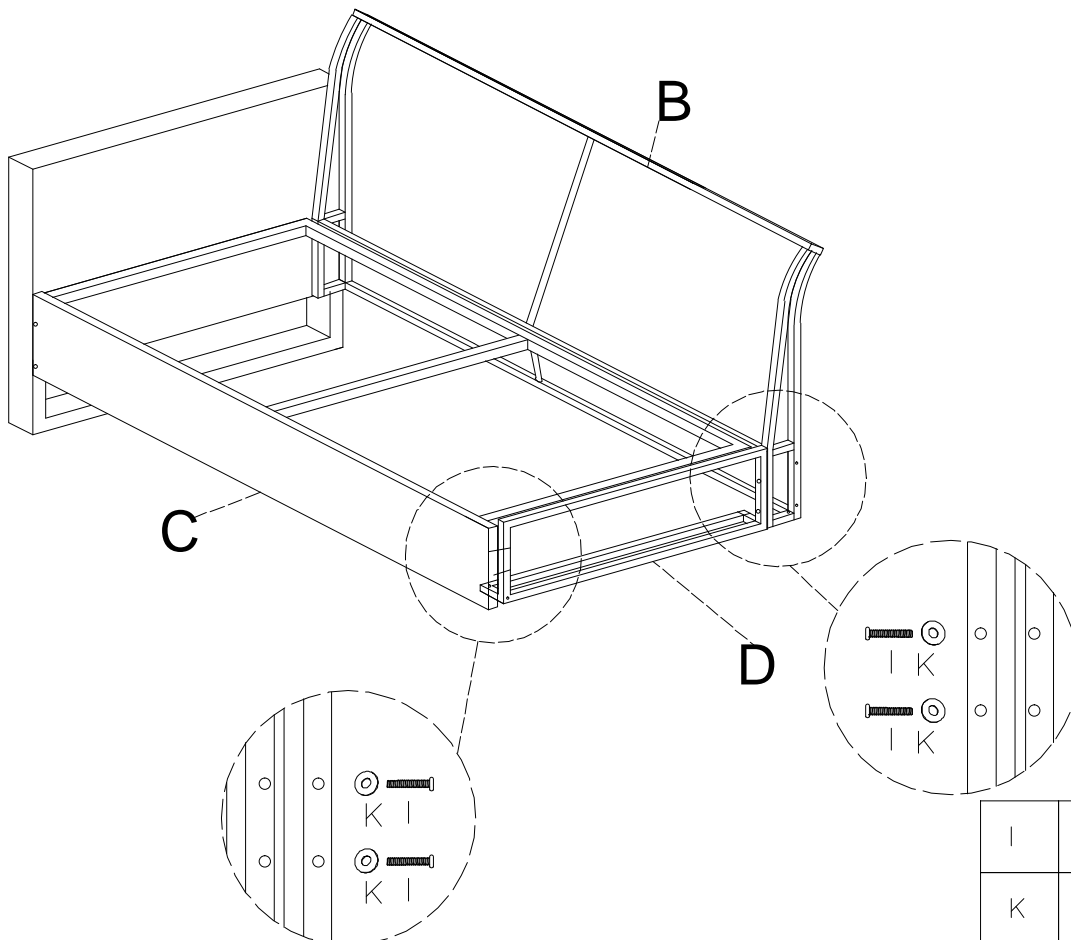

Step 3: Attach seat side panel D to back B and seat C with 4pcs bolt I and 4pcs washer K, using Allen wrench L. Note: Don't fully tighten the bolts.



I		M6*35	4
K		M6	4

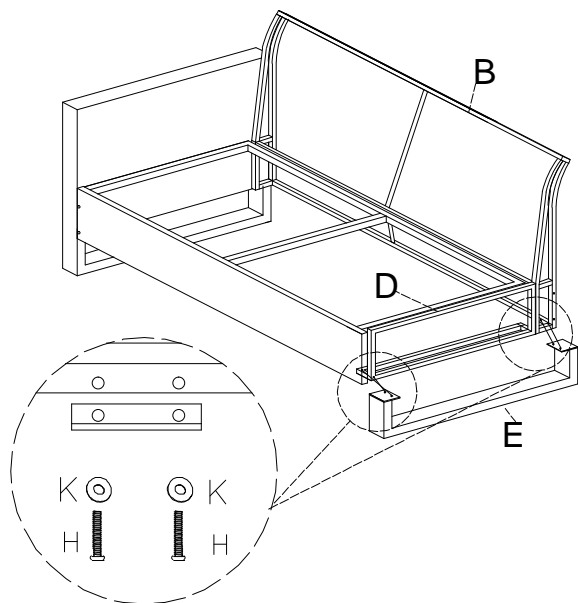

Step 4: Attach foot E to part B&D with 4pcs bolts H and 4pcs washers K, using Allen wrench L. Note: Don't fully tighten the bolts.

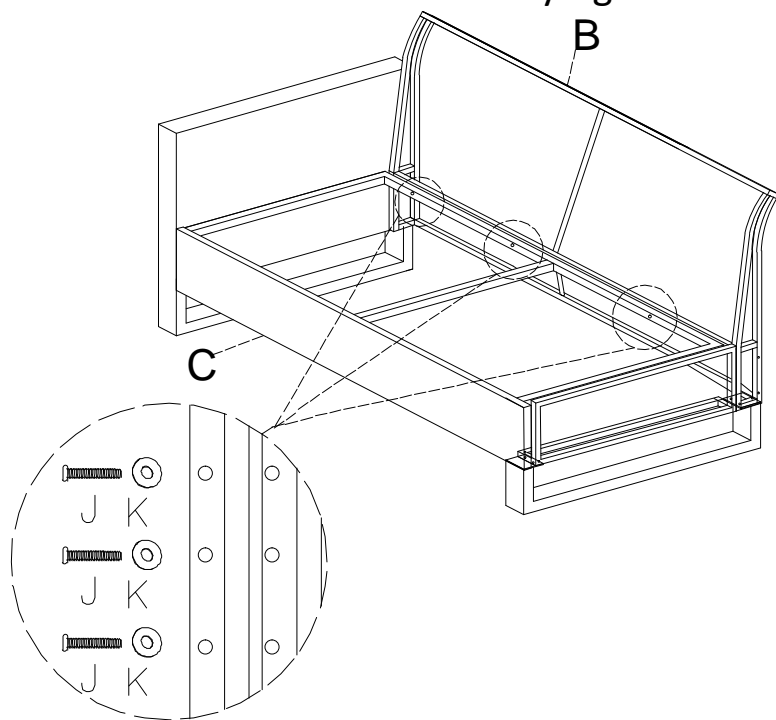

H		M6*20	4
K		M6	4

Step 5: Attach seat C to back B with 3pcs bolts J and 3pcs washers K, using Allen wrench L. Note: Please fully tighten all the bolts.



J		M6*40	3
K		M6	3

Step 6: Put seat cushions G and back cushions F onto the seat. Assembly is now complete and the product is ready for use.

