

Coffee Table

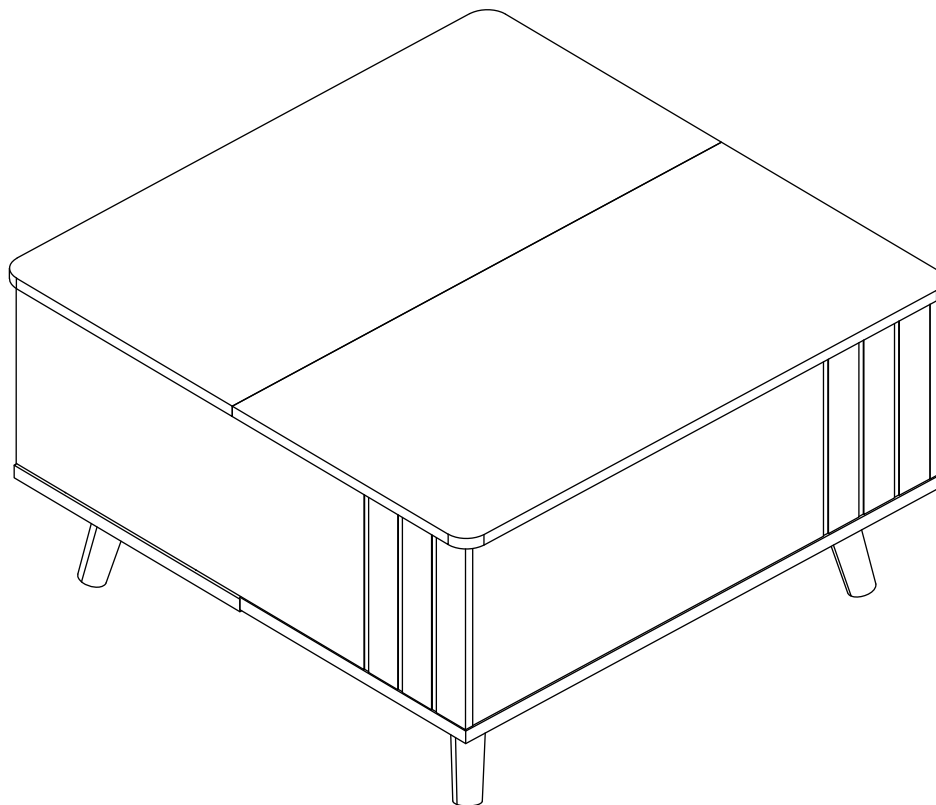

Please make sure to read the instruction manual carefully before installing the product.

Do Not Return This Product!

Contact our customer service team
for help first.

WARNING

- Unit can tip over causing severe injury or death.
- Anchor unit to stud in wall (if instructed to)
- Do Not allow children to climb on unit.
- put heavy items on lower shelves or drawers.

**PEOPLE NEEDED
FOR ASSEMBLY: 2**

CONTACT US!

Do NOT return this product!

Contact our friendly customer service team first for help.

- Open your item in the area you plan to keep it to avoid excessive heavy lifting.
- Identify, sort and count the parts before attempting assembly.
- Back panel must be used to make sure your unit is sturdy.
- Do NOT use harsh chemicals or abrasive cleaners on this item.
- Never push,pull,or drag your furniture.



BEFORE YOU START

- Read through each step carefully and follow the proper order
- Separate and count all your parts and hardware
- Give yourself enough room for the assembly process
- Have the following tools:Flat Head Screwdriver,#2 Phillips Head Screwdriver and Hammer
- Caution: IF using a power drill or power screwdriver for screwing,please be aware to slow down and stop when screw is tight.Failure to do so may result in stripping the screw.



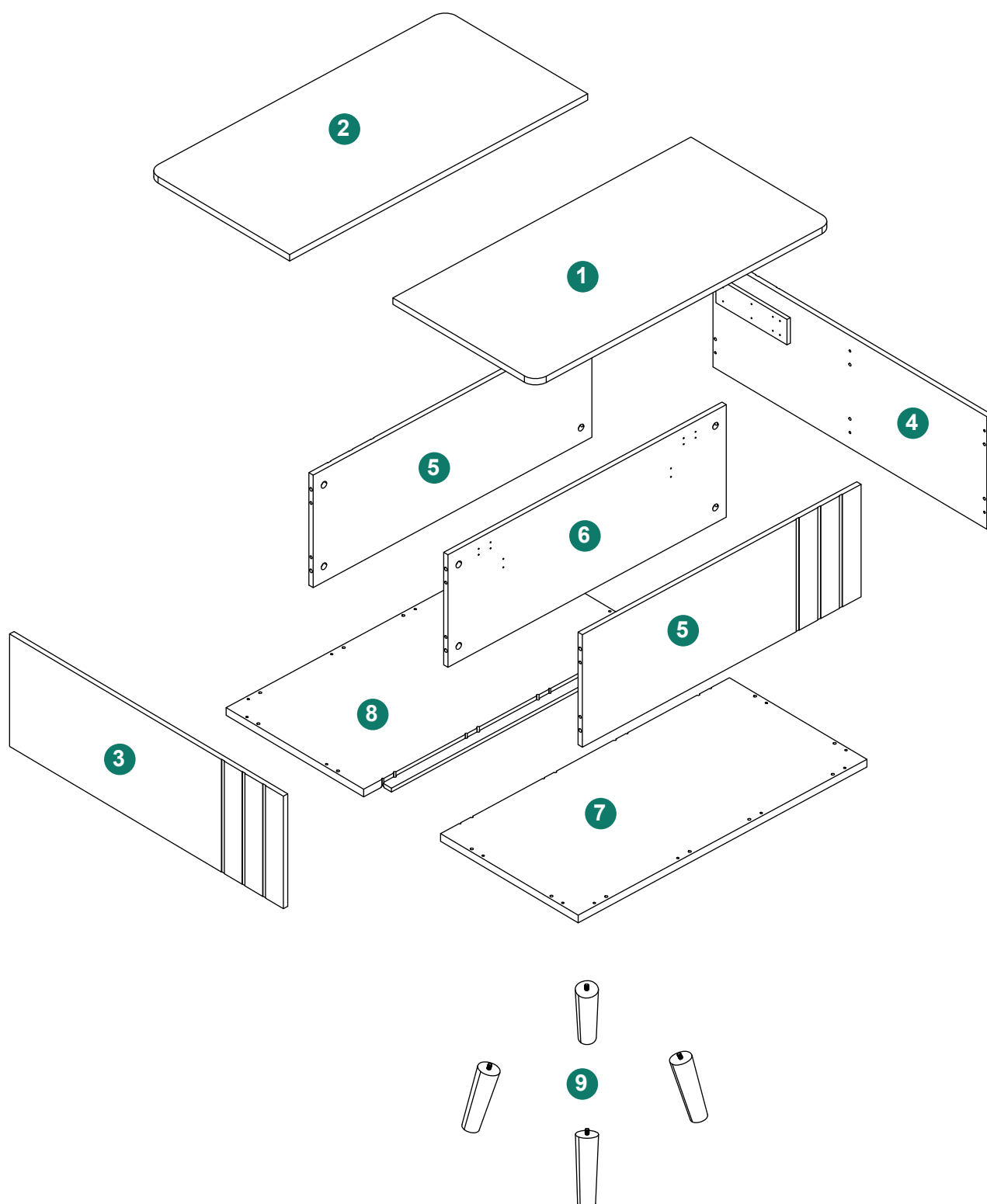



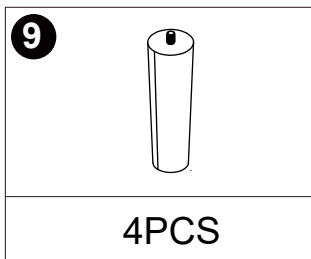
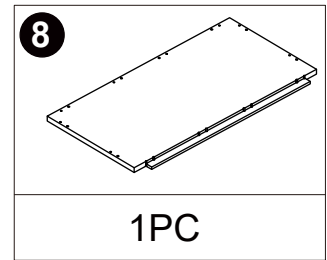
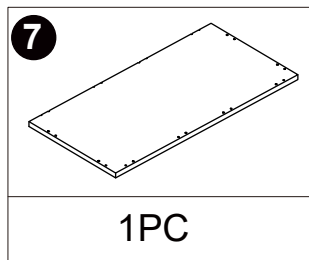
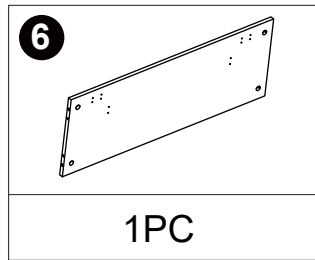
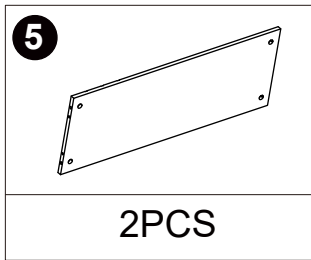
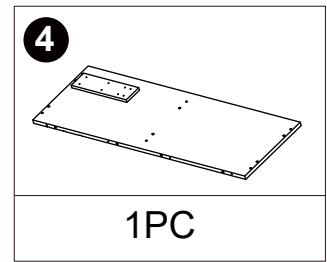
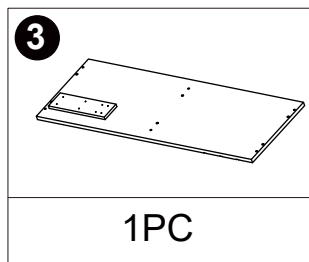
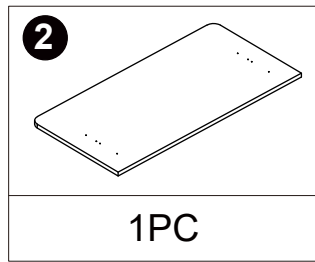
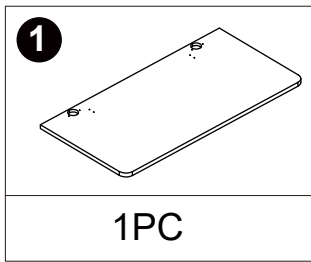



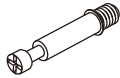

BOARD IDENTIFICATION

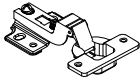
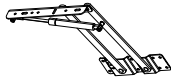
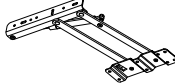

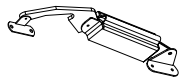
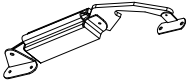
BOARD IDENTIFICATION

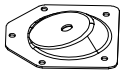

THE HARDWARE

A x12	B x12	C x32	D x20	E x12
				
Cam Bolt	Cam Lock	Wood Dowel	Screw	Screw
Ø6x35mm	Ø15x10mm	Ø6x30mm	Ø4x30mm	Ø4x12mm
F x2	G x1	H x1	I x24	J x1
				
Hinge	Left lift mechanism	Right lift mechanism	Screw	Spring Support Accessories
			Ø4x14mm	
K x1	L x8	M x12	N x8	O x4
				
Spring Support Accessories	Screw	Cam Cover	Buffer Pad	Angle Bracket
Ø3x12mm	Ø4x12mm			
P x20	Q x4			
				
Screw	Foot Screw			
Ø4x14mm				

IMPORTANT :

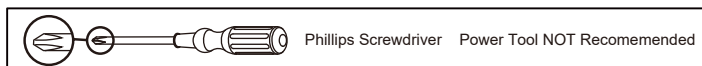

1. Do not tighten bolts / screws completely until all bolts / screws are lined up and inserted into holes.
2. Do not over tighten screws and bolts to avoid stripping.
3. Please use hand tools to assemble this product. Do not use power tools.

CAM LOCK FASTENING SYSTEM

This Cam Lock Fastening System will be used throughout the assembly process.

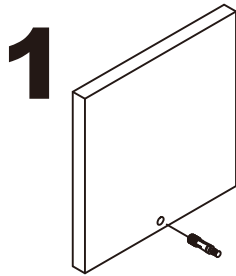

1
Press CAM BOLT into hole.

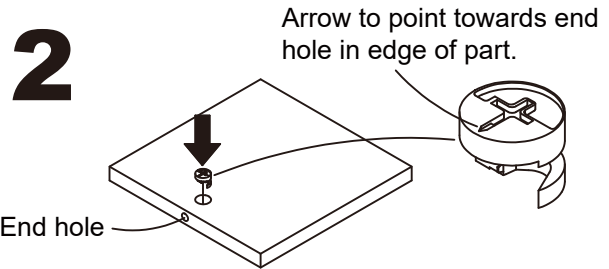

2
Press CAM LOCK into hole.

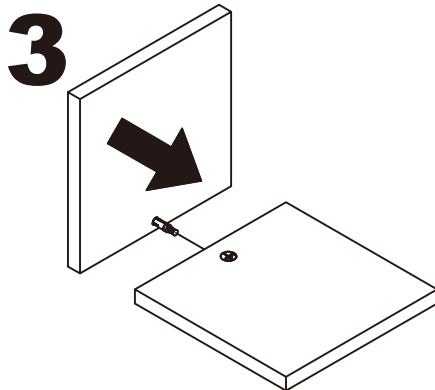

3
Press parts together so CAM BOLT inserts into edge hole.

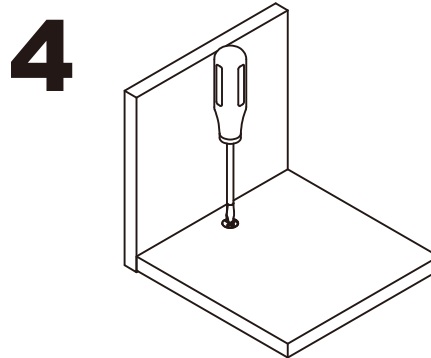

4
Using a screwdriver, turn the CAM LOCK clockwise to lock the CAM LOCK and CAM BOLT into their holes and fastening parts together.

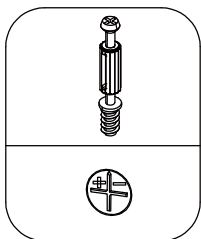

Notice: Proper orientation of CAM LOCK

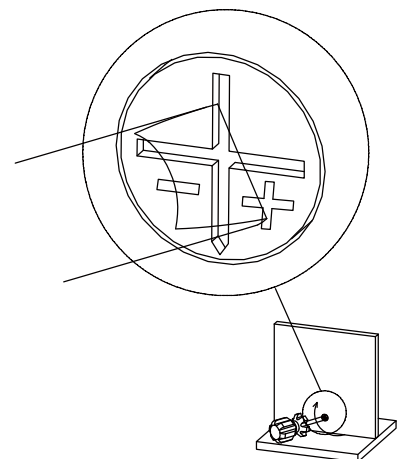
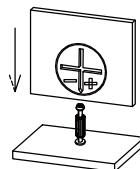
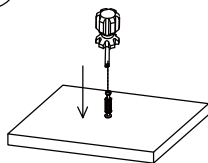
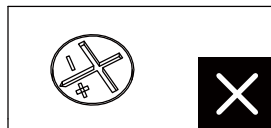
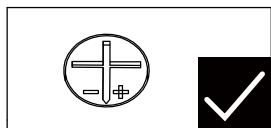

INSTALLATION STEPS

STEP 1

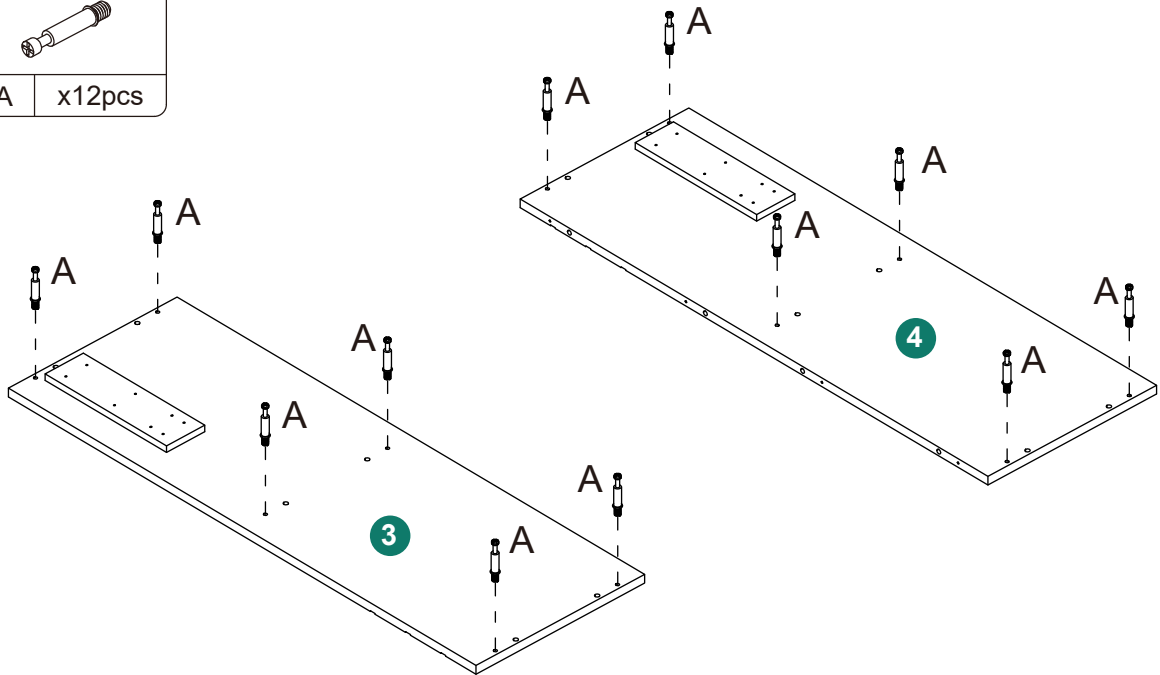
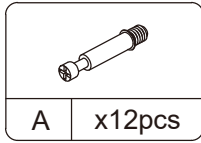

STEP 2

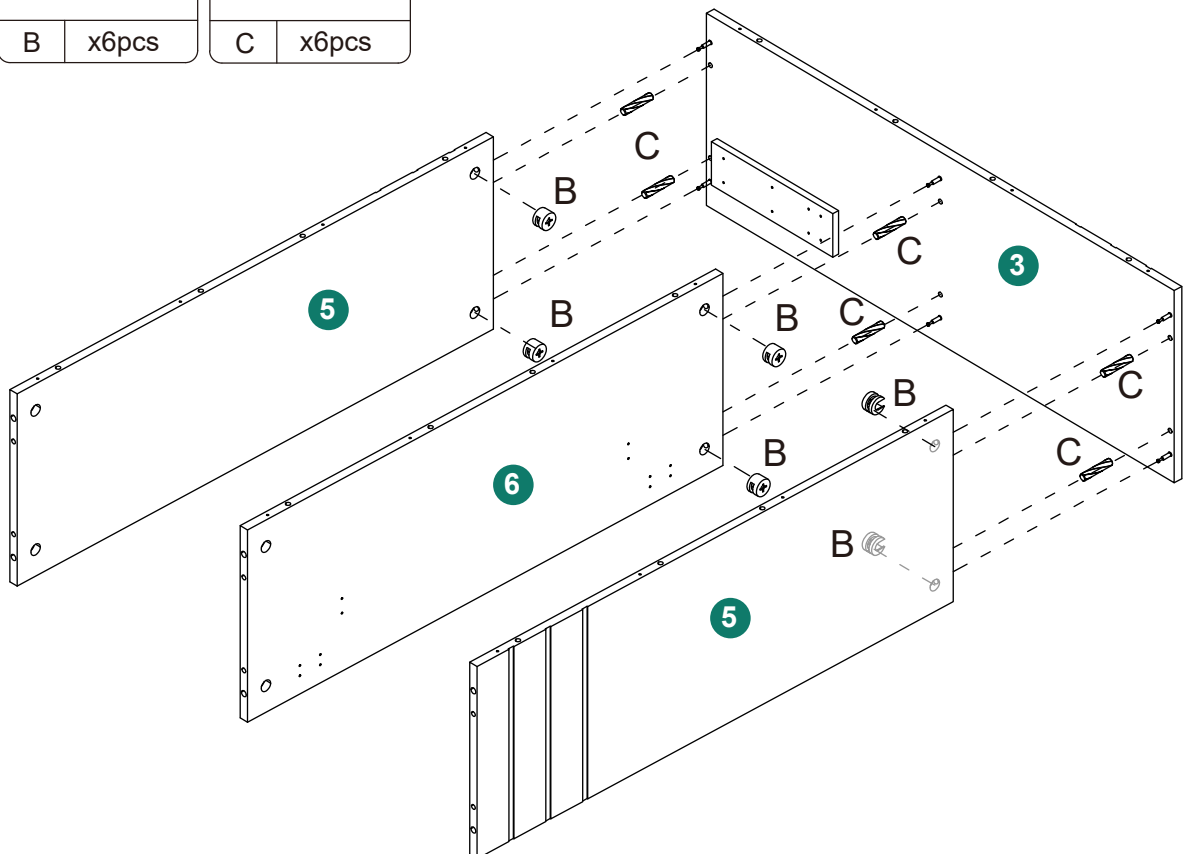
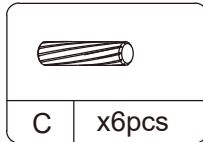

INSTALLATION STEPS

STEP 3

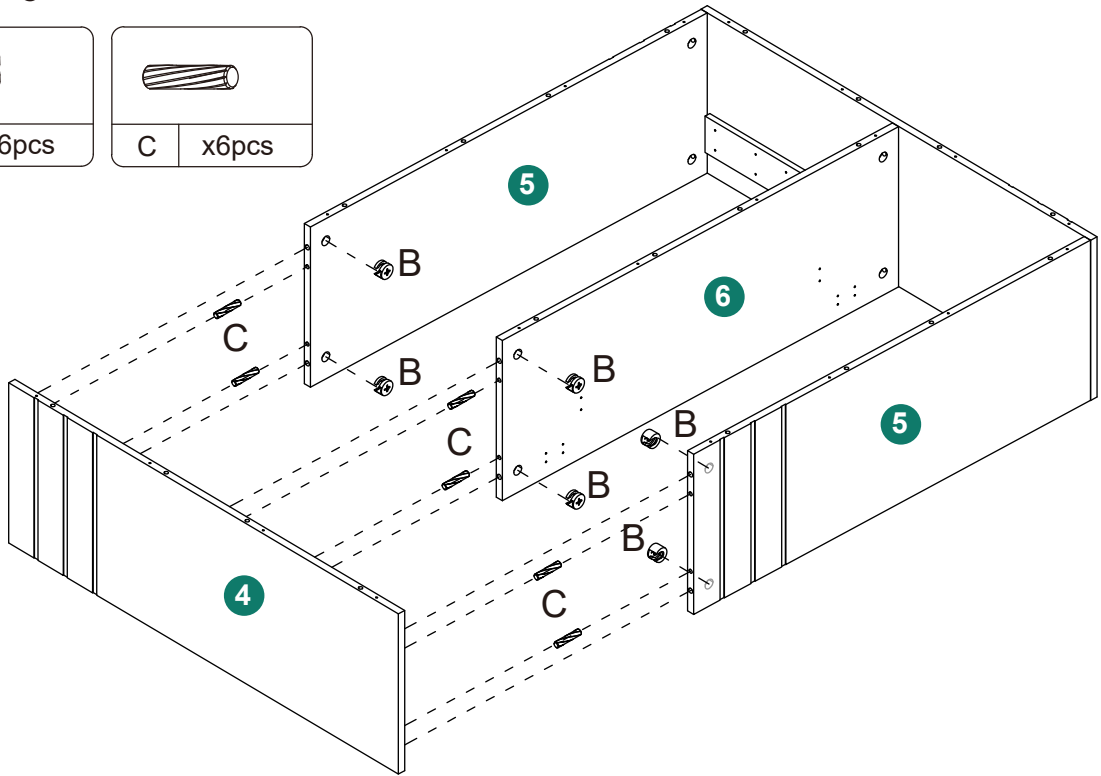
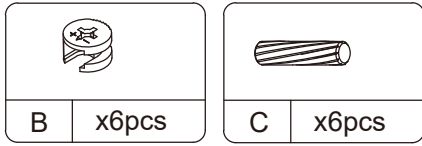

STEP 4

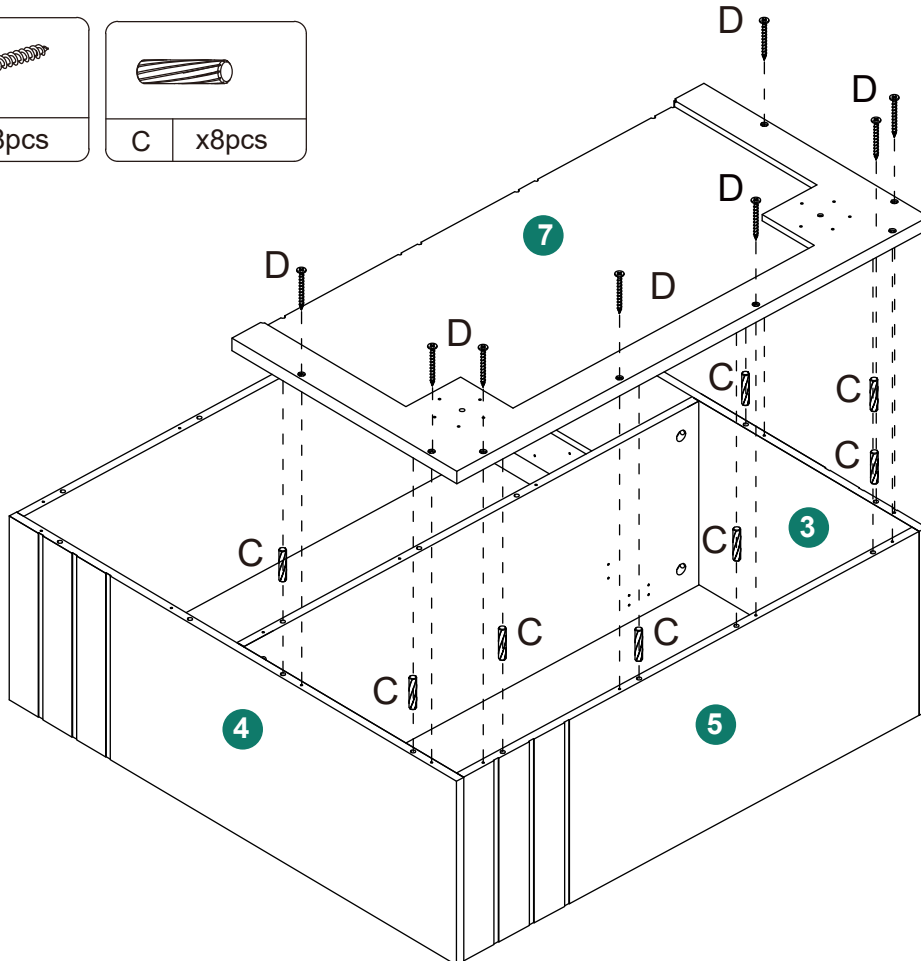
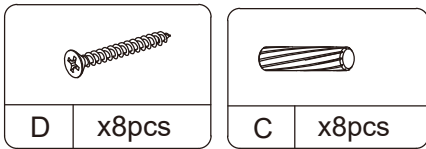

INSTALLATION STEPS

STEP 5

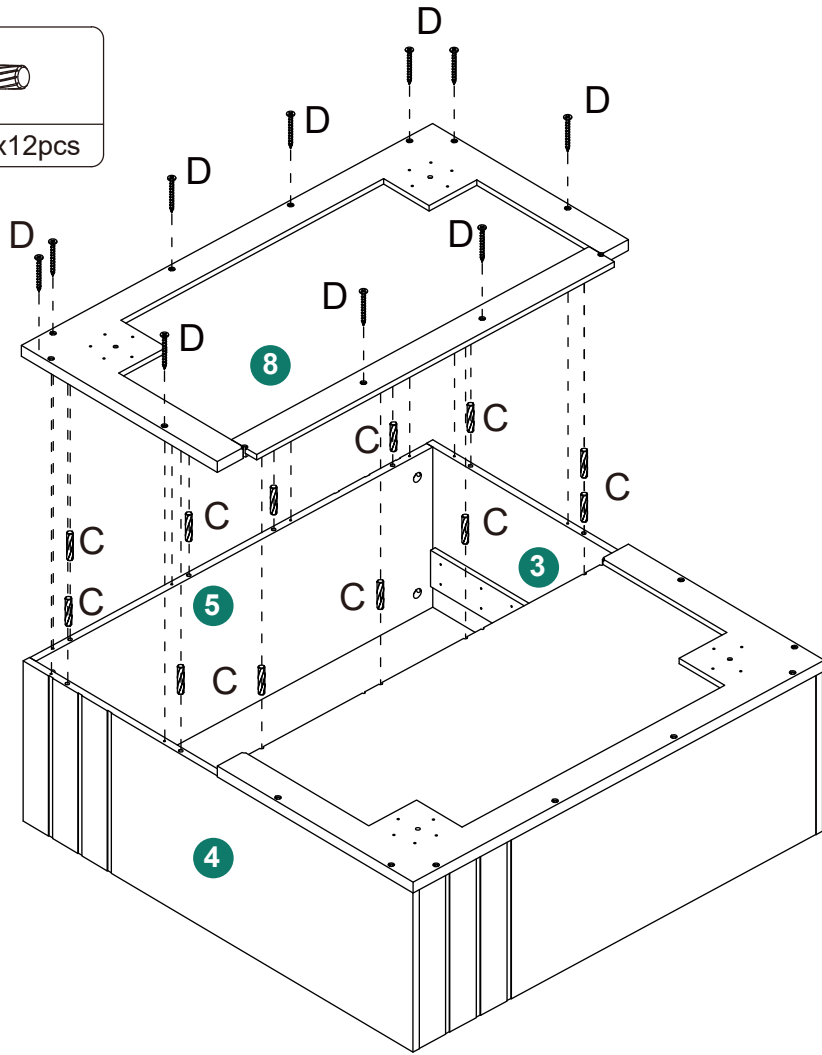
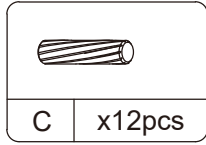
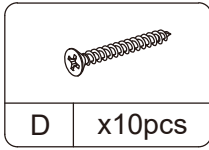

STEP 6

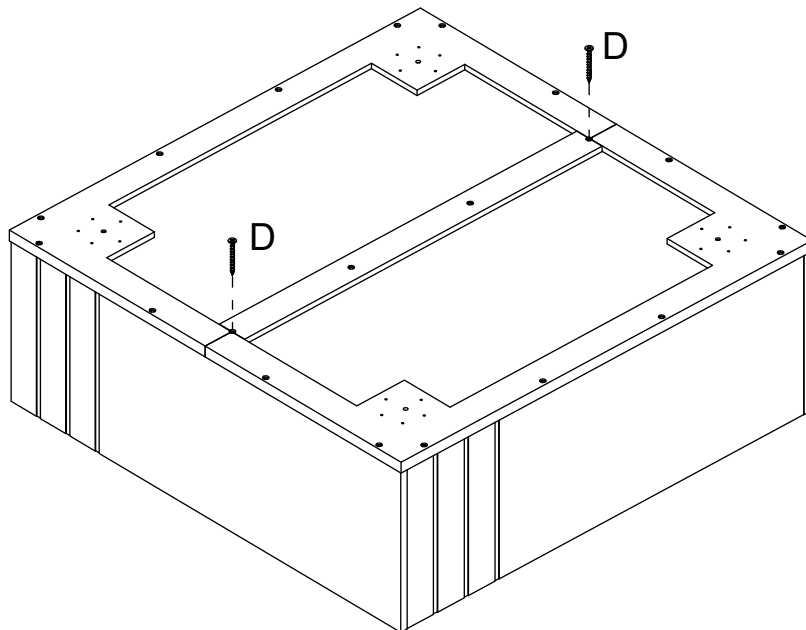
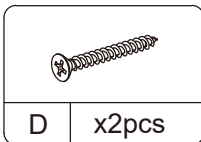

INSTALLATION STEPS

STEP 7

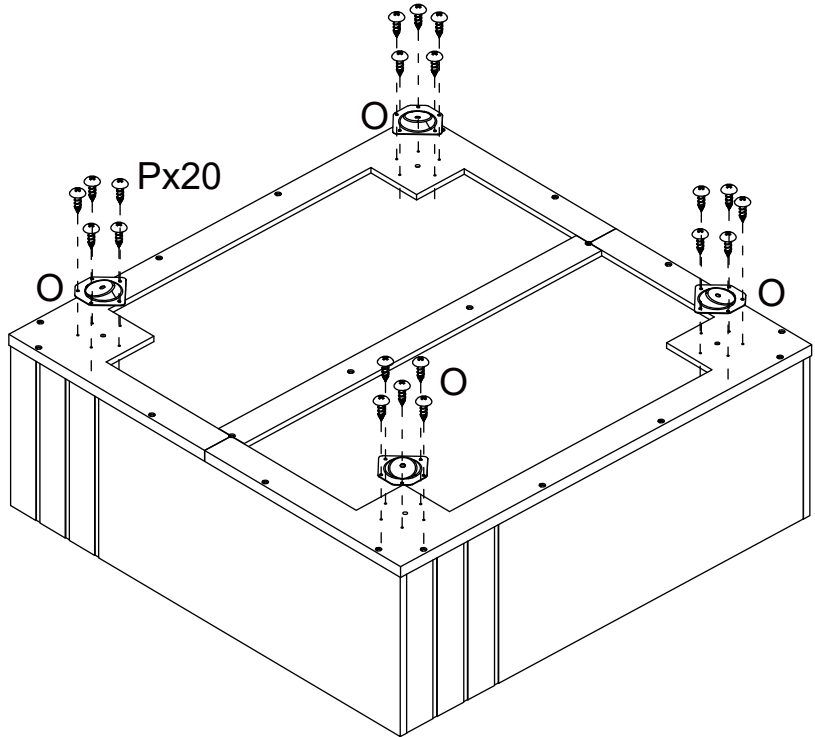
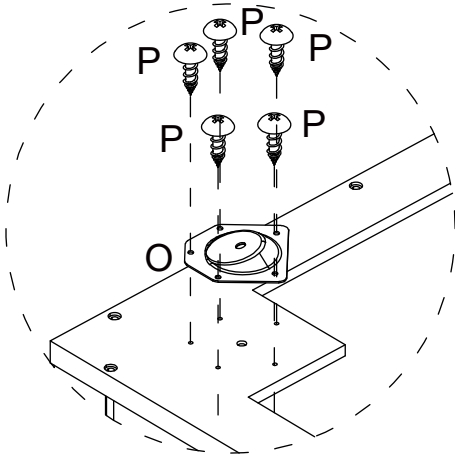
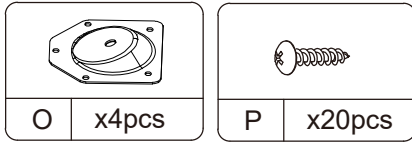

STEP 8

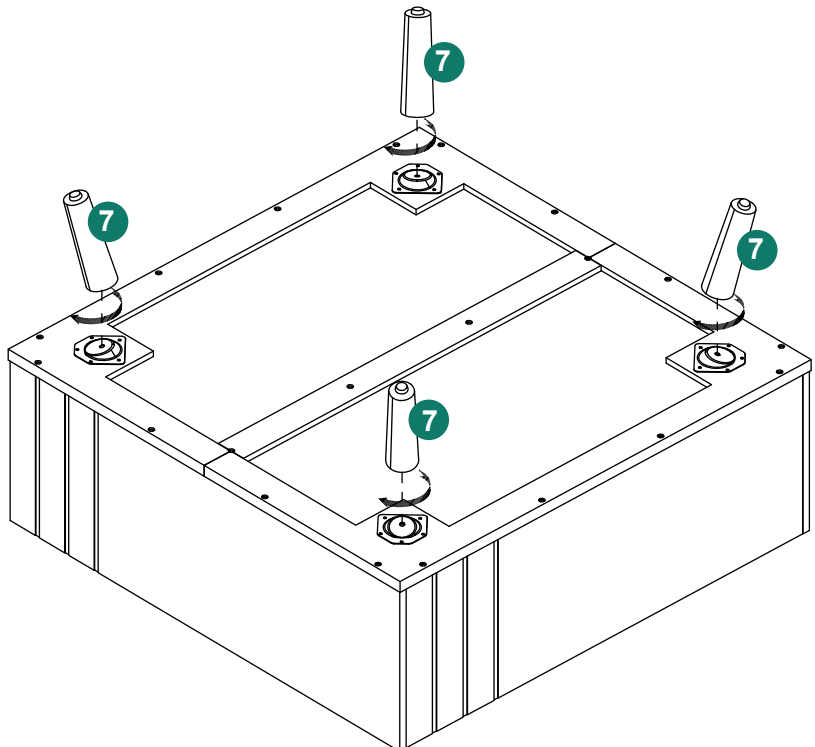
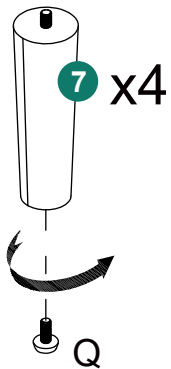
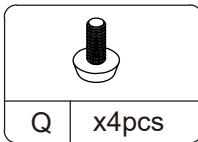

INSTALLATION STEPS

STEP 9

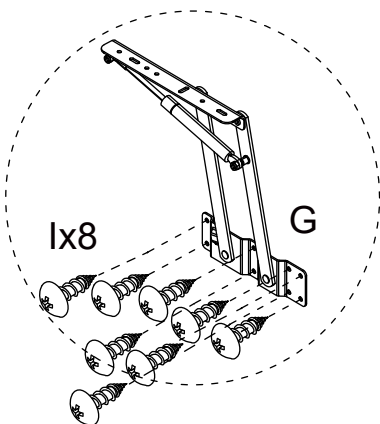
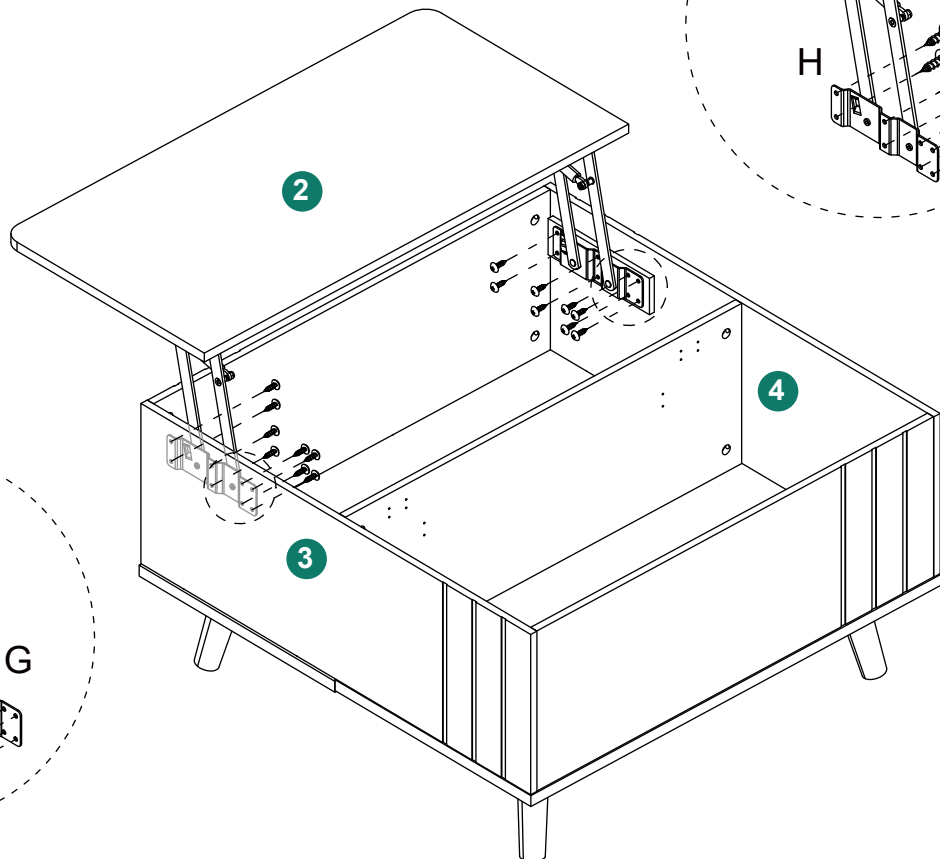
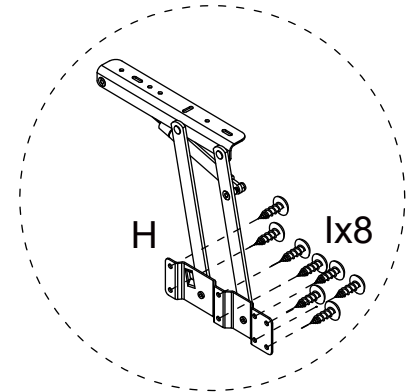
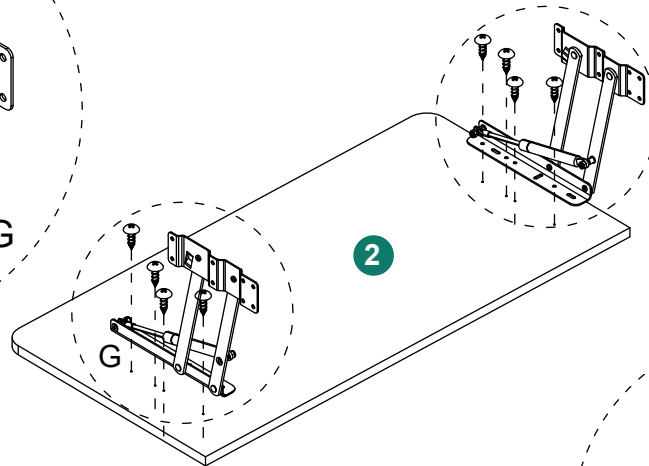
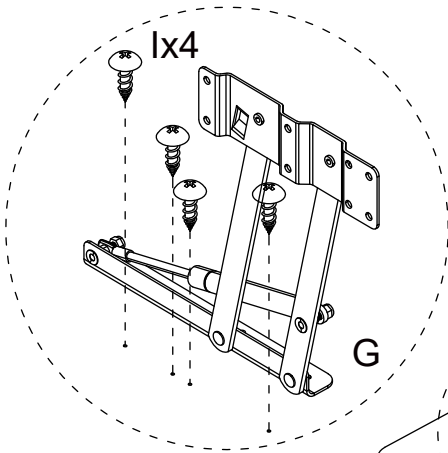
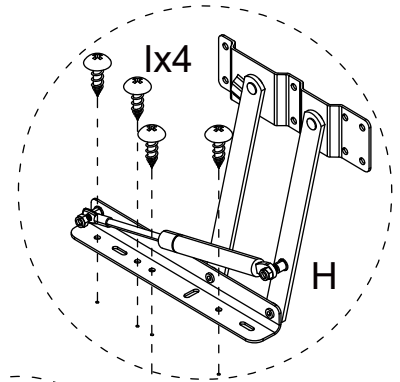
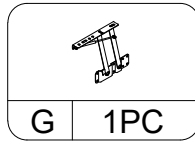
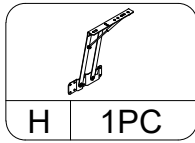
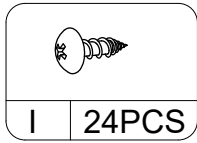

INSTALLATION STEPS

STEP 10

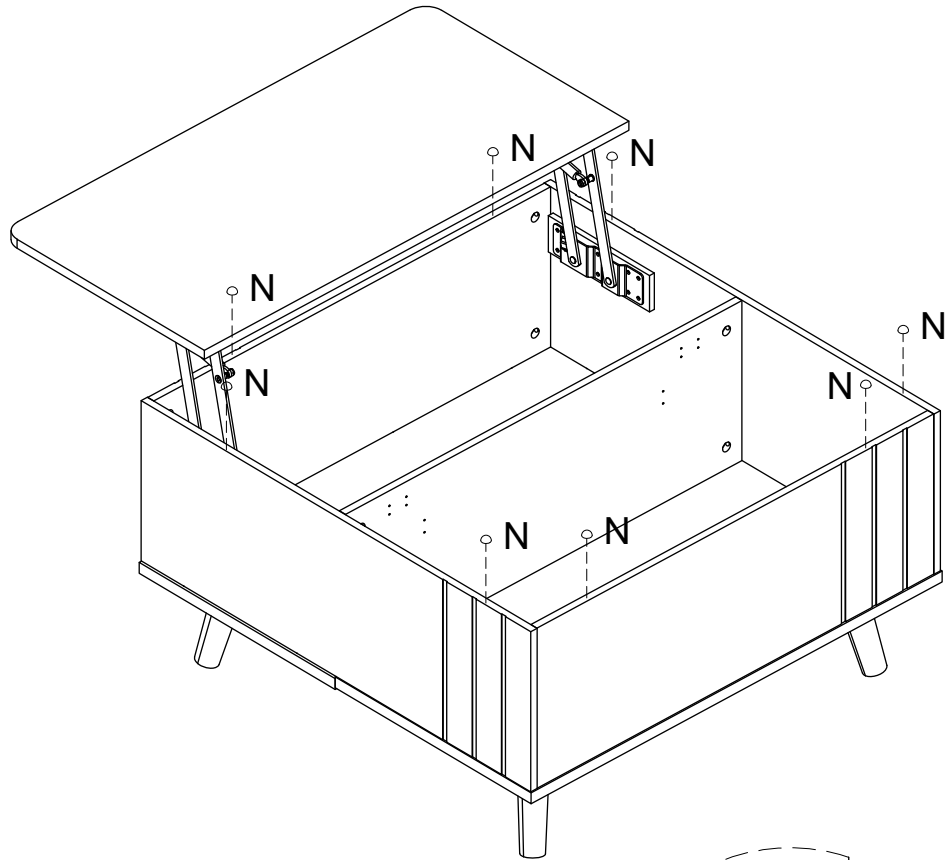
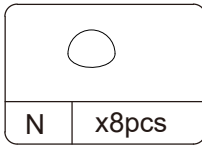

STEP 11

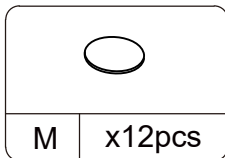

After installation, you can affix Cam Cover M to cover the Cam Lock Nuts on panels 5 and 6.

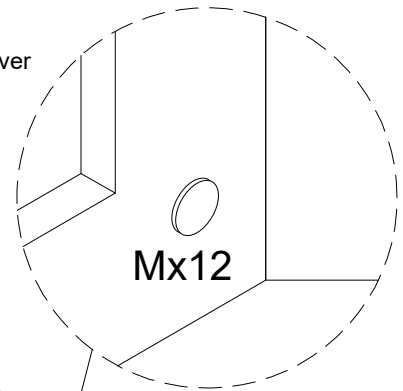
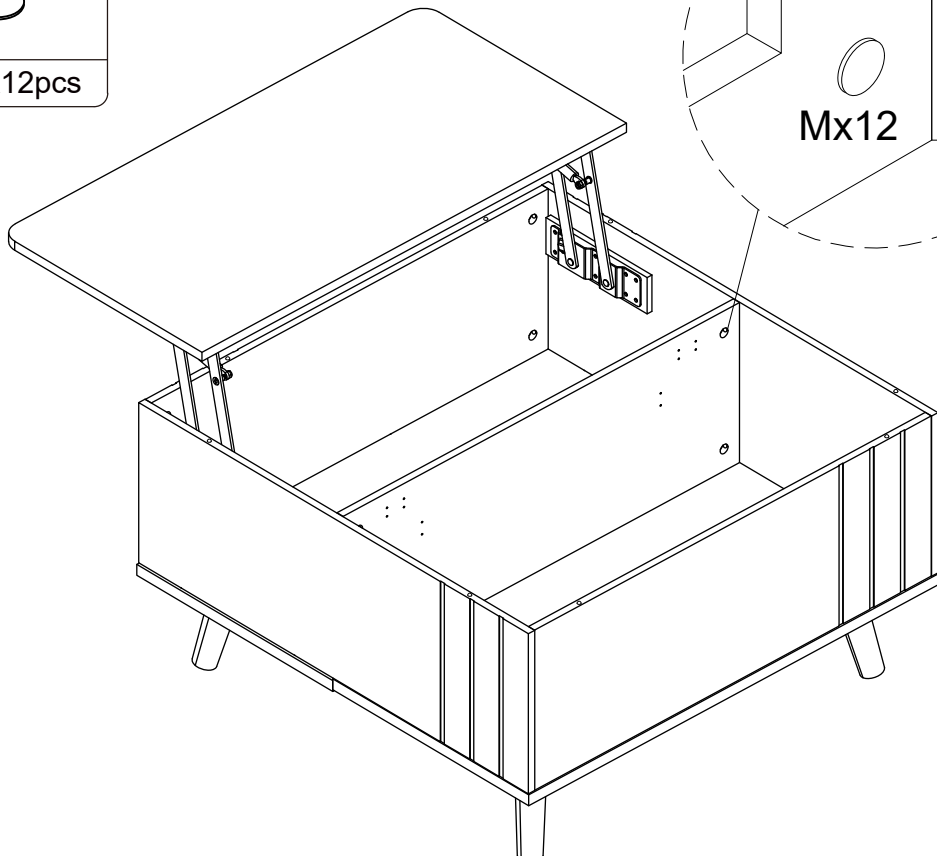

INSTALLATION STEPS

STEP 12

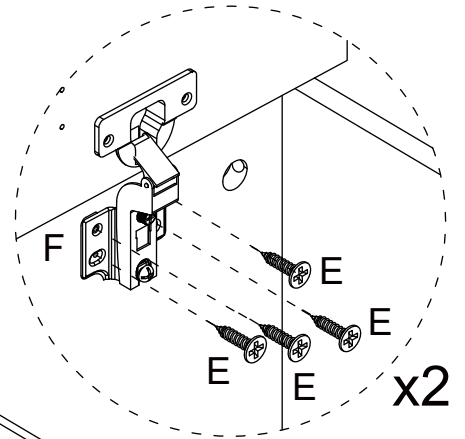
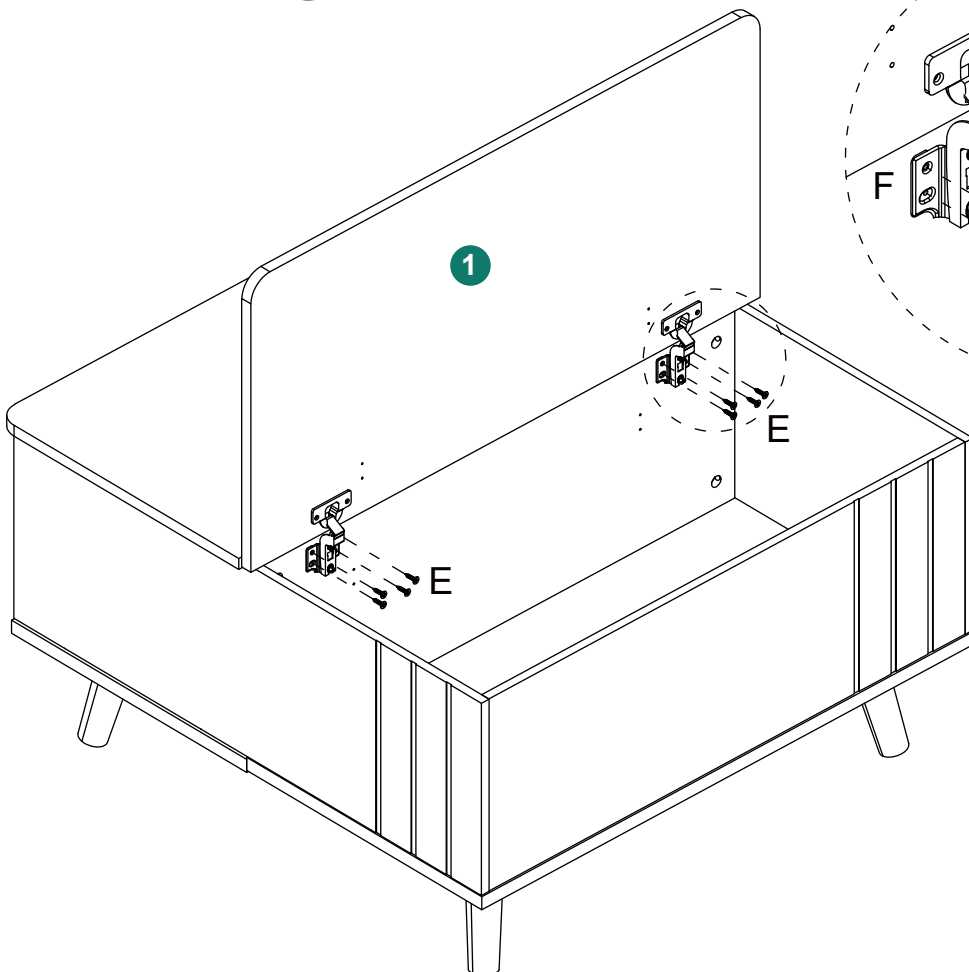
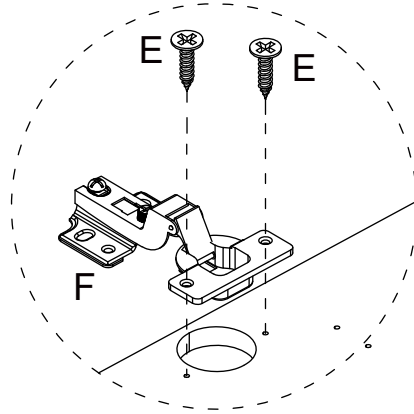
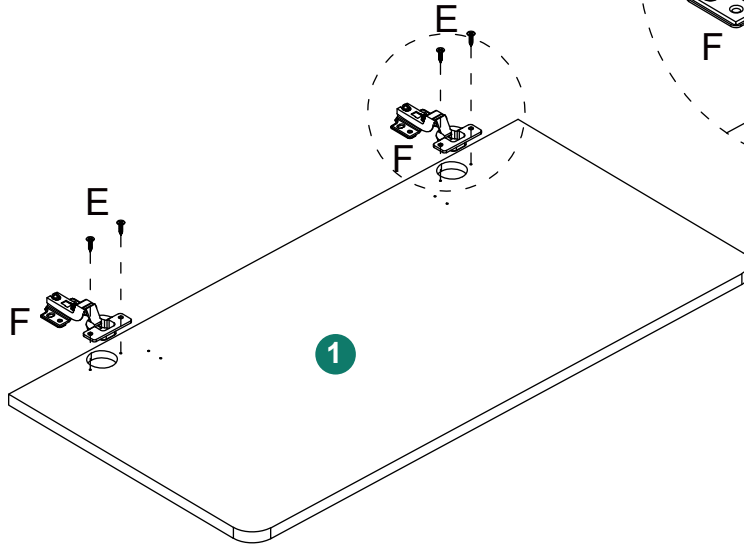
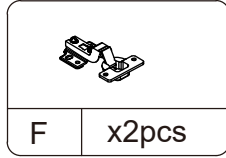
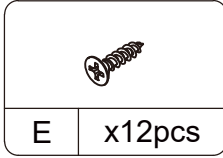

INSTALLATION STEPS

STEP 13

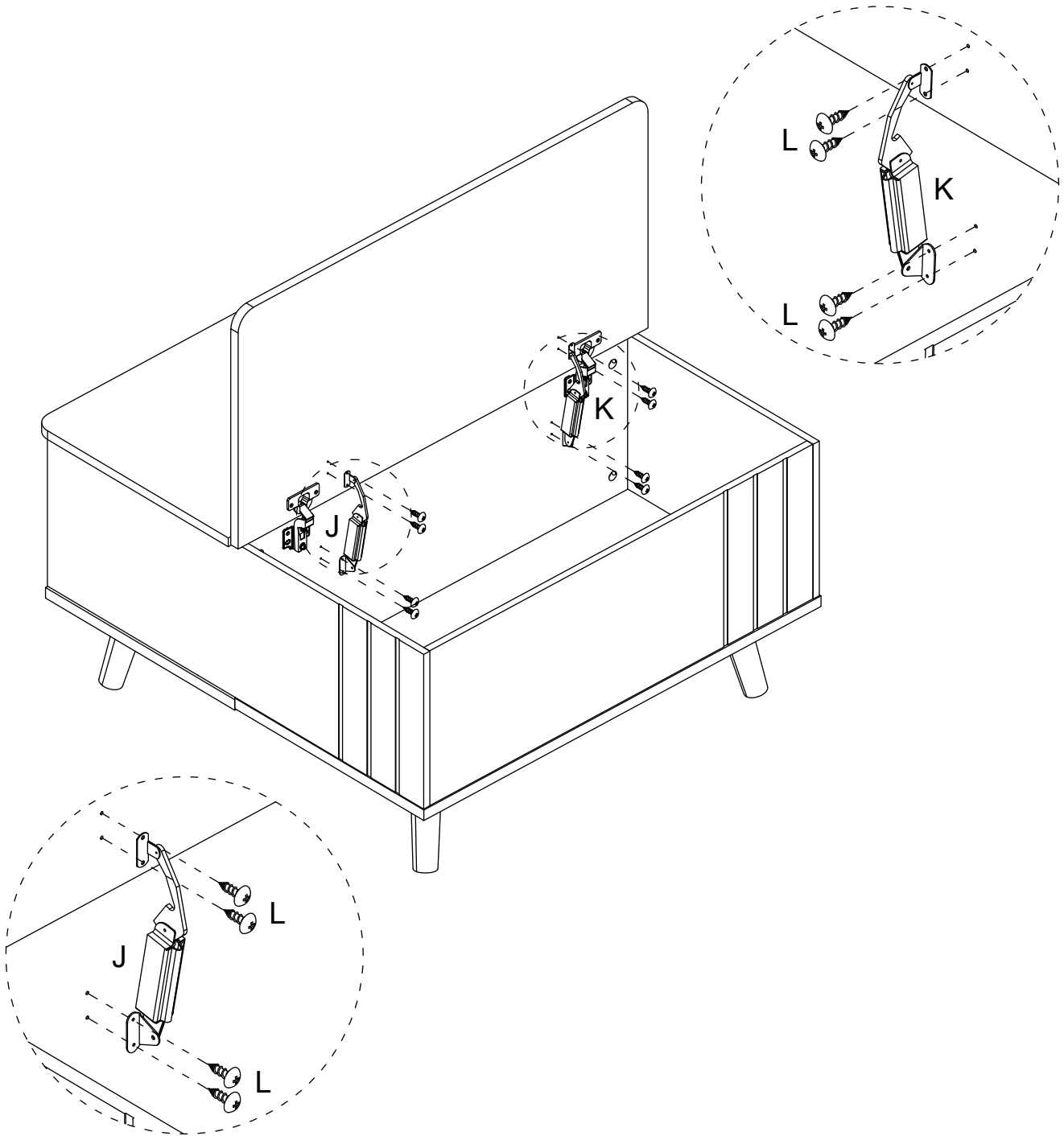
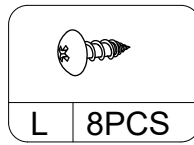
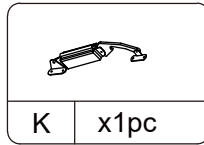
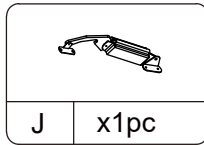

INSTALLATION STEPS



STEP 14

