

ASSEMBLY INSTRUCTION

QUEEN BED

IMPORTANT SAFETY NOTICE READ CAREFULLY BEFORE BEGINNING ASSEMBLY!

- * Before you begin, please read Assembly Instruction carefully and recognized the parts and hardware and follow the assembly step in order. Do not skip any steps.
- * Place parts on the carton while installing to prevent damage or scratches. Be sure to check all packing materials carefully for small parts may have come loose inside the cartoon during shipment. If parts are missing, contact the retailer from which your purchased the product to obtain any missing part. **DO NOT USE SUBTITUTE PART.**
- * Do not stand on tables, including but not limited to, end tables, coffee tables, and dinner tables, as tablesare not to support the weight of a person, use a step ladder in order to assembly upper item.
- * Where assembly instructions state that the assembly requires two or more people, do not attempt by yourself as there is a risk injury.

NOTE: GLORY FURNITURE DISCLAIMS ANY LIABILITY FOR DAMAGES OR INJURIES WHICH MAY OCCUR DUE TO FAILURE TO PROPERLY FOLLOW ASSEMBLY INSTRUCTION, PROPERLY ASSEMBLY THE PRODUCT, OR PROPERLY USE THE PRODUCT.

NOTE: YOUR UNIT MAY LOOK DIFFERENT IN APPEARANCE FROM THE ONE SHOWN IN THE ILLUSTRATIONS ON THE INSTRUCTION SHEET.

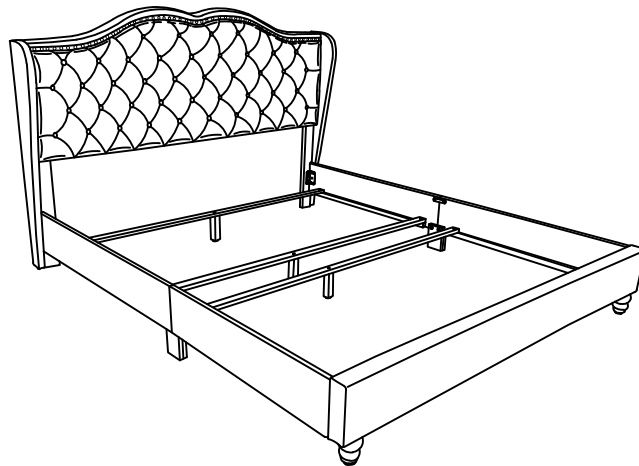

Required Tools : Screwdriver

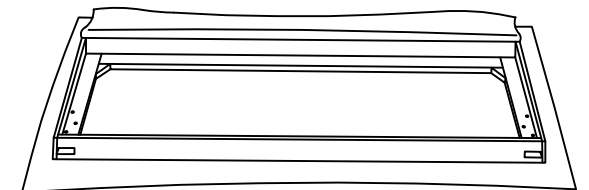
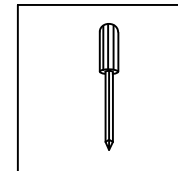

Please place on the carton while installing to prevent damage or scratches.

ASSEMBLY INSTRUCTION

QUEEN BED

ASSEMBLY PART

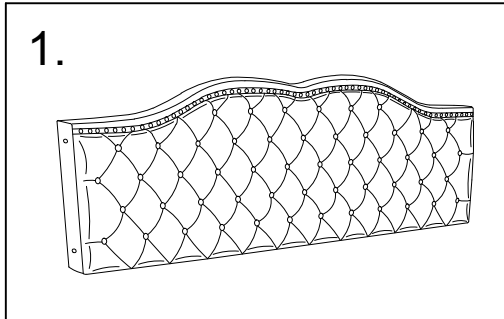

Headboard Panel 1 Pc

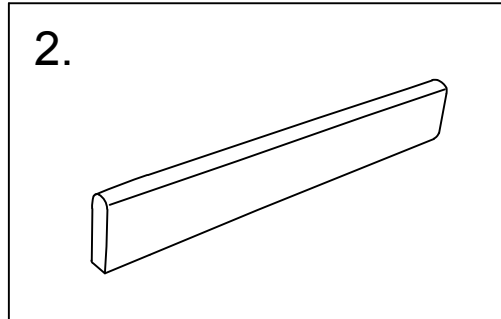

Footboard Panel 1 Pc

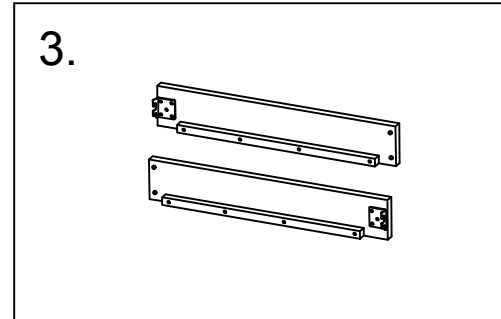

Side Rail Right 2 Pcs

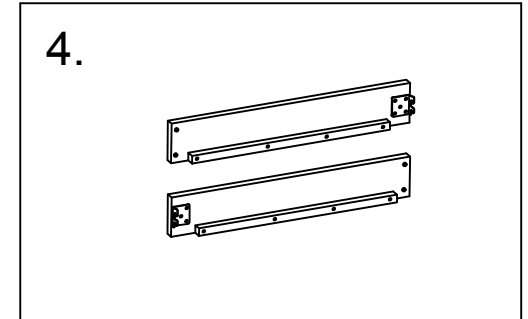

Side Rail Left 2 Pcs

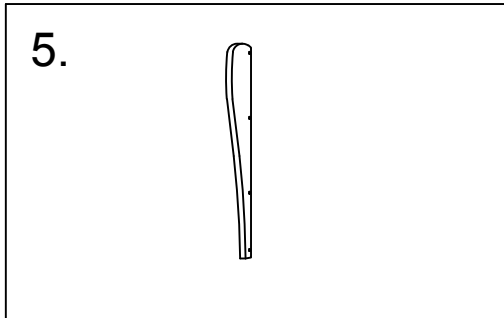

Left Wing 1 Pc

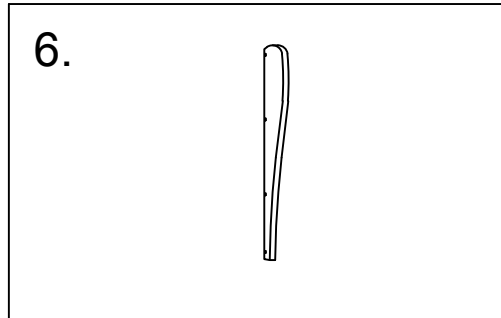

Right Wing 1 Pc

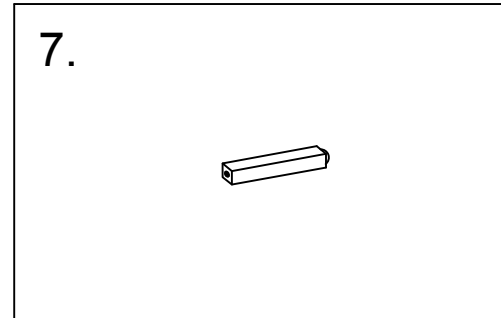

Support Leg 4 Pcs

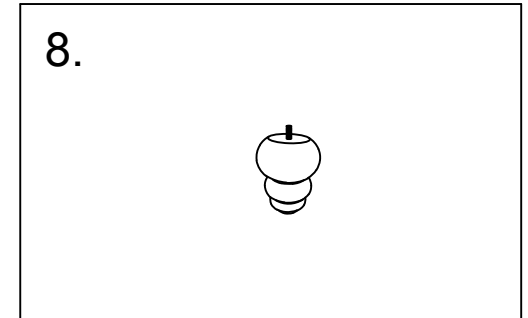

Footboard Leg 2 Pcs

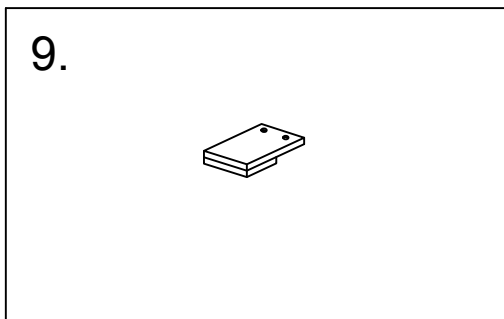

Side Rail Leg 2 Pcs

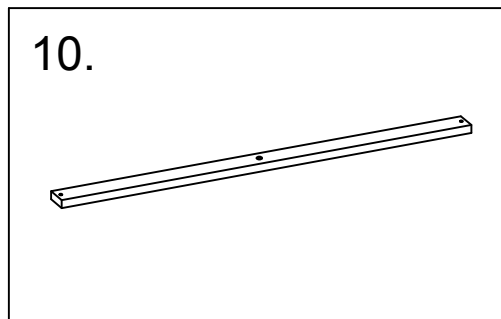

Slats 4 Pcs

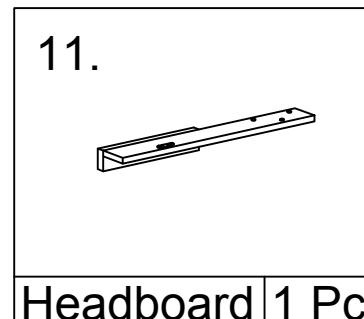

Headboard Left Leg 1 Pc

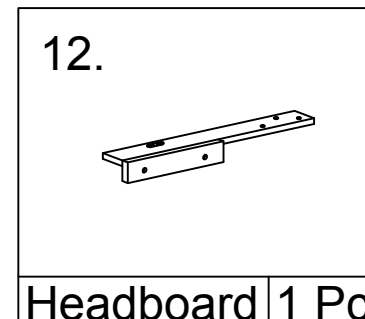



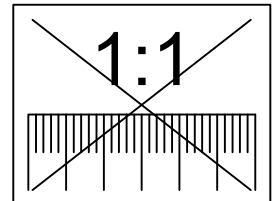







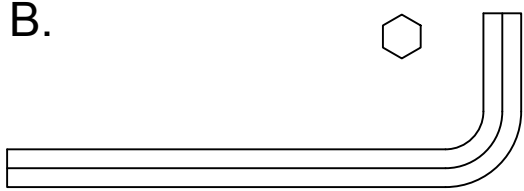

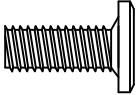

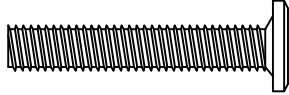
Headboard Right Leg 1 Pc

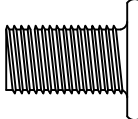
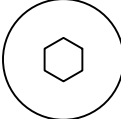

ASSEMBLY INSTRUCTION

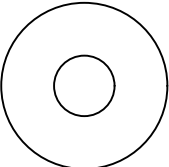
QUEEN BED

HARDWARE DESCRIPTION

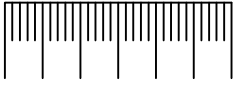
<p>A.</p> 	<p>B.</p> 	<p>C.</p> 					
<p>Allen Key M4</p>	<p>1 PC</p>	<p>Allen Key M5</p>	<p>1 PC</p>	<p>Side Rail Connect</p>	<p>2PCS</p>		
<p>D.</p>  	<p>E.</p>  	<p>F.</p>  	<p>G.</p>  				
<p>JCBC Bolt M6 x 15mm</p>	<p>4PCS</p>	<p>JCBC Bolt M6 x 35mm</p>	<p>8PCS</p>	<p>JCBC Bolt M6 x 40mm</p>	<p>14PCS</p>	<p>JCBB Bolt M8 x 16mm</p>	<p>8PCS</p>
<p>H.</p>  	<p>I.</p>  	<p>J.</p>  	<p>1:1</p> 				
<p>Spring Washer M6</p>	<p>22PCS</p>	<p>Flat Washer M8</p>	<p>18PCS</p>	<p>CBS Screw M4 x 32mm</p>	<p>8PCS</p>		

ASSEMBLY INSTRUCTION

QUEEN BED

STEP 1.

Open the cover cloth located begin the Headboard (1) and attach the Right Leg (12) & Left Leg (11) use JCBC Bolt (F), Spring Washer (H), Flat Washer (I) and Allen Key M4 (A) to fix.

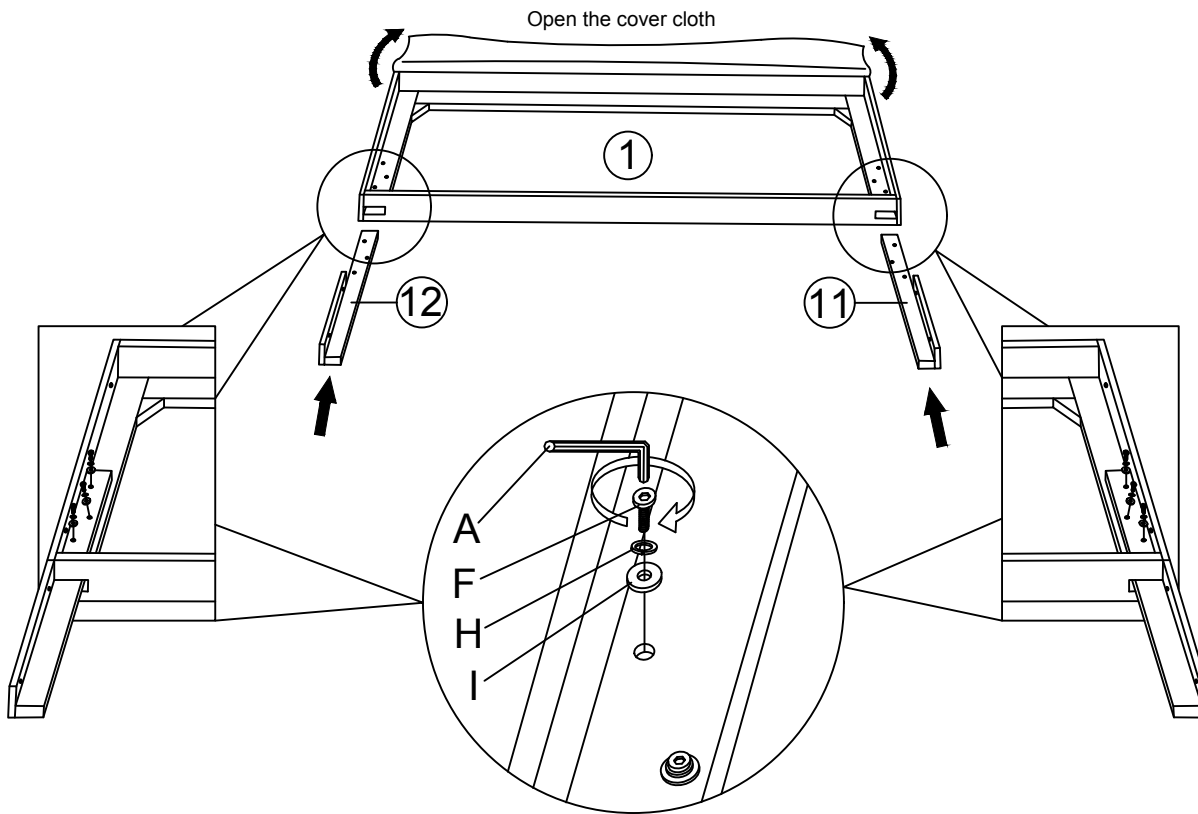

I - Flat Washer M8 - 6pcs

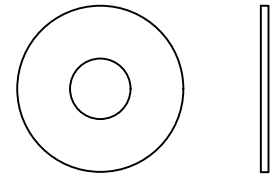

H - Spring Washer M6 - 6pcs



F - JCBC Bolt M6 x 40mm - 6pcs

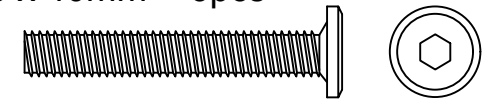

A - Allen Key M4 - 1pc

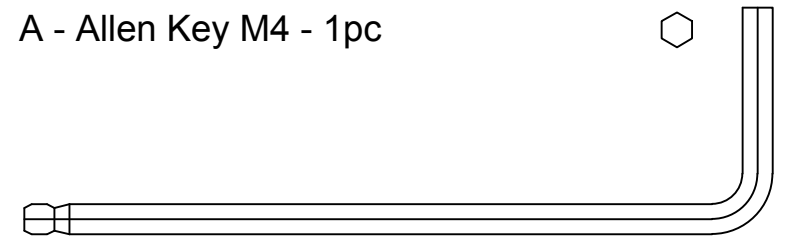

ASSEMBLY INSTRUCTION

QUEEN BED

STEP 2.

Attach the Slats (10) to Support Leg (7). Use JCBC Bolt (E) and Allen Key M4 (A) to fix.

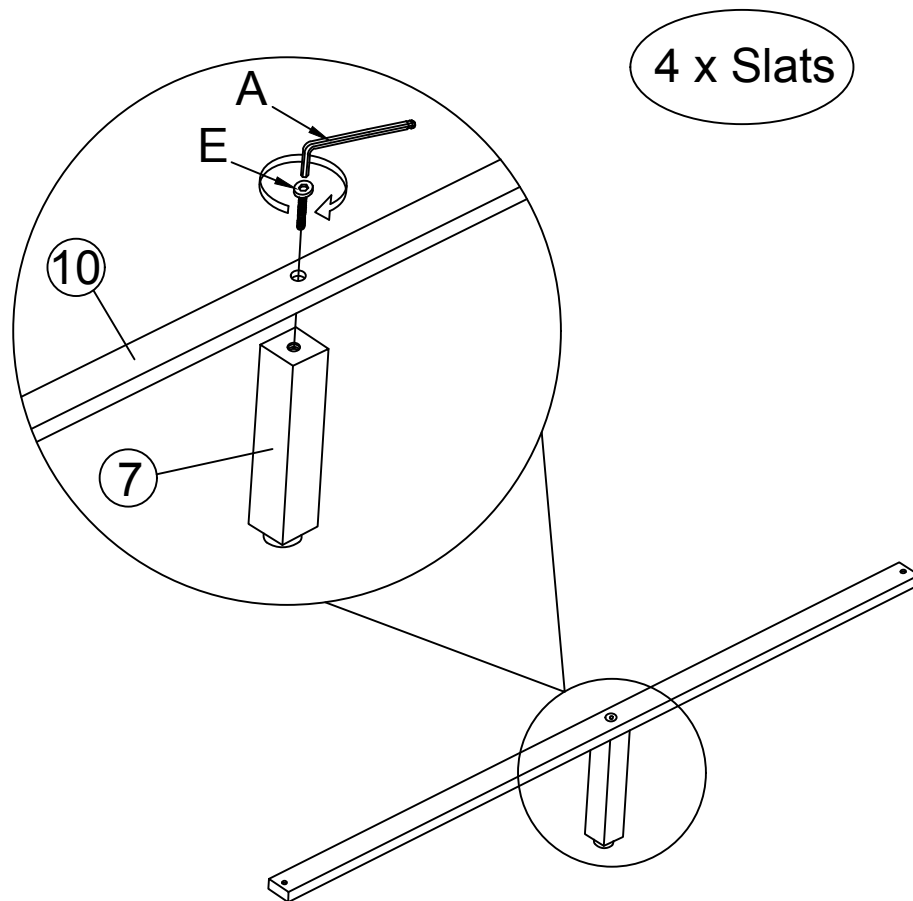

E - JCBC Bolt M6 x 35mm - 4pcs

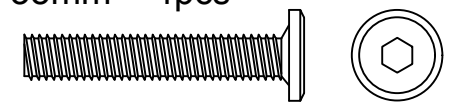

A - Allen Key M4 - 1pc



ASSEMBLY INSTRUCTION

QUEEN BED

STEP 3.

Attach and tighten the Side Rail Right (3) (2pcs) and Side Rail Left (4) (2pcs) to Side Rail Leg (9) (2pcs). Use JCBC Bolt (E), Spring Washer (H), Flat Washer (I), Side Rail Connect (C), Spring Washer (H), JCBC Bolt (D) and Allen Key M4 (A) to fix.

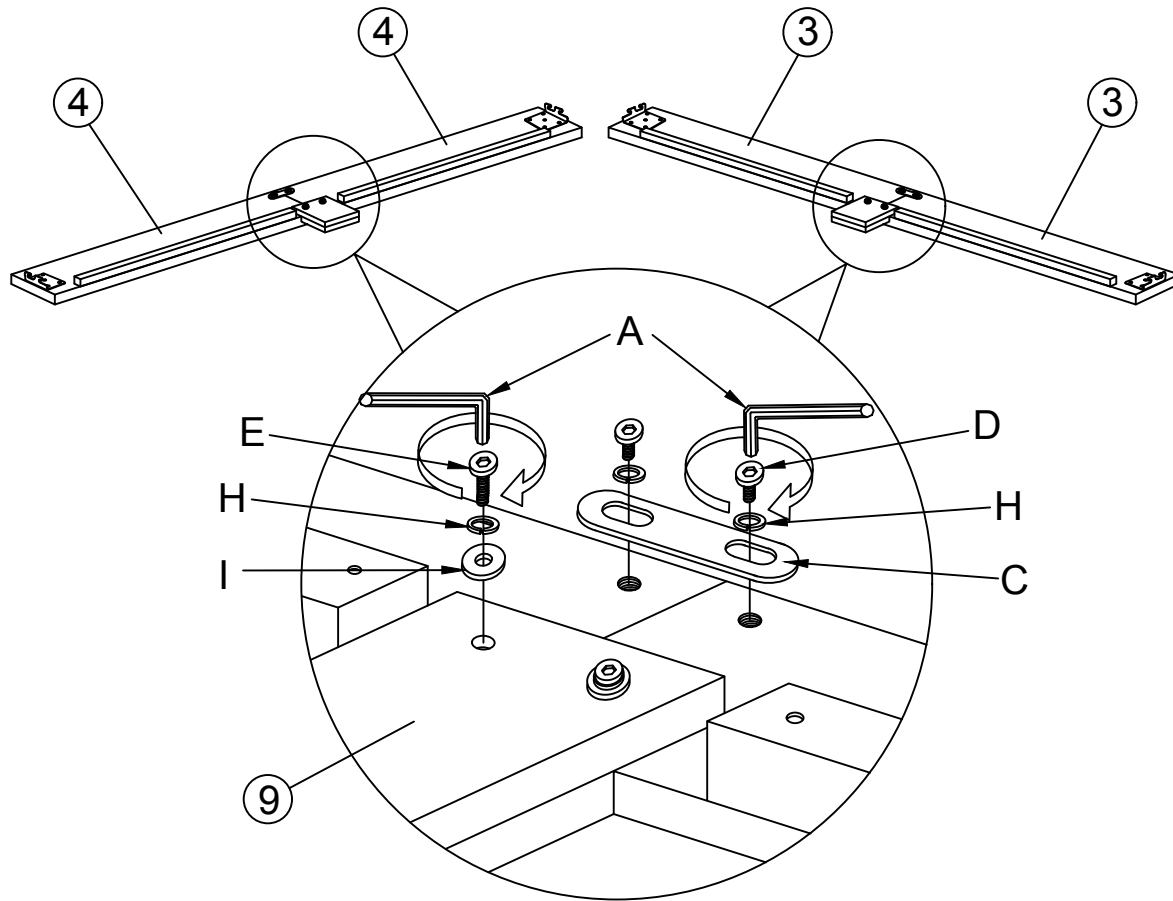

C - Side Rail Connect - 2pcs



I - Flat Washer M8 - 4pcs

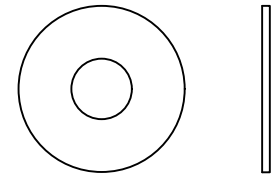

H - Spring Washer M6 - 8pcs

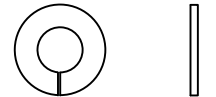

D - JCBC Bolt M6 x 15mm - 4pcs

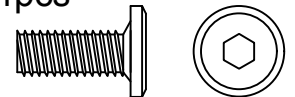

E - JCBC Bolt M6 x 35mm - 4pcs

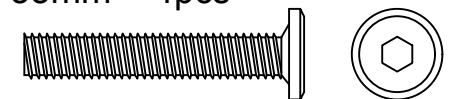

A - Allen Key M4 - 1pc

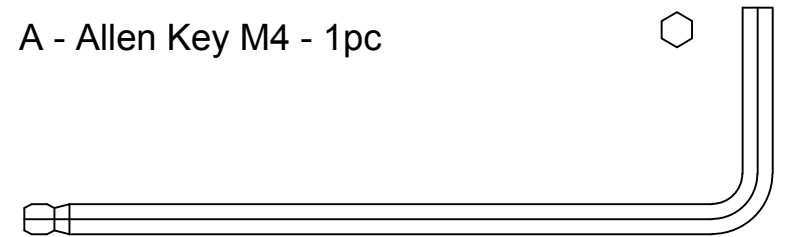

STEP 4.

Attached the Footboard Leg (8) (2pcs) to Footboard Panel (2).

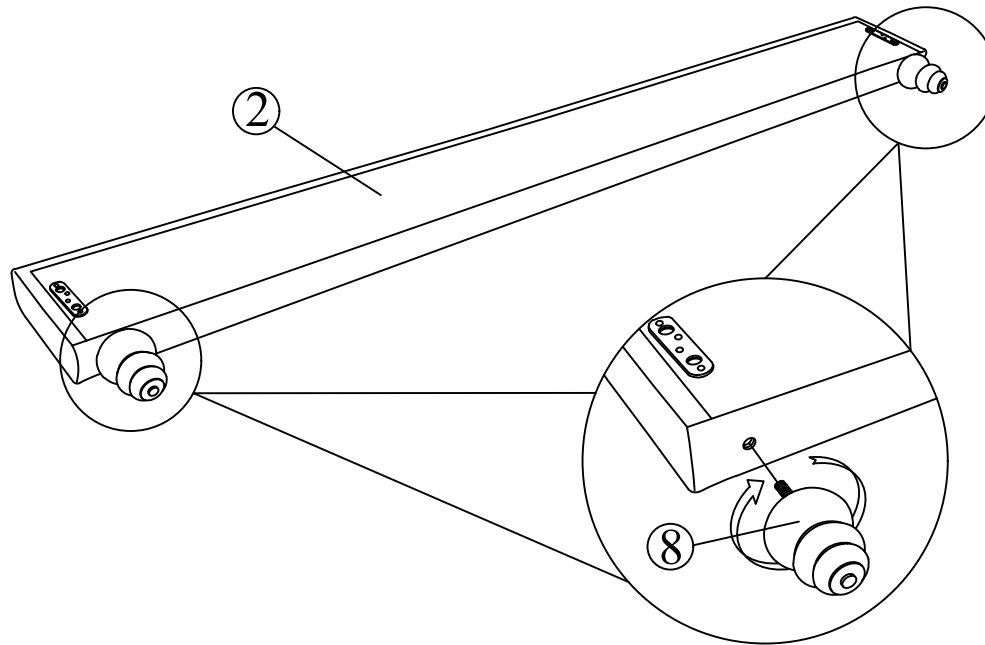

ASSEMBLY INSTRUCTION

QUEEN BED

STEP 5.

Attach the all Side Rail to bracket of Headboard Panel (1) and Footboard Panel (2).
Use JCBB Bolt (G) and Allen Key M5 (B) to fix.

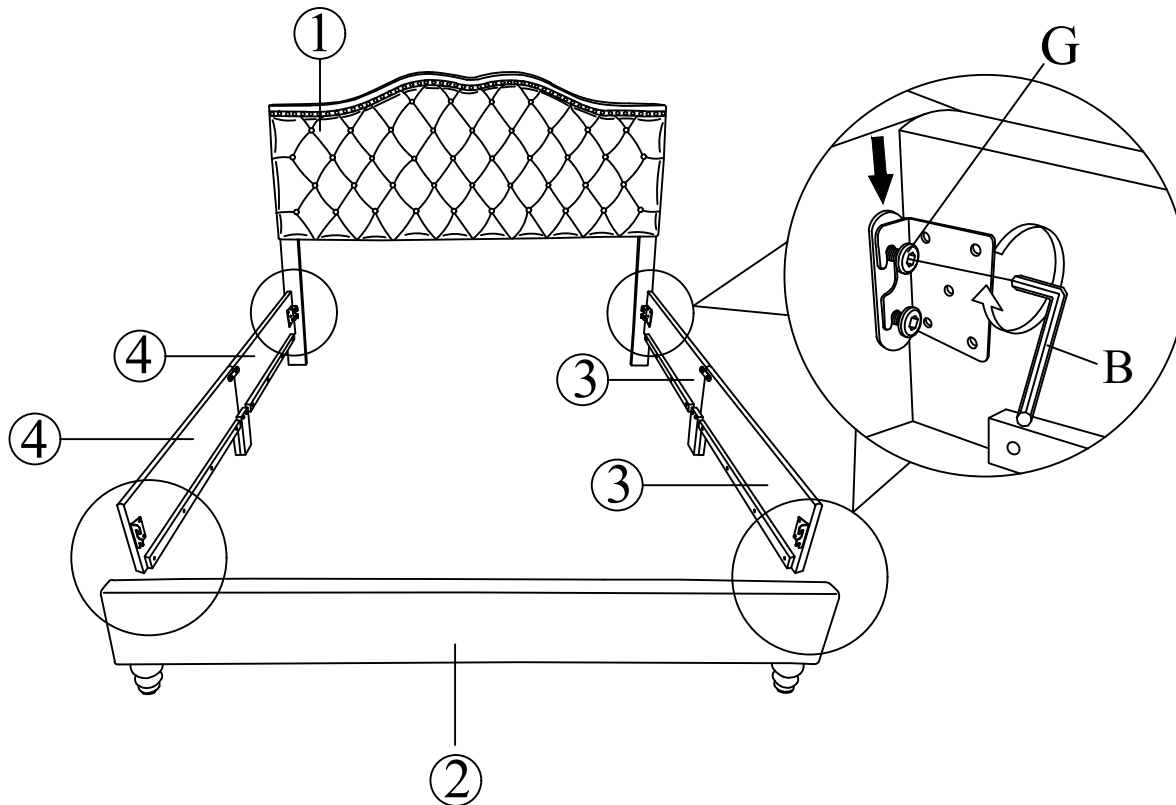

G - JCBB Bolt M8 x 16mm - 8pcs

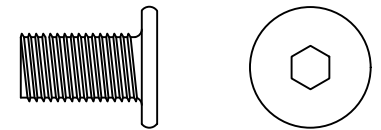

B - Allen Key M5 - 1pc

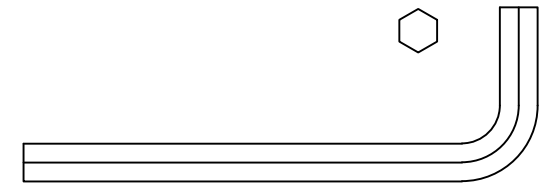

ASSEMBLY INSTRUCTION

QUEEN BED

STEP 6.

Attach and tighten the Left Wing (5) and Right Wing (6) to Headboard. Use JCBC Bolt (F), Spring Washer (H), Flat Washer (I) and Allen Key M4 (A) to fix.

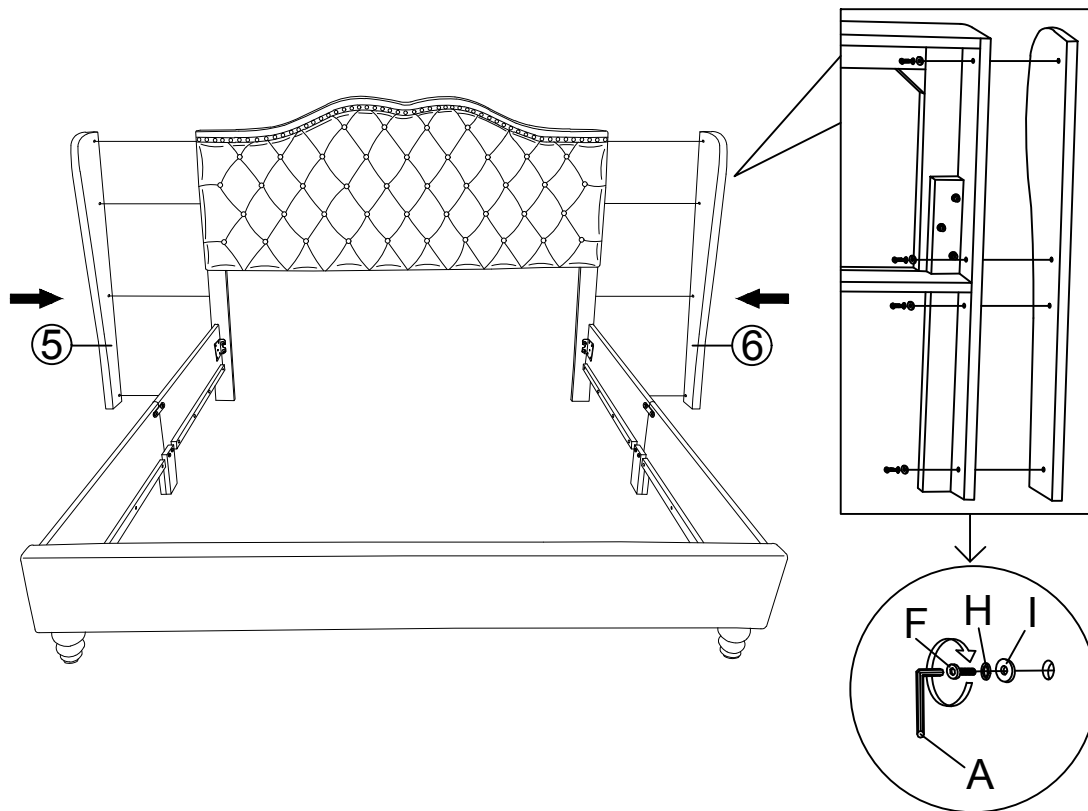

I - Flat Washer M8 - 8pcs

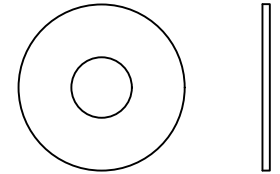

H - Spring Washer M6 - 8pcs

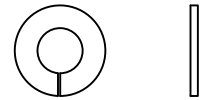

F - JCBC Bolt M6 x 40mm - 8pcs

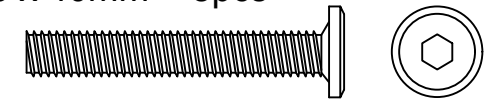

A - Allen Key M4 - 1pc

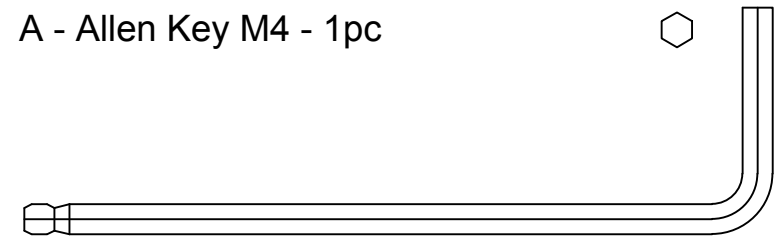

ASSEMBLY INSTRUCTION

QUEEN BED

STEP 7.

Attach and tighten the Slats (10) to Side Rail. Adjusting the leg adjuster to the floor. Use Screw M4 x 32mm (J) and screwdriver to fix.

