

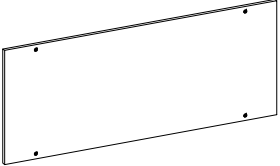

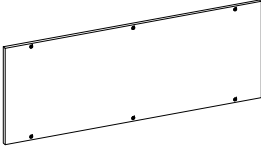

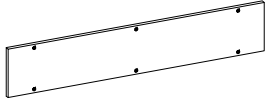

ASSEMBLY INSTRUCTION

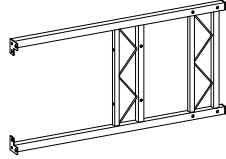
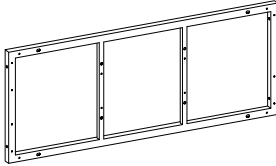
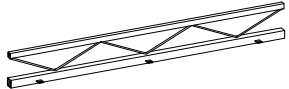

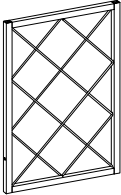





WINE RACK

1. Extra Screws of A/B/C/D/E are provided in case of any screws missing in the boxes.
2. Please take the time to identify and count all parts as well as the hardware to this product.

PART LIST

					
1 ×1PC	2 ×1PC	3 ×1PC	4 ×2PCS	5 ×1PC	6 ×2PCS
					
7 ×2PCS	8 ×2PCS	9 ×2PCS	10 ×1PC	11 ×1PC	12 ×4PCS

HARDWARE

								
M6×12mm	M6×15mm	M6×35mm	M6×40mm	M6×45mm	Caster with Lock	Caster	4mm	Wrench
A×20PCS	B×8PCS	C×4PCS	D×16PCS	E×8PCS	F×2PCS	G×2PCS	H×1PC	I×1PC

Before Assembly

① Classifying the screws base on the size.

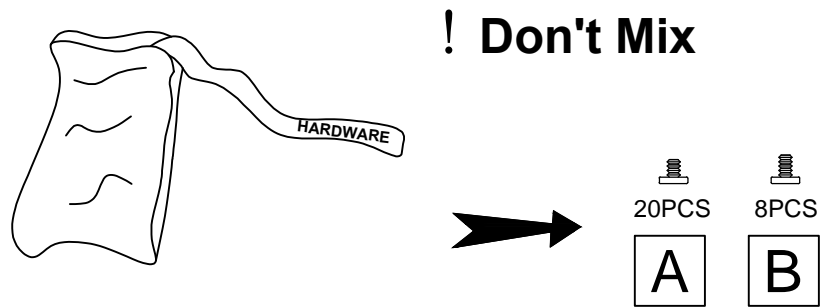

② Cut off the label and put it right here.

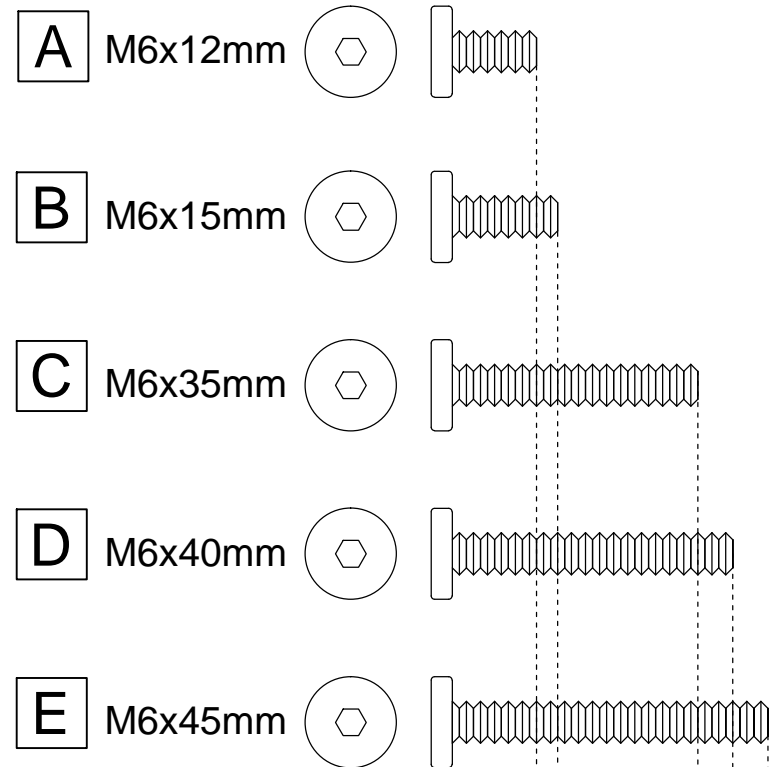
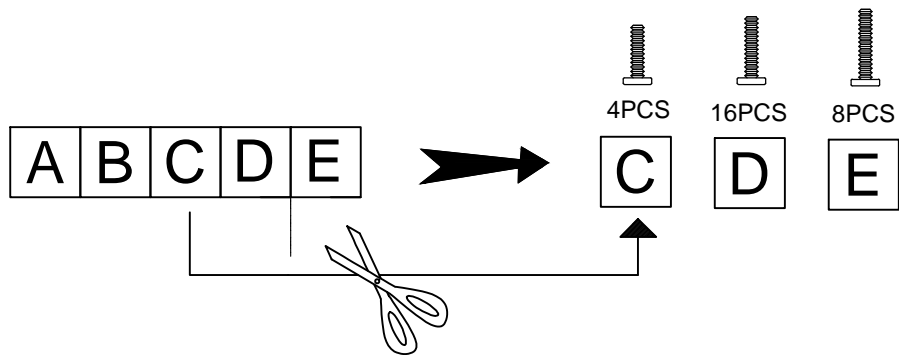

! If you fail to distinguish the screw size, you can measure them on the following size chart.

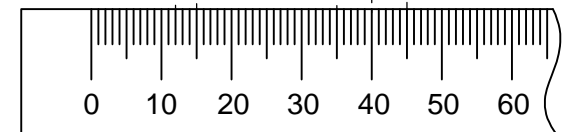

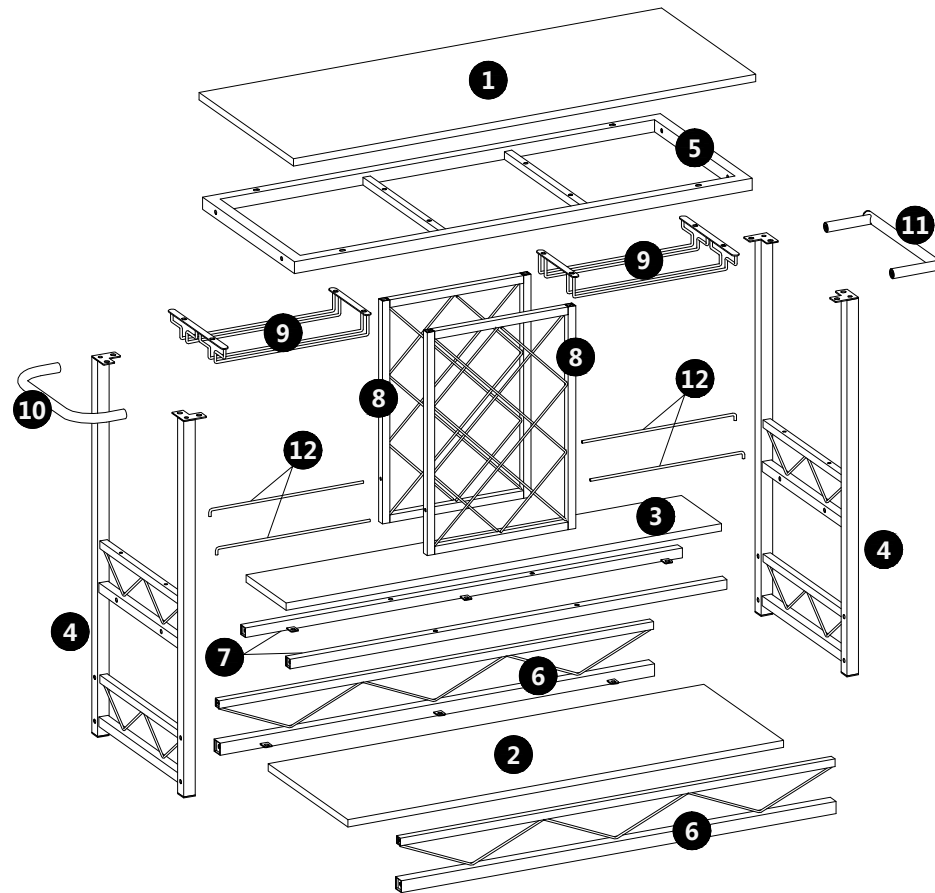

NOTED:

1. It is recommended that this item should be assembled by two adults.
2. Assemble this item on a soft surface, such as cardboard or carpet, to protect finish.

Please provide us with following information, so that it will be easier to resolve your problem smoothly.

1、 Order ID:

2、 Pictures of Your Items Damage or Parts Missing:

THANK YOU FOR PURCHASING OUR FURNTURE, IT IS AN HONOR TO BE IN YOUR HOME!

NOTED: Please do not tighten all bolts until the products is assembled completely.

Step 1:

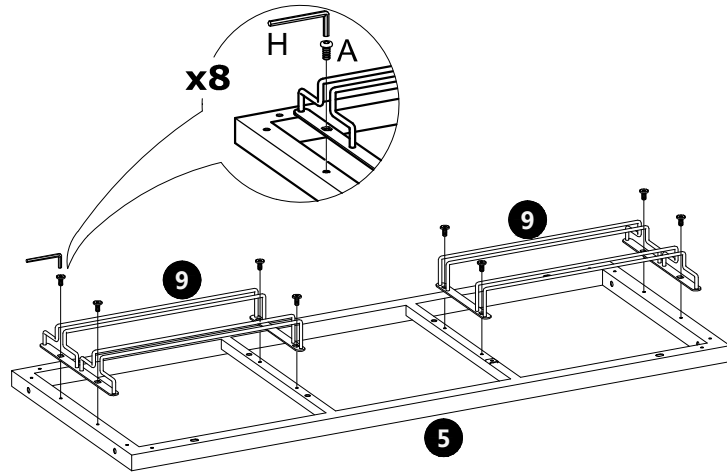

A×8PCS
M6×12mm

Step 2:

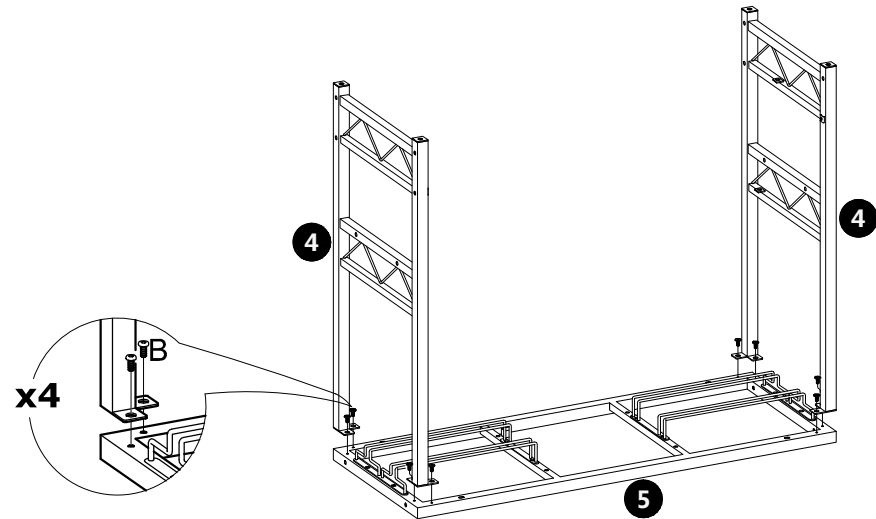

B×8PCS
M6×15mm

Step 3:

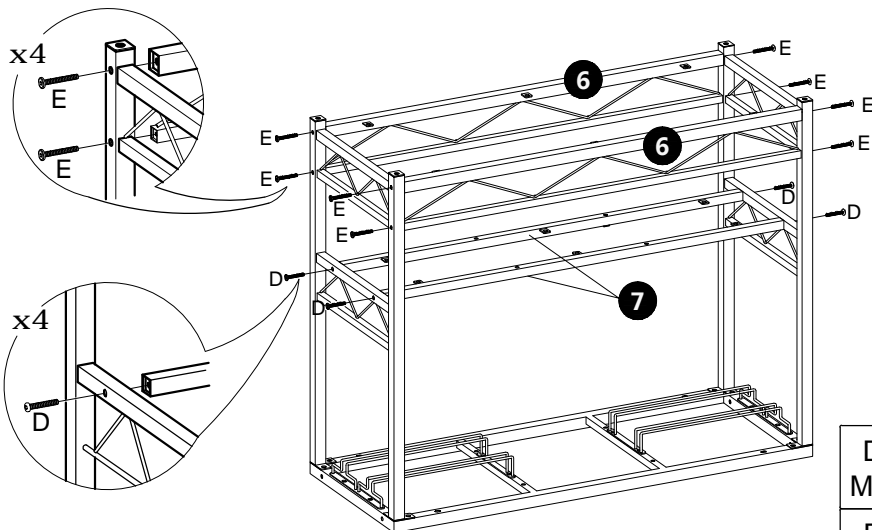

D×4PCS
M6×40mm
E×8PCS
M6×45mm

Step 4:

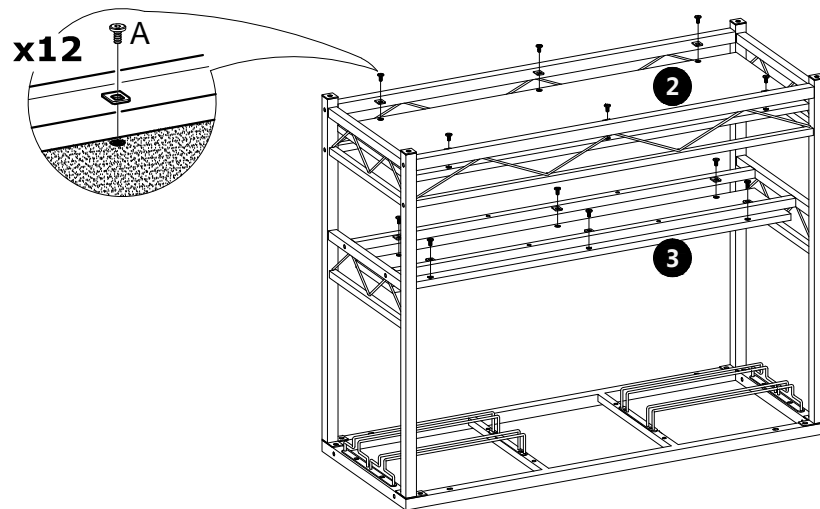

A×12PCS
M6×12mm

Step 5:

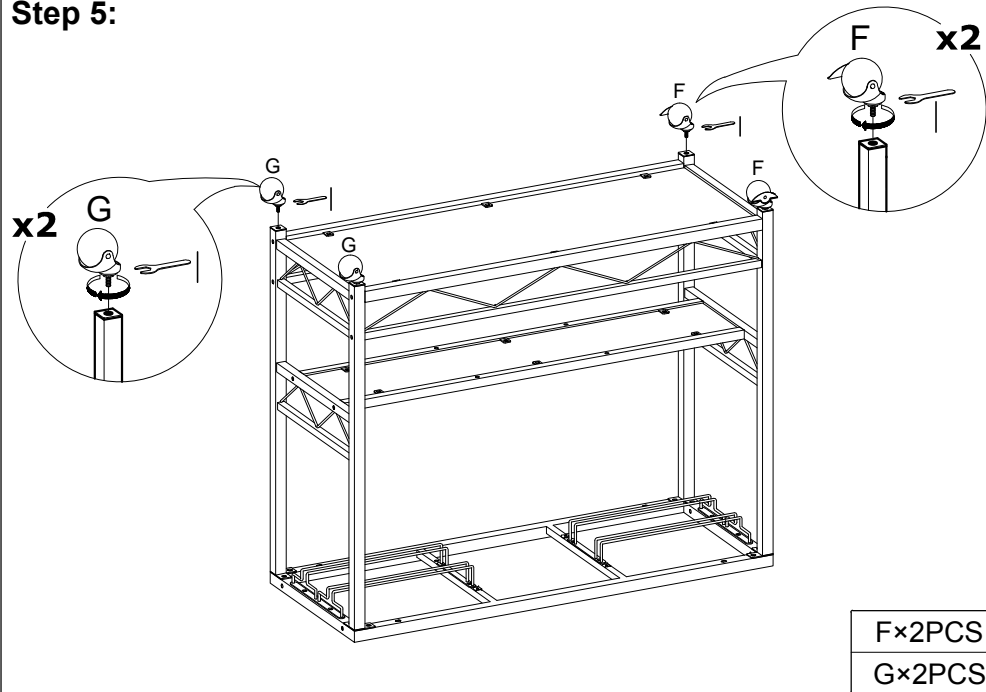

Step 6:

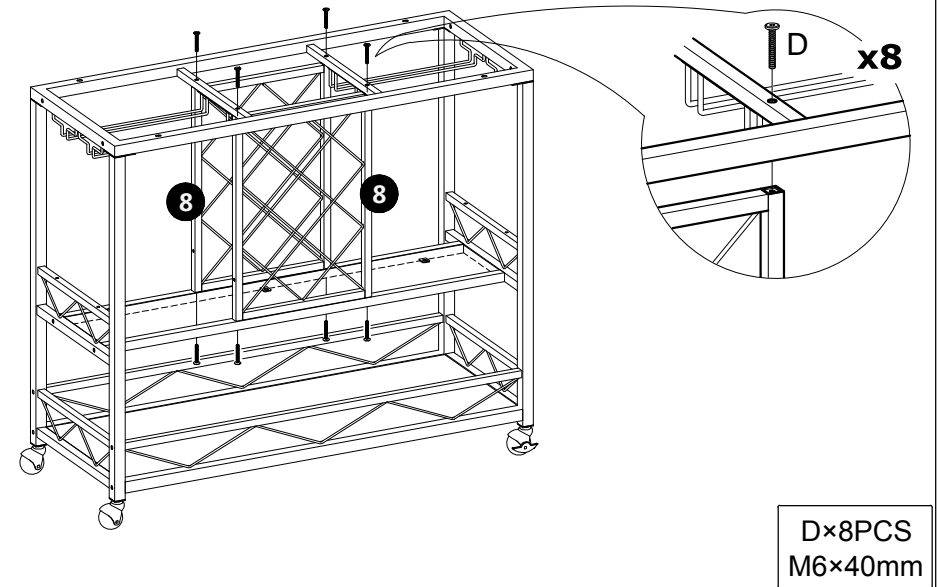

Step 7:

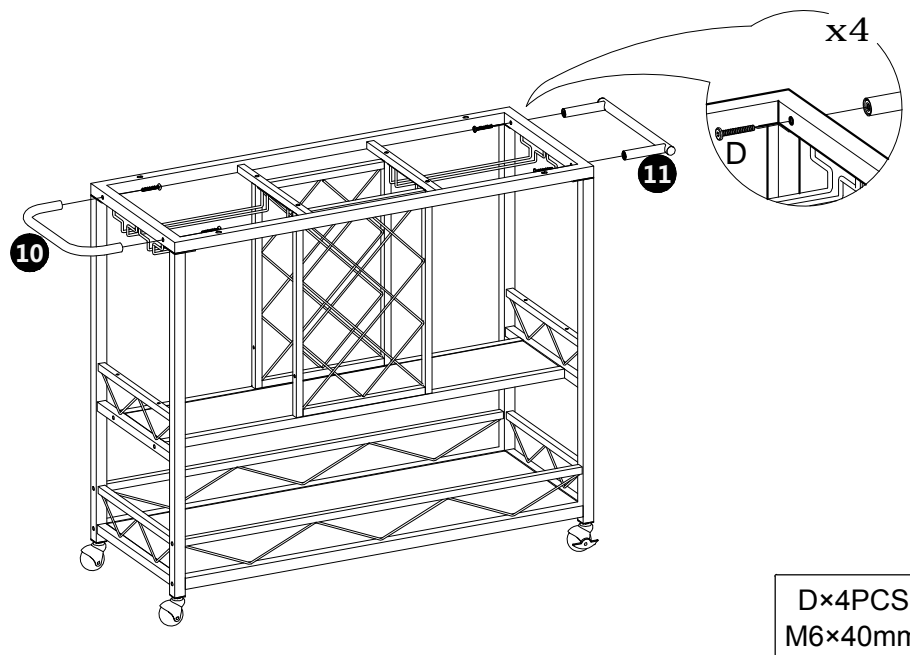

Step 8:

