

Assembly Instructions

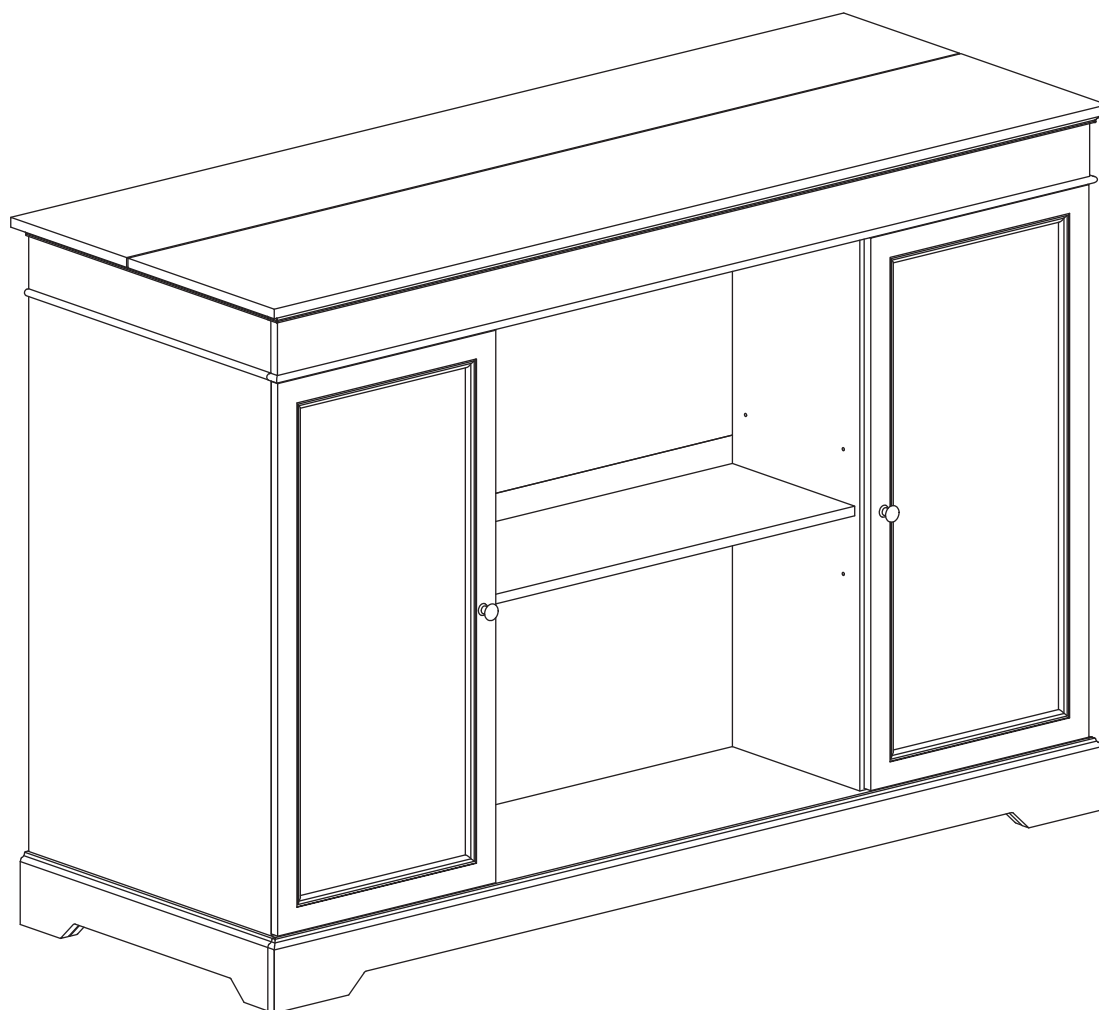







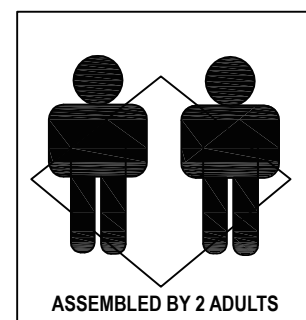

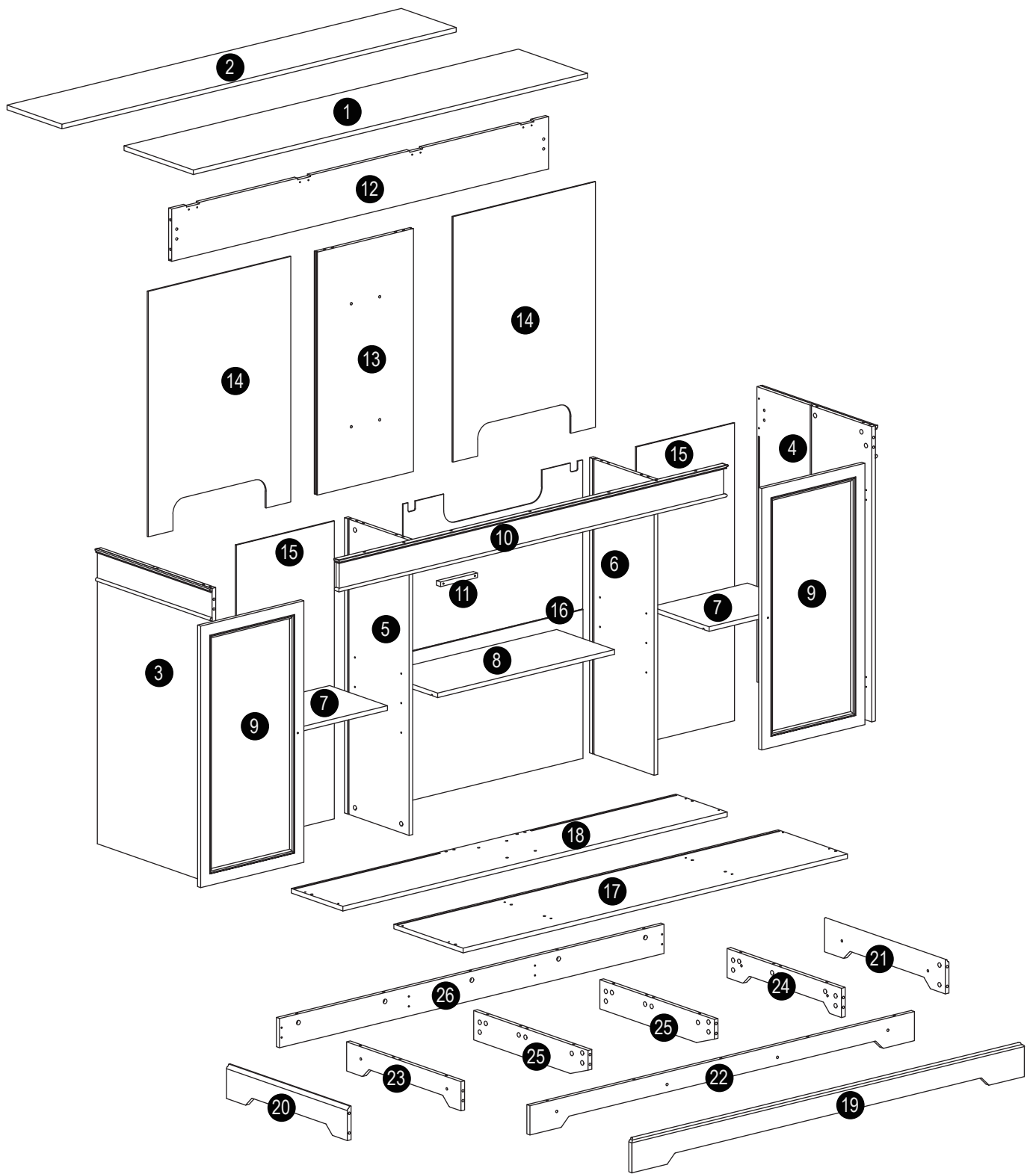

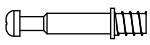





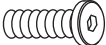
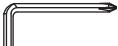



Note:

We come with the necessary tools for assembly but for faster assembly, a power drill is recommended

Please make sure all three cartons are received before beginning assembly.
Parts labeled with round numbers are included in the cabinet package (2 cartons).
Parts labeled with square numbers or letters are included in the electric lift package (1 carton).





A	x83+1	B	x83+1	C	x24+1	D	x54+1	E	x2+1	F	x2+1	G	x30+1	H	x12+1
															
Ø6×35mm	Ø15×12mm	Ø8×30mm	Ø3.5×14mm	Ø4×30mm	Ø4×35mm	M6×12mm	M6×25mm								
I	x1	J	x1	K	x2	L	x2+1	M	x4+1	N	x8	O	x2	P	x2
															
M4×64mm		Ø25×21mm	M4×18mm	M6	14×14×9mm	Ø8×40mm	155×20mm								
Q	x4	R	x4	S	x2	T	x4	U	x1	V	x12	W	x2		
															
51×27mm		50×30×30mm	85×60mm	60×20mm	Ø5×13mm										

1

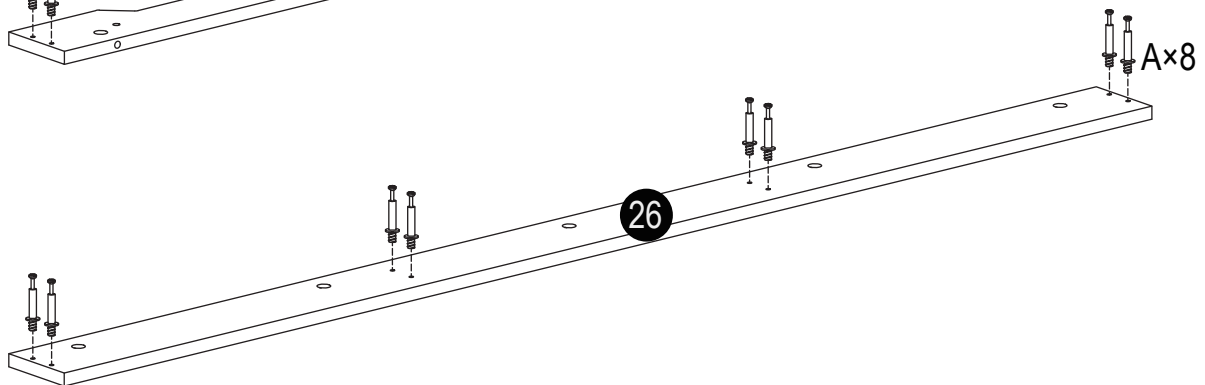
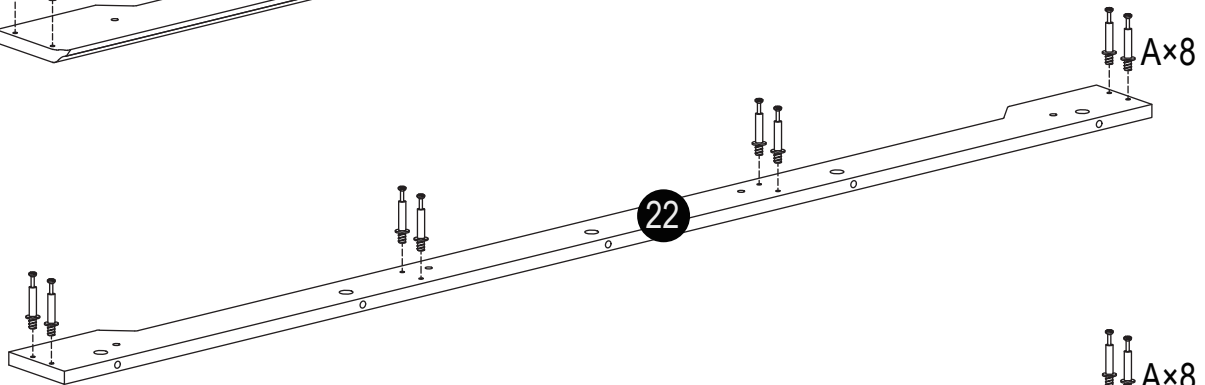
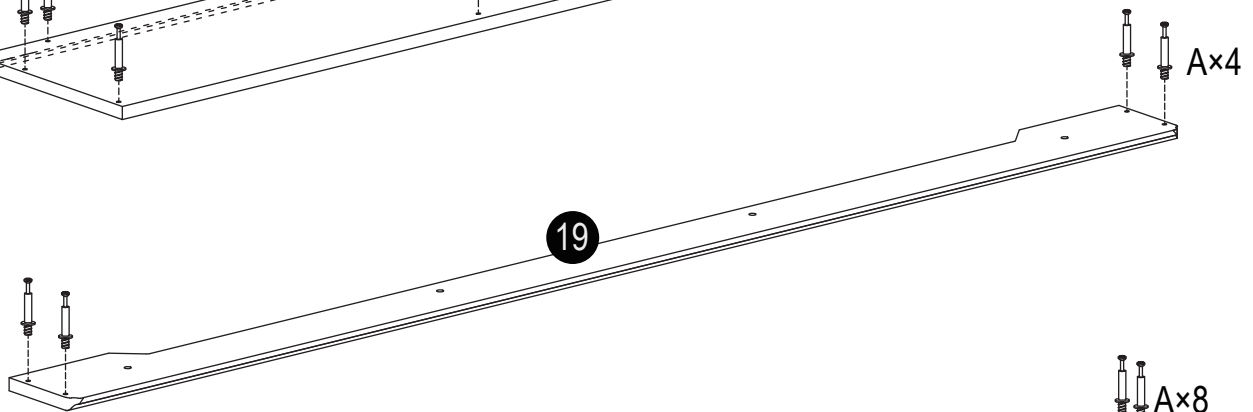
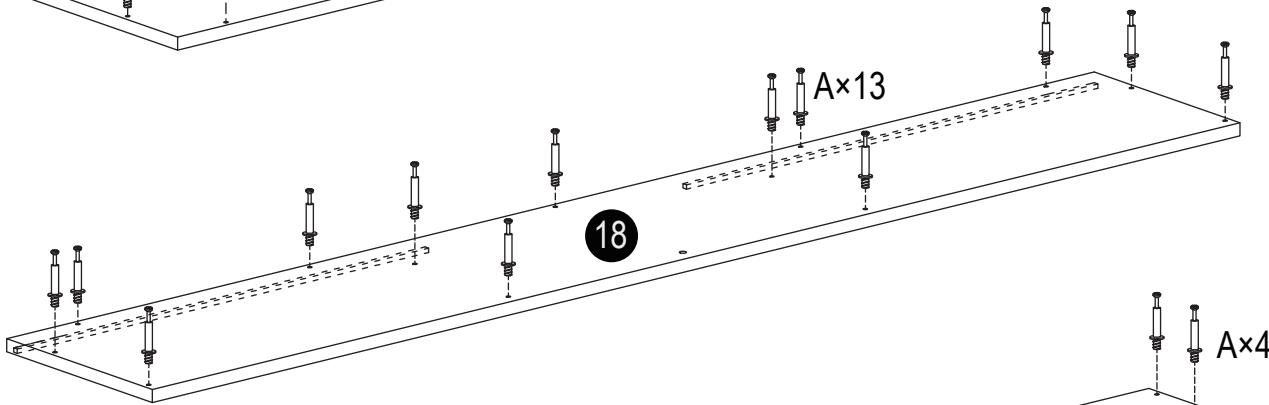
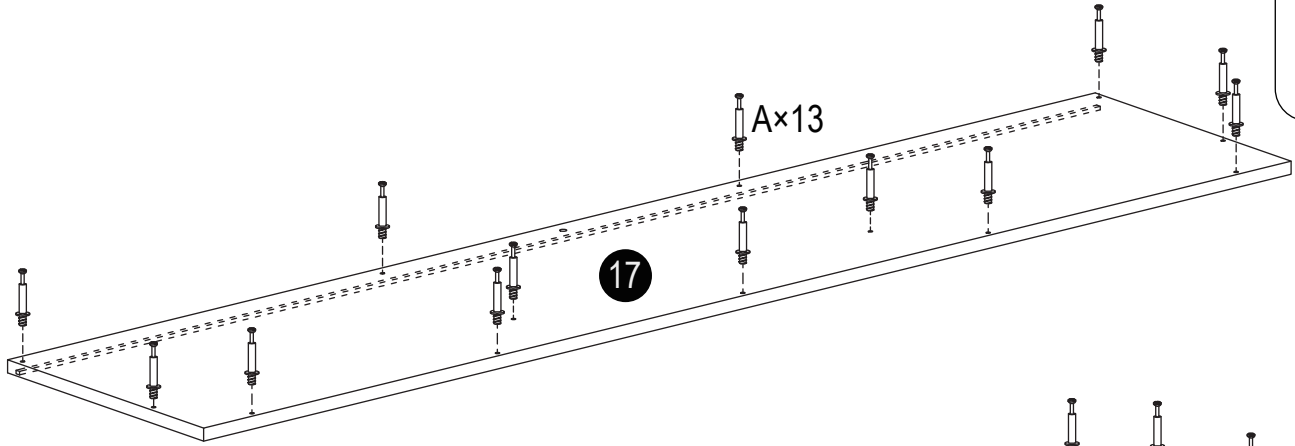
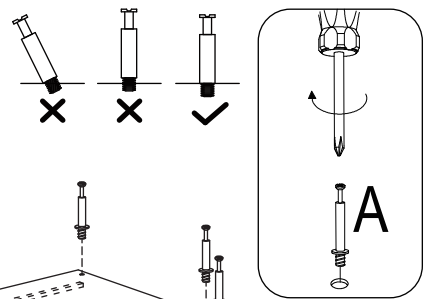

As shown, connect hardware A to parts #17, #18, #19, #22, and #26.

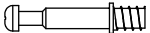
A	x46
	
Ø6x35mm	

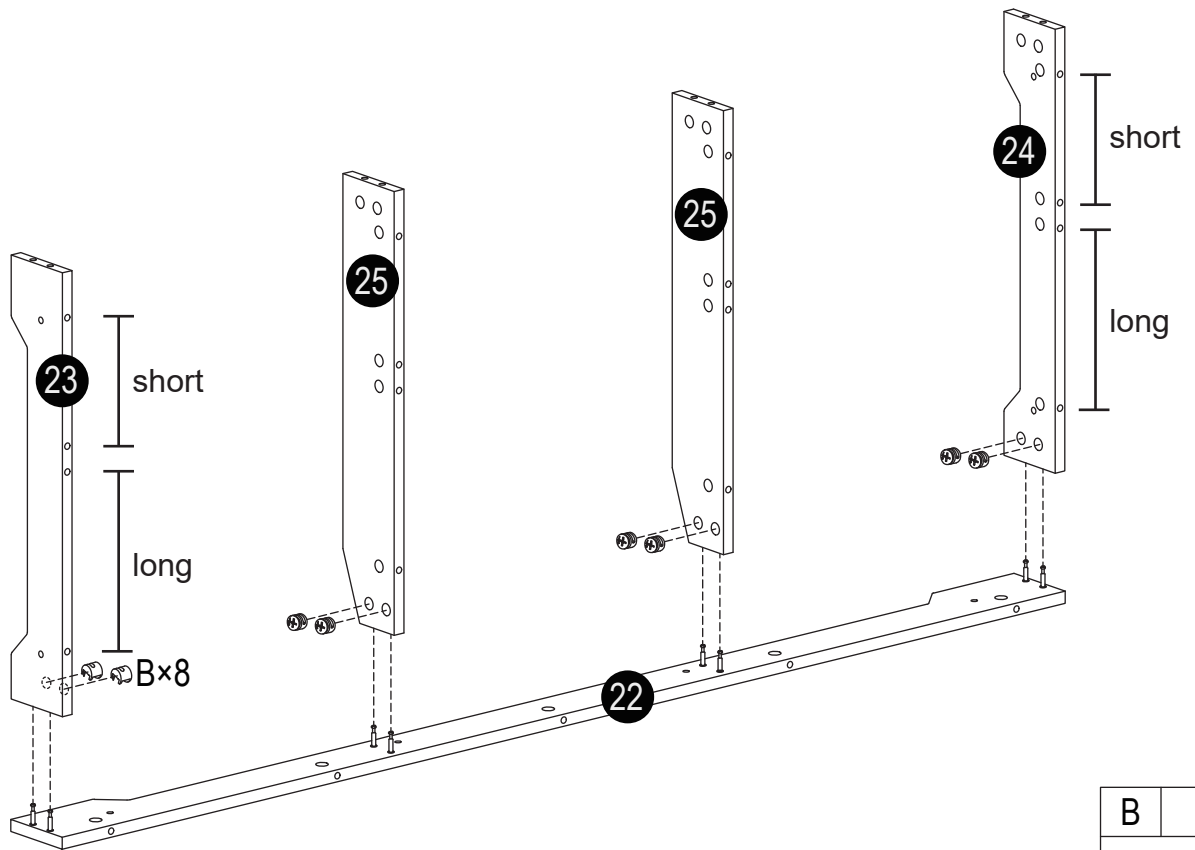
2

As shown, use hardware A and B to attach parts #25 (×2), #23, and #24 to part #22, then tighten all screws.

B	×8
Ø15×12mm	

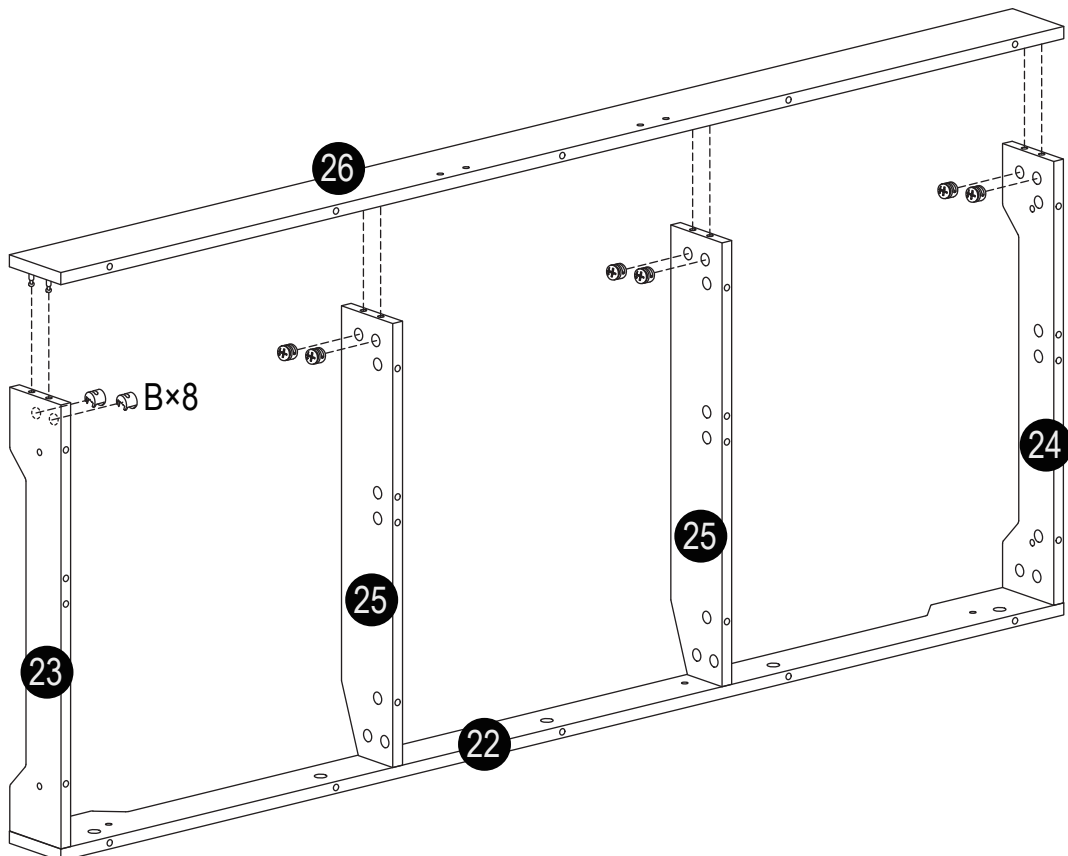
3

As shown, use hardware A and B to connect the assembled frame to part #26, then tighten all hardware B.

B	×8
Ø15×12mm	

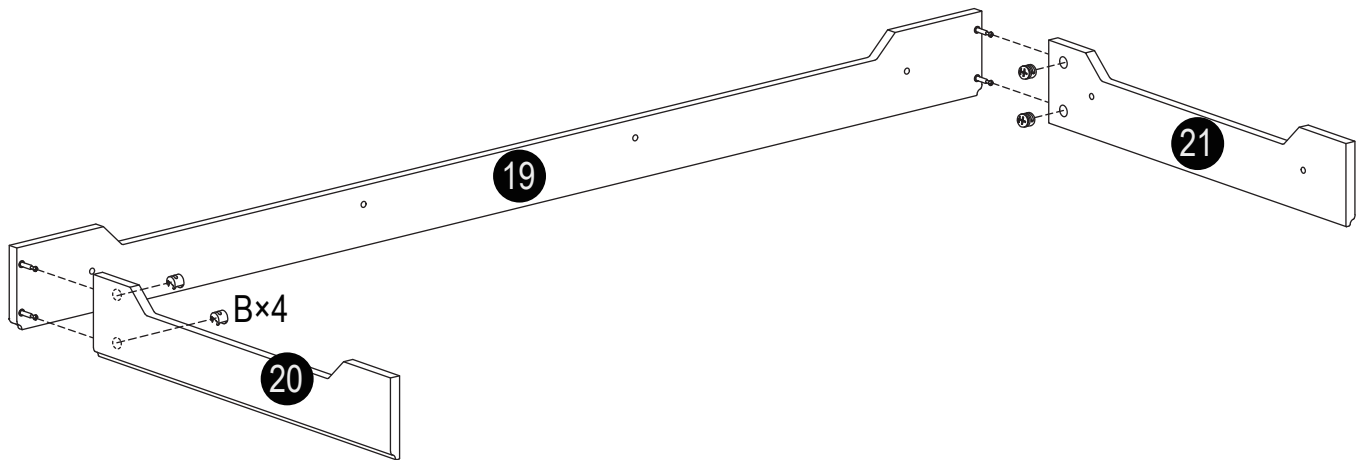
4

B	x4
Ø15x12mm	

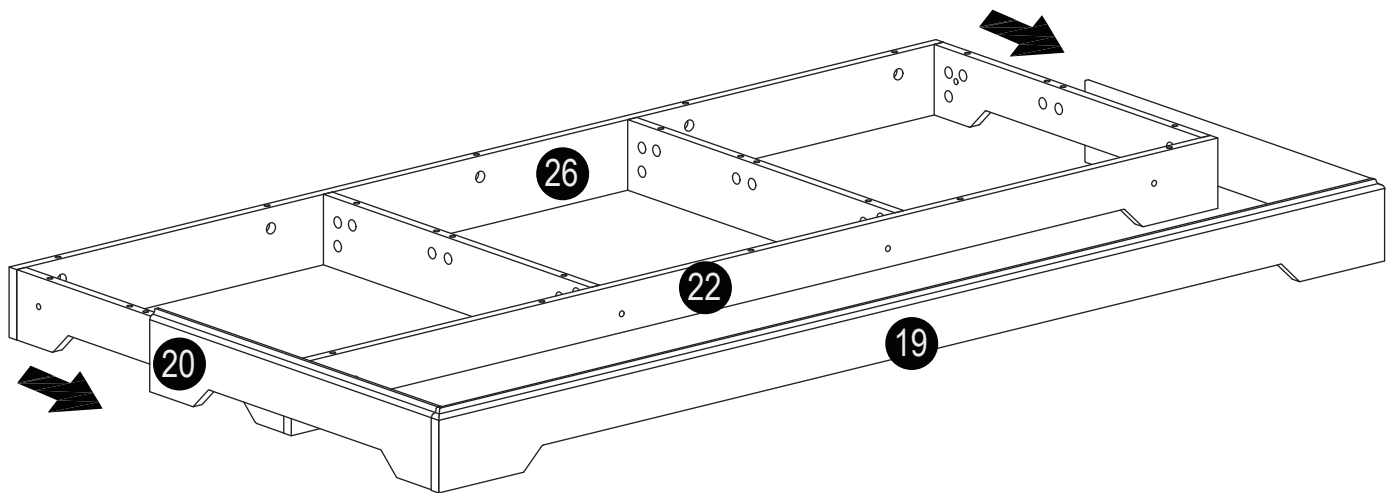

As shown, use hardware A and B to connect parts #20 and #21 to part #19, then tighten all hardware B.

5

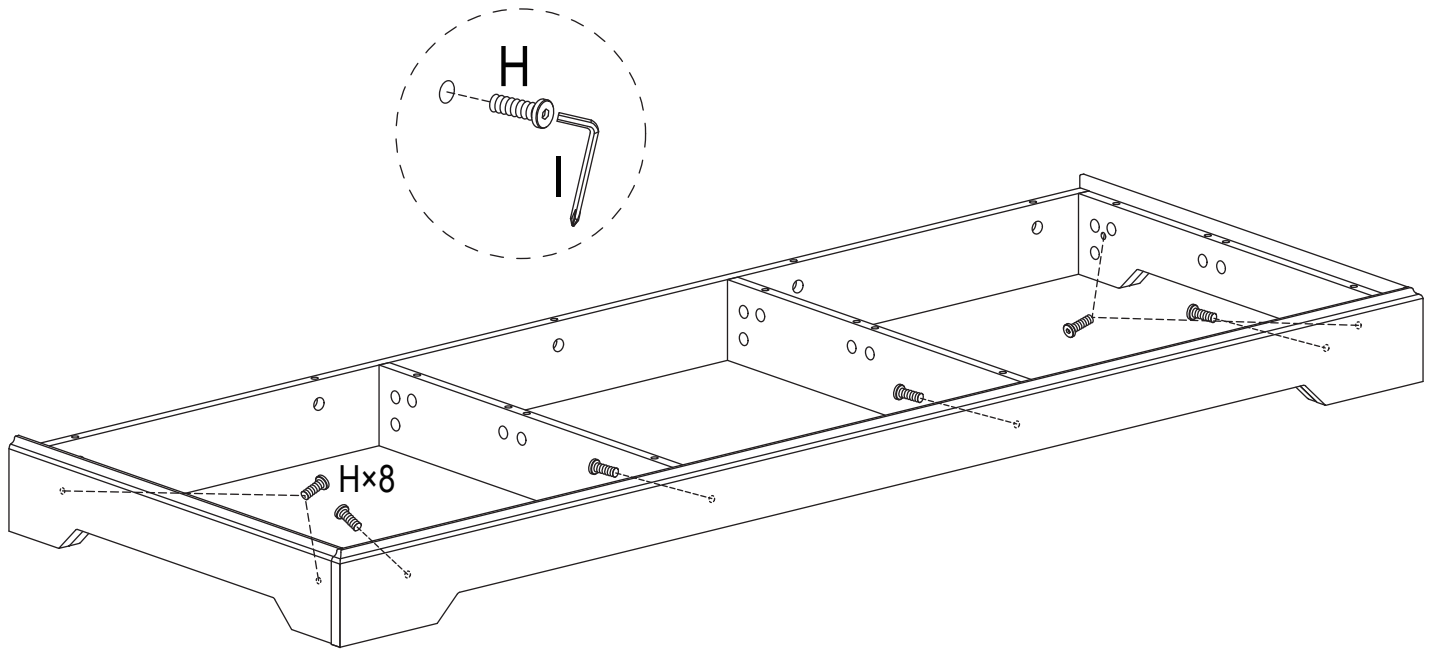
As shown, place the assembled parts from Step 3 and Step 4 together and align them properly.

6

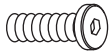
As shown, use tool I to tighten hardware H x 8, making sure the two sections are firmly connected.

H	x8	I	x1
			
M6x25mm		M4x64mm	

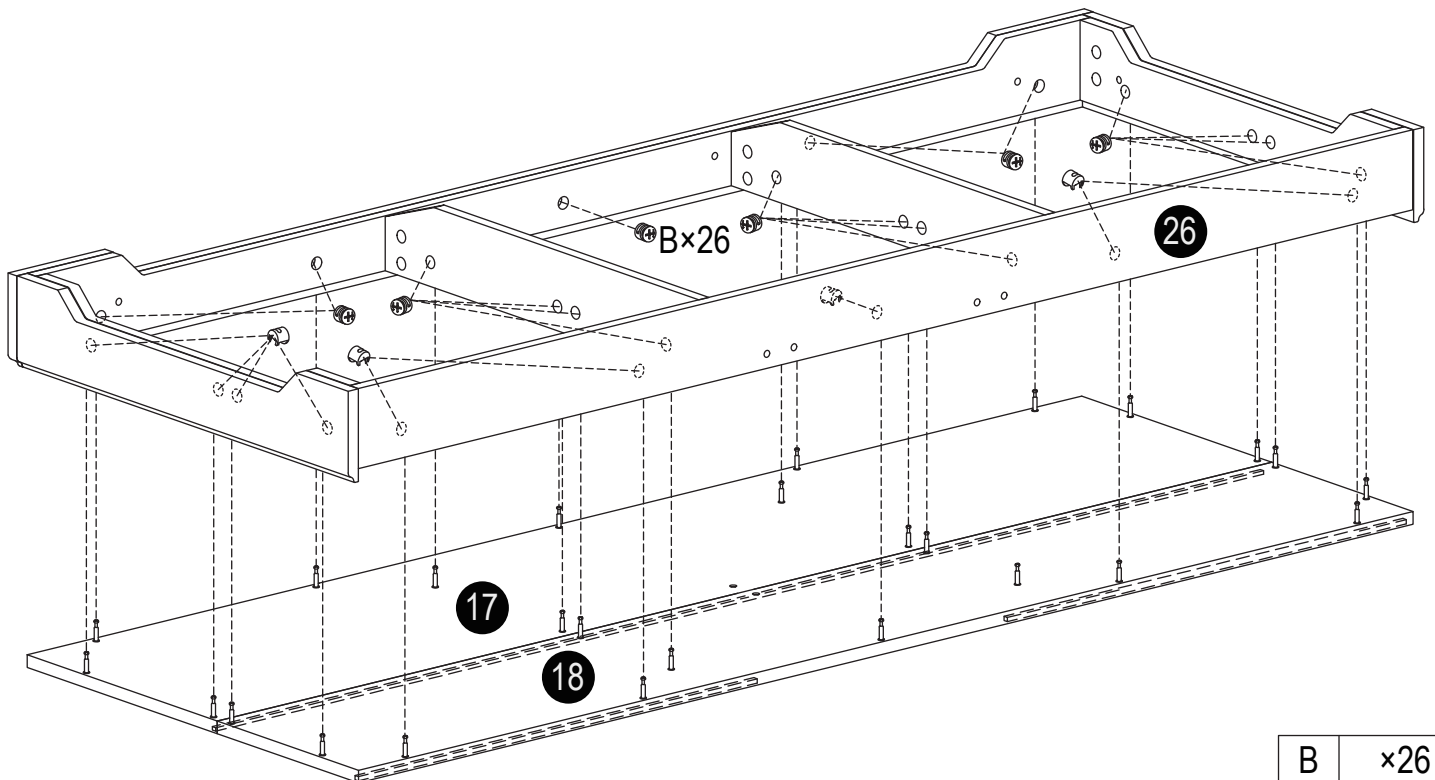
7



As shown, install hardware A on parts #17 and #18, then use hardware A and B to connect the assembled unit from the previous step to parts #17 and #18.

B	x26
	
Ø15x12mm	

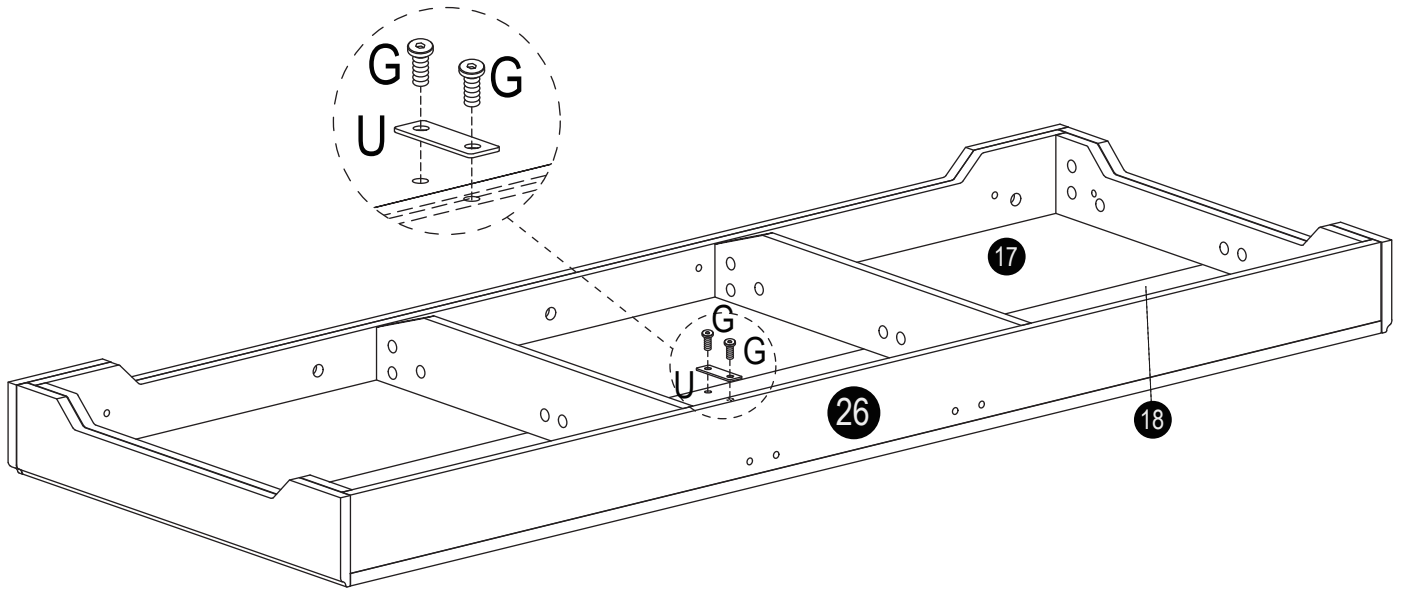
8



As shown, use hardware G $\times 2$ to secure the metal plate U, tightening it to parts #17 and #18.

G	$\times 2$	U	$\times 1$
			
M6 \times 12mm		60 \times 20mm	

9

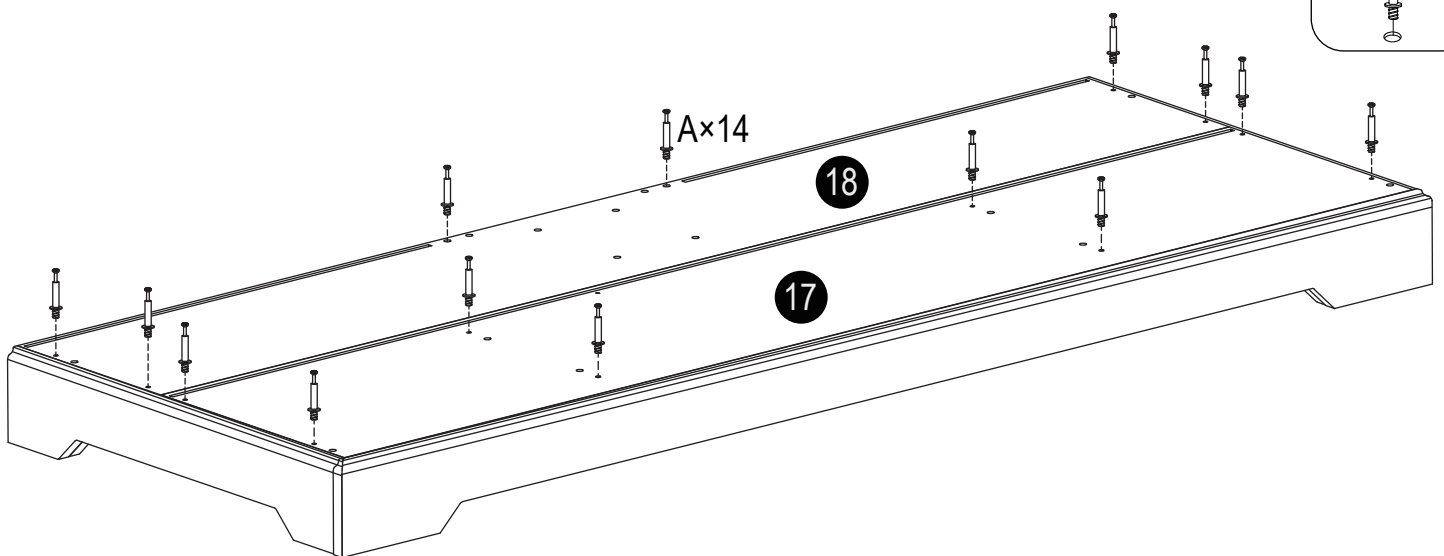
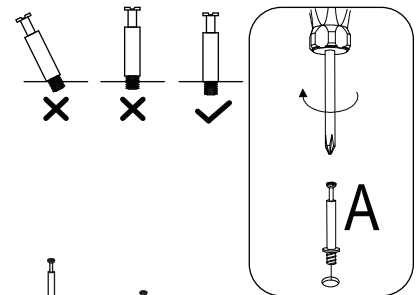

Turn over the assembled unit, then attach hardware A $\times 14$ to parts #17 and #18 as shown.

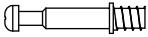
A	$\times 14$
	
$\text{\O}6 \times 35\text{mm}$	

10

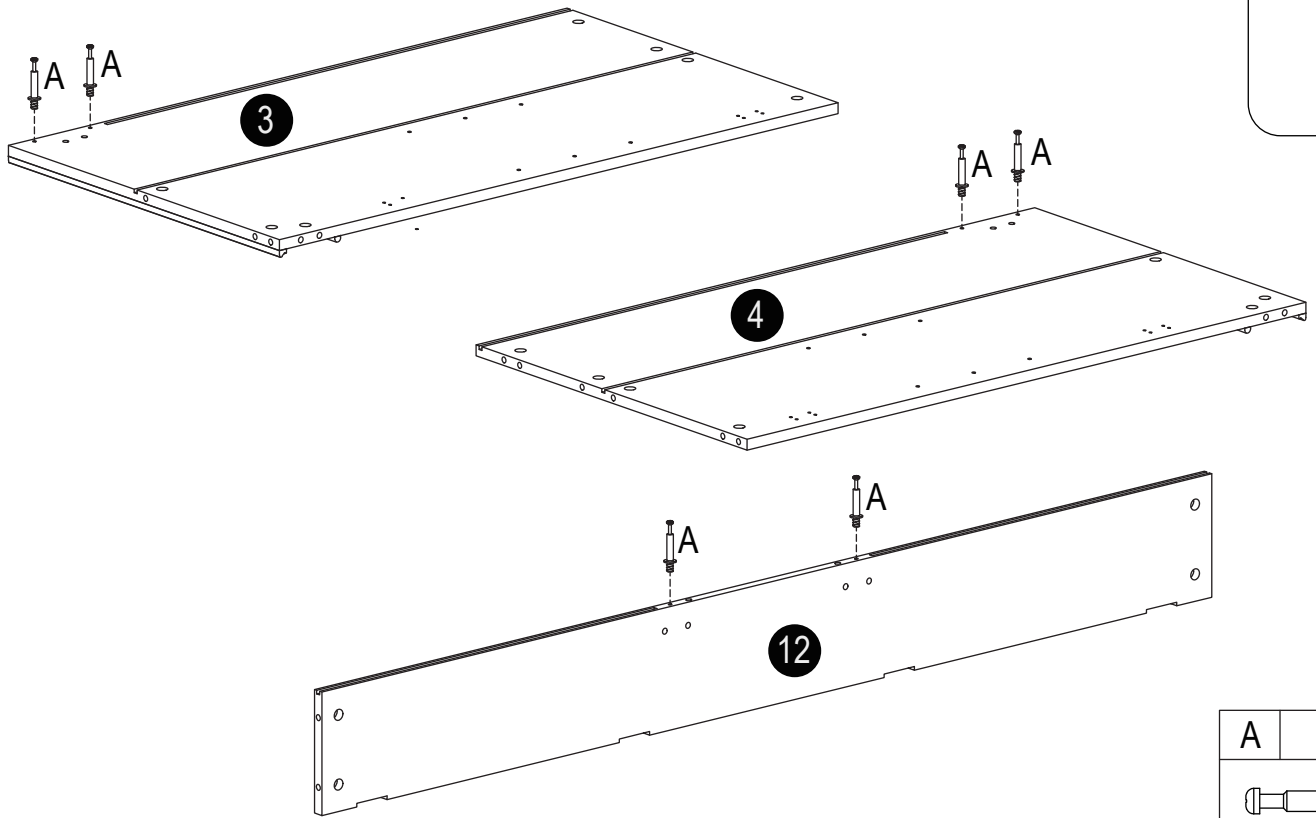

As shown, attach hardware A x6 to parts #3, #4, and #12.

11

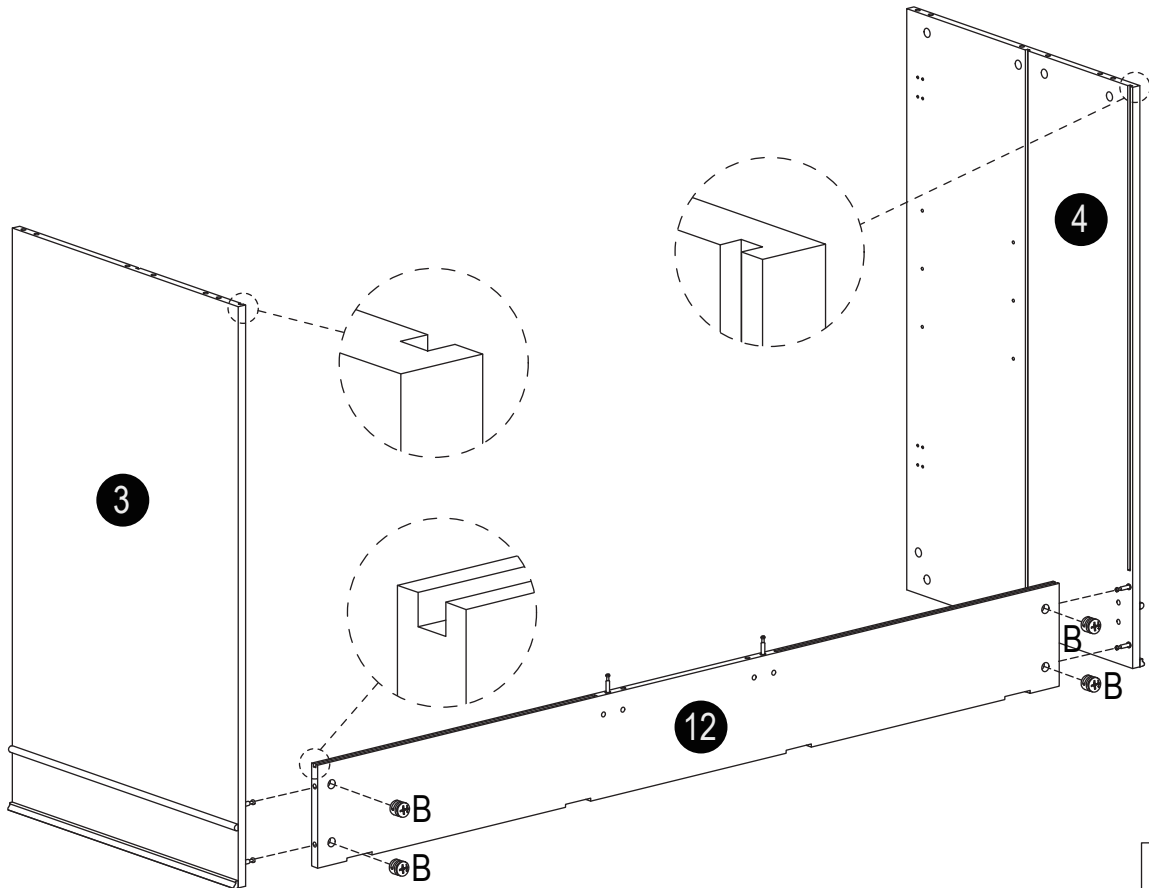

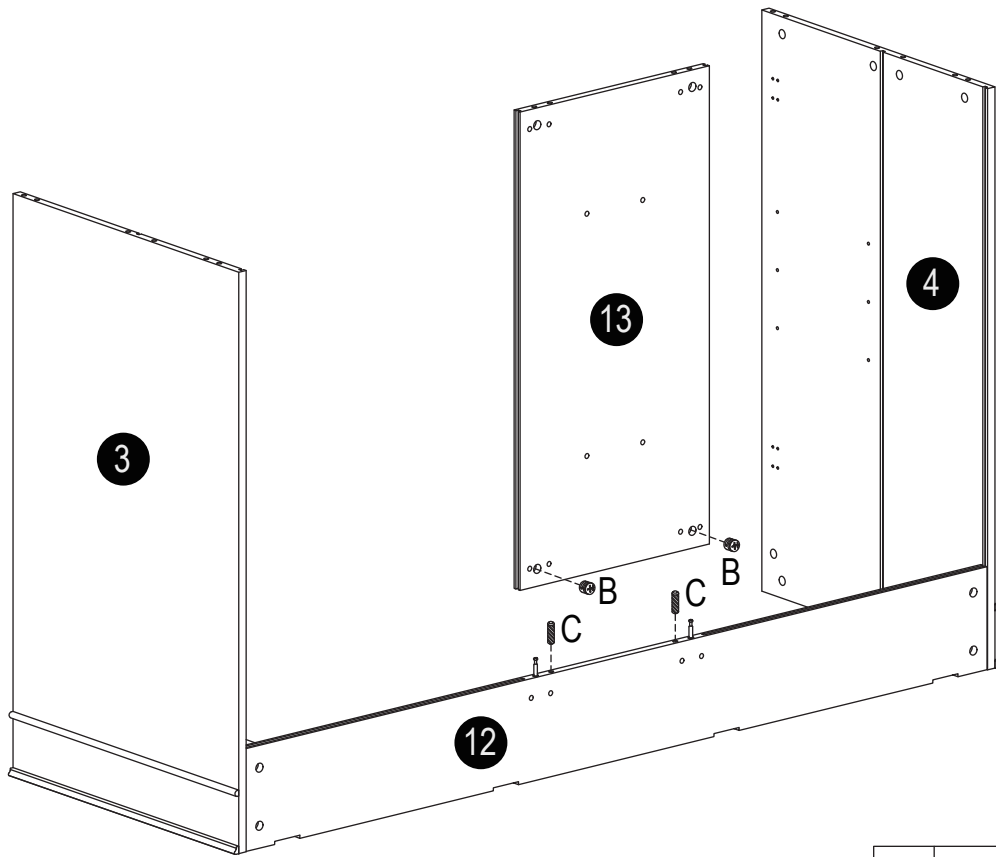

As shown, use hardware A and B to connect parts #3 and #4 to part #12.

12





As shown, insert wooden dowels C ×2 into part #12, then use hardware A and B to connect part #13 to part #12.

B	×2	C	×2
			
Ø15×12mm		Ø8×30mm	

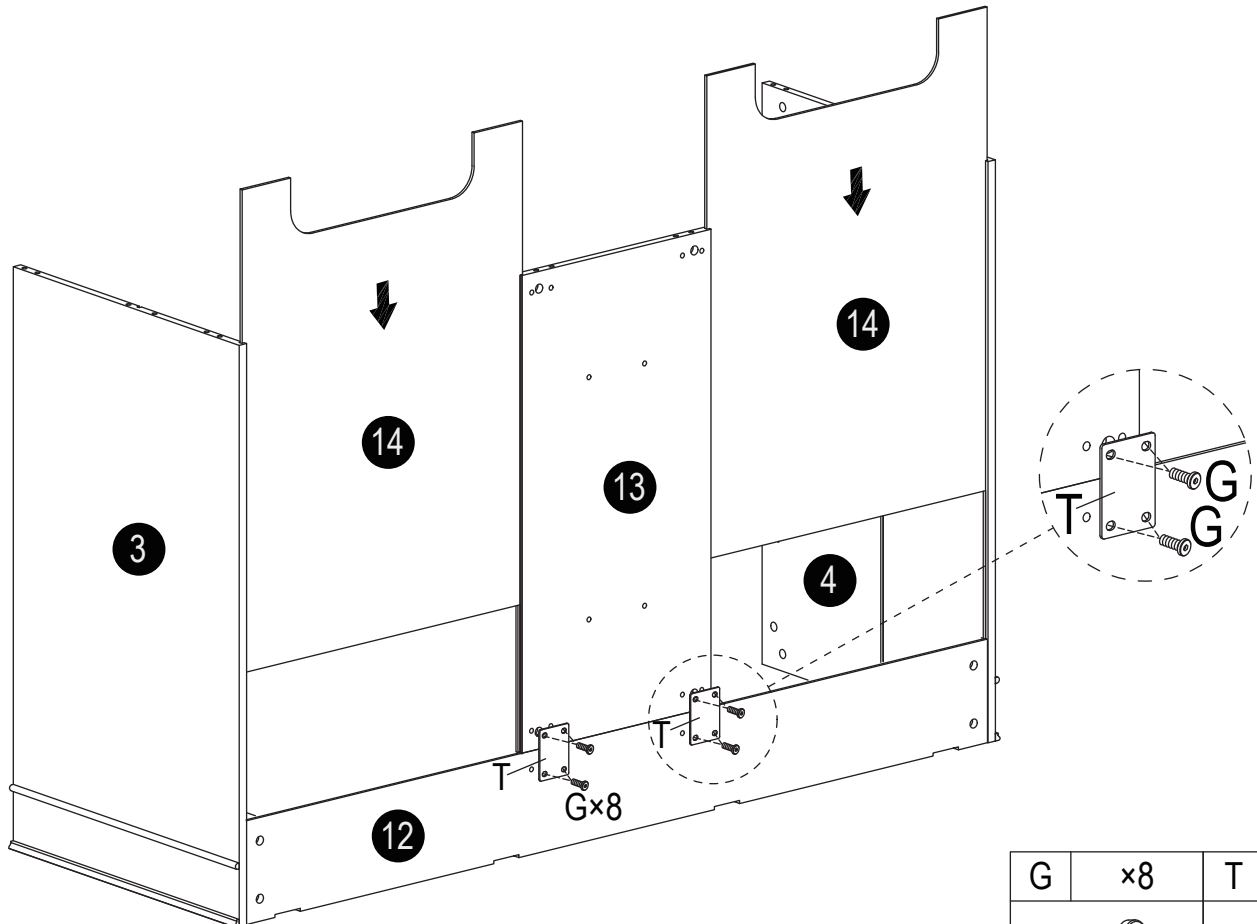
13





As shown, use hardware G ×8 to secure metal plates T ×2 to parts #12 and #13, then insert back panels #14 ×2 into the indicated positions.

G	×8	T	×2
			
M6×12mm		85×60mm	

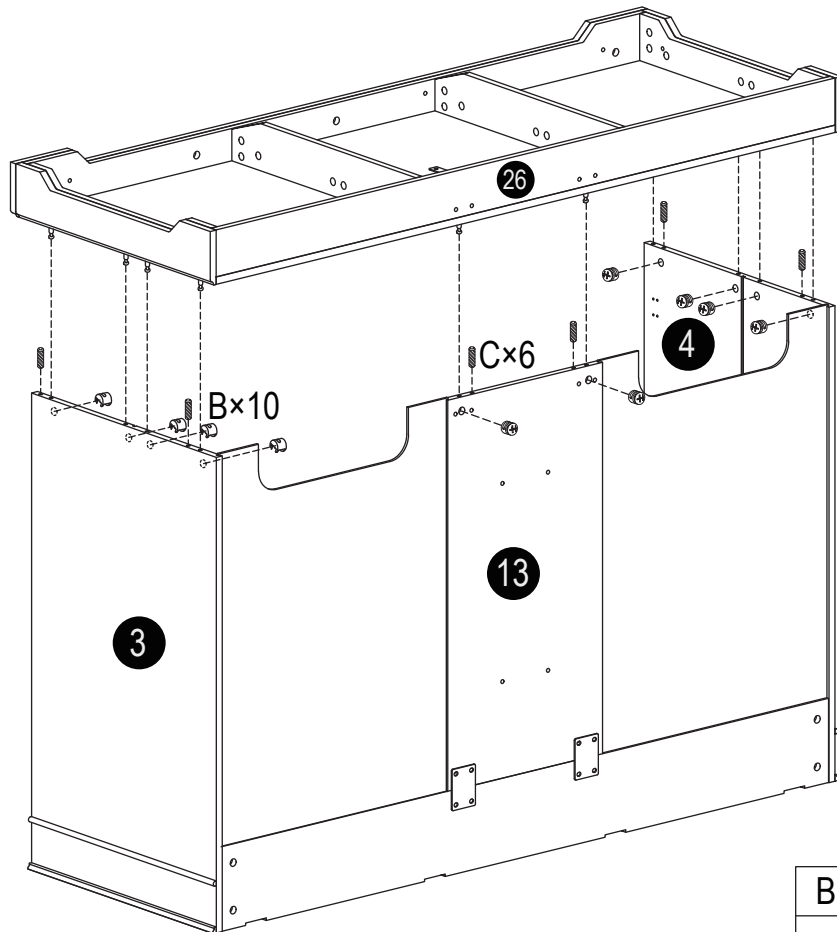
14





As shown, insert wooden dowels C × 6 into parts #3, #4, and #13. Then connect the assembled unit from Step 9 to the current structure using hardware A and B.

B	×10	C	×6
			
Ø15×12mm		Ø8×30mm	

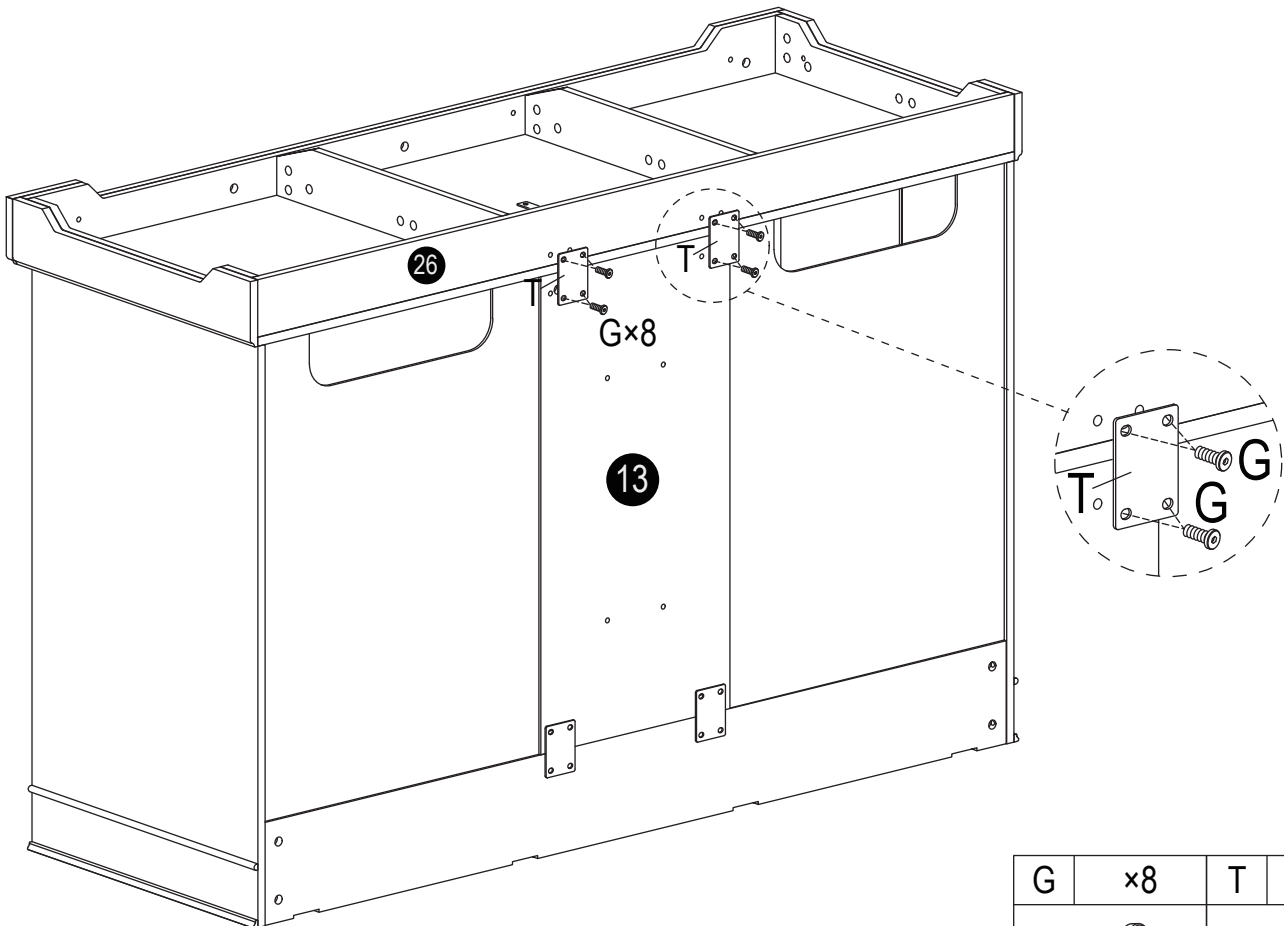
15





As shown, use hardware G × 8 to secure metal plates T × 2 to parts #13 and #26. This step helps make the cabinet more stable.

G	×8	T	×2
			
M6×12mm		85×60mm	

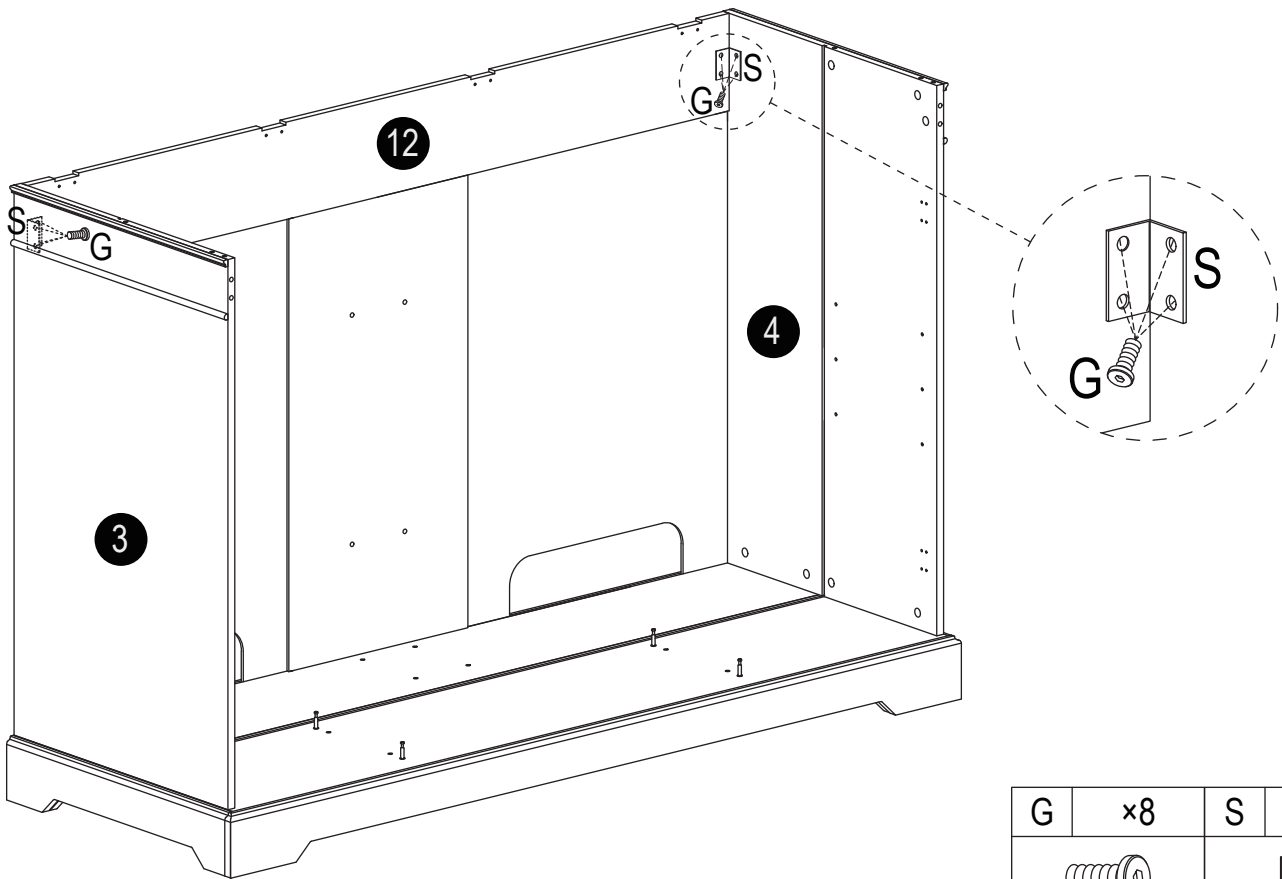
16



Turn the cabinet over, then use hardware G ×8 to secure metal plates S ×2 to parts #12, #3, and #4.

G	×8	S	×2
			
M6×12mm		50×30×30mm	

17

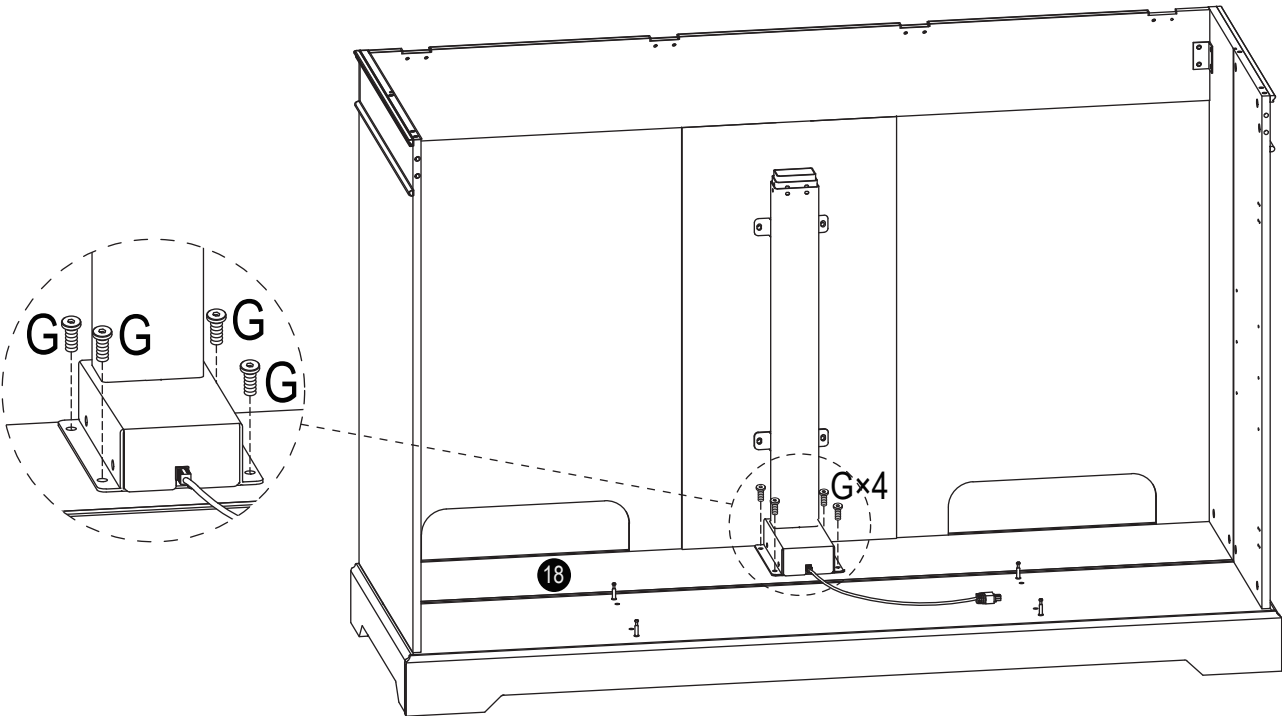

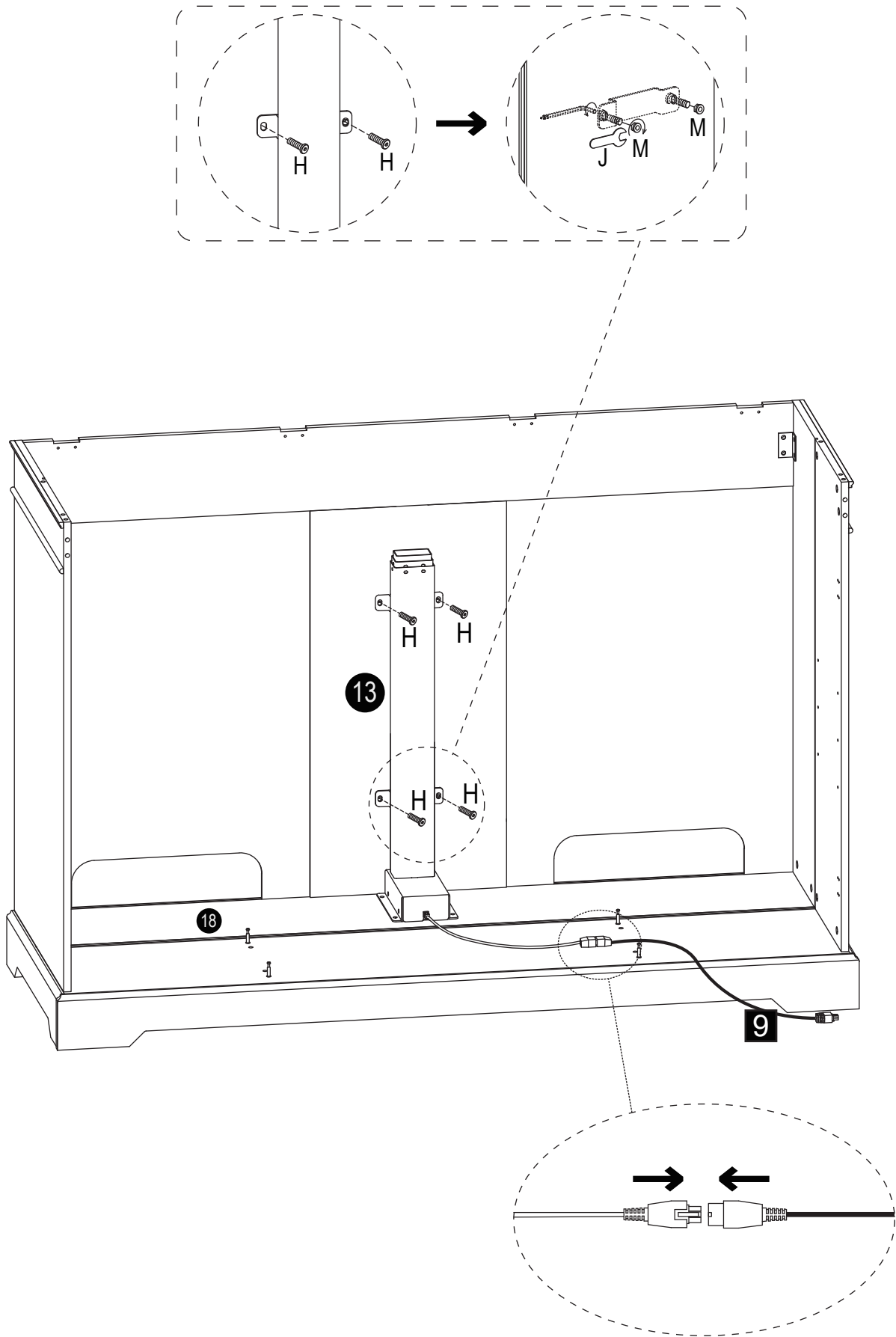

As shown, take out the main electric lift unit from the package. Use hardware G ×4 to attach the lift unit to the bottom panel #18. Do not fully tighten the hardware yet.

G	×4
	
M6×12mm	



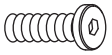

As shown, use hardware H \times 4 and nuts M \times 4 to secure the upper part of the electric lift unit to the back panel #13, then tighten them firmly.

Next, fully tighten the four hardware G from Step 17. Finally, take out the extension cable from the lift package and connect it to the control cable of the lift unit.

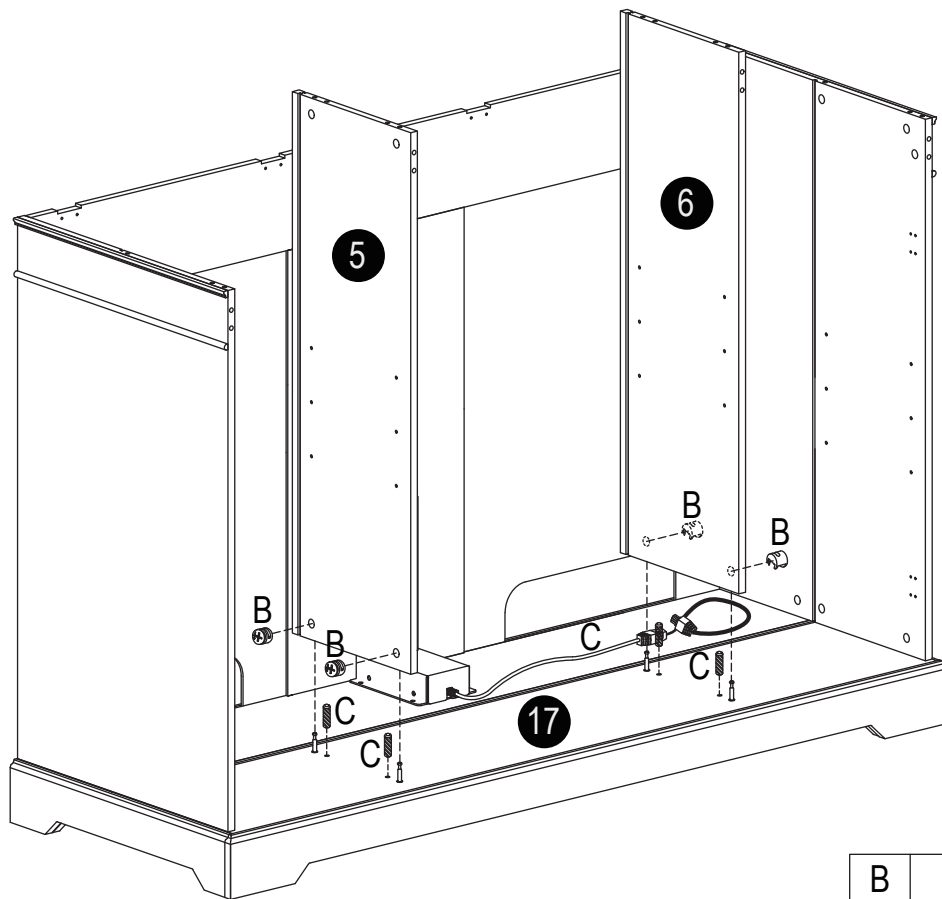
H	\times 4	J	\times 1	M	\times 4
					
M6 \times 25mm				M6	

19

As shown, insert wooden dowels C x4 into part #17, then use hardware A and B to connect parts #5 and #6 to part #17. Be careful not to pinch the control cable of the electric lift unit.

B	x4	C	x4
			
Ø15×12mm		Ø8×30mm	

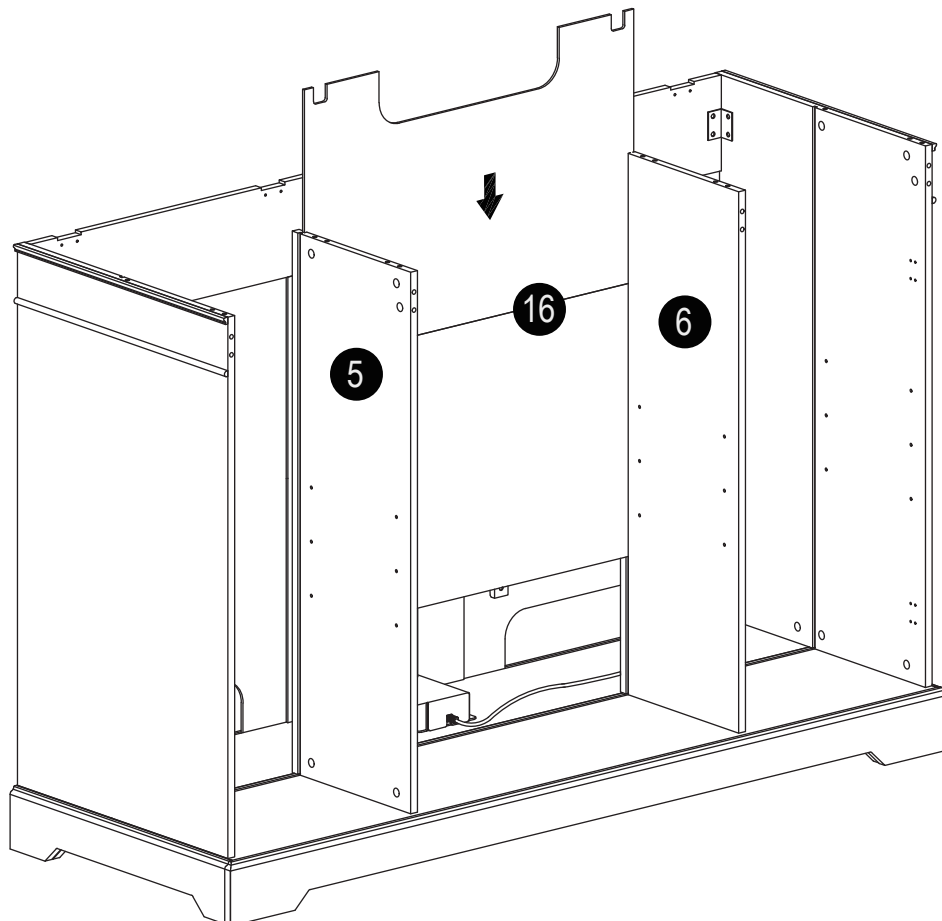
20

As shown, insert part #16 between parts #5 and #6. Be careful not to pinch the control cable of the electric lift unit.

21

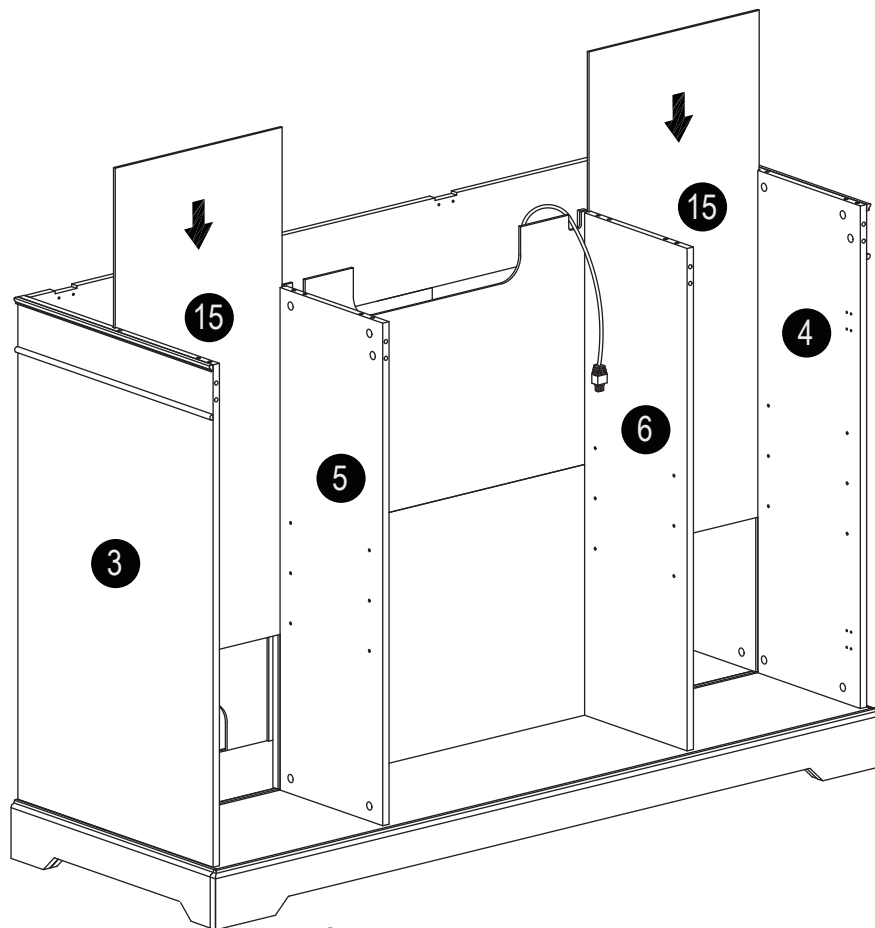

As shown, choose a suitable position for the controller based on your preference. Hang the lift control cable through the notch on back panel #16, then insert the two back panels #15 into place.

22

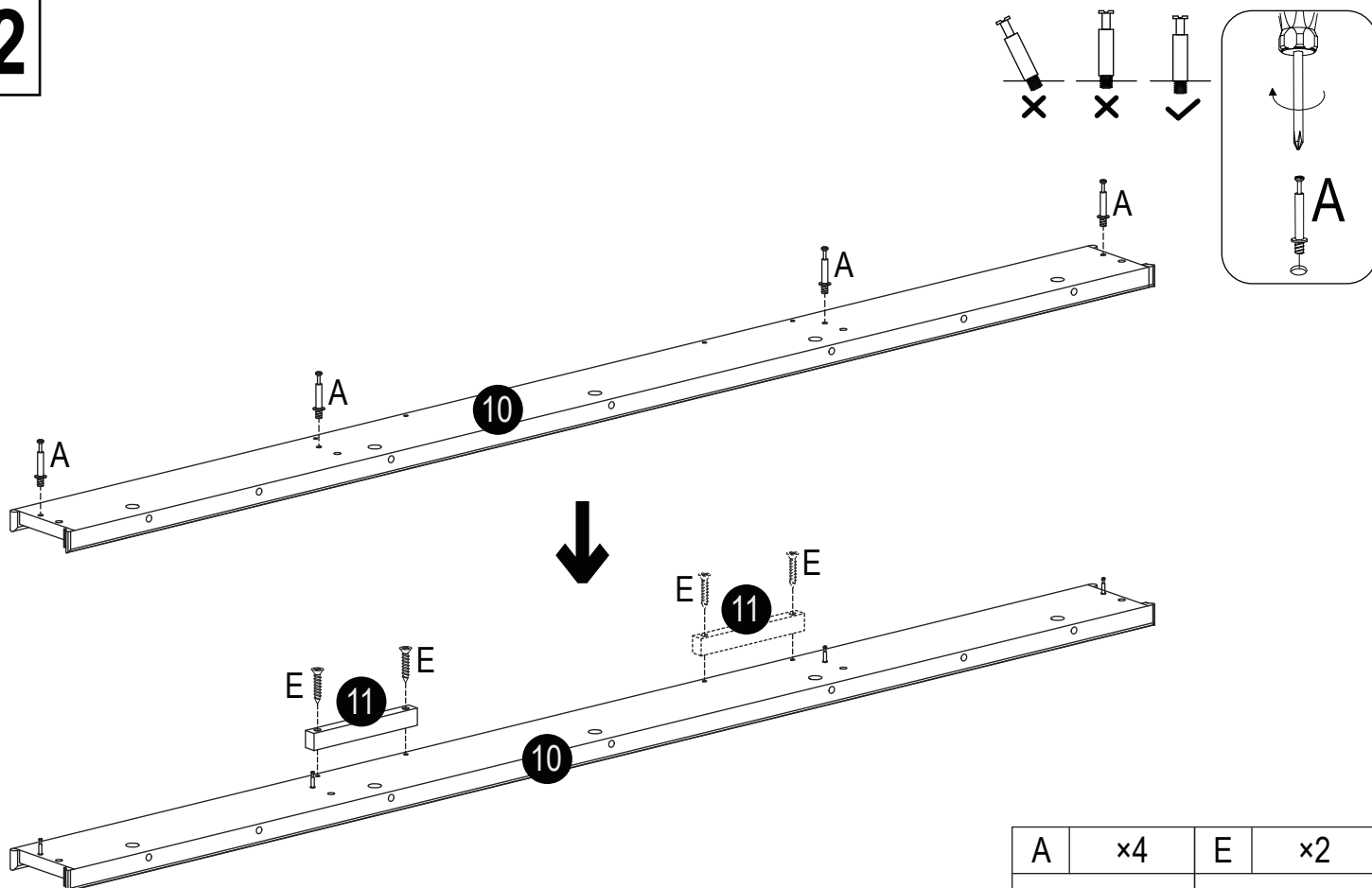

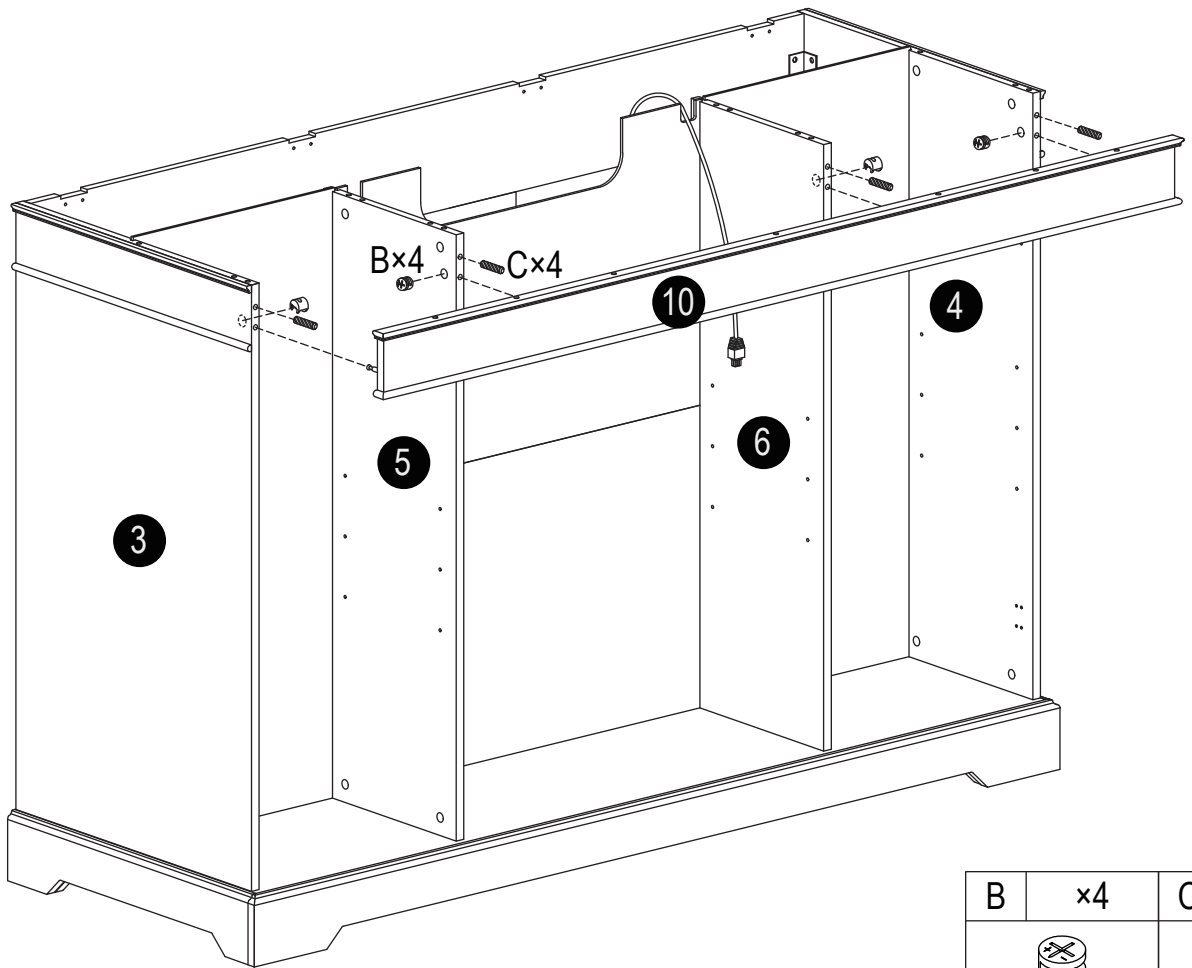

As shown, install hardware A x4 onto part #10 first. Then, using hardware E, attach part #10 according to the position of the lift control cable. Make sure the two pilot holes on part #11 face outward for controller installation.

23



As shown, insert wooden dowels C ×4 into parts #3, #4, #5, and #6.
Then attach the assembled part #10 to these panels using hardware A and B.

B	×4	C	×4
			
Ø15×12mm		Ø8×30mm	

24

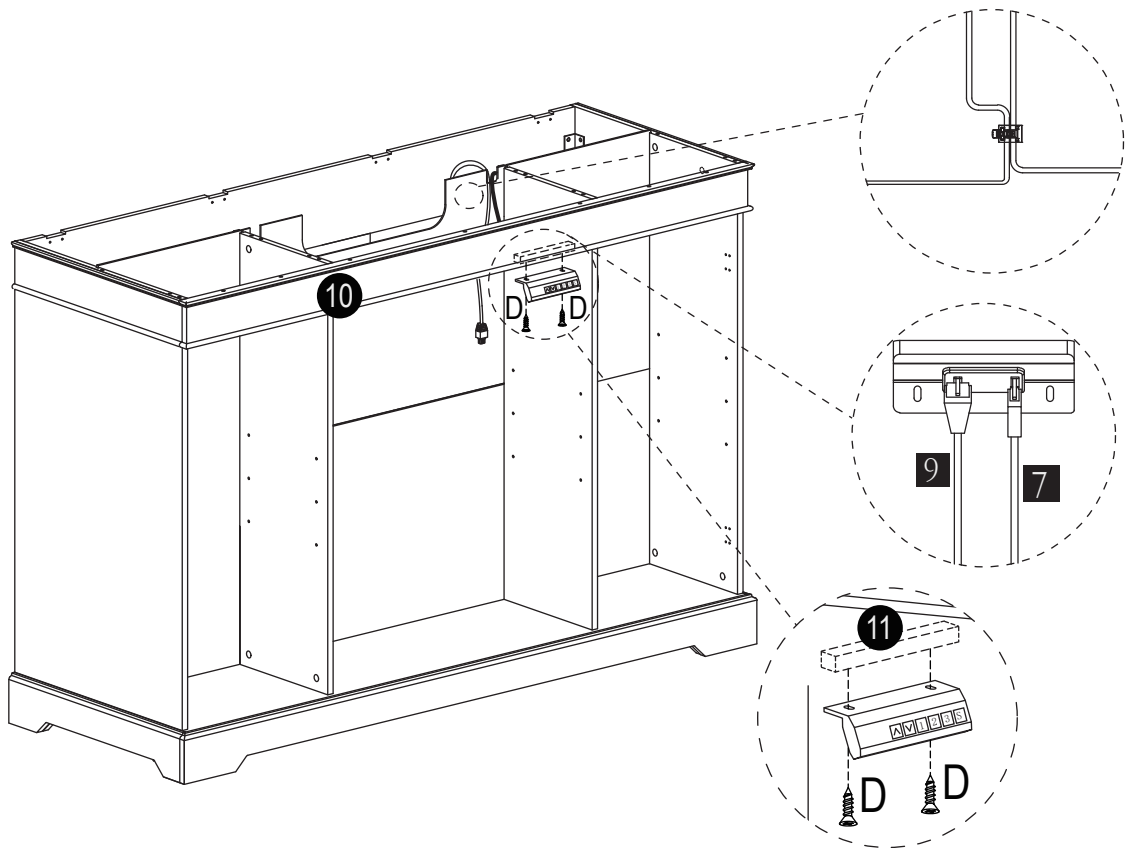

As shown, take the control panel #8 from the lift package and secure it to part #10 using 2 pcs of screw D.
Then take the power adapter #7 from the lift package and connect it to the control panel.
Next, connect the main lift control extension cable #9 to the control panel as well.
After leaving an appropriate cable length, take the cable tie C from the lift package, neatly secure the wires, remove the adhesive backing, and stick it in a suitable position.

D	×2
	
Ø3.5×14mm	

25

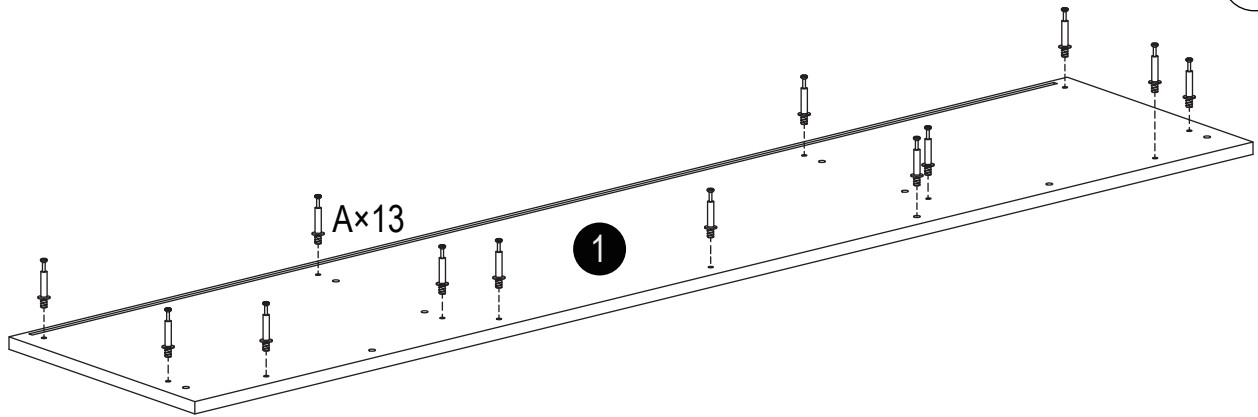
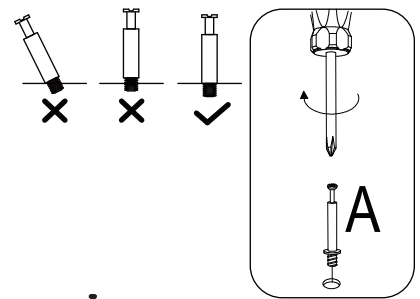

A	x13
Ø6x35mm	

As shown, install hardware A x13 onto part #1.
 Note: The larger holes are reserved for wooden dowels.

26

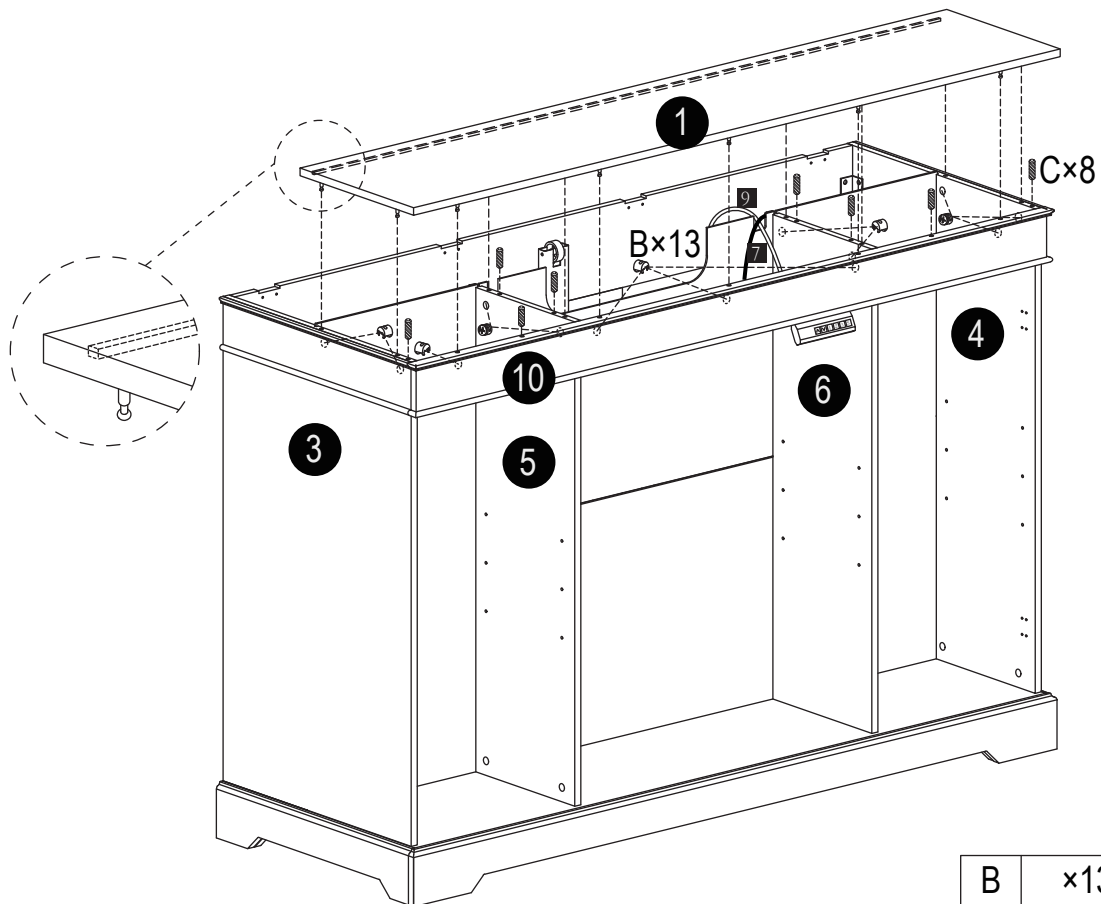

B	x13	C	x8
Ø15x12mm		Ø8x30mm	

As shown, insert wooden dowels C x8 into the corresponding holes on parts #3, #4, and #10.
 Then attach part #1 using hardware A and B.

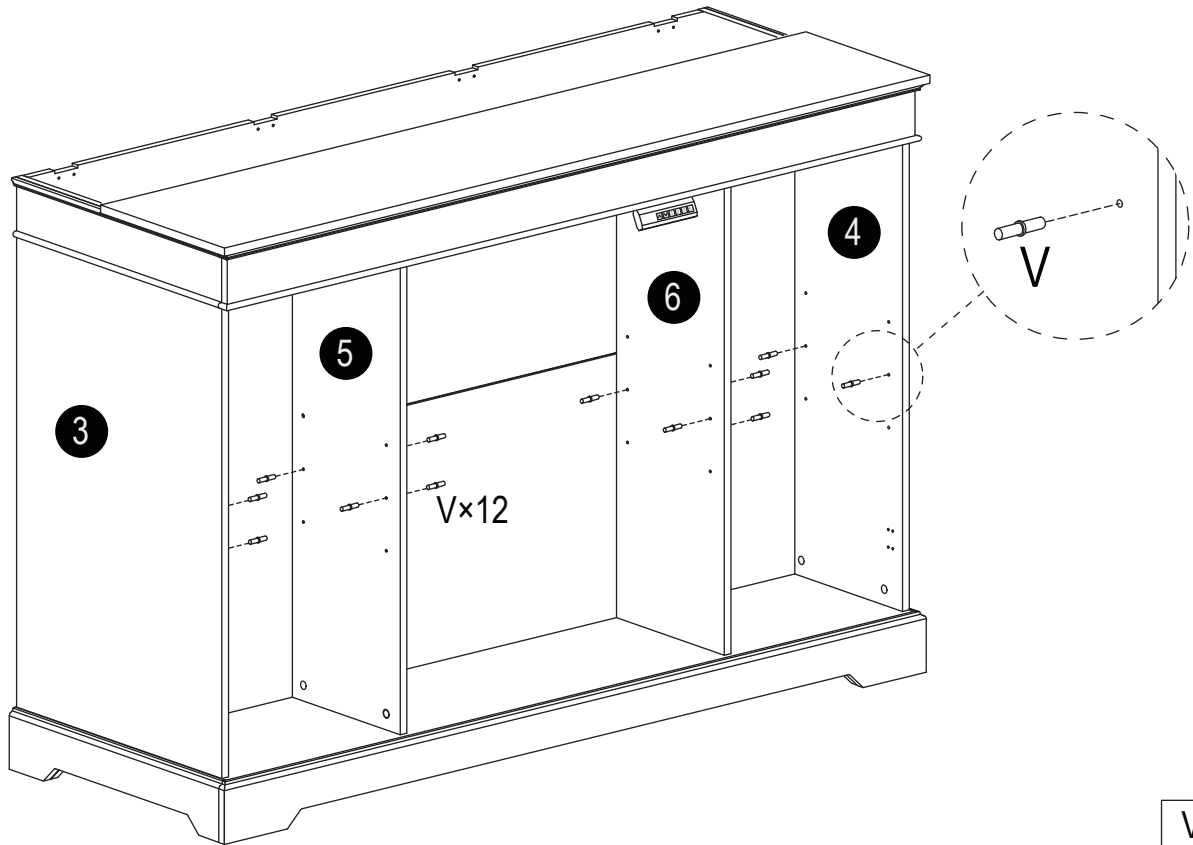
27

We provide three height options for the shelves. Insert hardware V x12 into the desired holes according to your preferred shelf height.



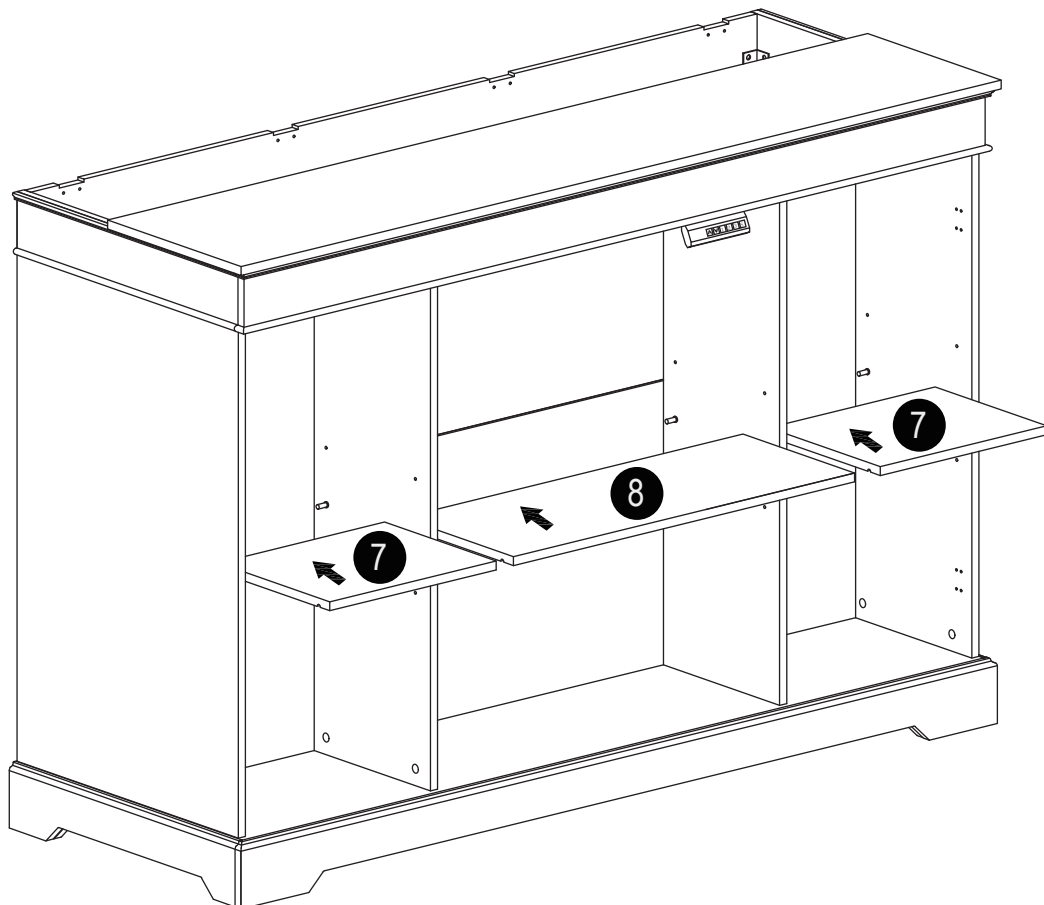

V	x12
	
Ø5x13mm	

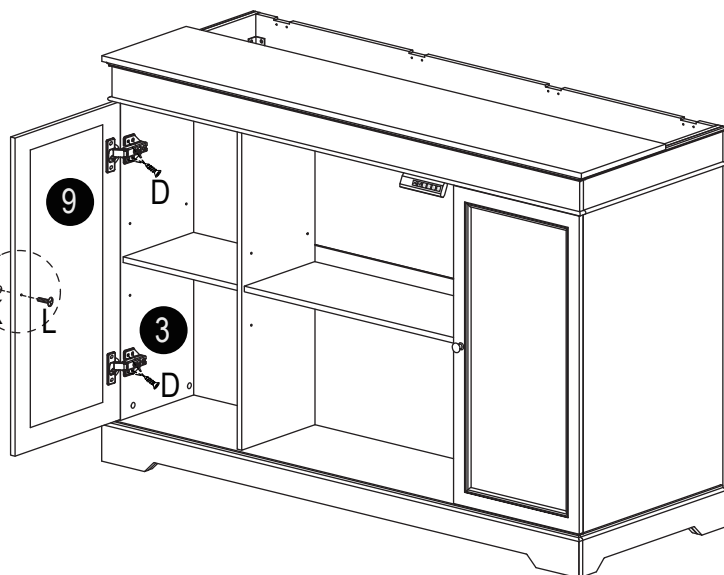
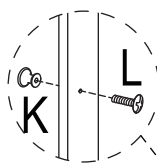
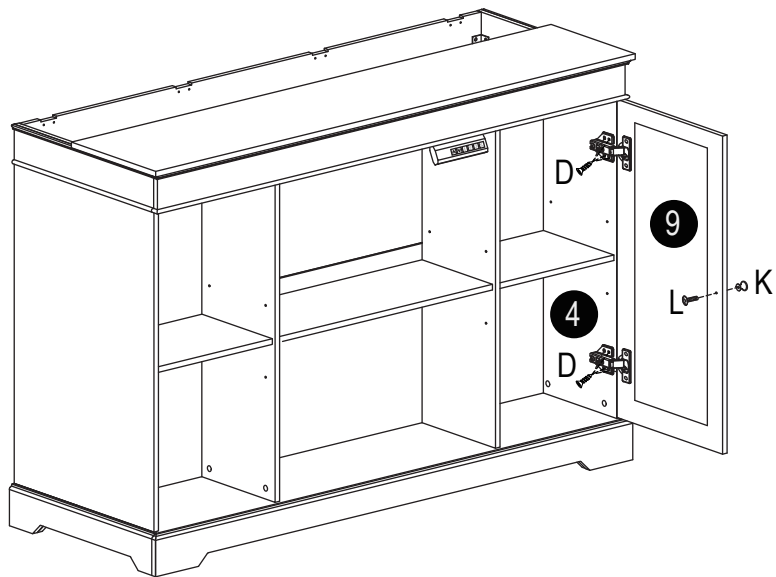
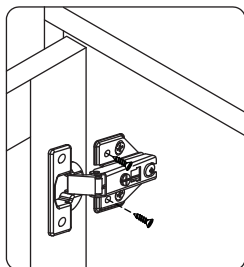
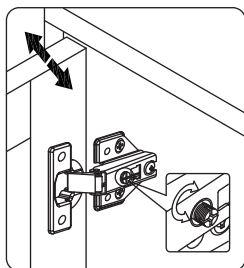
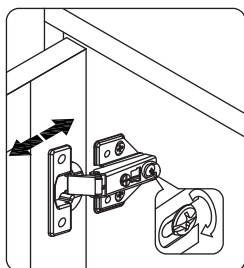
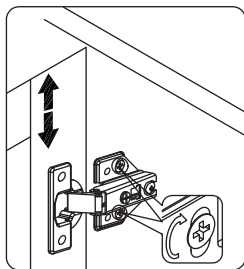
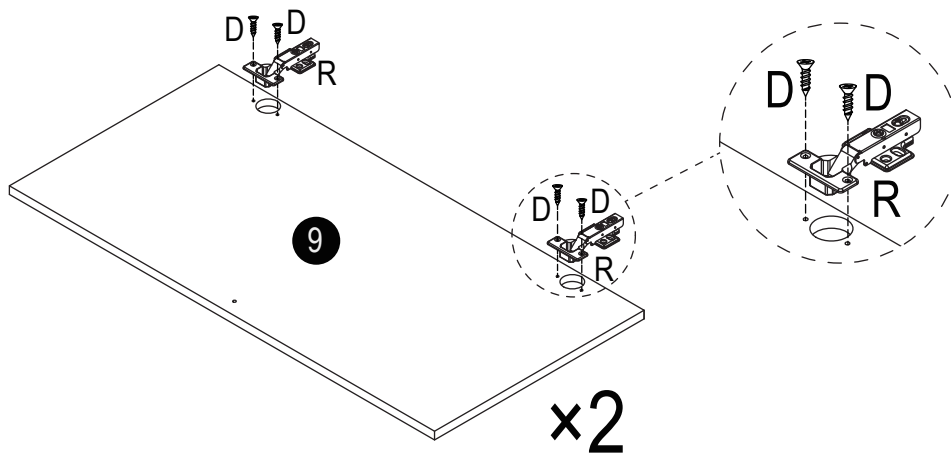
28

As shown, place shelves #7 x2 and #8 into the desired positions.



As shown, attach hinges R × 4 to doors #9 × 2 using hardware D × 8.
 Then mount the two doors #9 to parts #3 and #4 using hardware D.
 Finally, install door handles K × 2 onto doors #9 using screws L × 2.

D	×24	K	×2	L	×2	R	×4
							
Ø3.5×14mm		Ø25×21mm		M4×18mm			

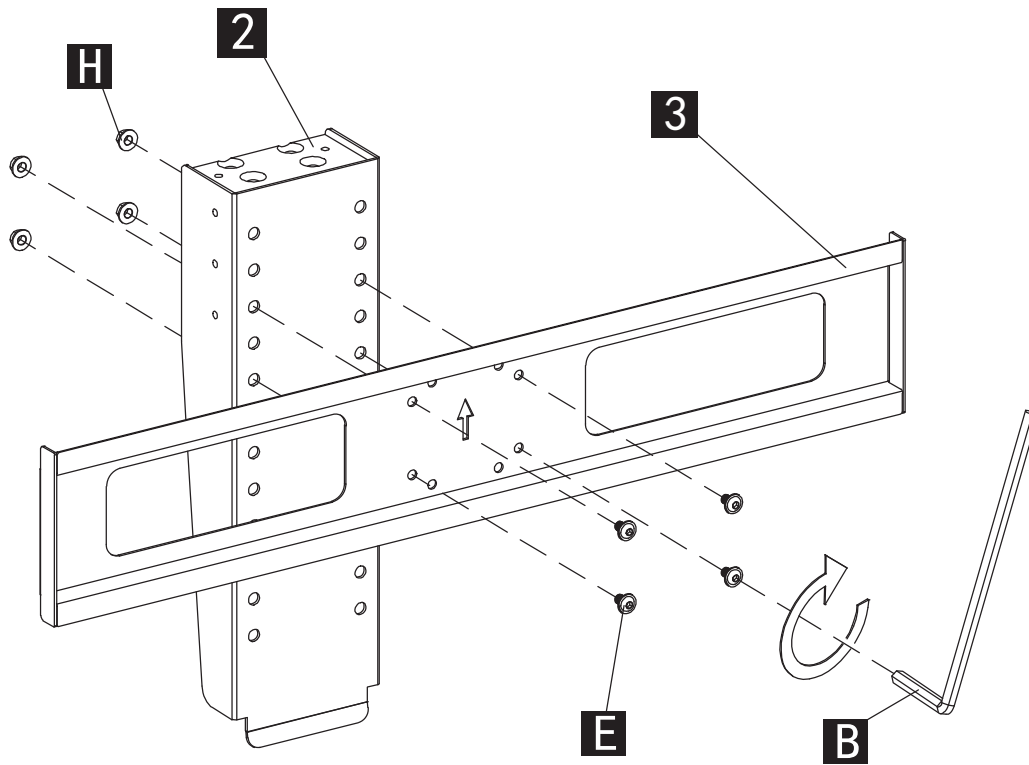
30

Take parts #2 and #3 from the lift package.

As shown, attach them together using screws E and nuts H, and make sure the bracket is level.

Note: Check the mounting hole height on the back of your TV and choose the proper position before tightening.

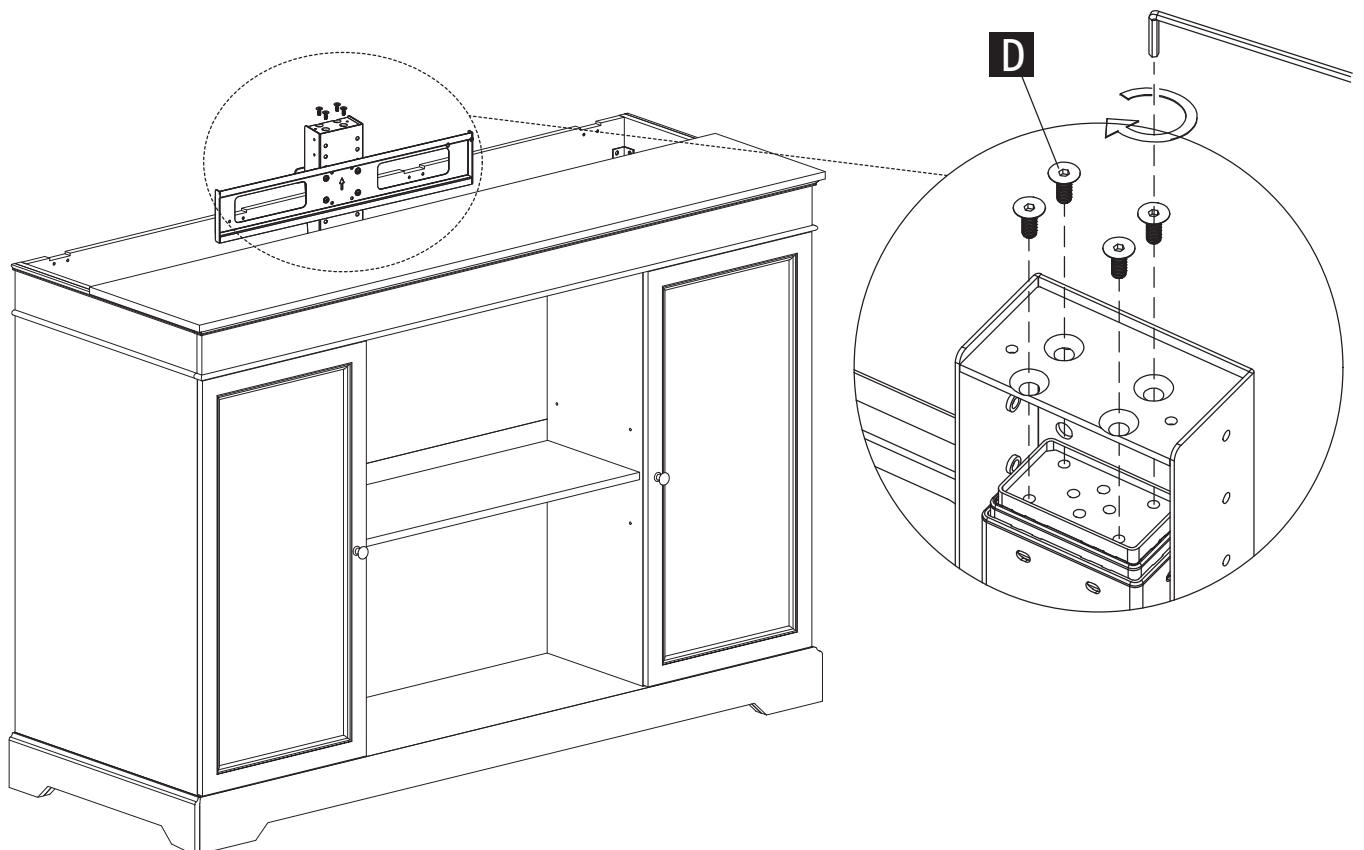
31

Connect the lift to the power supply and raise the lifting panel to a suitable height.

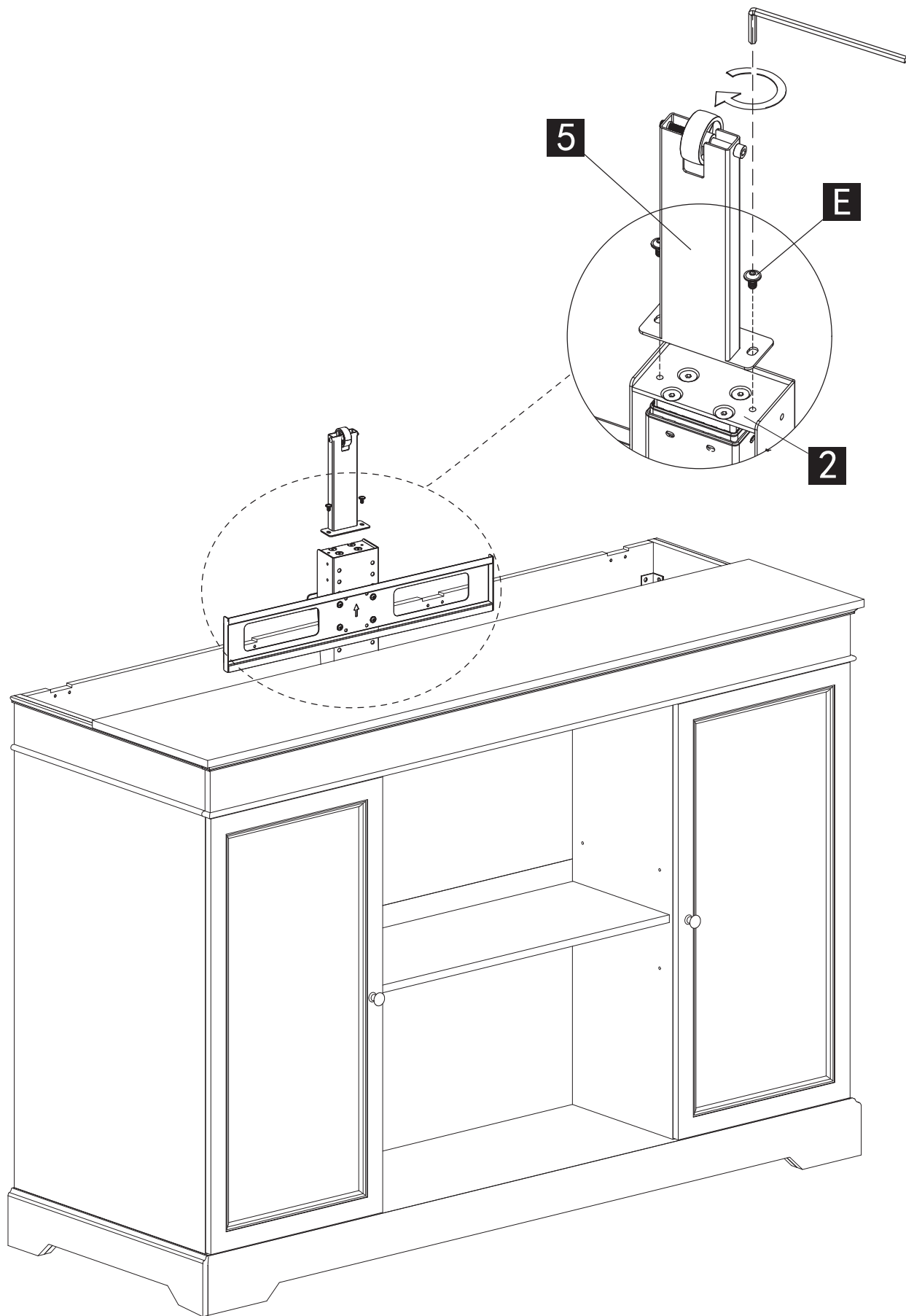

As shown, attach the assembled bracket from the previous step to the lift motor housing using screws D ×4.

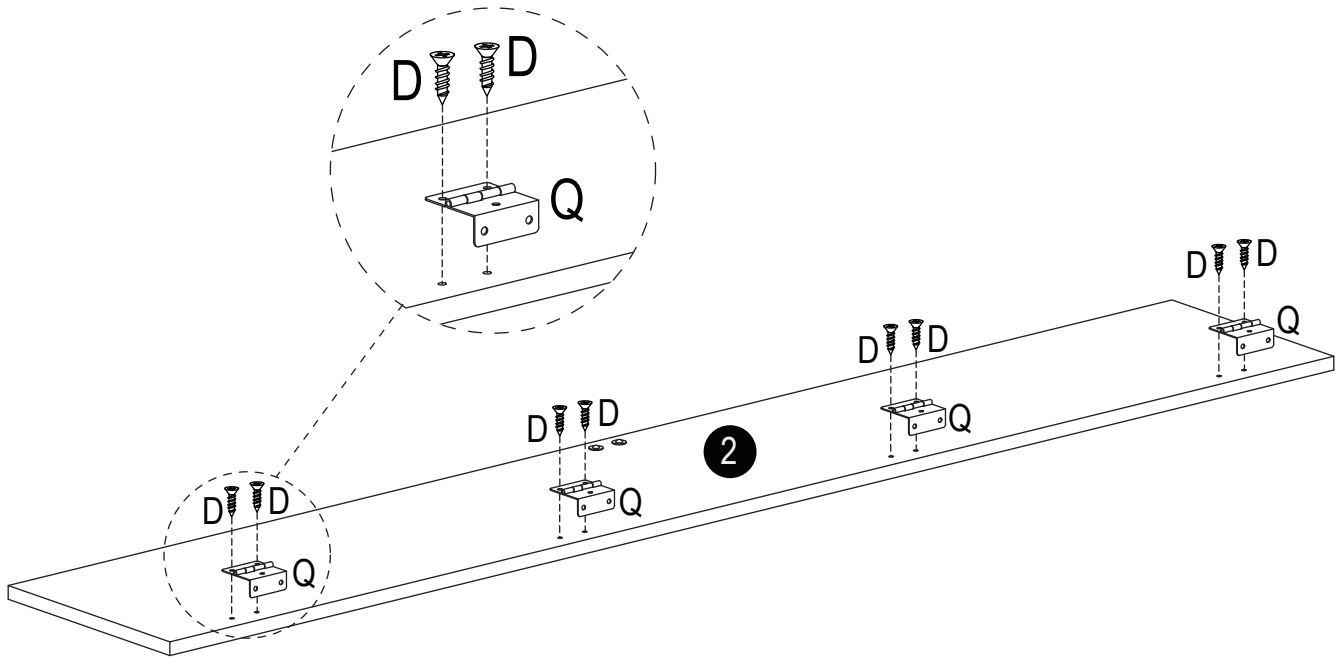

As shown, attach the support rods #5 to the mounting plate #2 using M6×10mm screws (E). Tighten all screws securely with the 4mm Allen wrench (B). Ensure the interface between the mounting plate #2 and the support rods #5 is flush and properly aligned.

33



D	x8	Q	x4
			
Ø3.5x14mm		51x27mm	

As shown, attach the hinges Q x4 to part #2 using screws D x8. Ensure all hinges are aligned properly before tightening the screws.

34

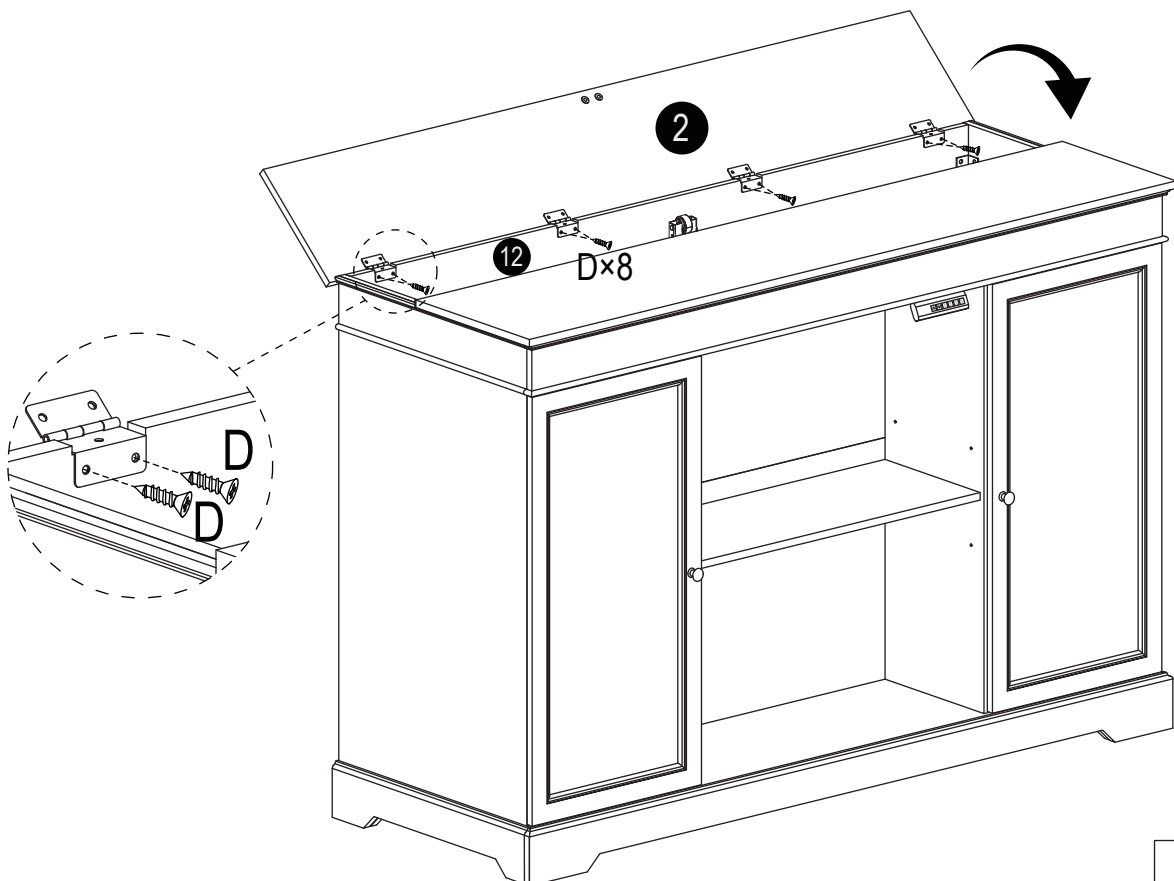

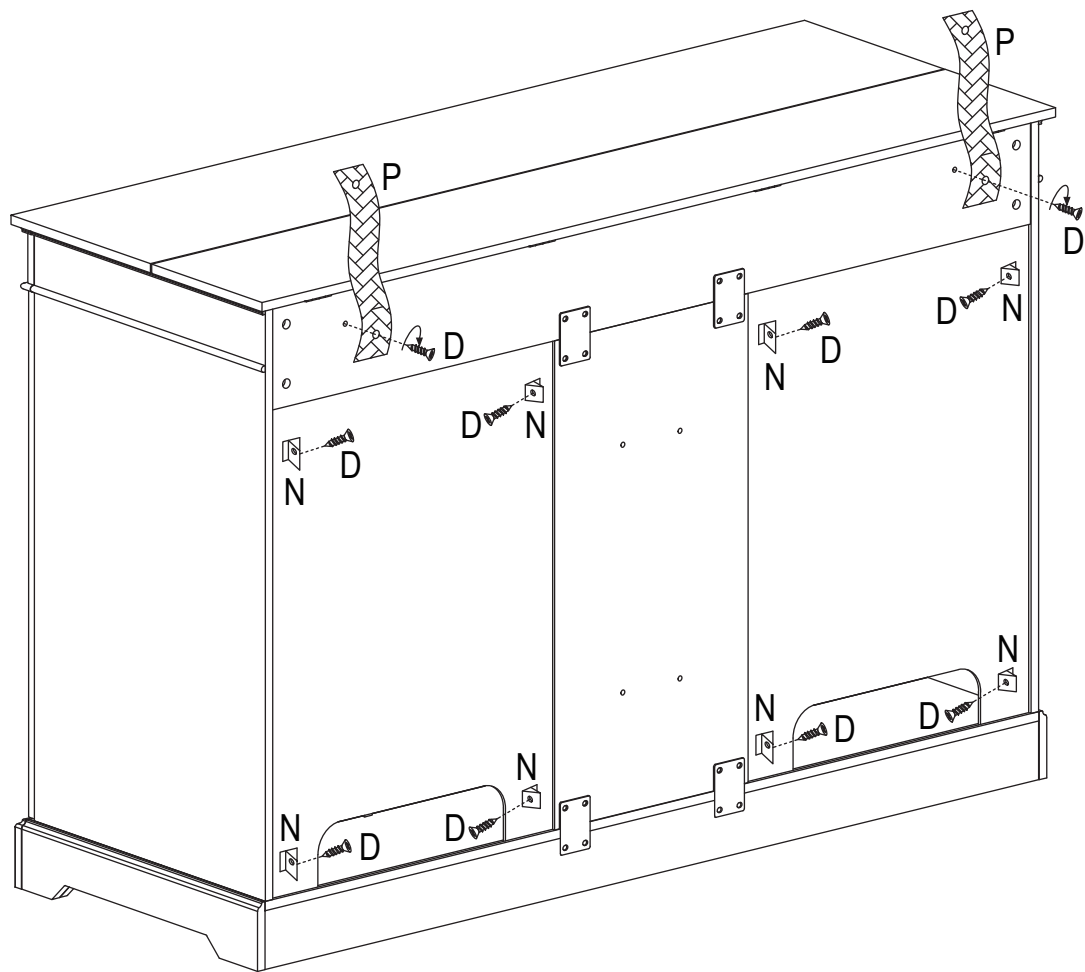

D	x8
	
Ø3.5x14mm	

As shown, attach part (2) to part (12) using screws D x8. Make sure the hinges are properly aligned and the top panel opens and closes smoothly.



Install Back Buckle N x8 to backside Part #14 with Screws D x8 as shown to make the product more stable. Lock the strip Px2 to part 1 with the short screw Dx2 as shown in the picture and wait for the back to lock to the wall.

D	x10	N	x8	P	x2
					
Ø3.5×14mm		14×14×9mm		155×20mm	

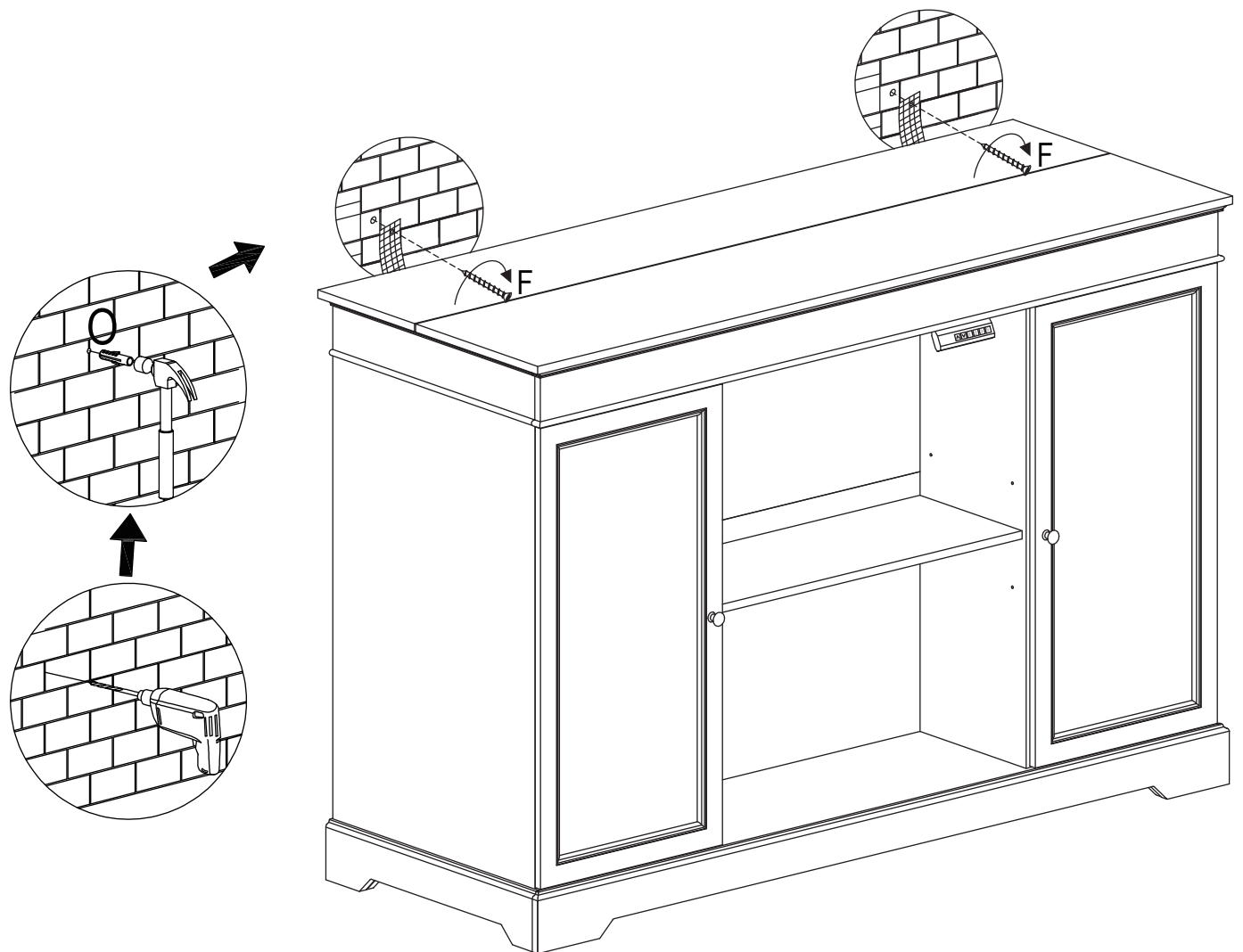

Cabinet must permanently fixed to the wall with included anti-tipping device to prevent the cabinet from tipping over.

Mark the drill position on the wall with a pencil.

Drill holes on the marked position using a bit.

Gently insert the wall anchor (O) into the drilled hole with the help of a hammer.

As shown in the picture, insert long screw F X 2 into the cloth strip and lock it into the wall for fixing

F	x2+1	O	x2
Ø4x35mm		Ø8x40mm	

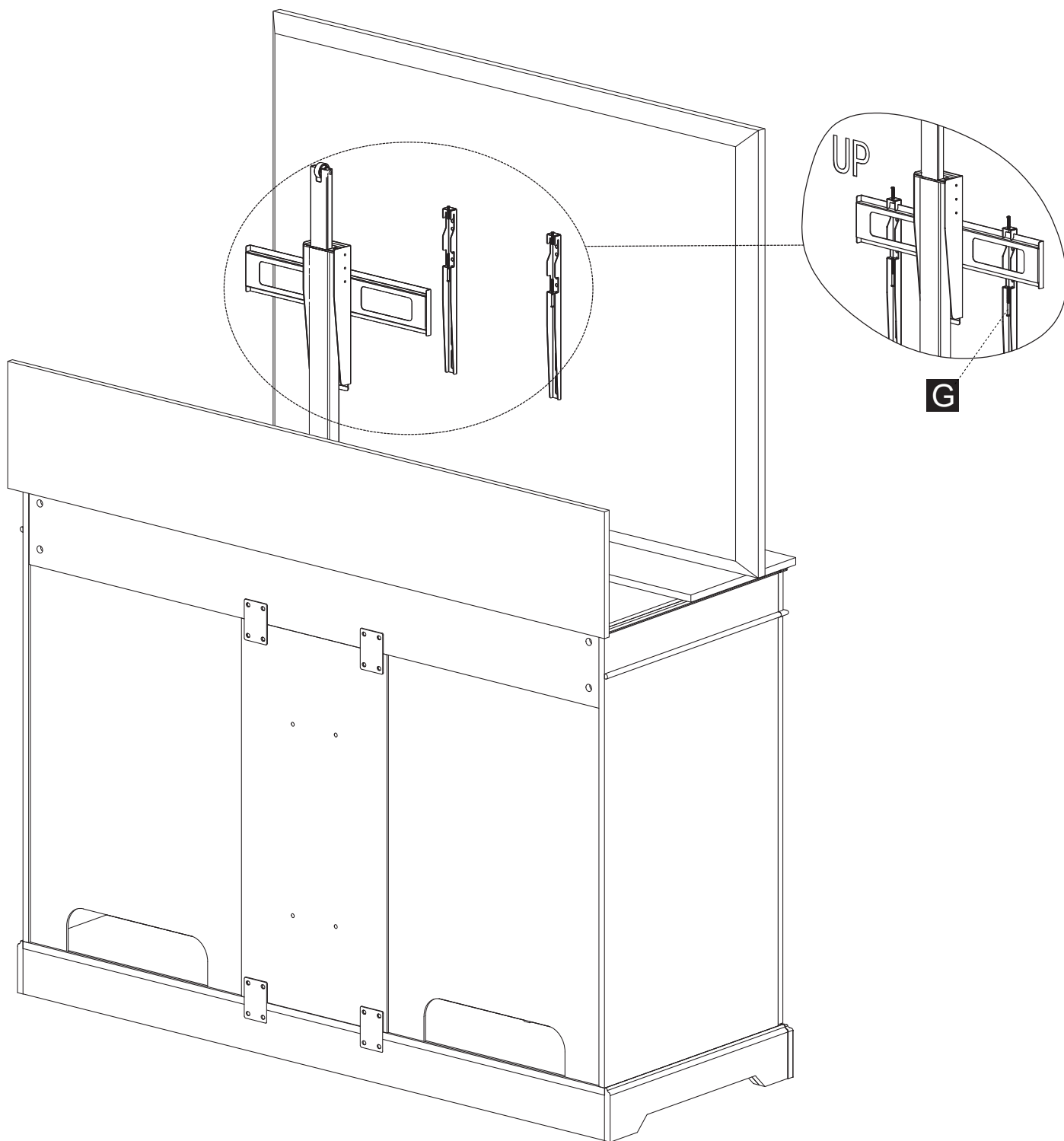

Following the instructions in the lift package, attach the mounting brackets to the back of your TV.

Raise the lift to its highest position, then carefully hang the TV onto the installed brackets. Ensure the TV is centered on the mount, and tighten screws G securely.