

ASSEMBLY INSTRUCTIONS

Item NO.: YJJ250088

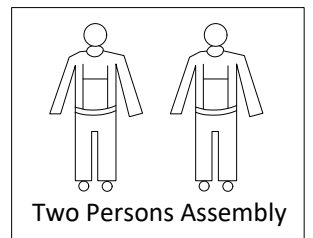

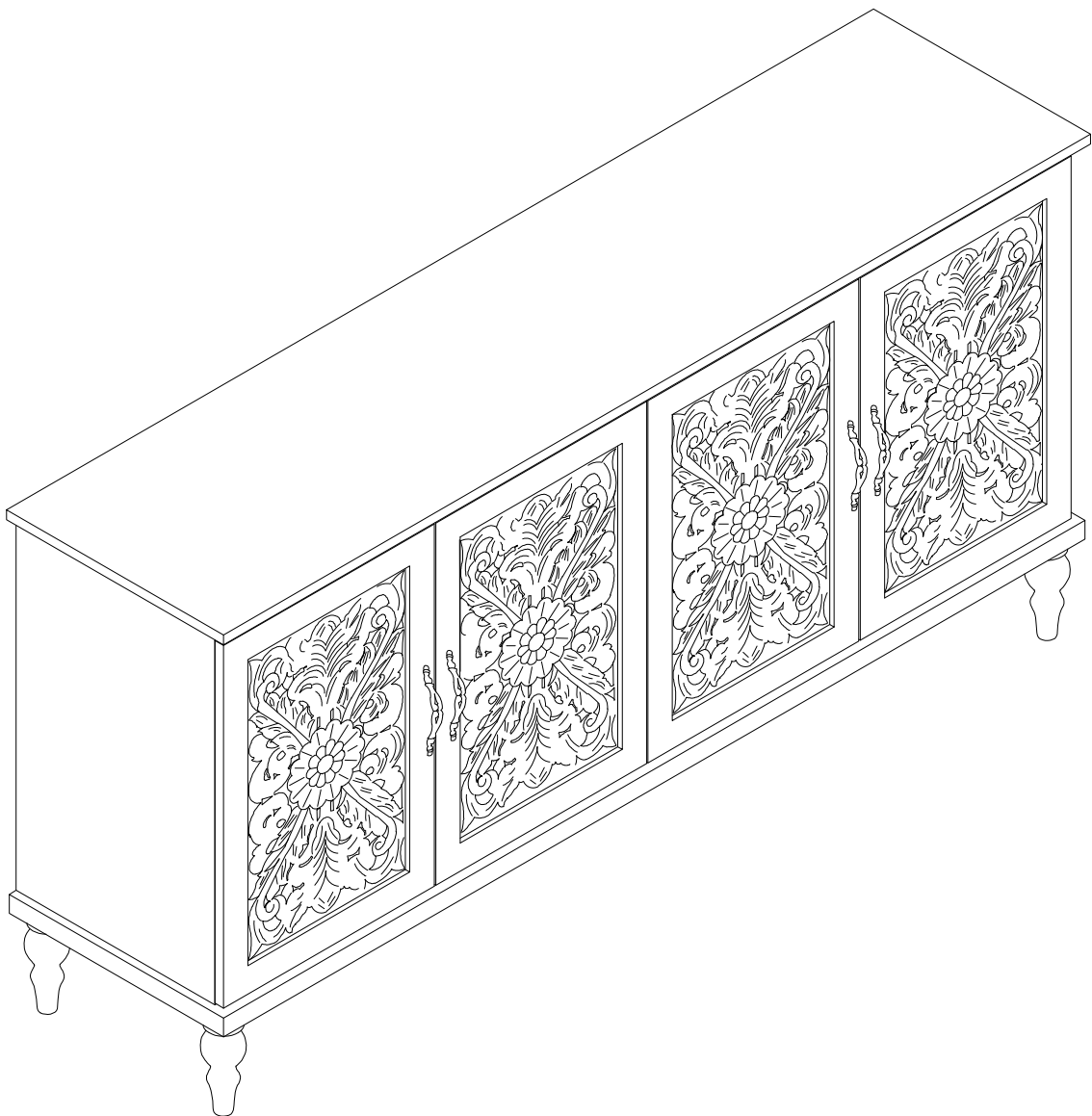
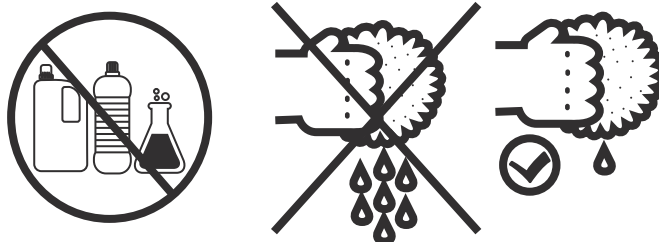
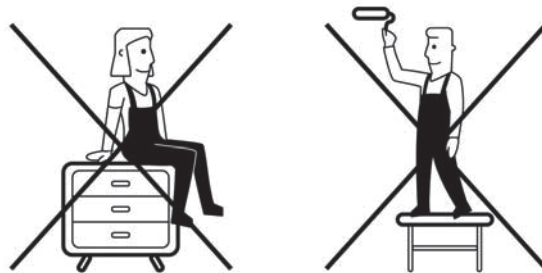
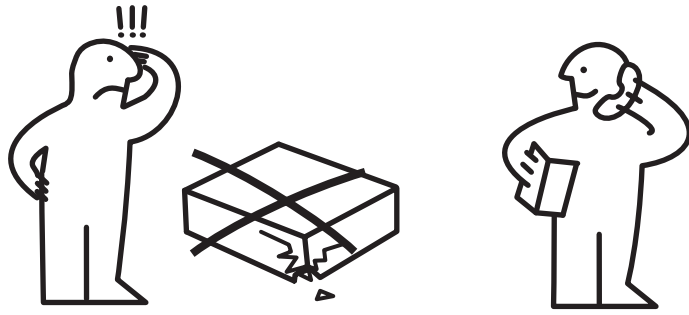

ASSEMBLY TOOLS REQUIRED (NOT INCLUDED)

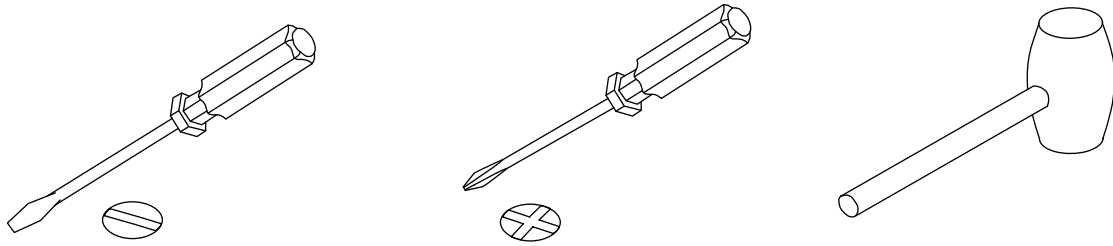

- * Before discarding packing materials, please check all parts and hardware are presented.
- * Please follow the instructions closely.
- * After few days of initial assembly, the product may have acclimated to new environment, please tighten all hardware again.

Dowel Installation

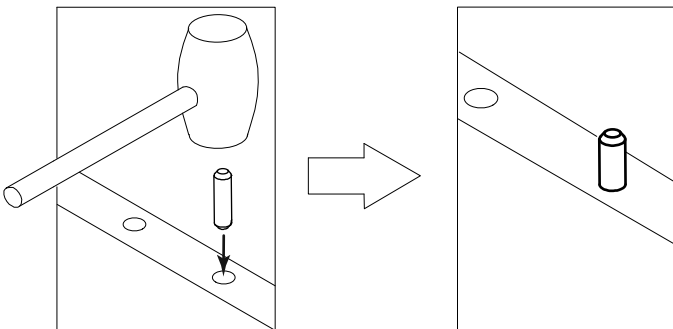

Gently tap dowel into hole with rubber mallet.

CAM-LOCK

Tighten until shoulder is flush with panel. Do not overtighten or undertighten

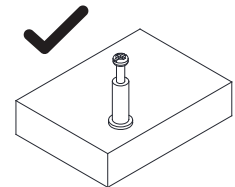
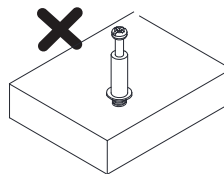
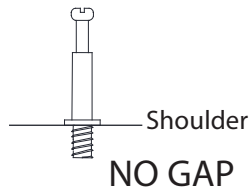

WHEN FITTING CAMS

ENSURE STARTING POSITION IS CORRECT BEFORE YOU INSERT CONNECTING CAM-PILLAR
TURN CLOCKWISE UNTIL SECURE

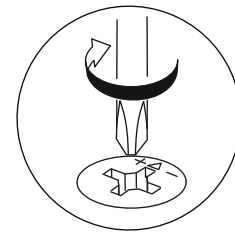
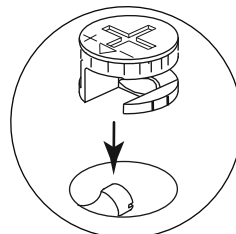
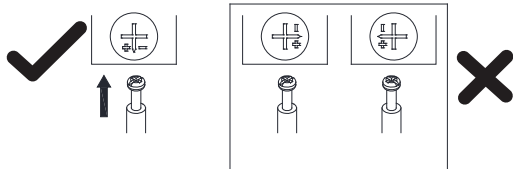

Laying out all the parts and hardware and identifying each part as shown below. It may help you when you assemble the item.

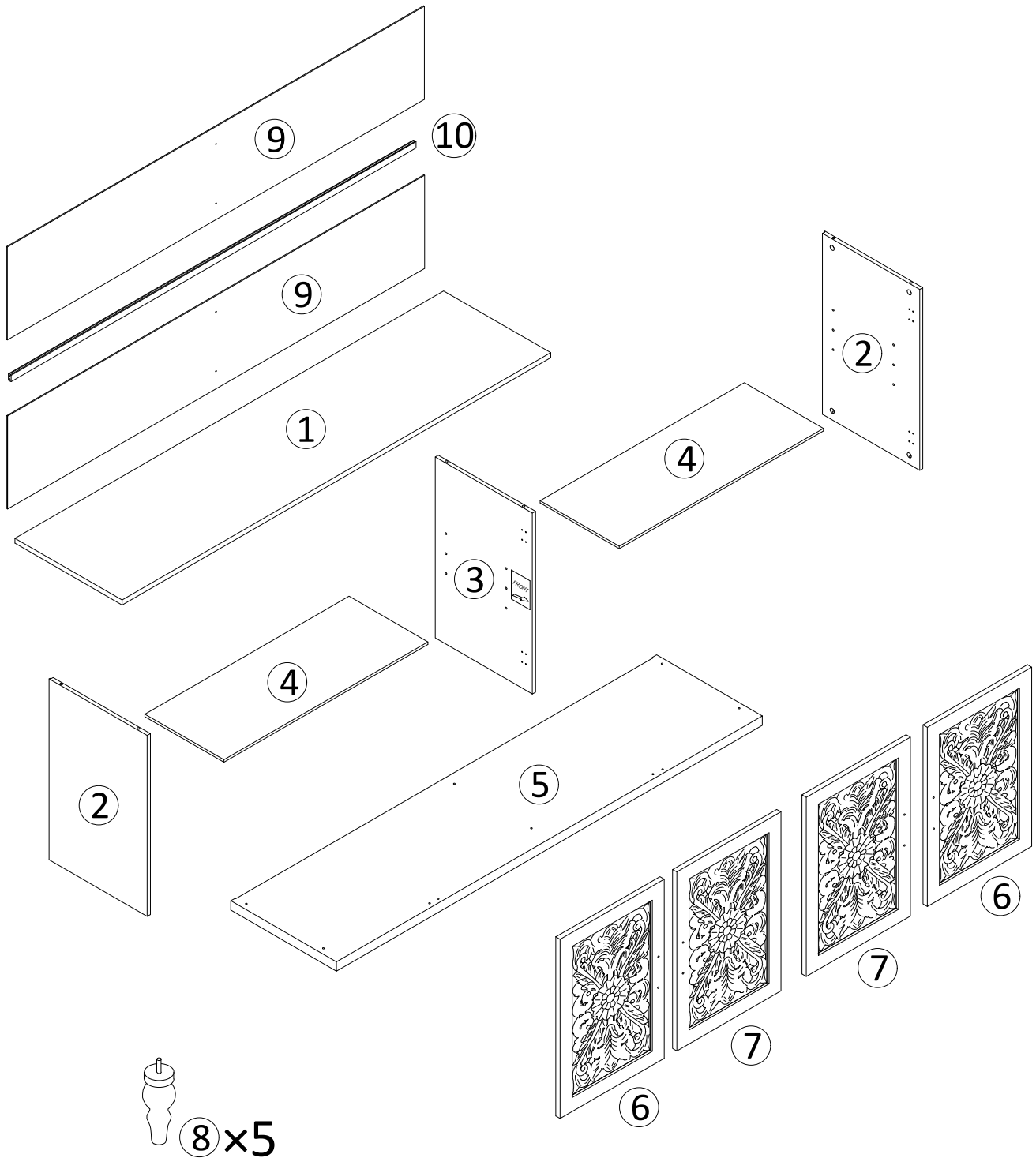

① × 1	② × 2	③ × 1	④ × 2	⑤ × 1	⑥ × 2
⑦ × 2	⑧ × 5	⑨ × 2	⑩ × 1		

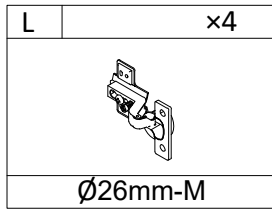
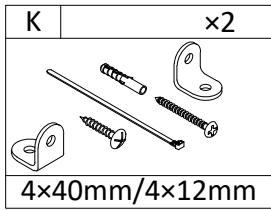
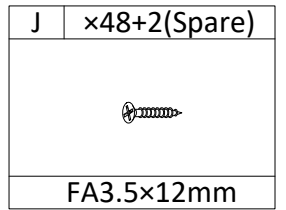
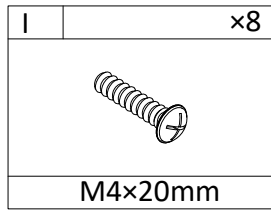
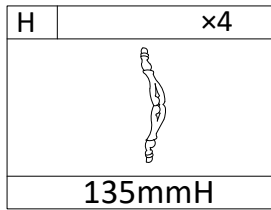
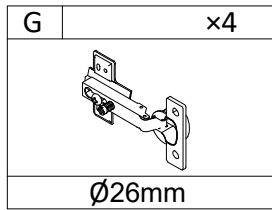
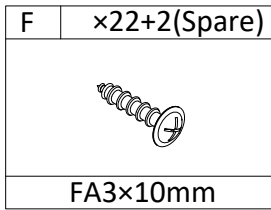
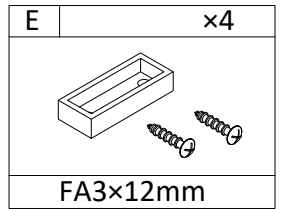
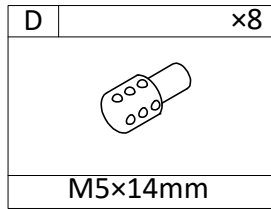
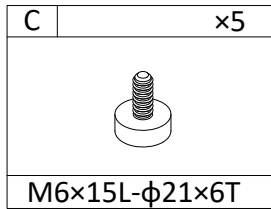
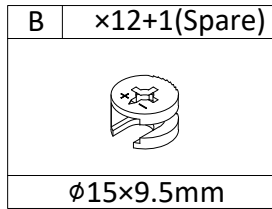
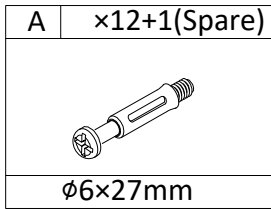

3

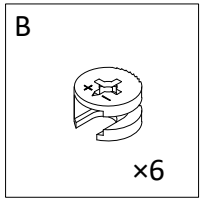
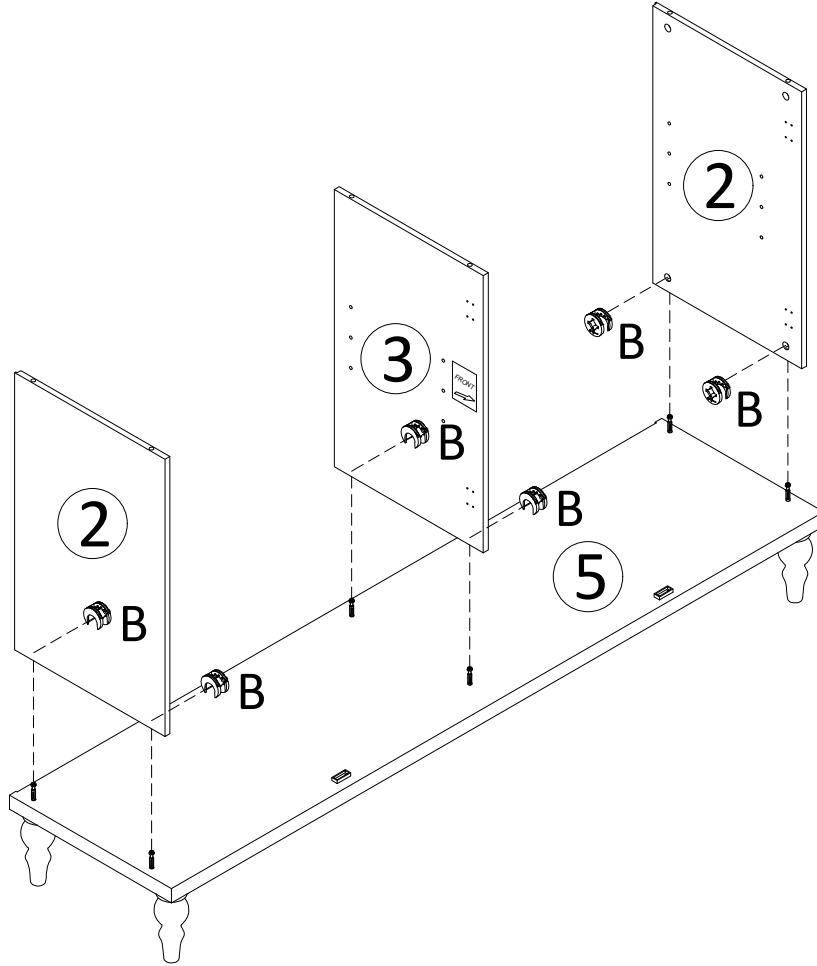

4

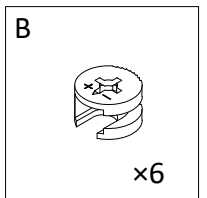
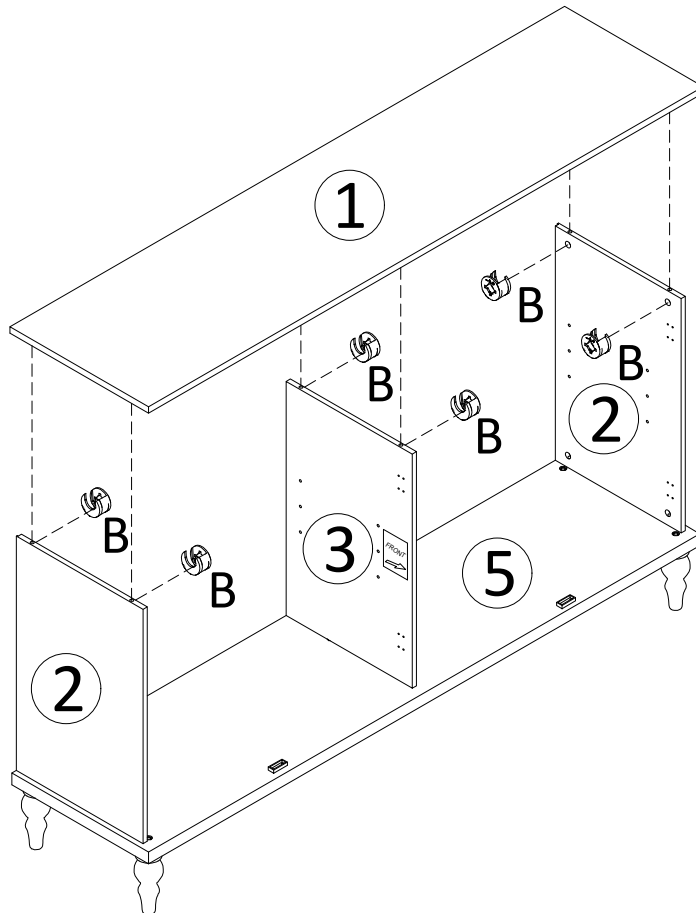

5

180°

Turn the screws vertically from slow to fast.

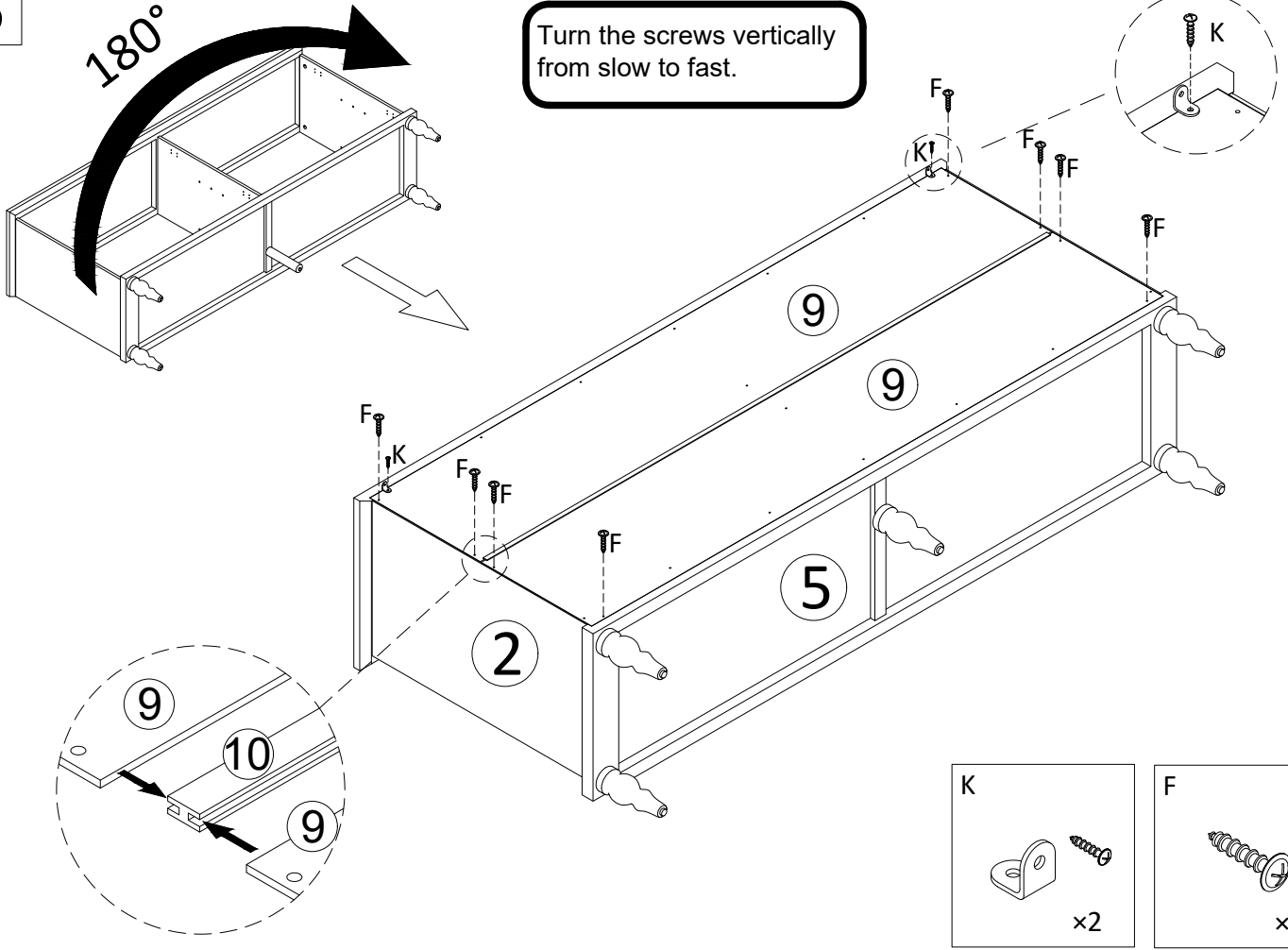

6

Turn the screws vertically from slow to fast.

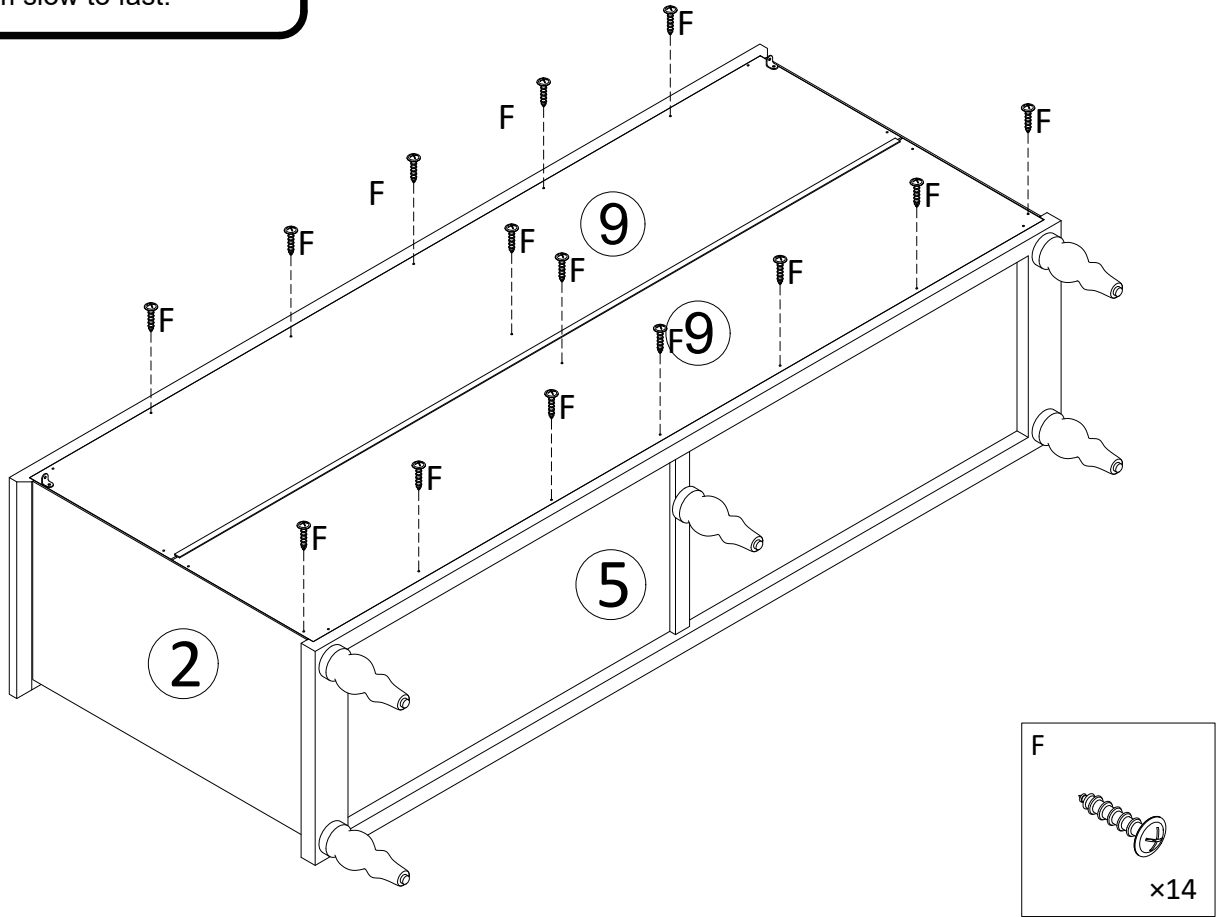

7

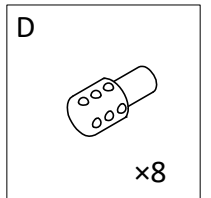
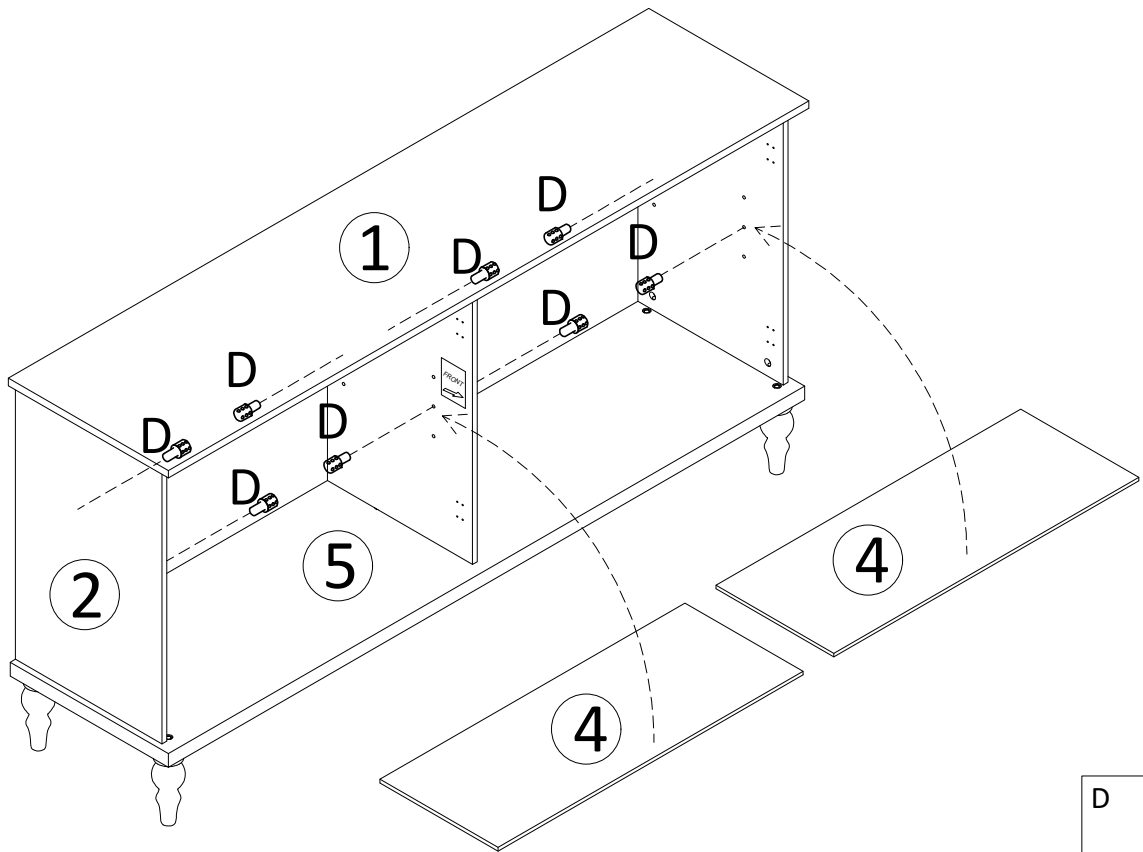

8

Turn the screws vertically from slow to fast.

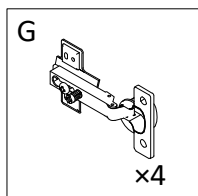
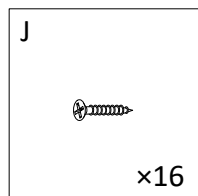
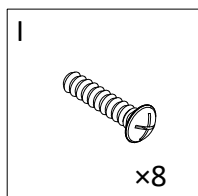
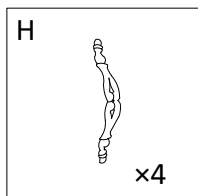
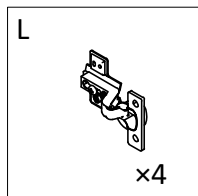
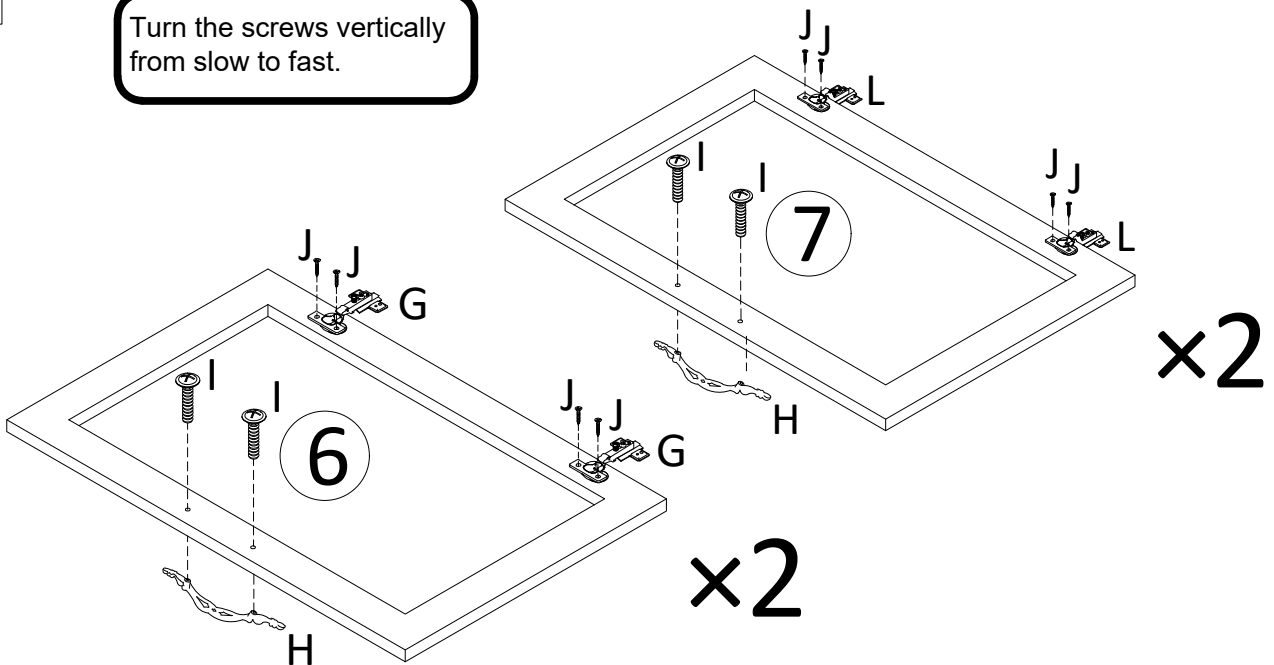

STEP (1)

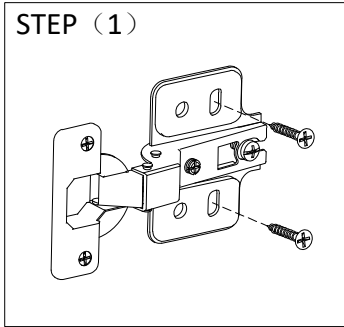

Tips: Turning the screw to approx 50% tightness, don't be fully tight.

STEP (2)

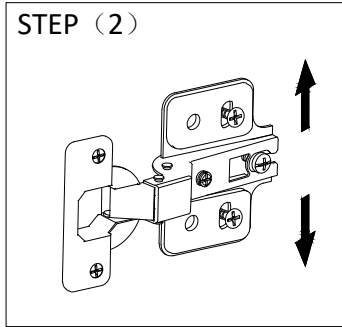

Tips: Moving the hinges up or down appropriately to adjust the gap between the door with the cabinet top and bottom.

STEP (3)

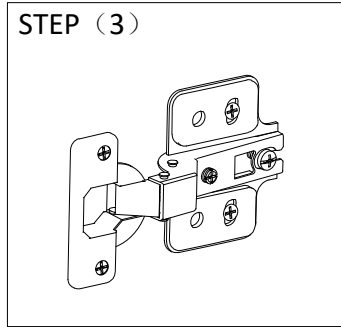

Tips: Tightening the screws completely.

STEP (4)

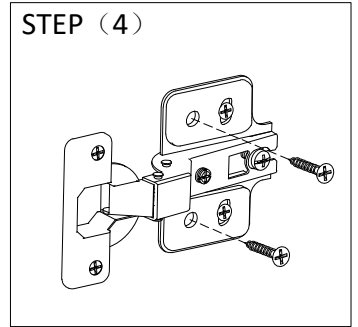

Tips: Tightening the other screws completely.

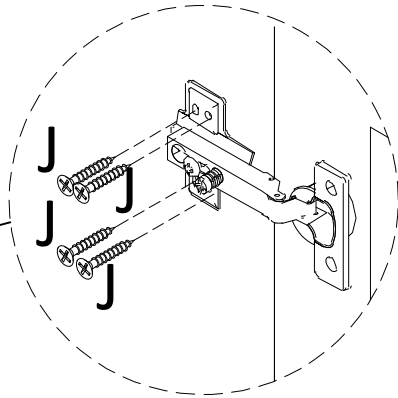
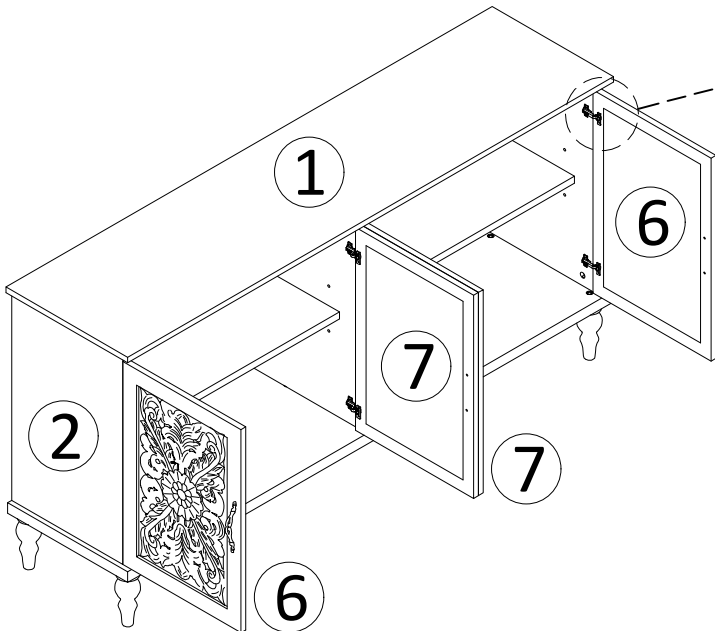

Turn the screws vertically from slow to fast.

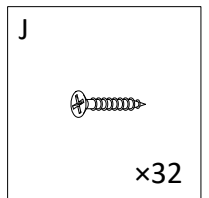
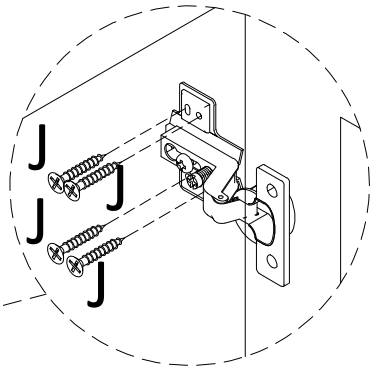
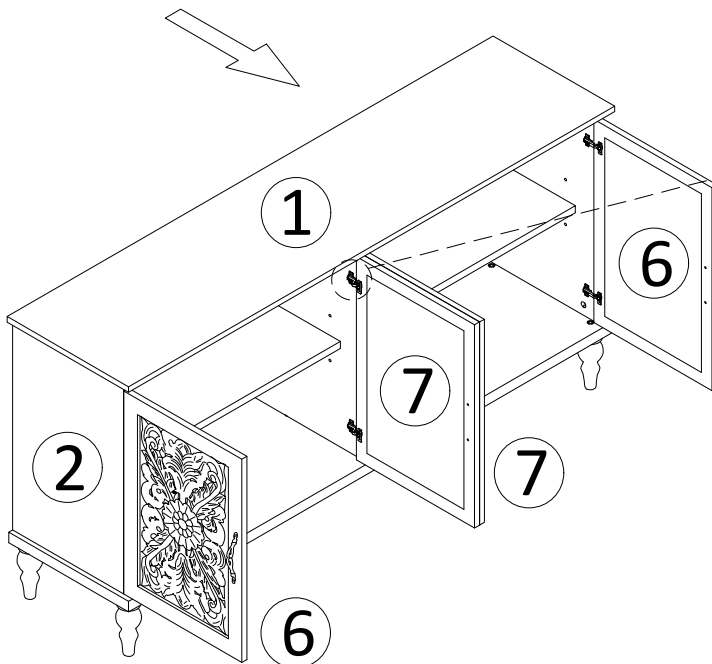

10 Tips: If the gap between the doors with the partition panel is too far or close, please turning the screw as shown below .

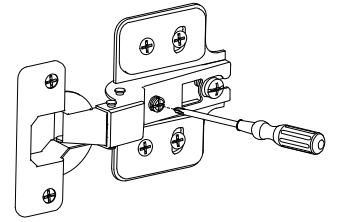
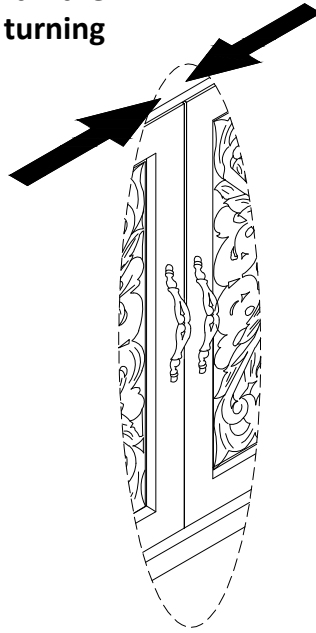
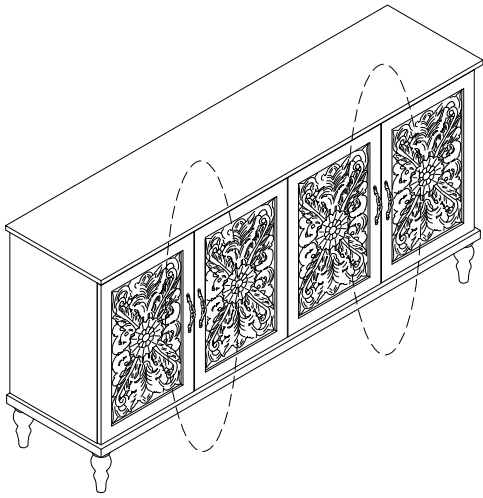

Tips: Adjusting the screw as shown in the following picture can make the door move forward or backward.

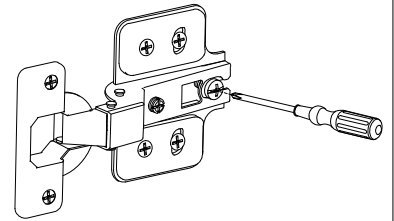
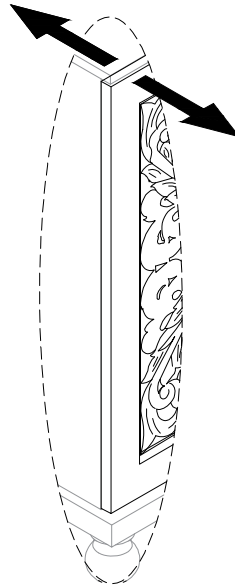
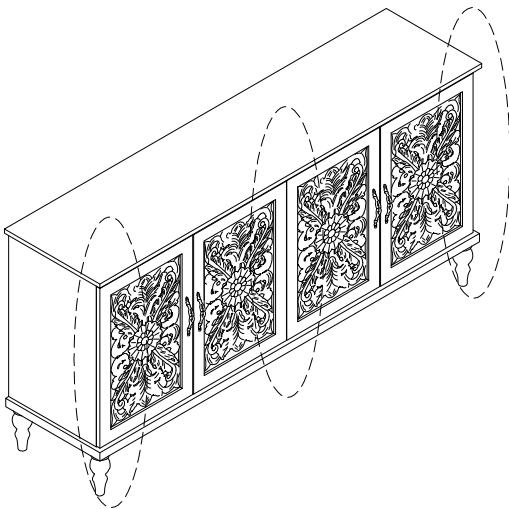

Tips: Adjusting the levelers appropriately underneath the bottom of the foot can make the gaps between the door and frames of cabinet even.

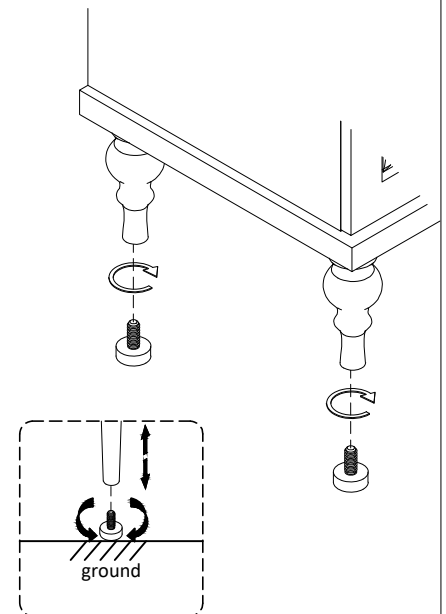
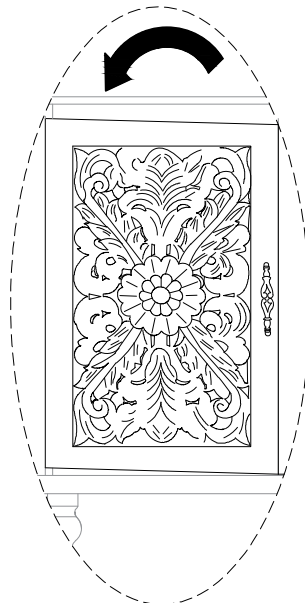
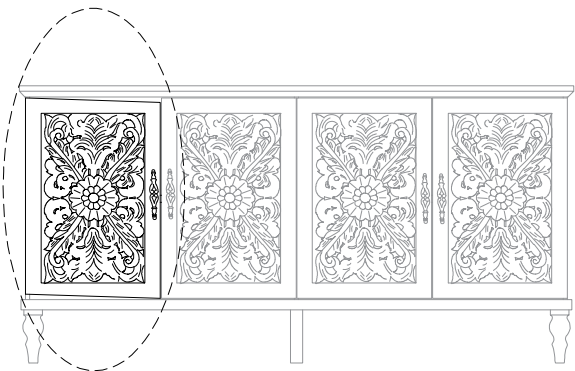

11

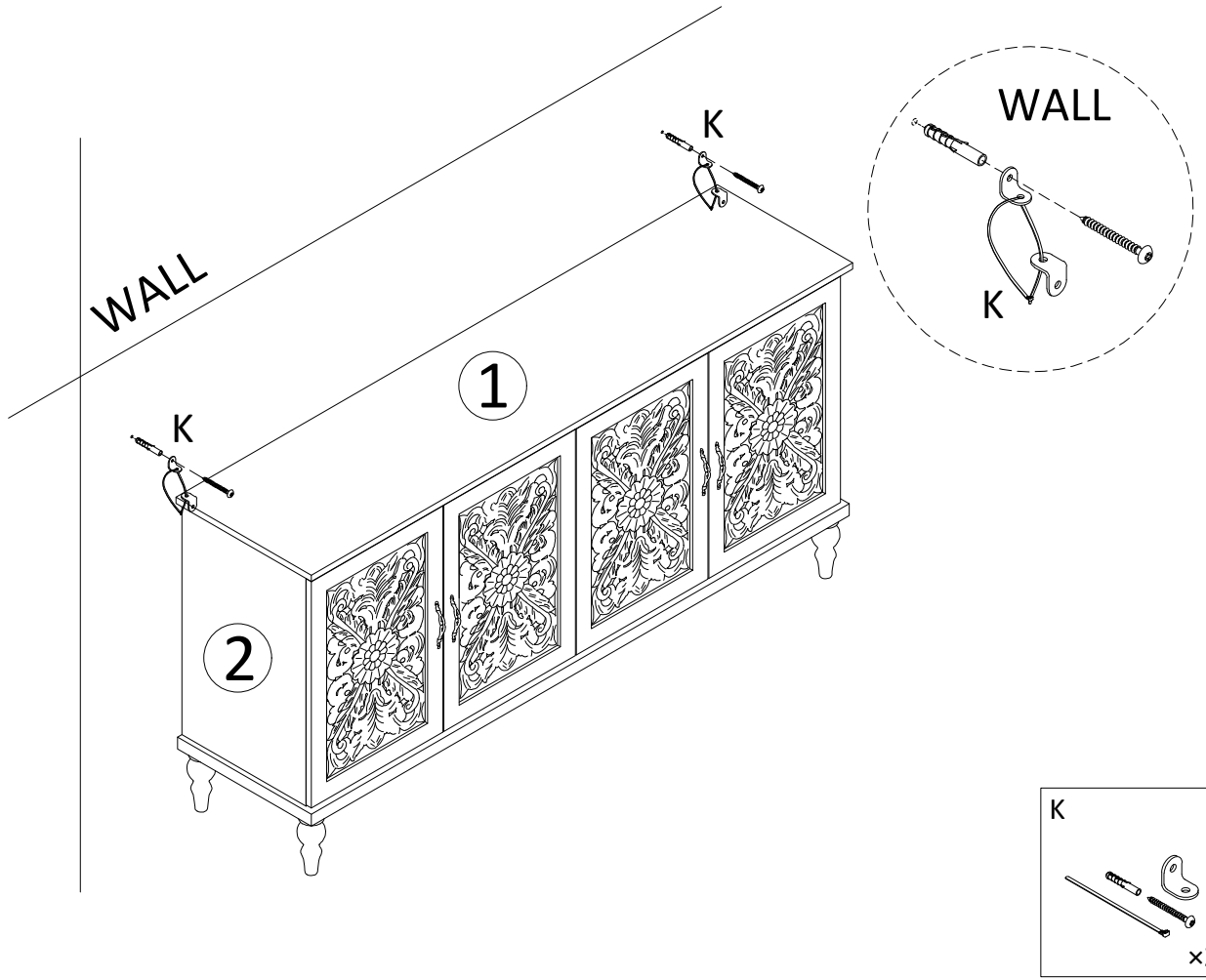

12

