

Assembly Instructions

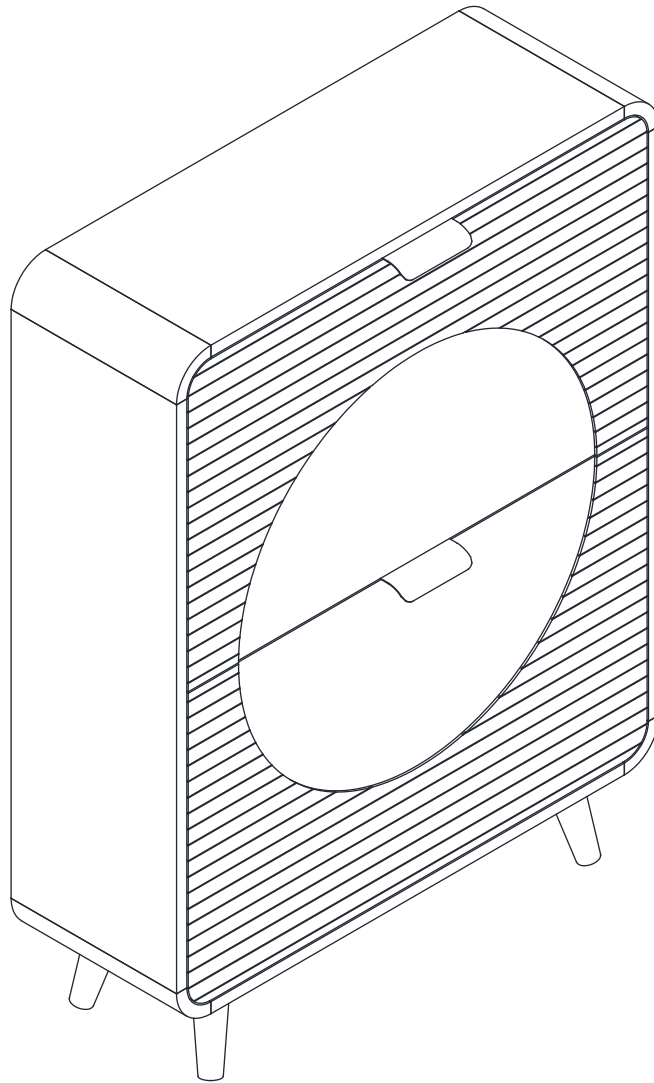

Two-person assembly required





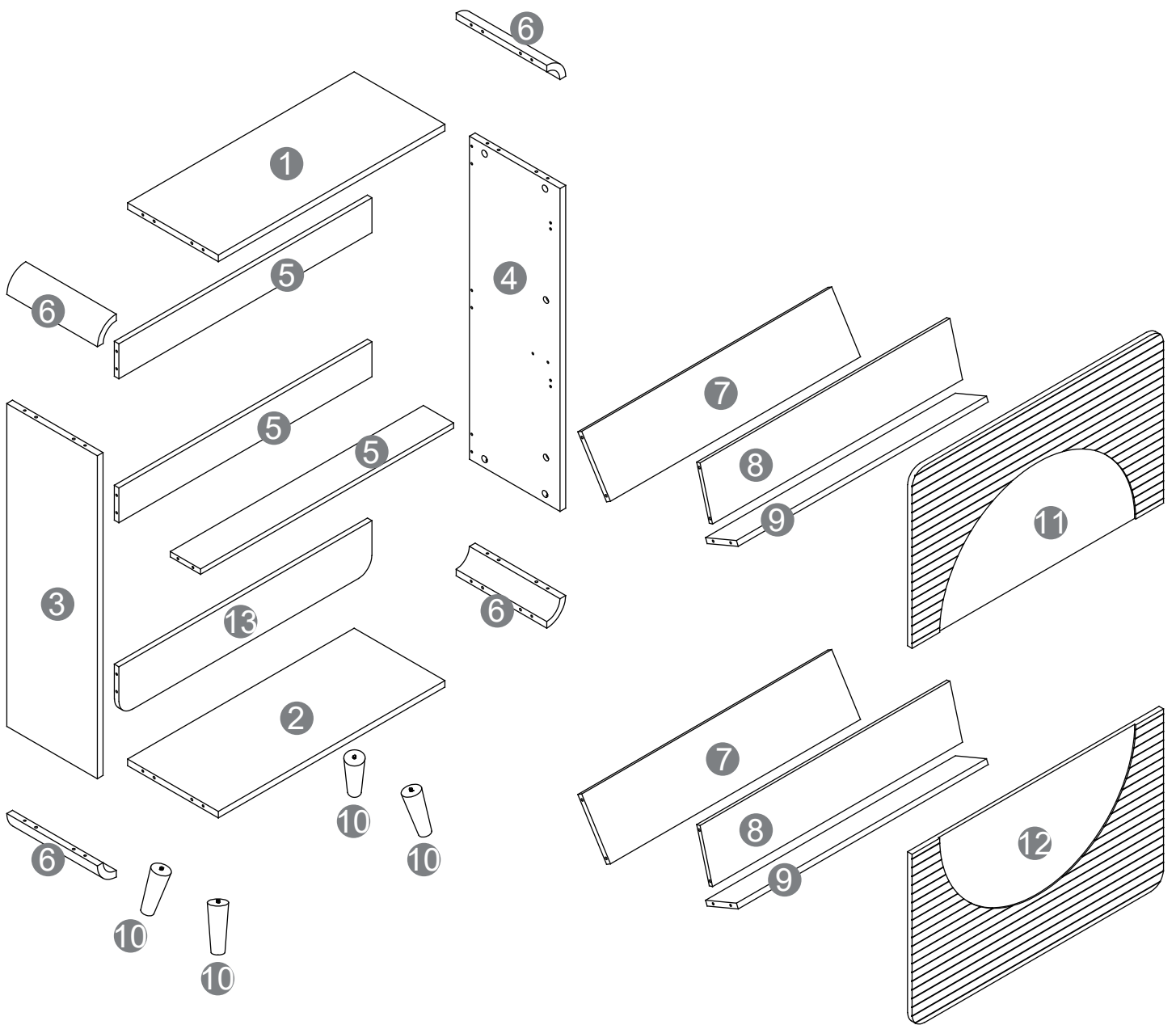

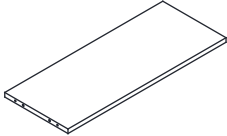
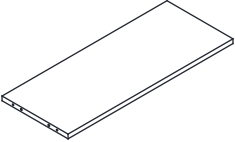

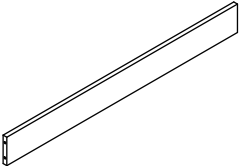
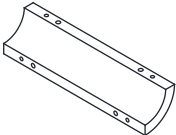
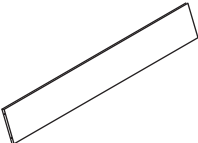

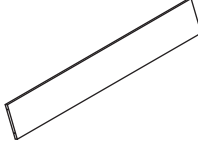
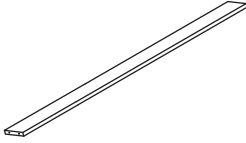

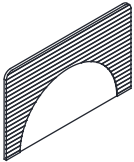
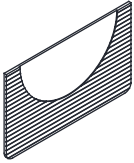
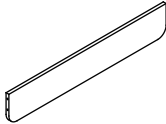

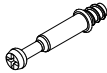
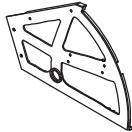

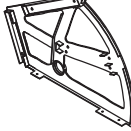

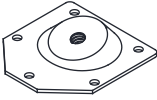

If you have any questions, please contact us

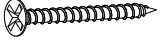
We will help you within 24 hours

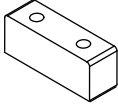

| Item no. | Reference Image | Qty. |
|----------|---|------|
| 1 |  | X1 |
| 2 |  | X1 |
| 3 |  | X1 |
| 4 |  | X1 |
| 5 |  | X3 |
| 6 |  | X4 |
| 7 |  | X2 |

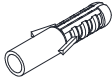
| Item no. | Reference Image | Qty. |
|----------|---|------|
| 8 |  | X2 |
| 9 |  | X2 |
| 10 |  | X4 |
| 11 |  | X1 |
| 12 |  | X1 |
| 13 |  | X1 |

| Item no. | Reference Image | Qty. | Item no. | Reference Image | Qty. |
|----------|--|------|----------|--|------|
| (A) |  M6*35mm | X32 | (J) |  | X2 |
| (B) |  φ15*10mm | X32 | (K) |  | X2 |
| (C) |  φ8*30mm | X16 | (L) |  | X4 |
| (D) |  M3*10mm | X12 | (M) |  M3*16mm | X8 |
| (E) |  M3*14mm | X24 | (N) |  M4*35mm | X2 |
| (F) |  M4*10mm | X24 | (O) |  M3.5*10mm | X4 |
| (G) |  | X4 | (P) |  | X2 |
| (H) |  | X2 | (Q) |  | X4 |
| (I) |  | X2 | (R) |  M4*10mm | X4 |

Cam Lock Fastening System

This Cam Lock Fastening System will be used throughout the assembly process

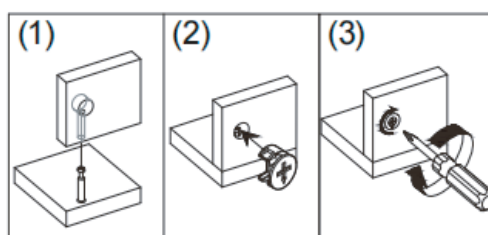

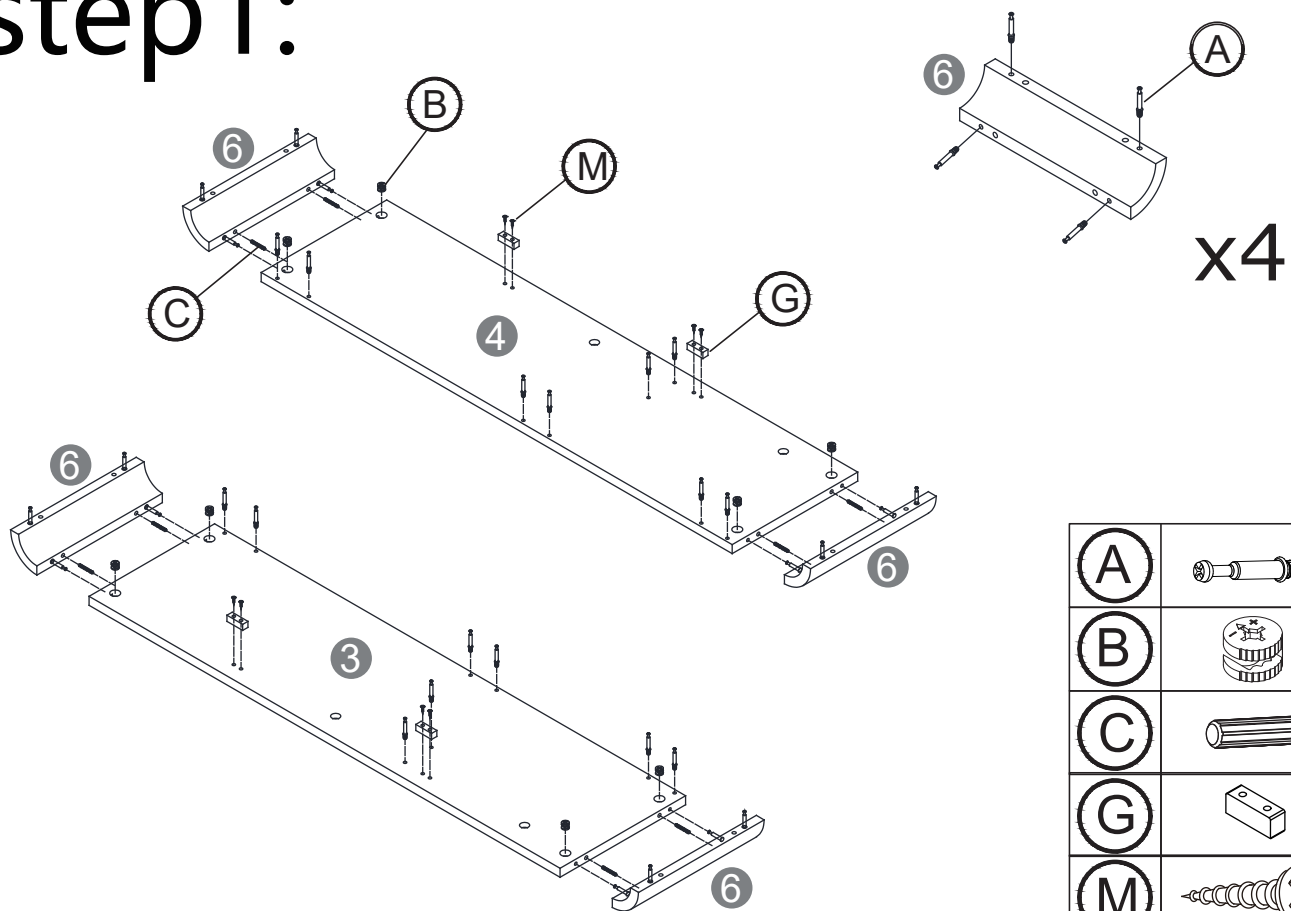

step1:



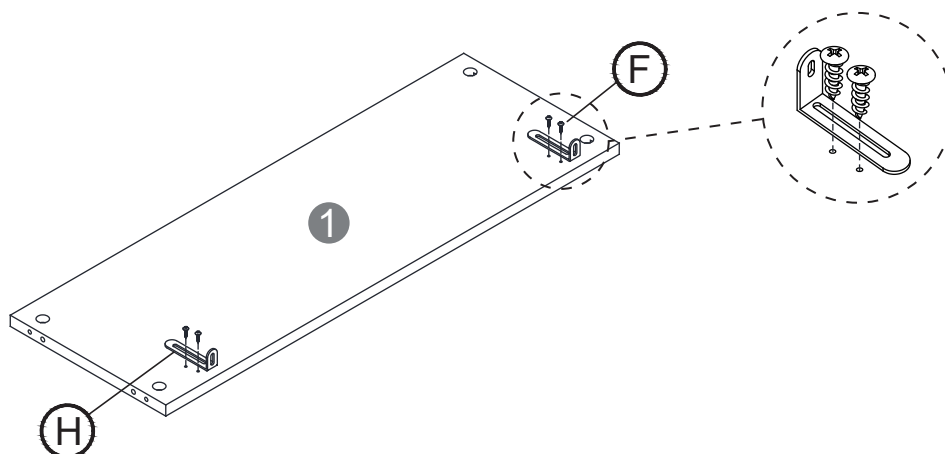

step2:



| | | |
|-----|---|-----|
| (F) |  | X 4 |
| (H) |  | X 2 |

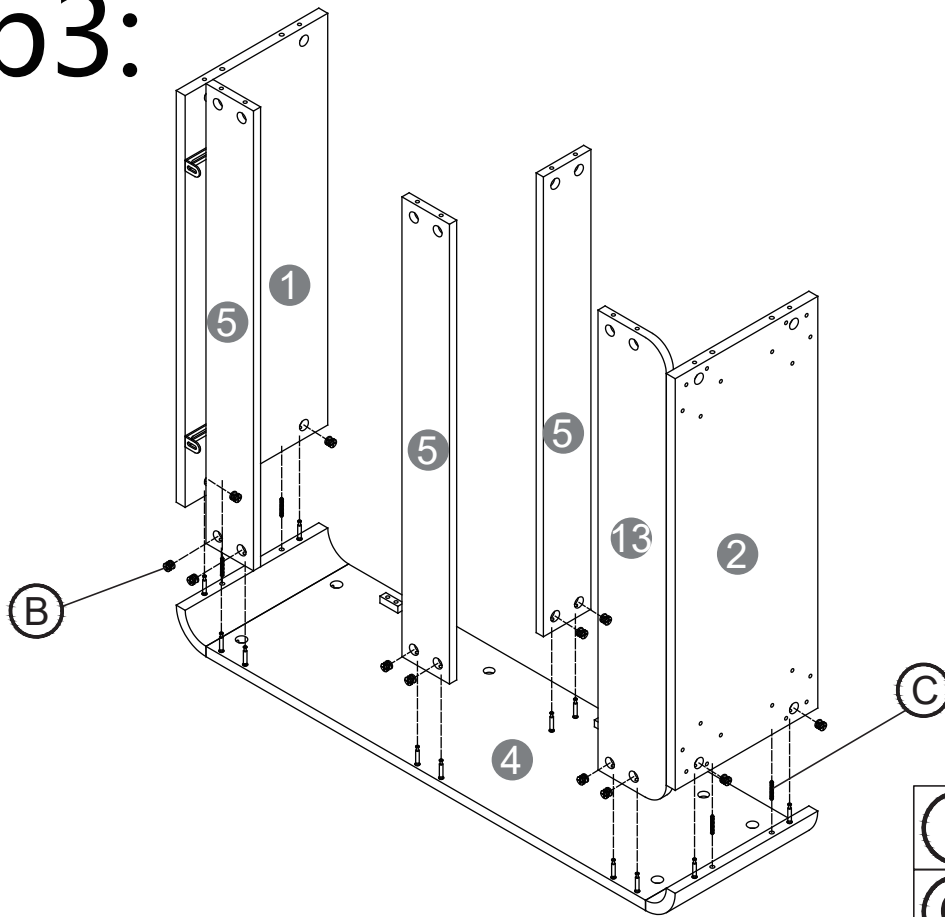

step3:

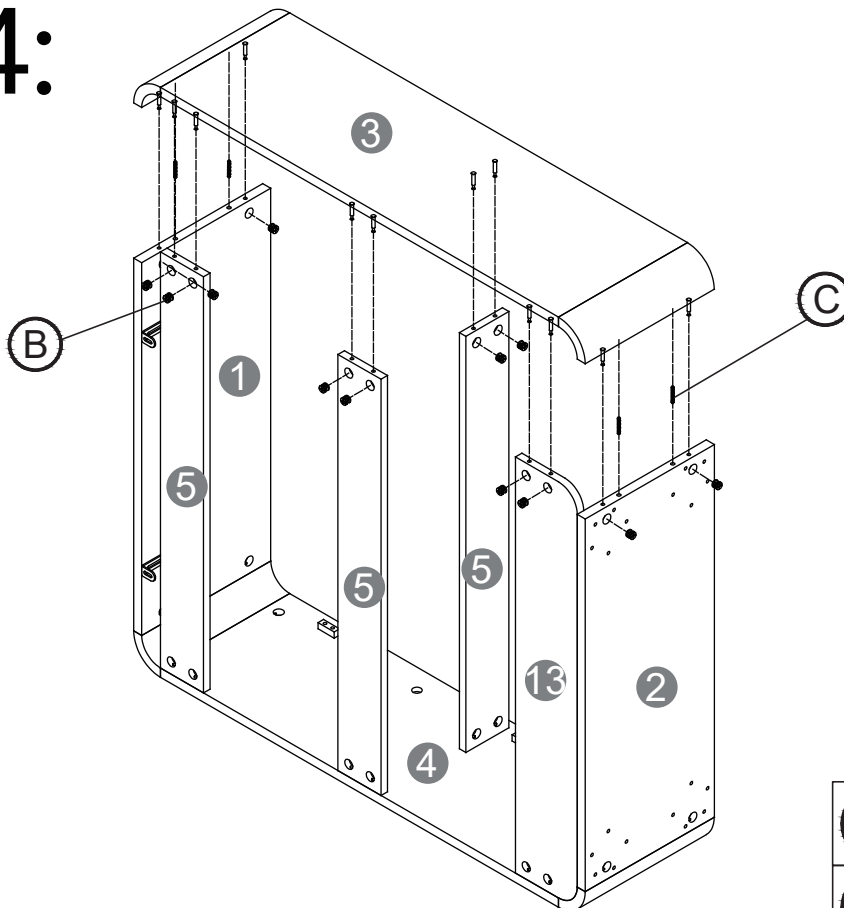

| | | |
|-----|---|------|
| (B) |  | X 12 |
| (C) |  | X 4 |

step4:



| | | |
|-----|---|------|
| (B) |  | X 12 |
| (C) |  | X 4 |

step 5:

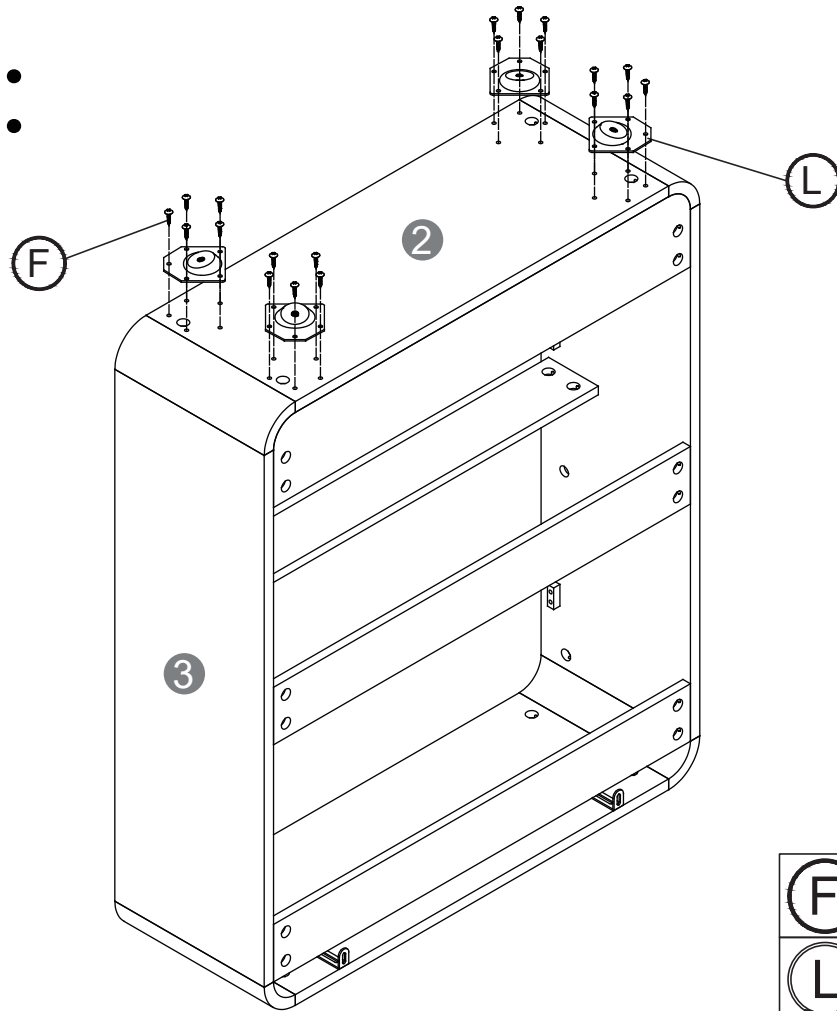

step 6:

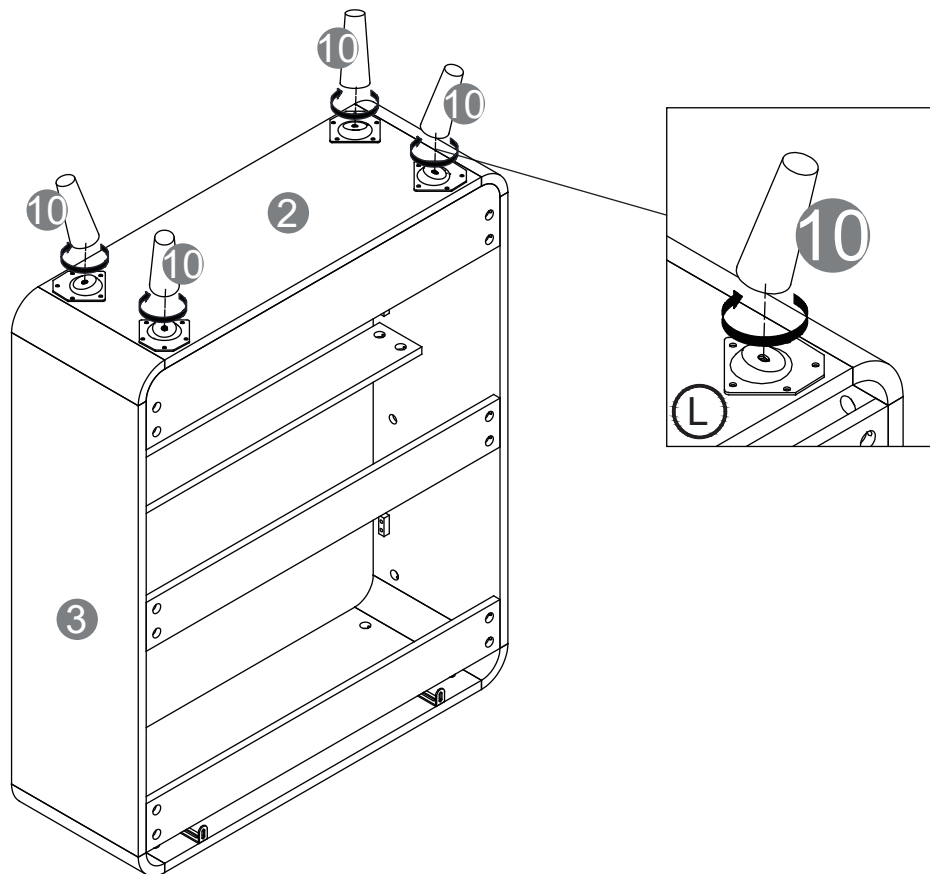



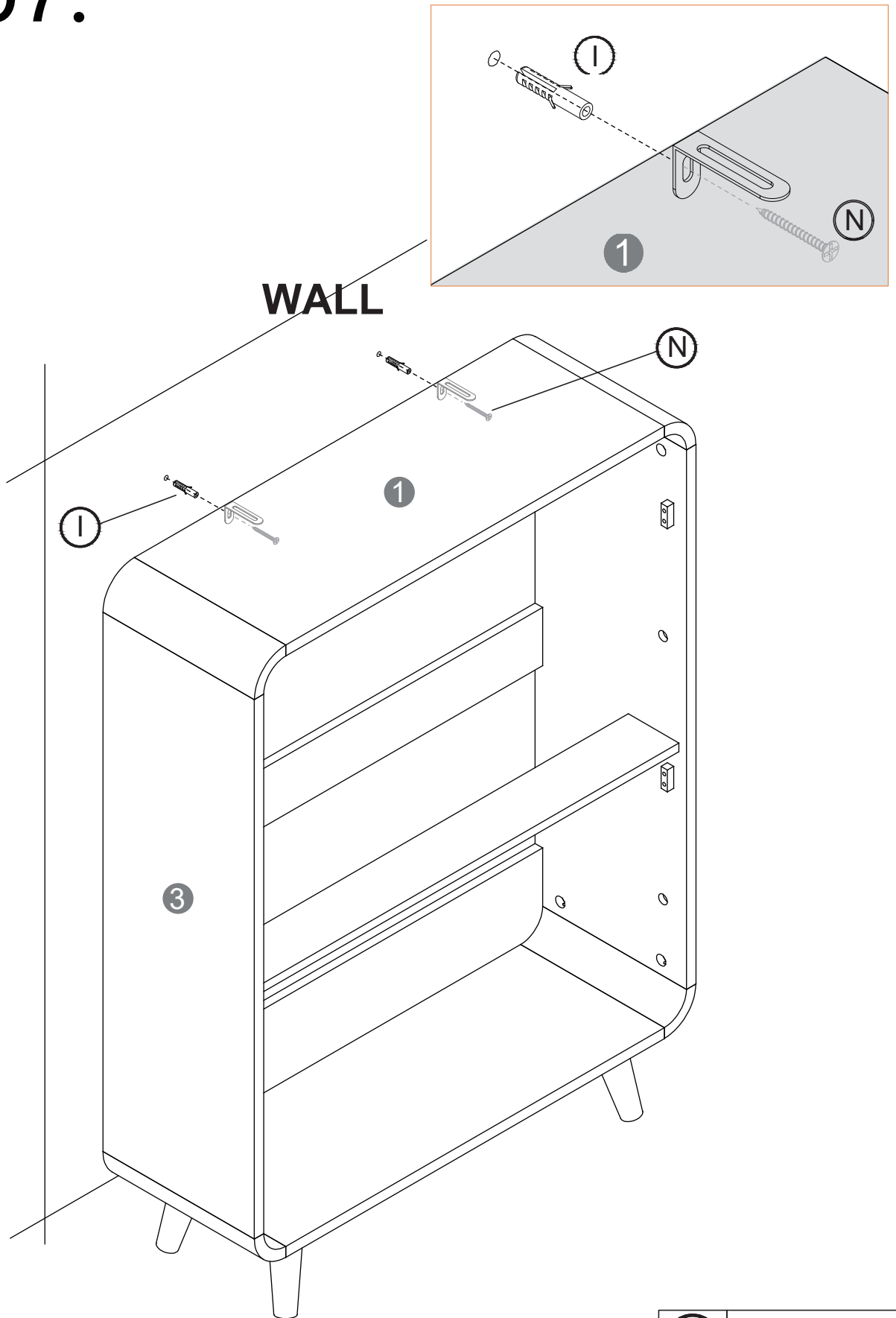

step 7:

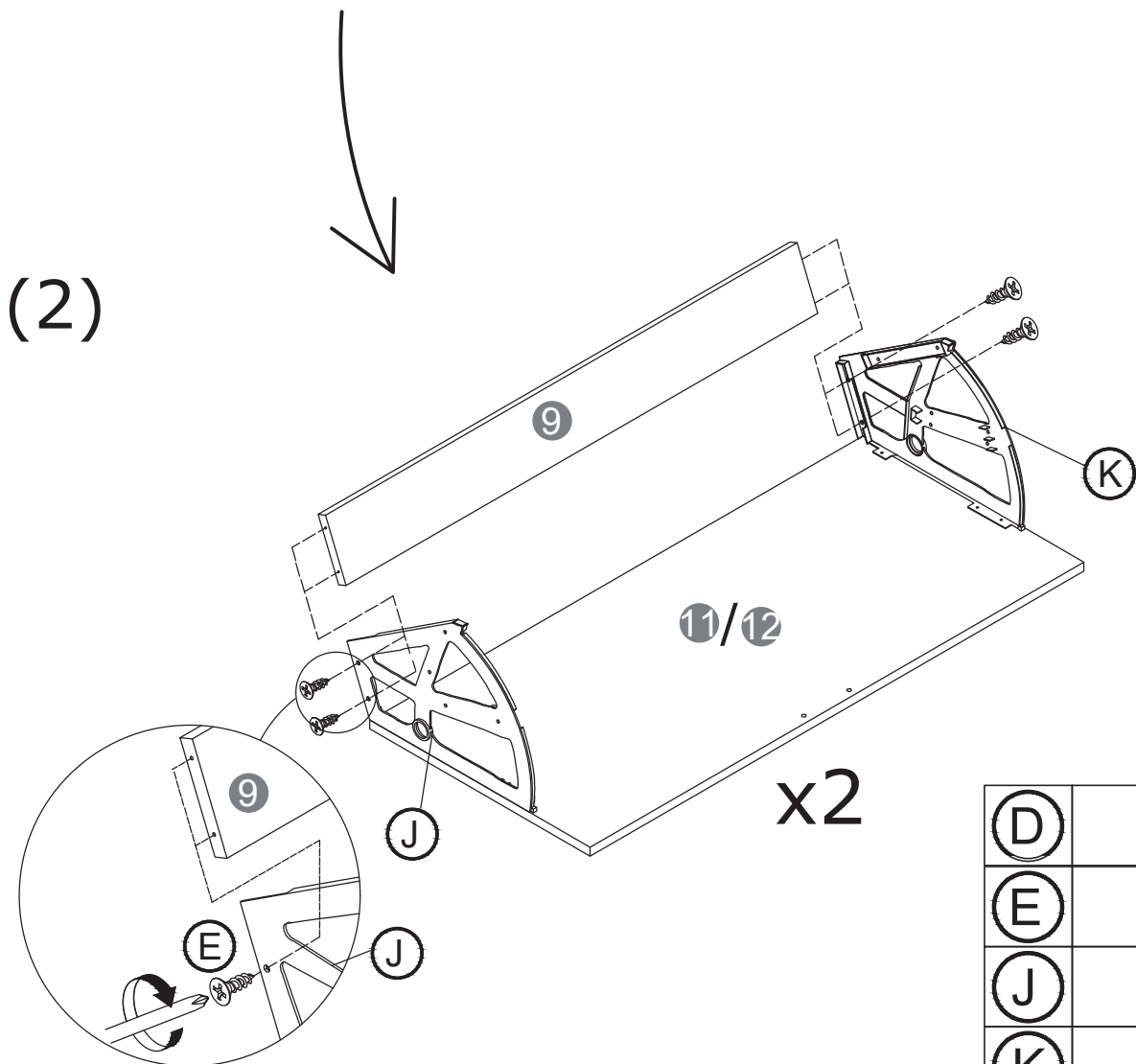
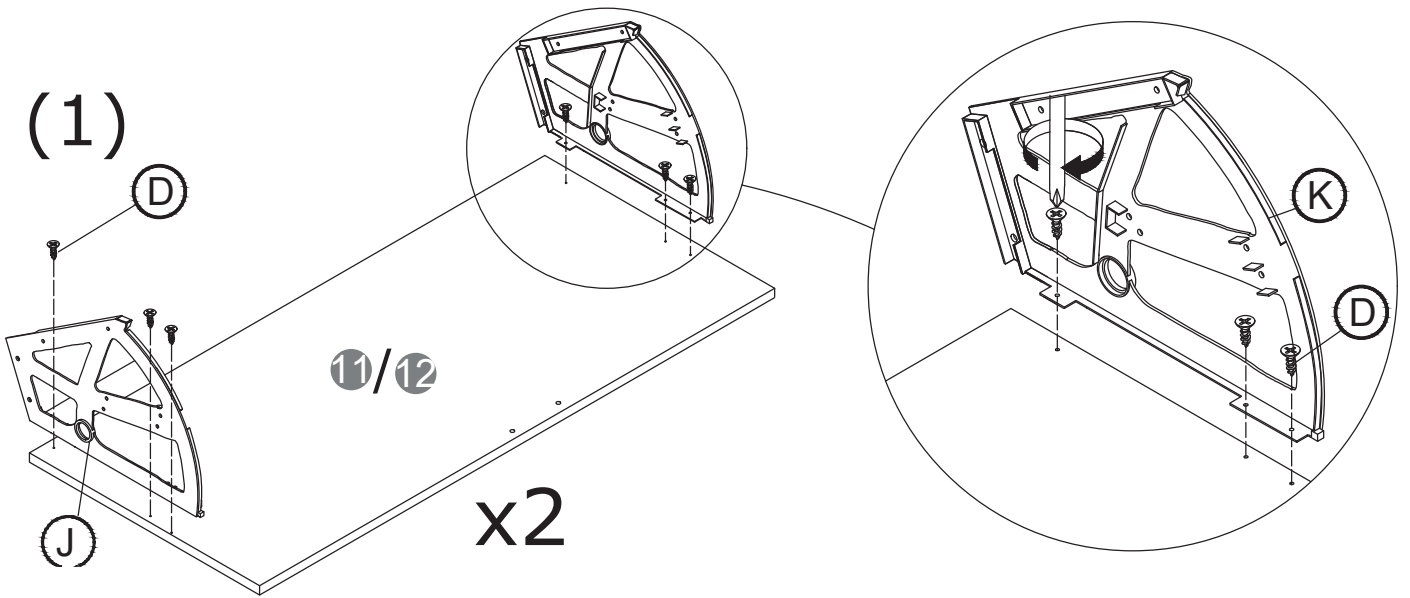

| | | |
|---|--|-----|
| I | | X 2 |
| N | | X 2 |

step 8:



| | | |
|---|---|------|
| D |  | X 12 |
| E |  | X 8 |
| J |  | X 2 |
| K |  | X 2 |

step9:

(1)

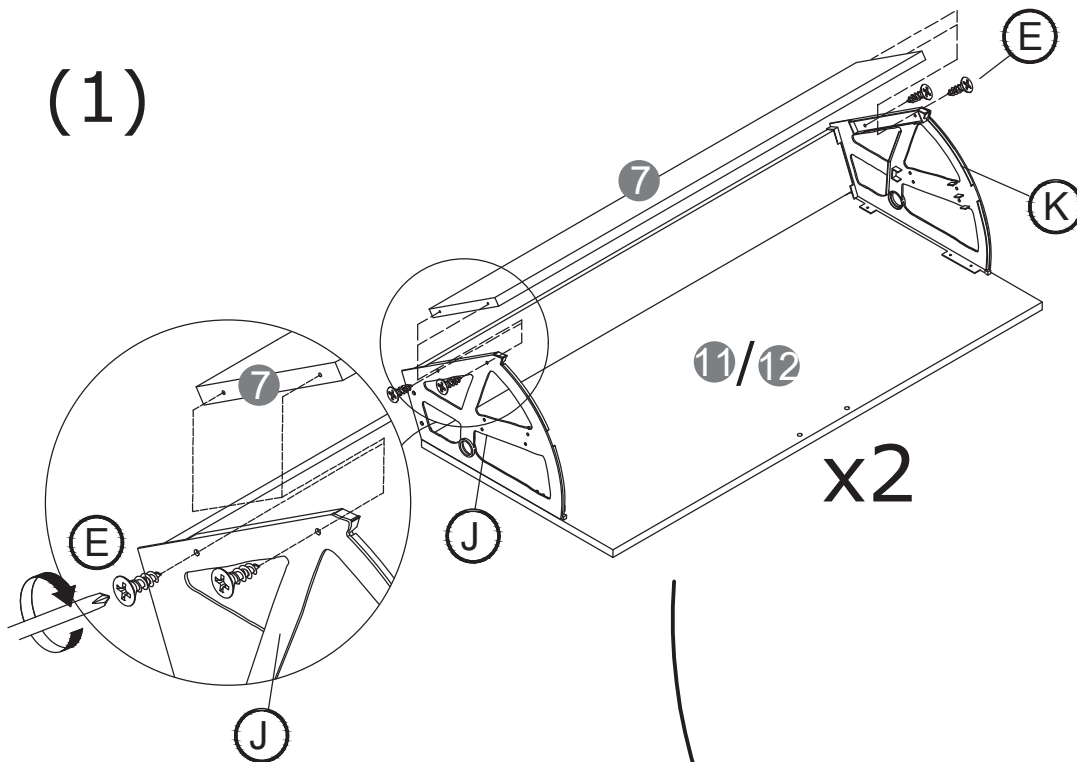



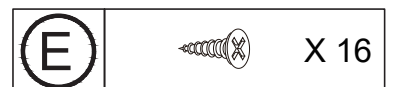
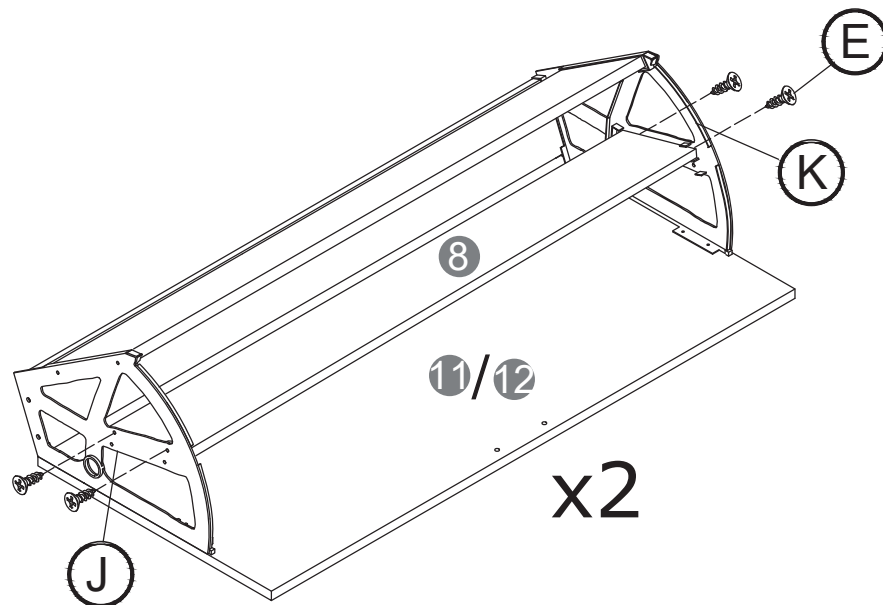

(2)

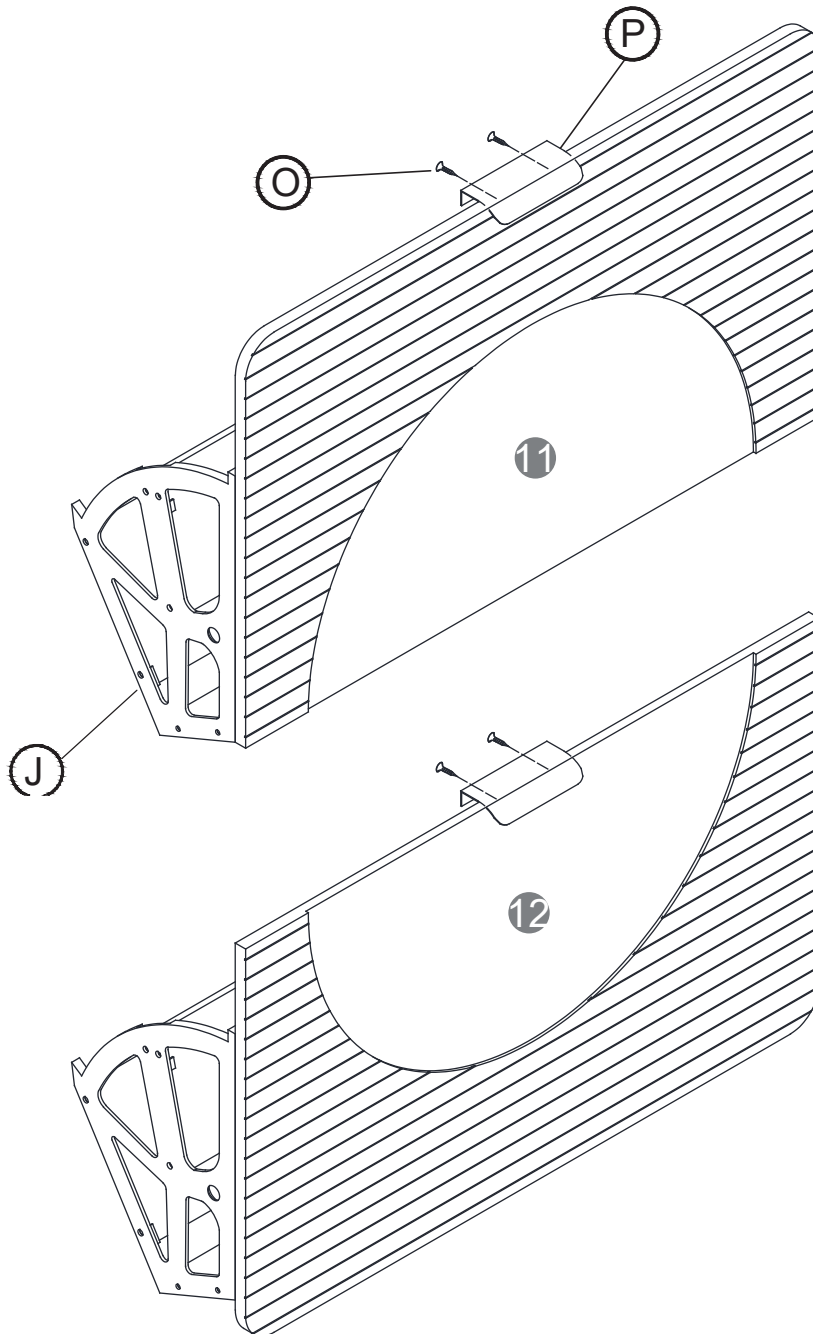





step 10:

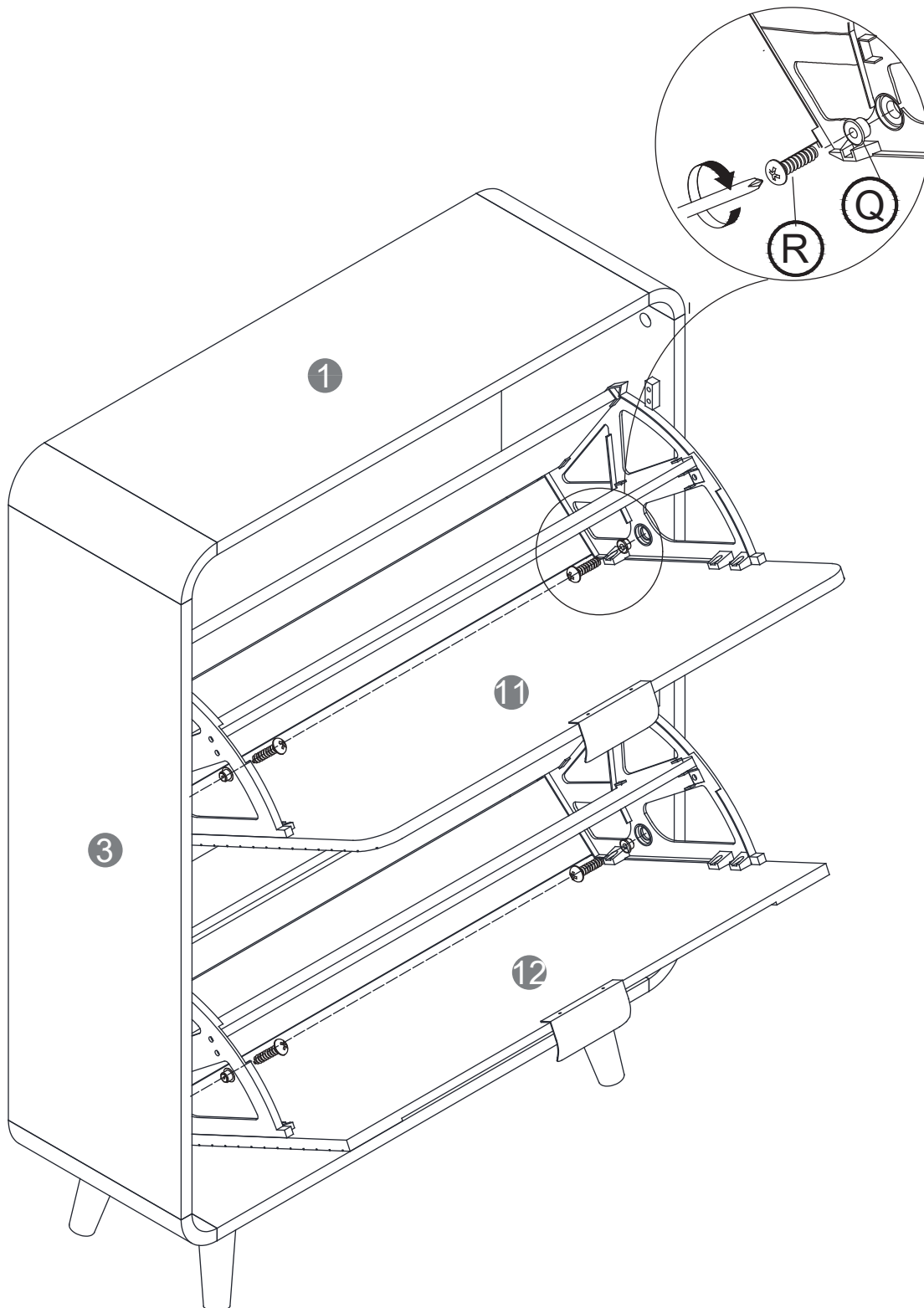

| | |
|---|---|
|  |  X 4 |
|  |  X 2 |

step 11:



| | | |
|---|---|-----|
|  |  | X 4 |
|  |  | X 4 |