

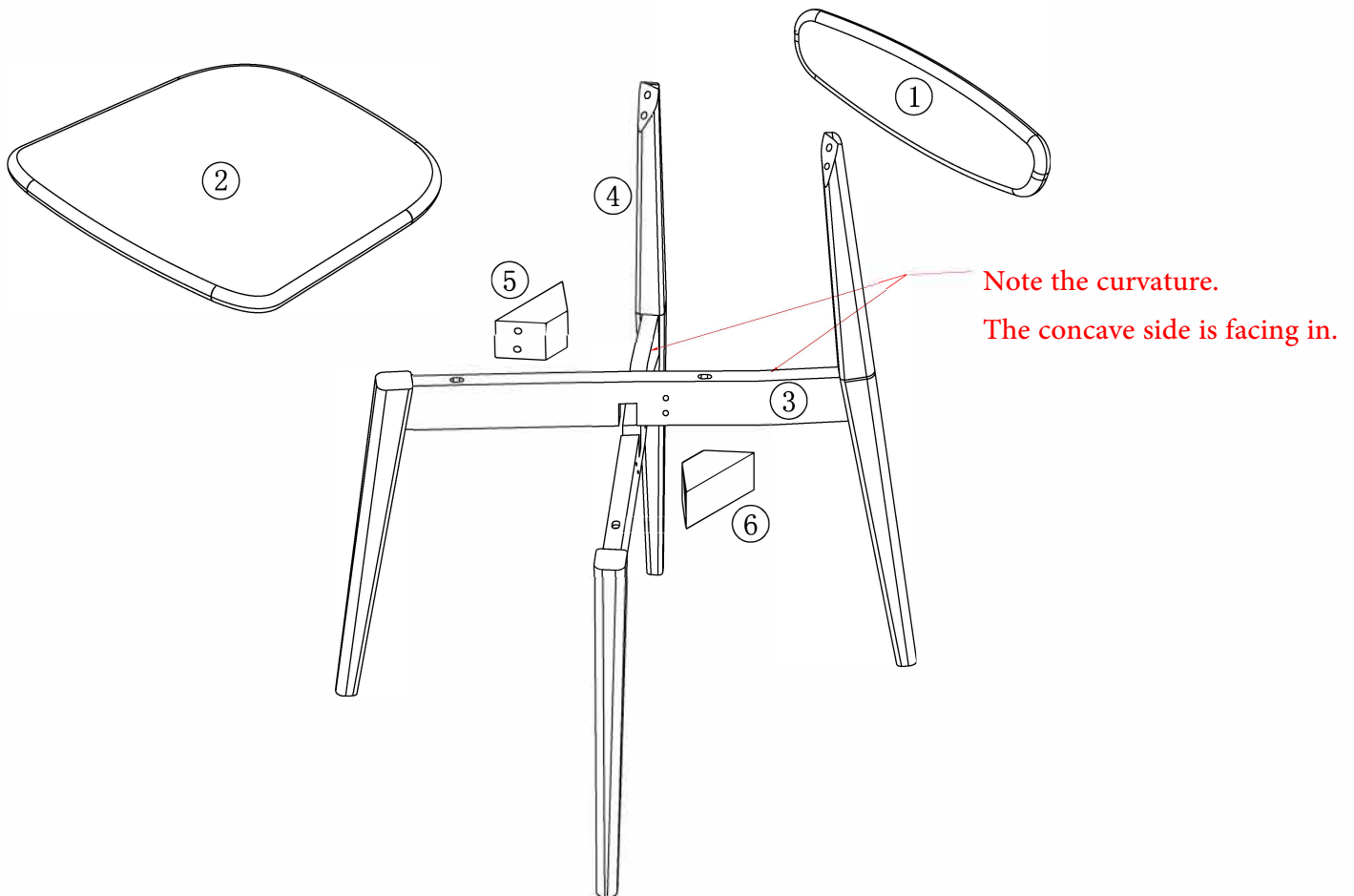

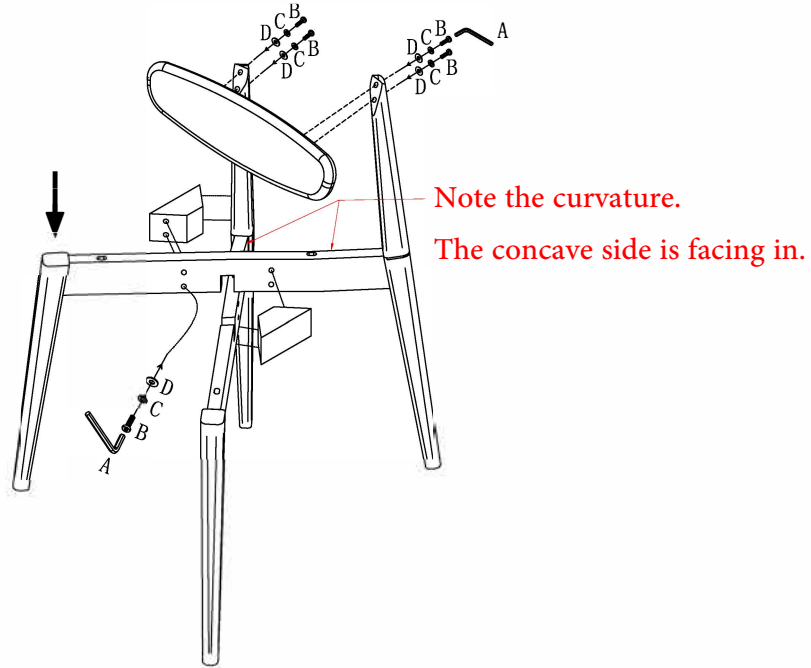

Chairs Assembly Instructions

If any parts are missing or encounter any problems, please find us on Amazon "Contact Seller" or email: amzservice@yeswood.com with some photos to better offer you help.



Step 1: the leg frame notch up and down into the group, the backrest is assembled first, in the group into the connecting wood, all the screws do not lock (when assembling, pay attention to the curvature of the two leg frames, the concave side of the two legs face inward corresponding to the notch assembly).





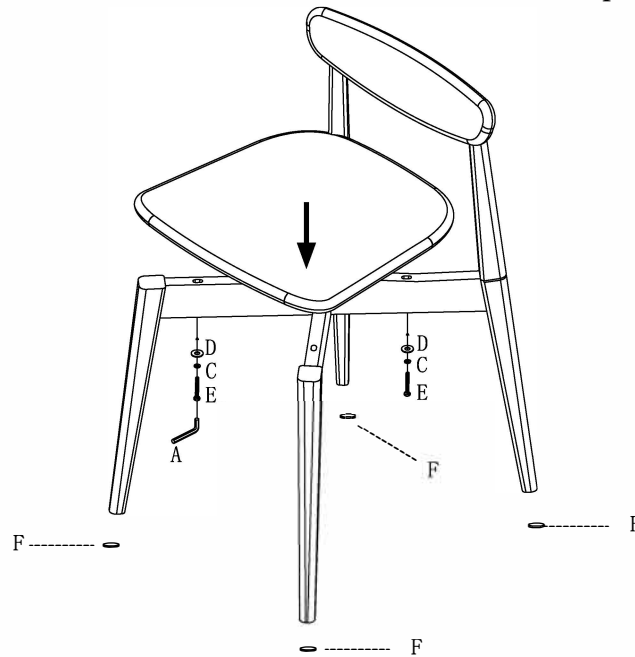

						
A: Allen wrench 4#=1	B: Screw M6*30=12	C: Spring pads $\phi 6=12$	D: Flat pads $\phi 6=12$			

Step 2: Lock the screws on the corresponding holes of the seat plate, don't tighten the screws first, level the chair and then lock all the screws.

Note: After the chair is set up, in case the four feet are not level, stick a flannel pad F on the bottom of the short feet to level the four feet.



Scan for Customer Service

						
A: Allen wrench 4#=1		C: Spring pads $\phi 6=4$	D: Flat pads $\phi 6=4$	E: Screws M6*60=4	F: Fleece pads $\phi 20=6$	