

**23.6" HALL TREE WITH BENCH
AND SHOE STORAGE**

USER MANUAL

1

ASSEMBLY INSTRUCTIONS

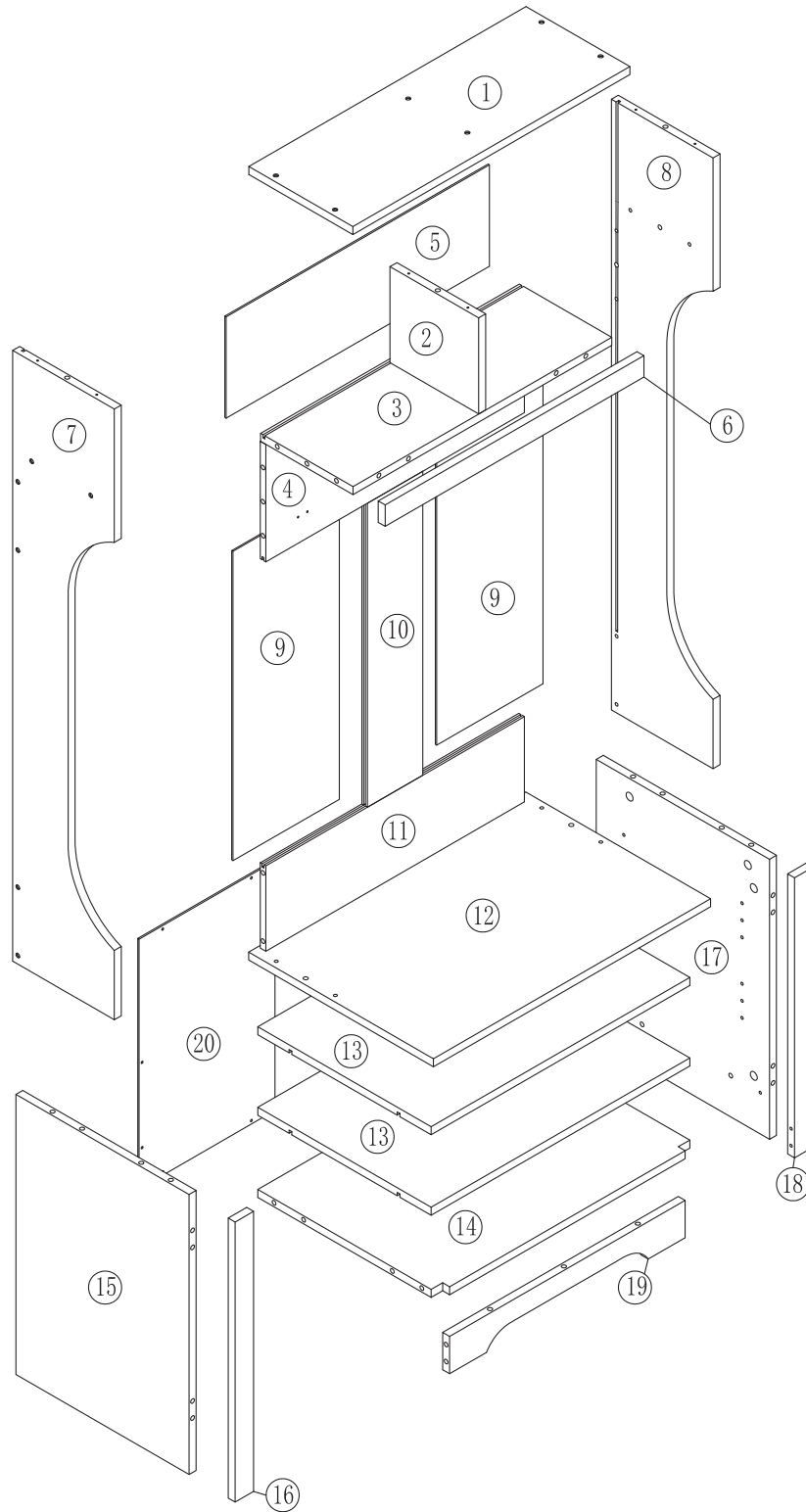

2

PACKAGING LIST

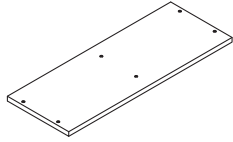

①x1



②x1

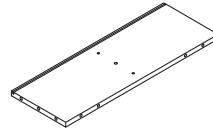

③x1

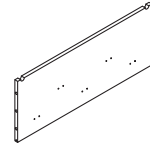

④x1

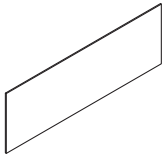

⑤x1

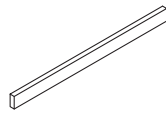

⑥x1



⑦x1



⑧x1



⑨x2



⑩x1



⑪x1

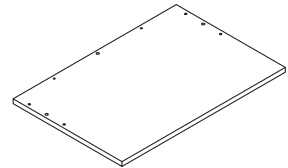

⑫x1

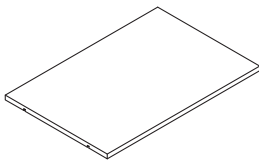

⑬x2

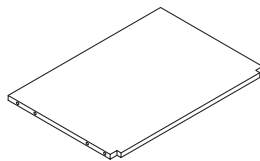

⑭x1

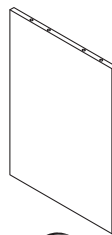

⑮x1



⑯x1

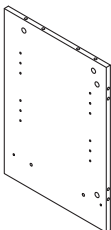

⑰x1



⑱x1

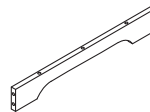

⑲x1

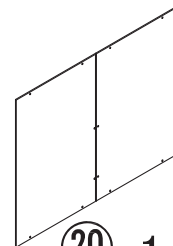

⑳x1

3

PACKAGING LIST

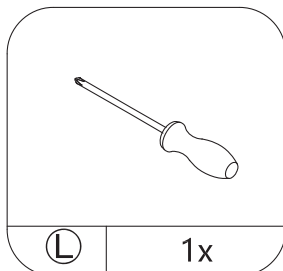
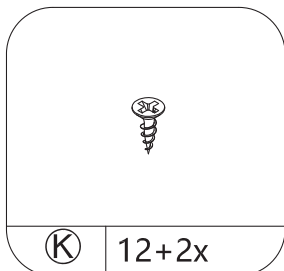
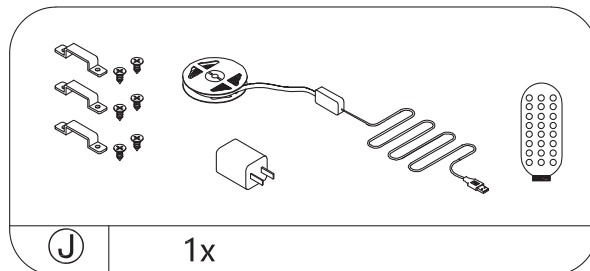
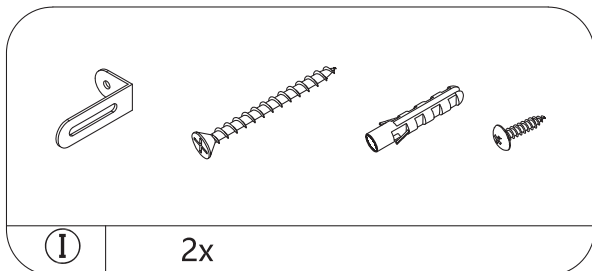
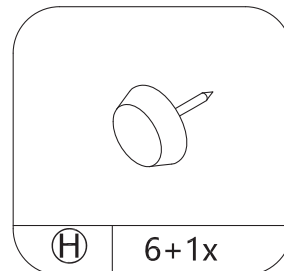
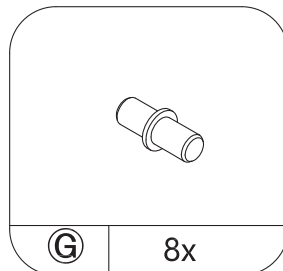
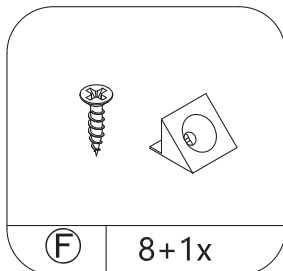
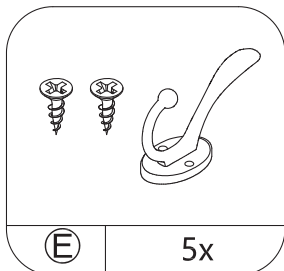
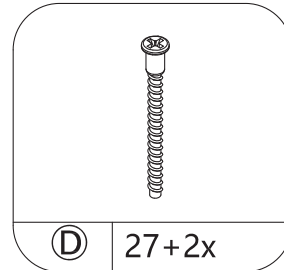
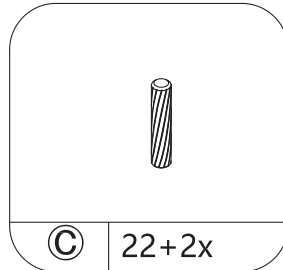
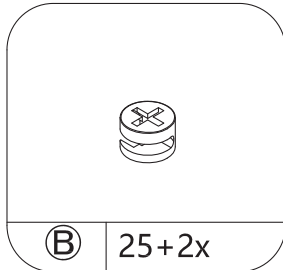
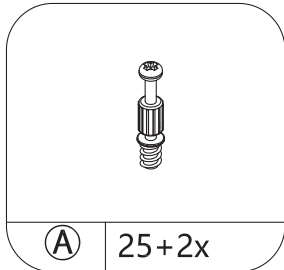

4

STEP 1

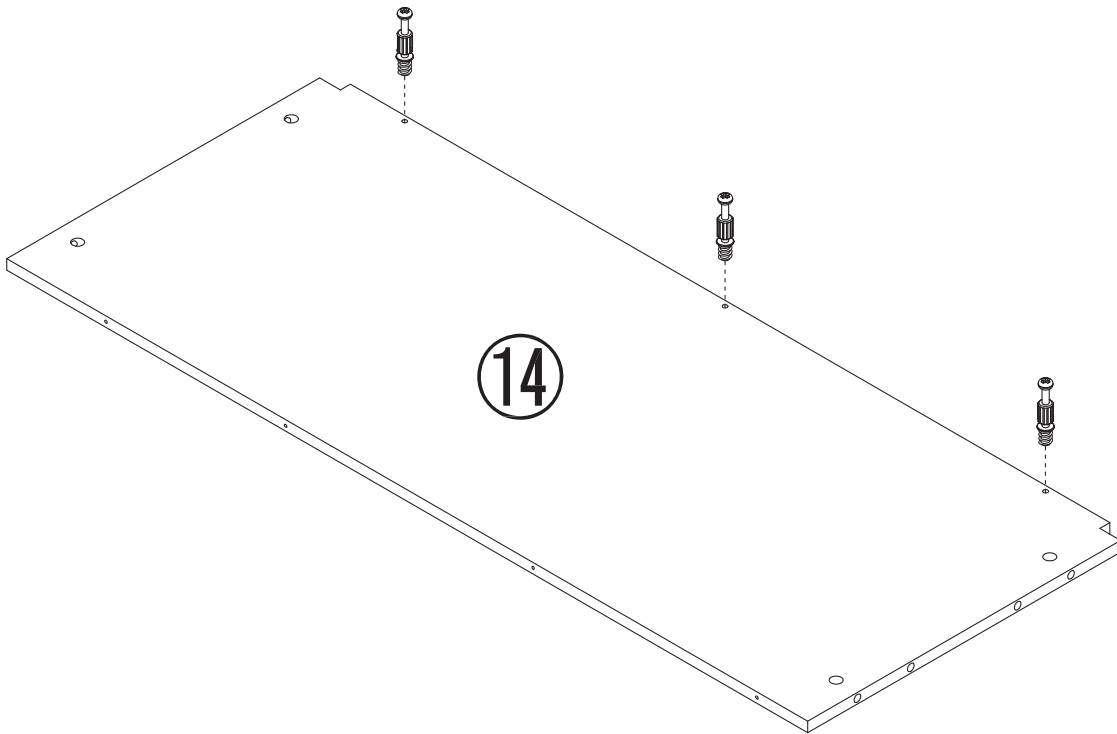
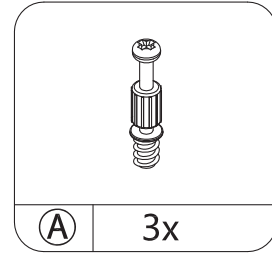

5

STEP 2

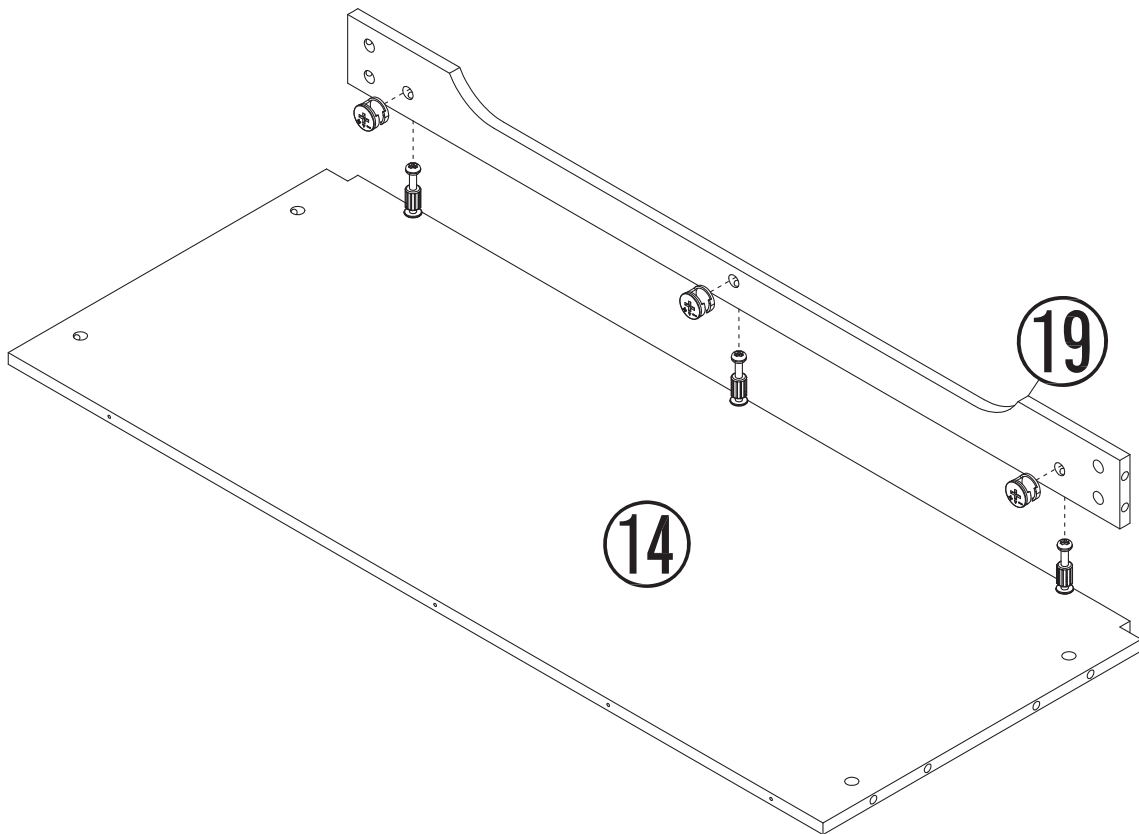
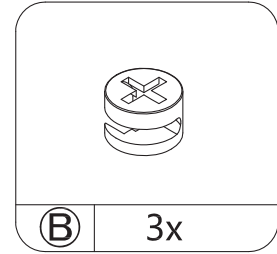

6

STEP 3

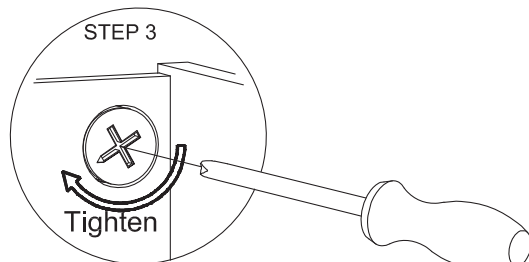
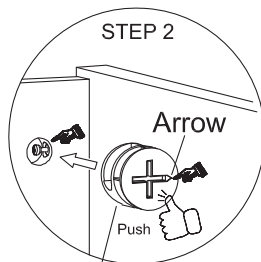
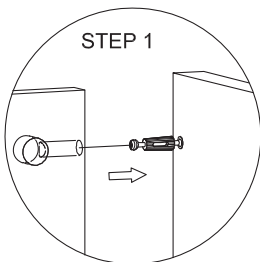
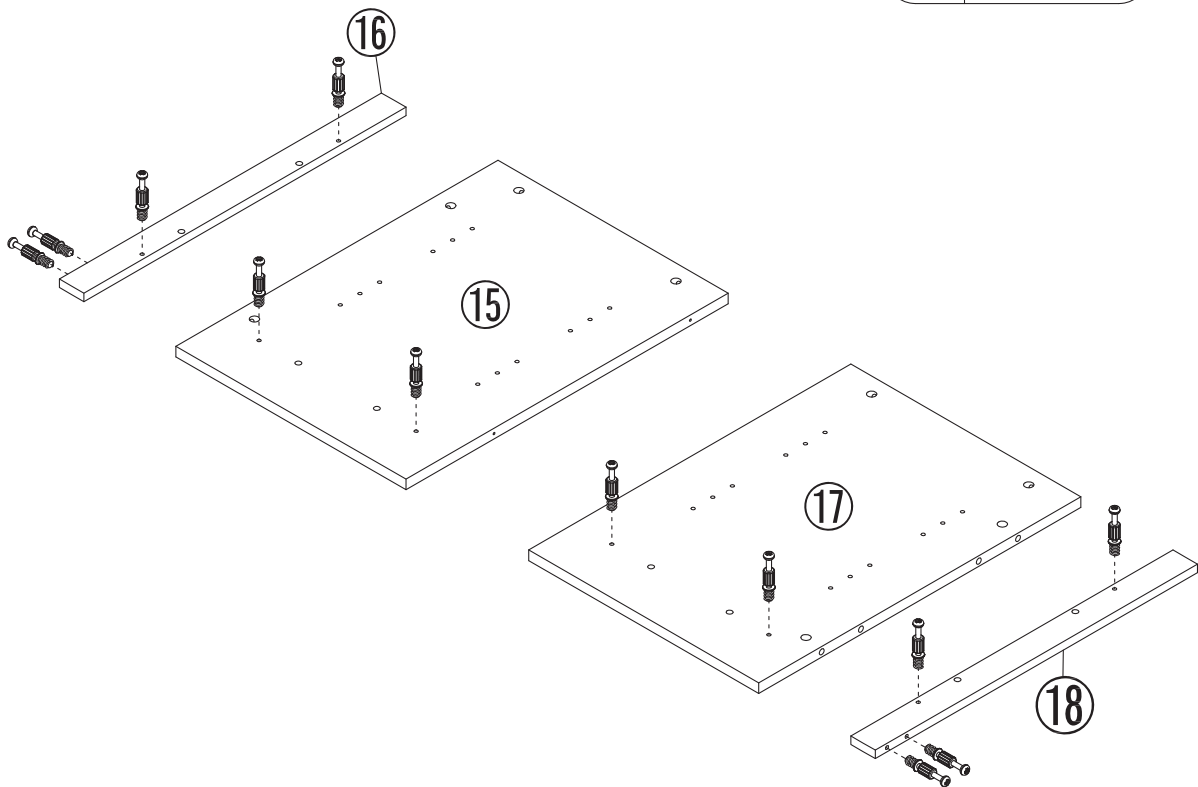
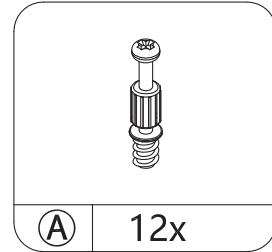

Push the KD cam all the way into the hole before tightening.

7

STEP 4

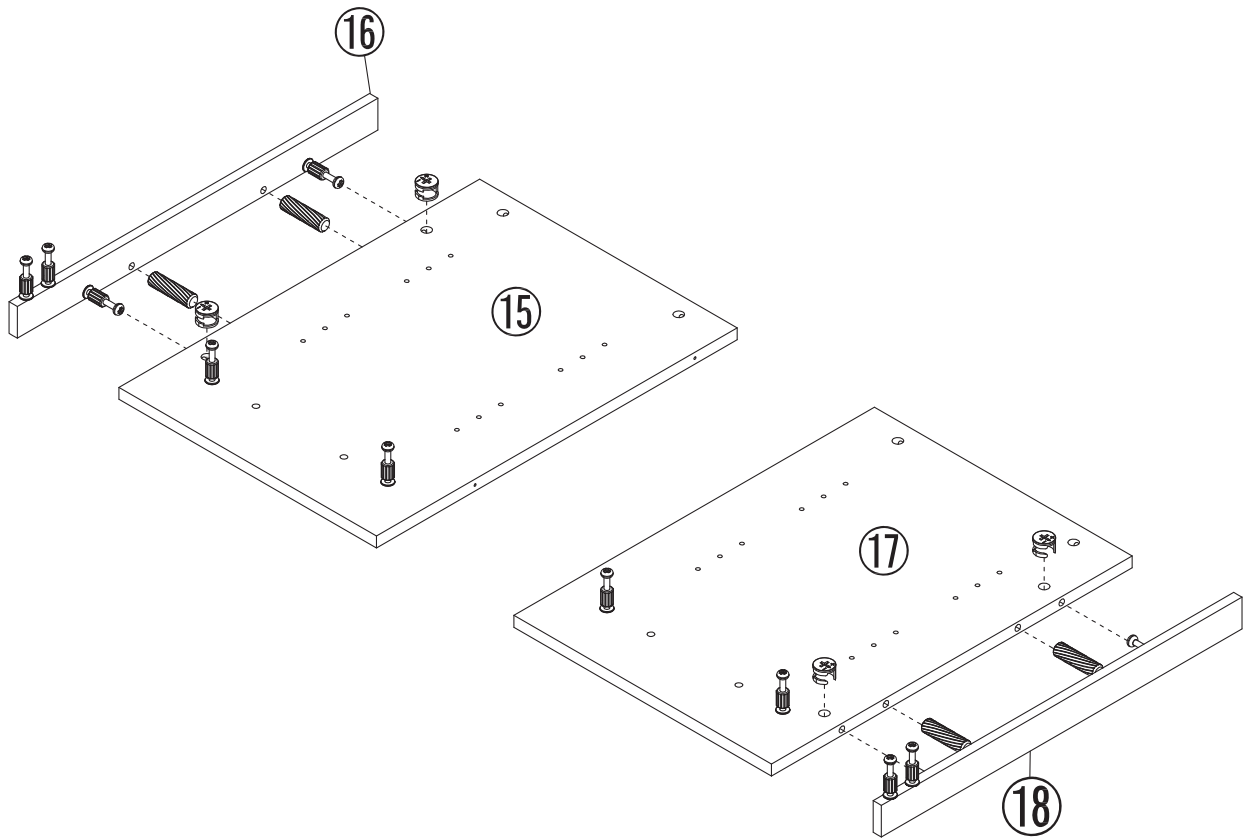
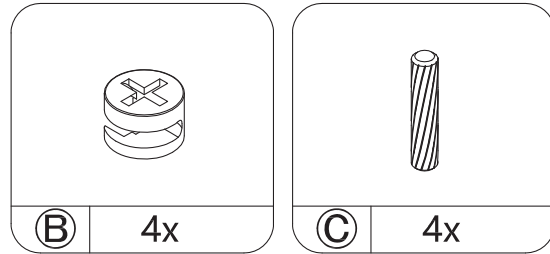

8

STEP 5

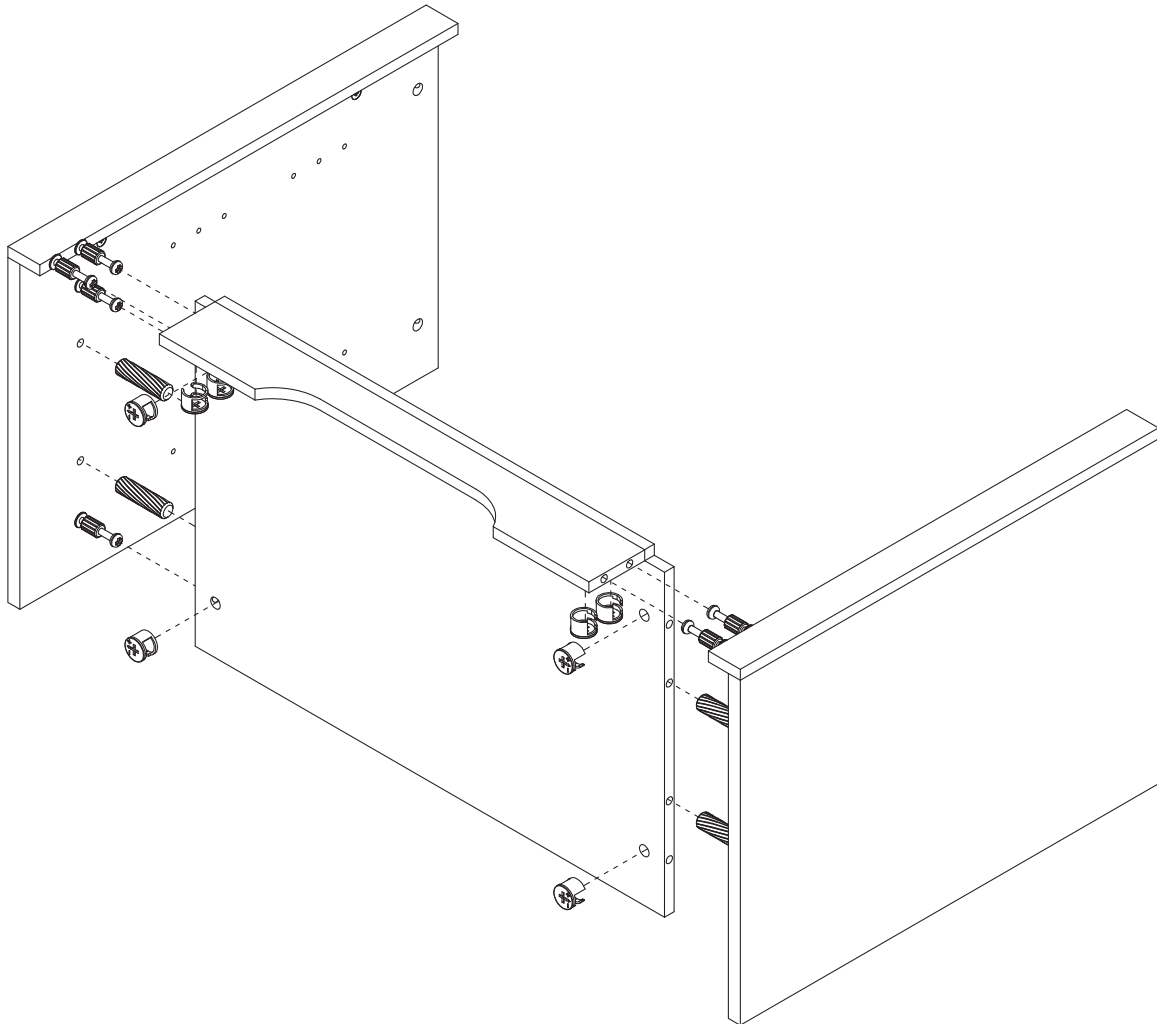
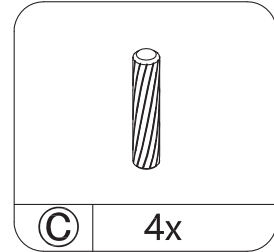
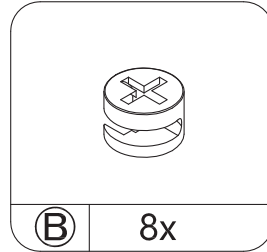

9

STEP 6

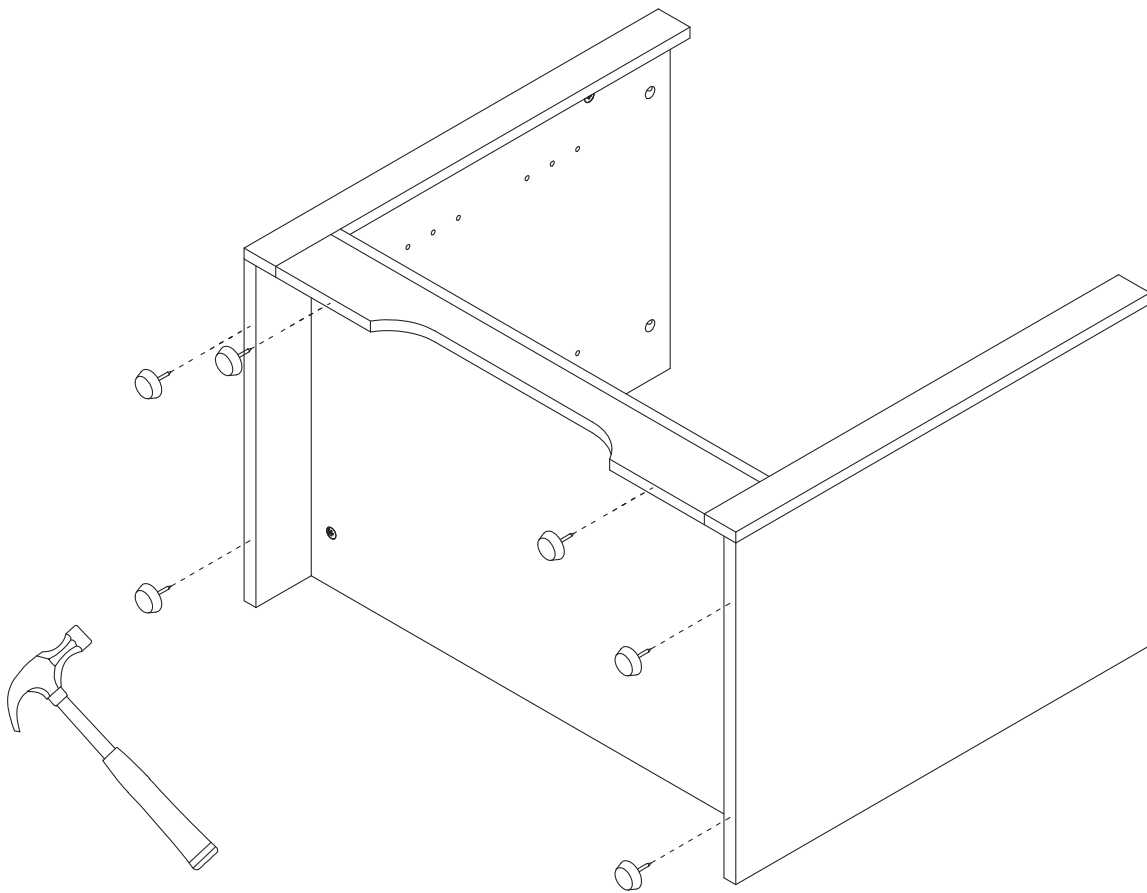
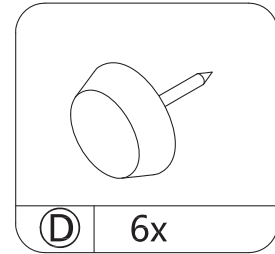

STEP 7

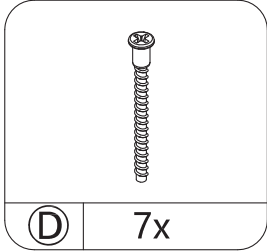
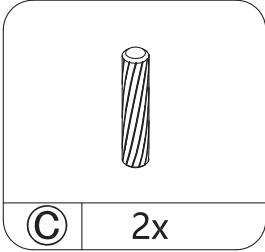

STEP 1

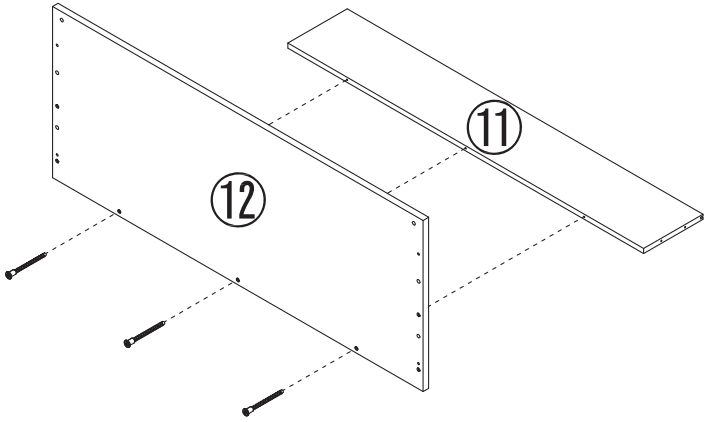

STEP 2

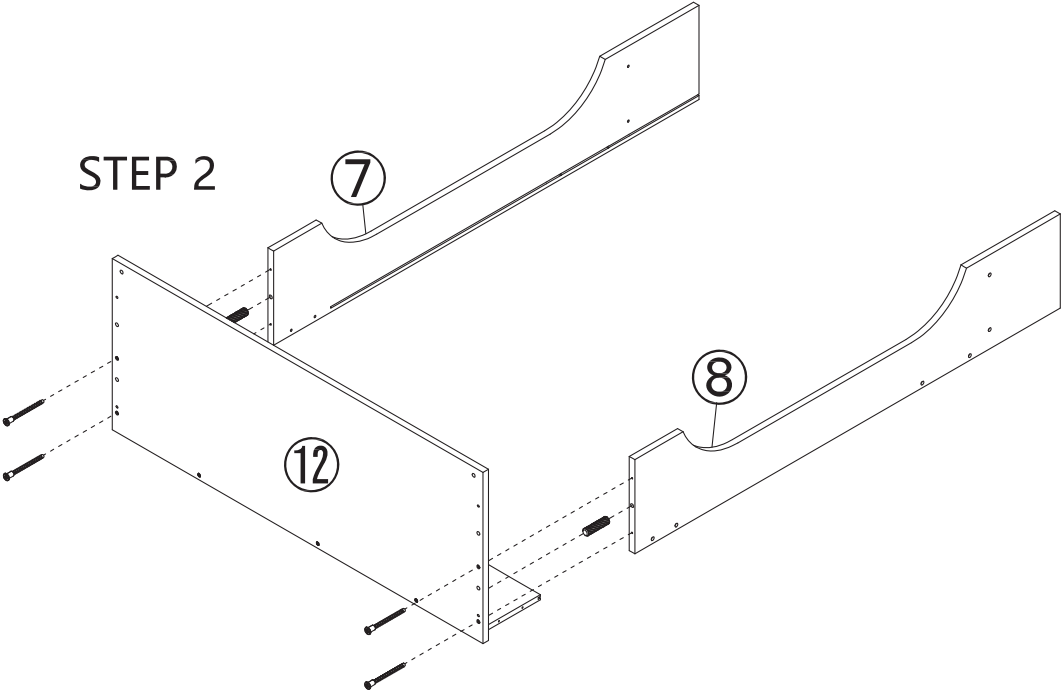

STEP 8

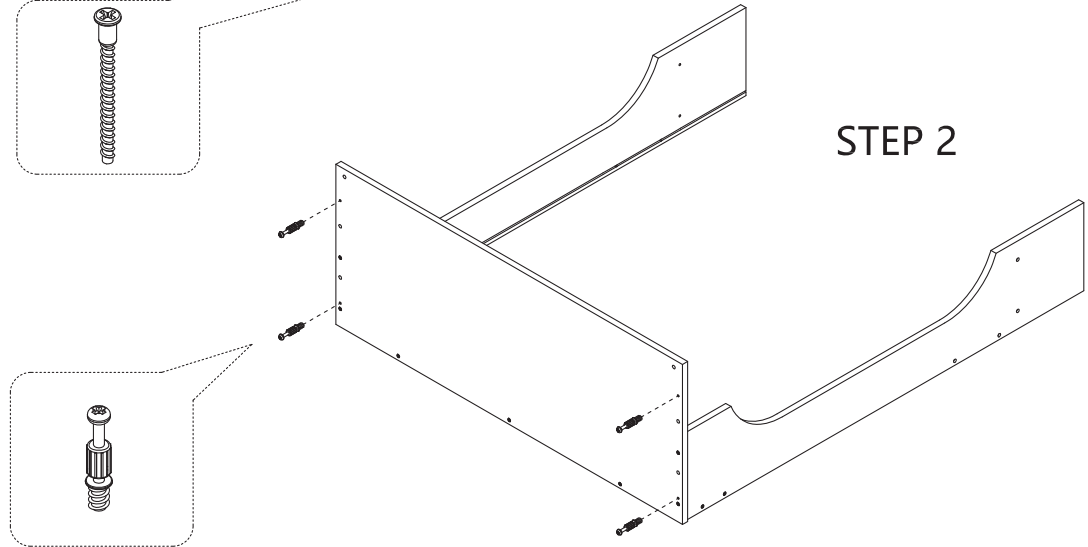
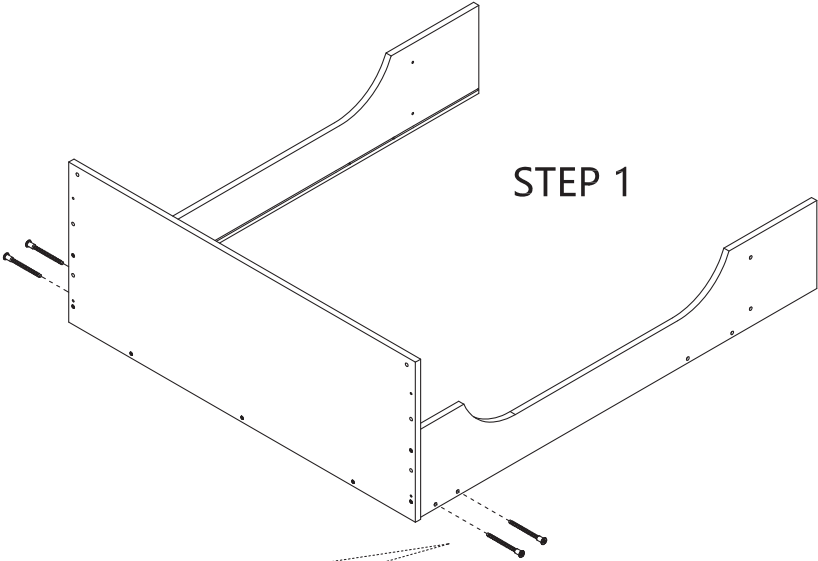
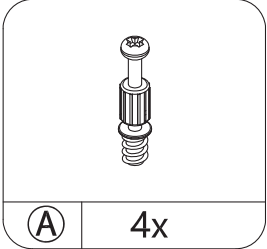
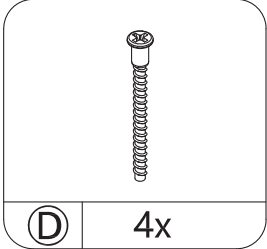

12

STEP 9

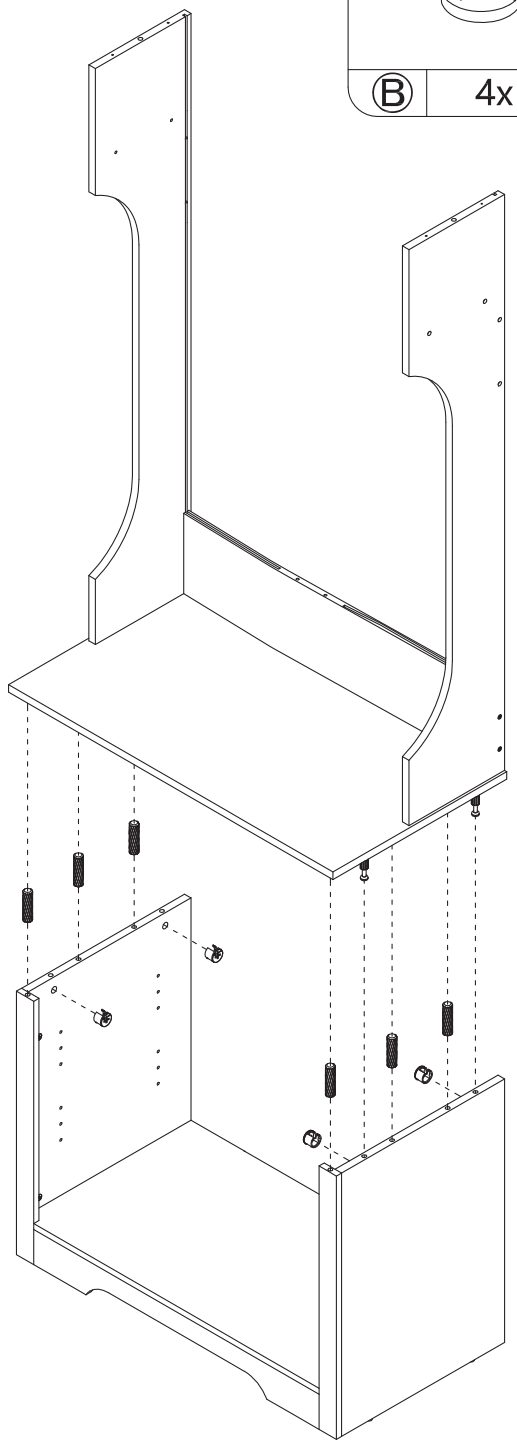
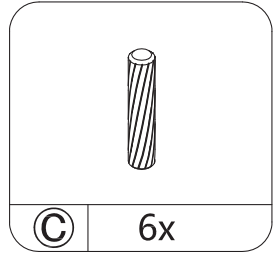
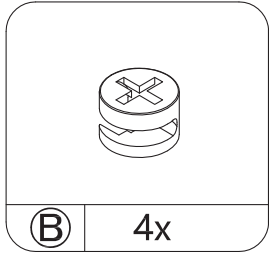

13

STEP 10

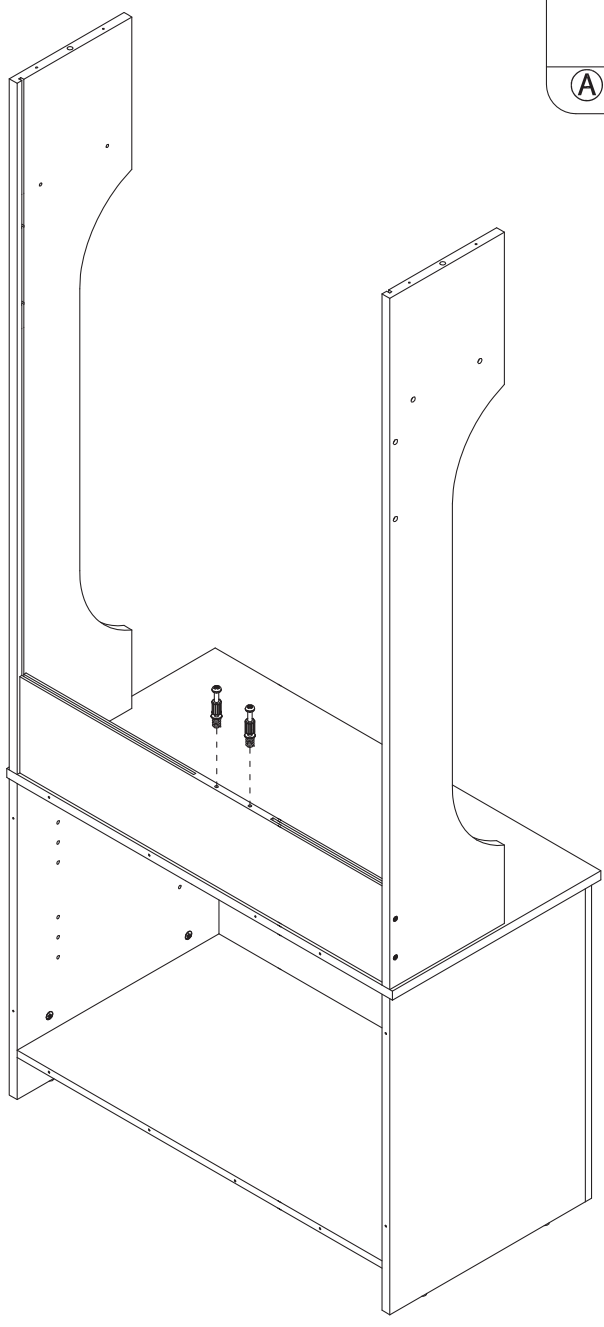
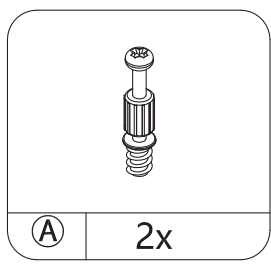

14

STEP 11

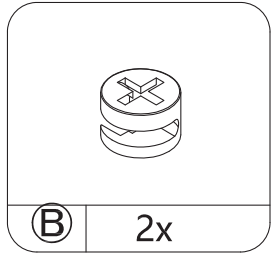
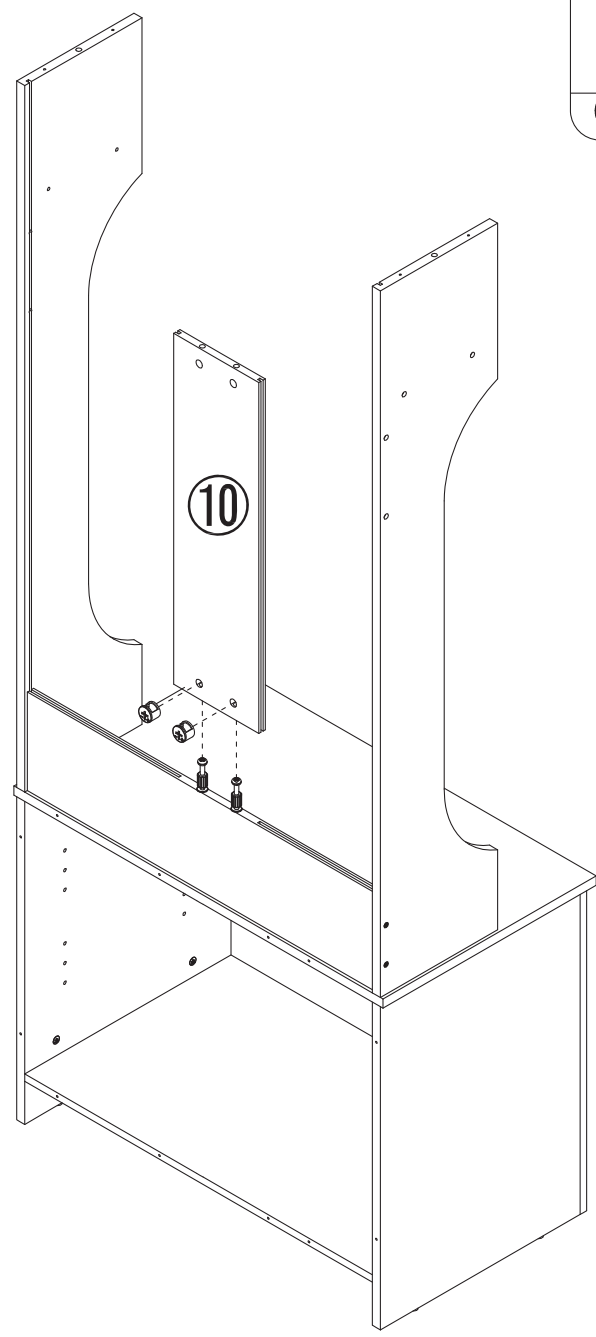

15

STEP 12

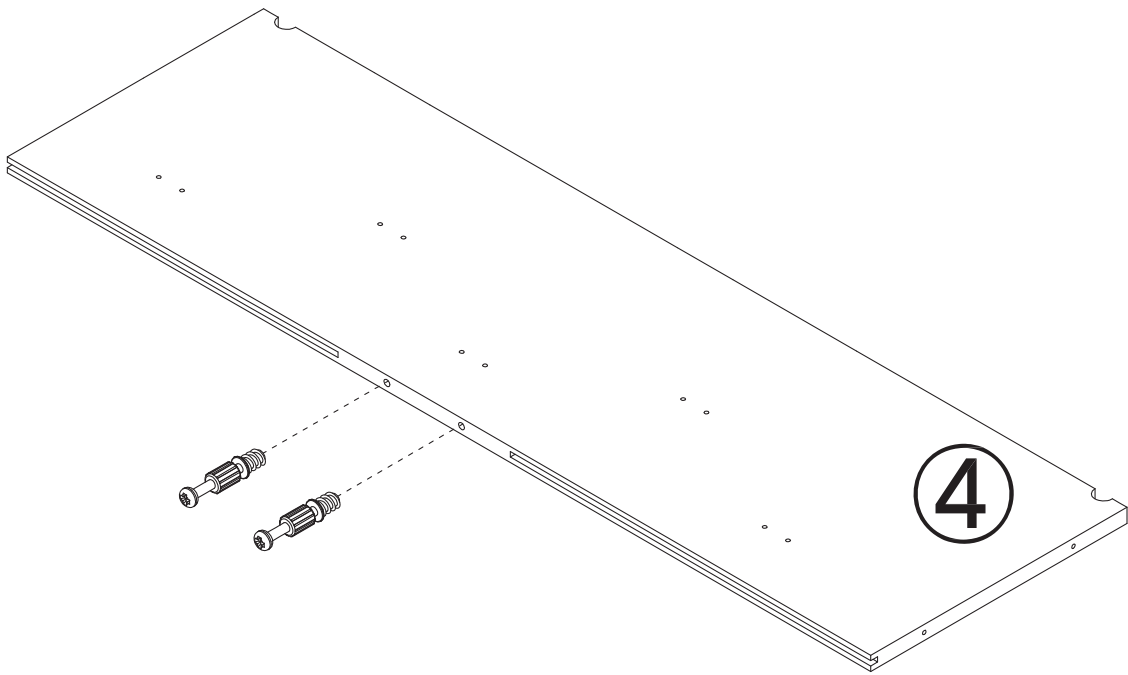
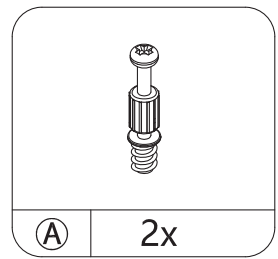

16

STEP 13

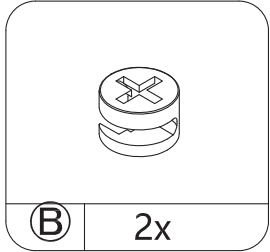
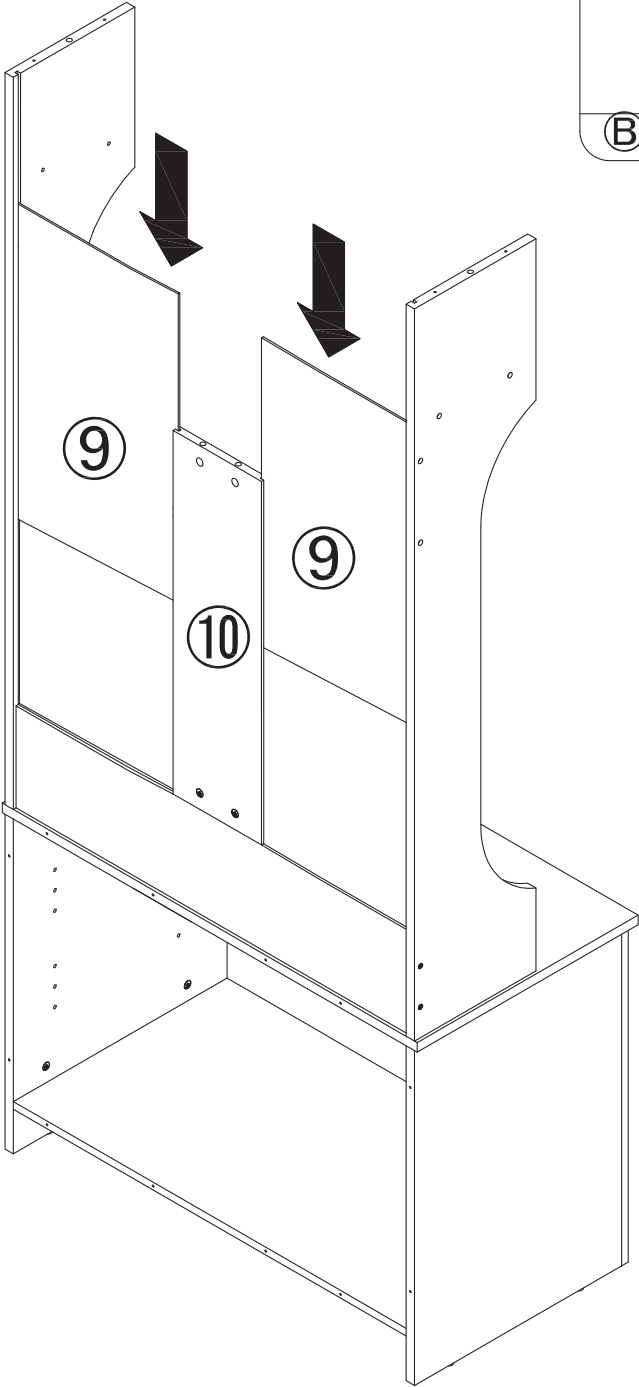

17

STEP 14

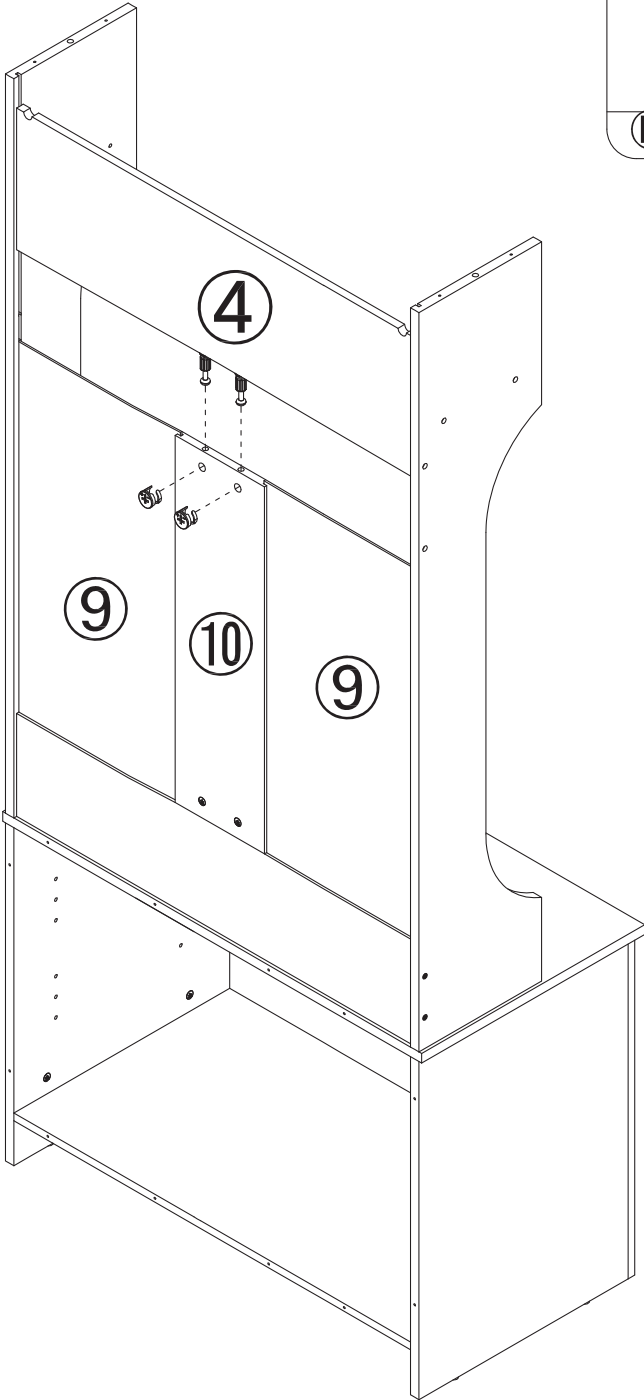
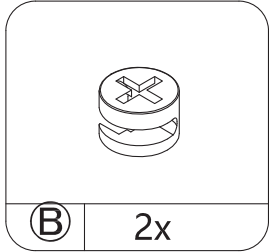

18

STEP 15

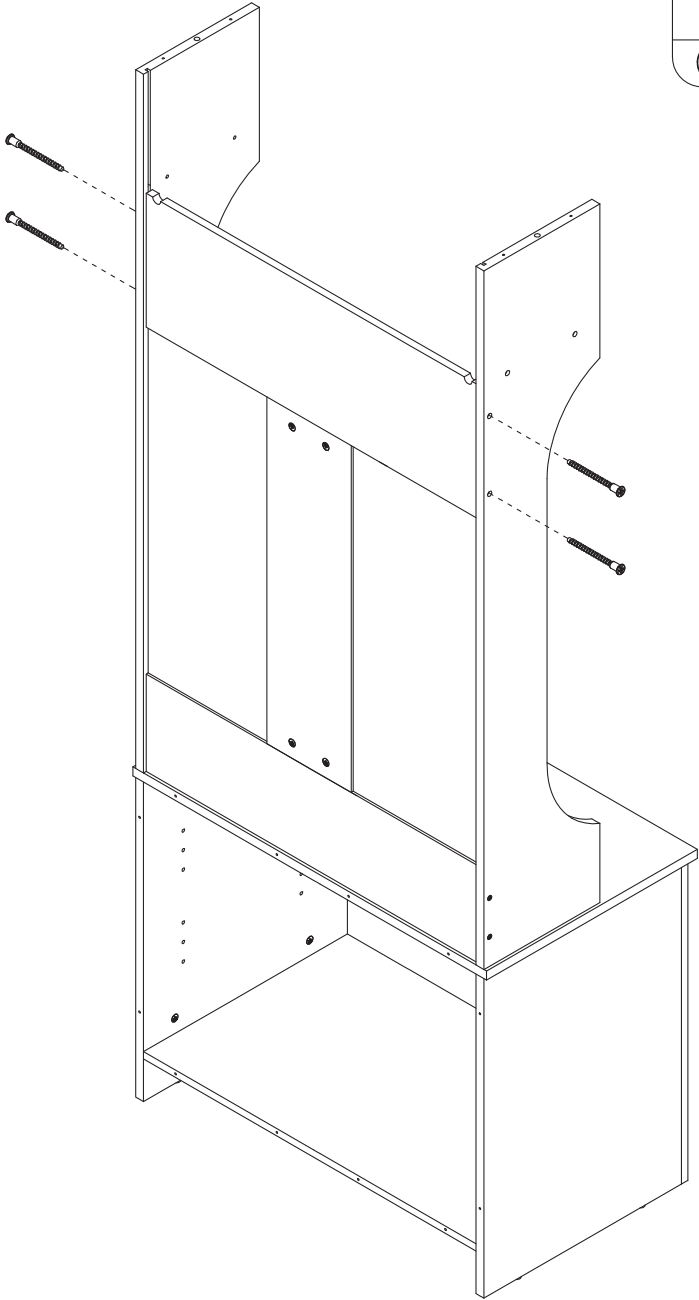
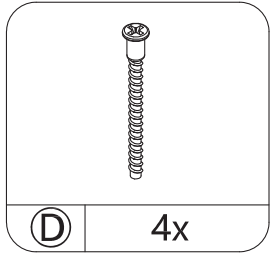

STEP 16

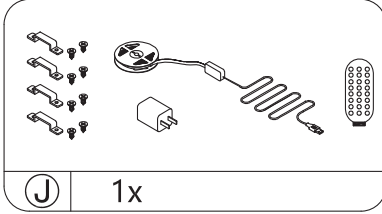
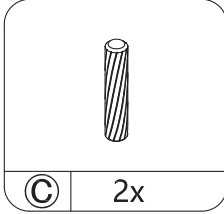
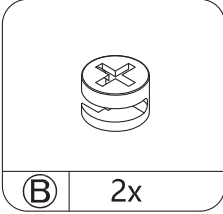
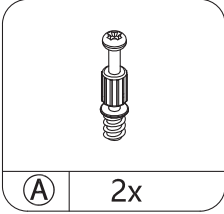

STEP 1

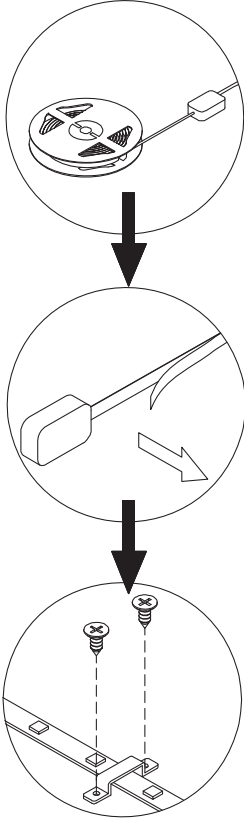
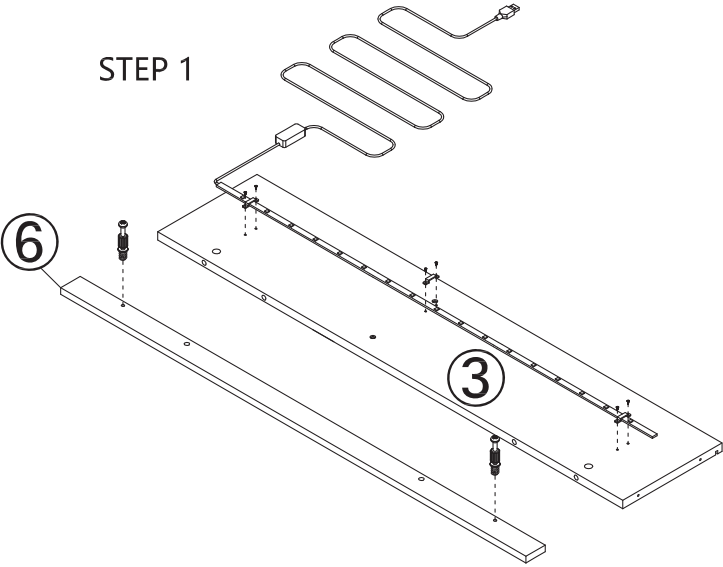

STEP 2

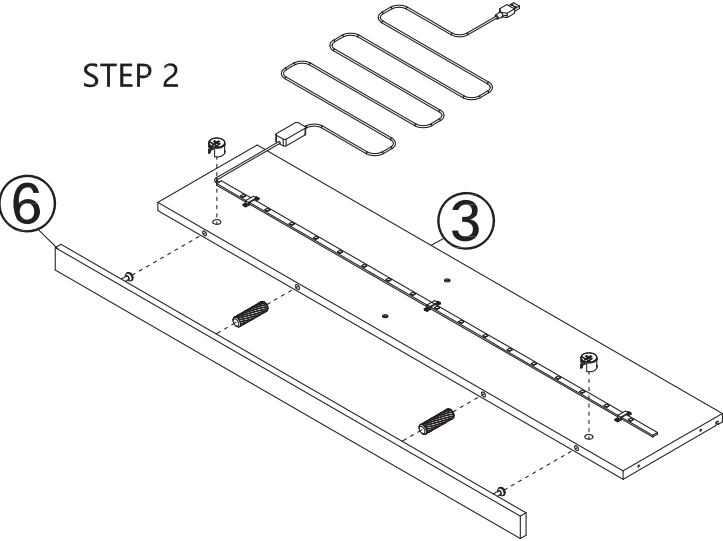

20

STEP 17

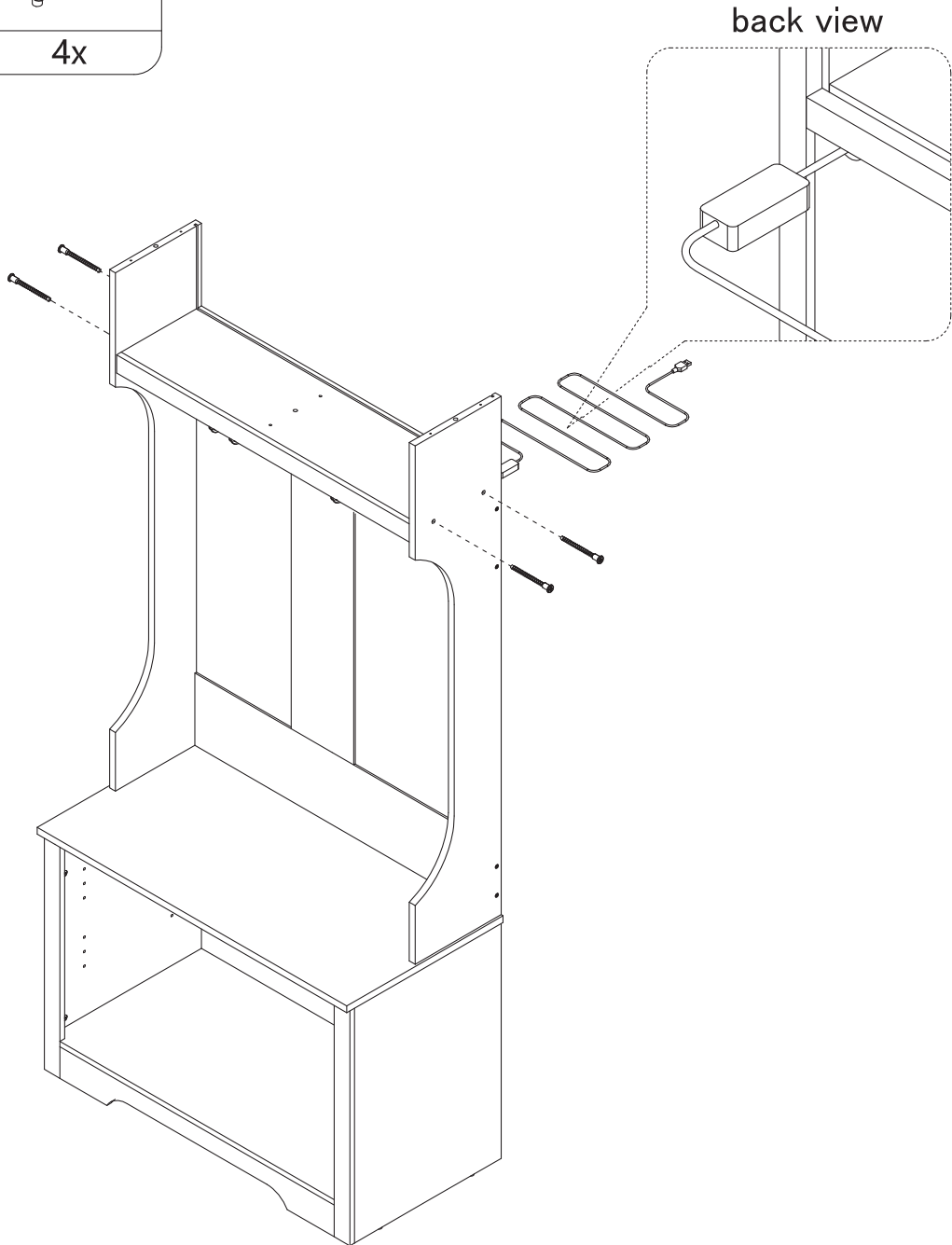
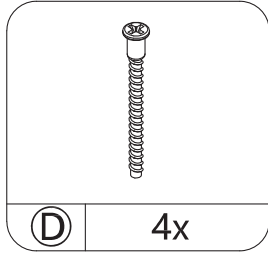

21

STEP 18

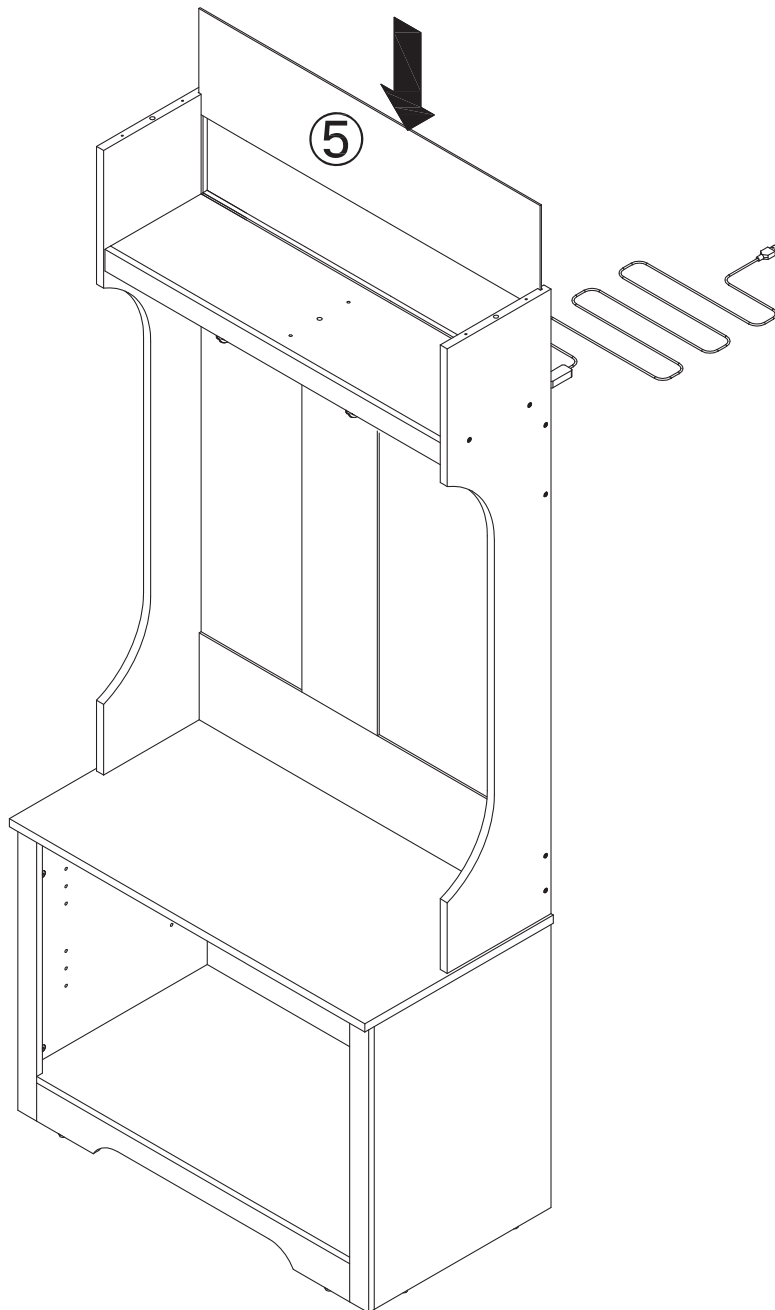

22

STEP 19

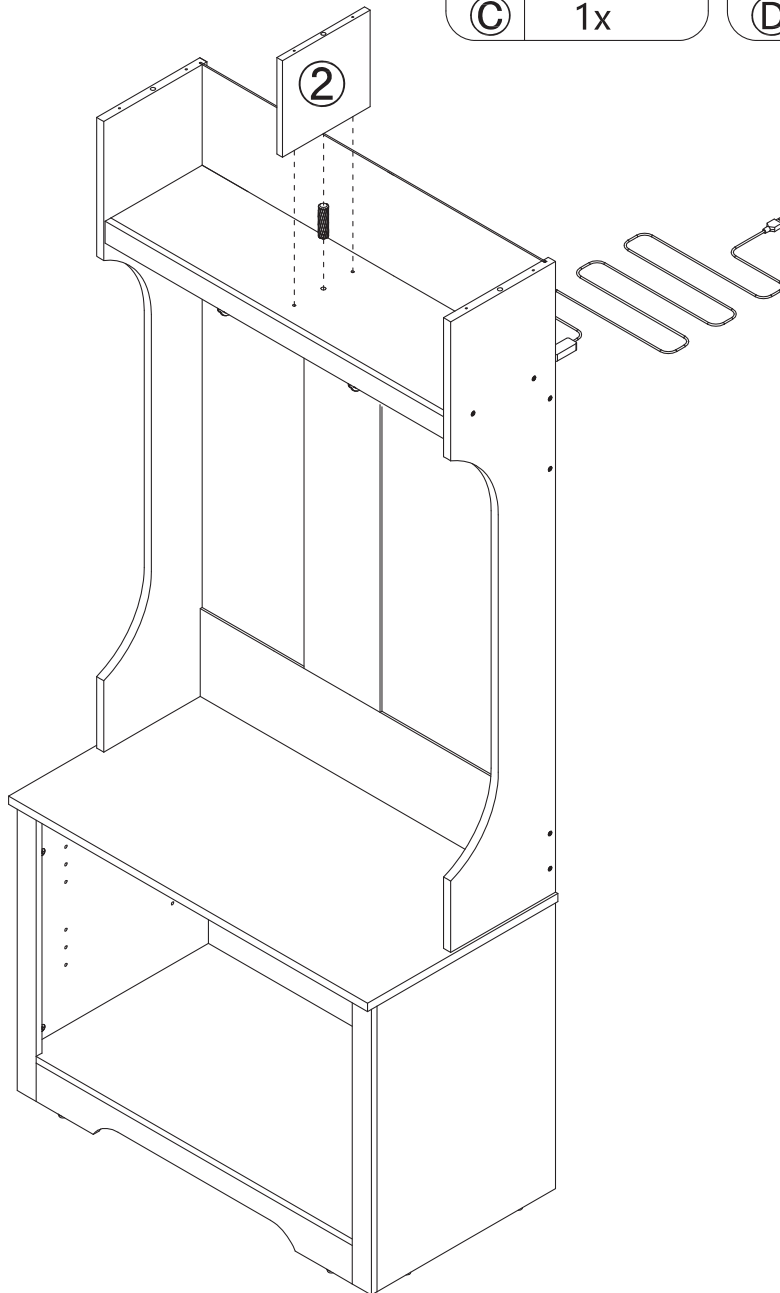
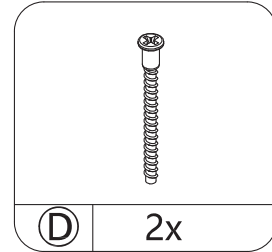
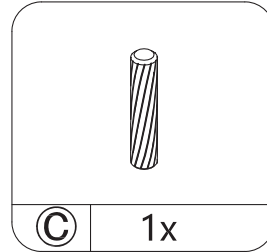

STEP 20

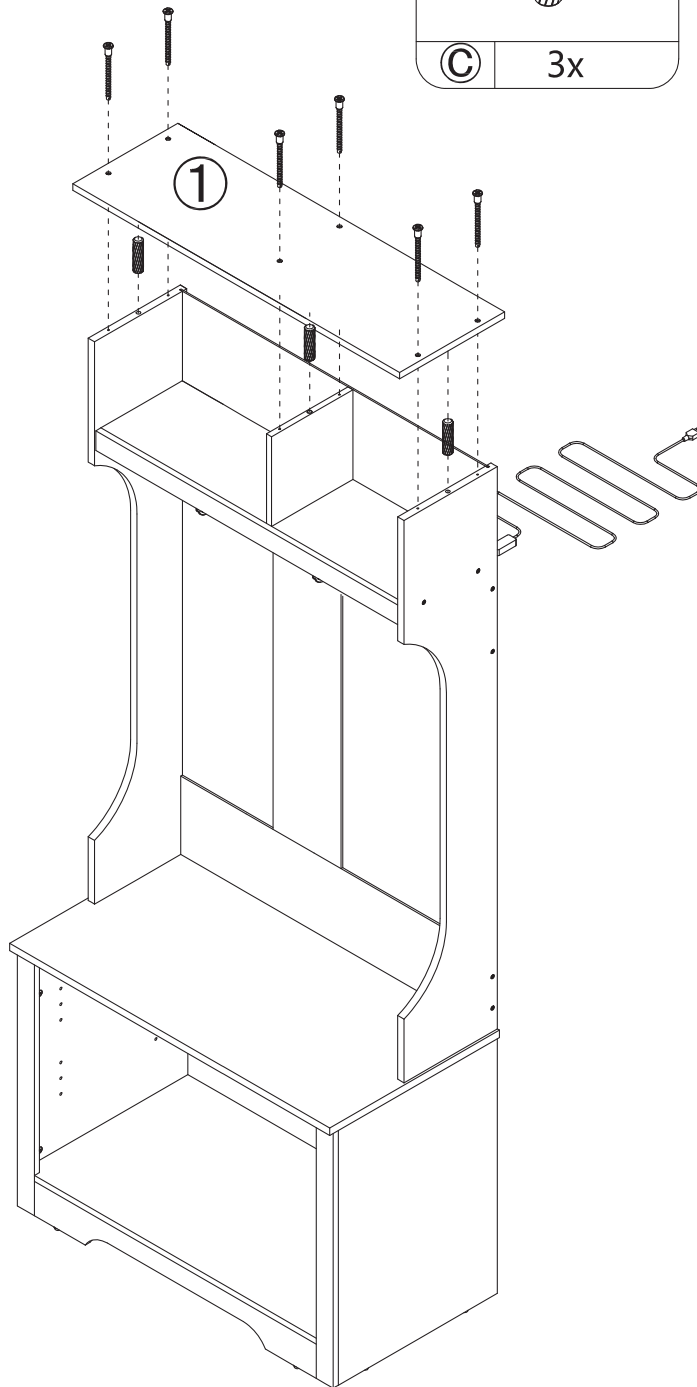
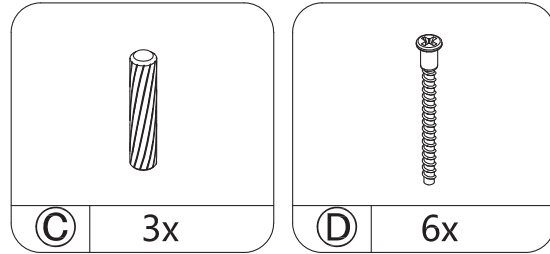

24

STEP 21

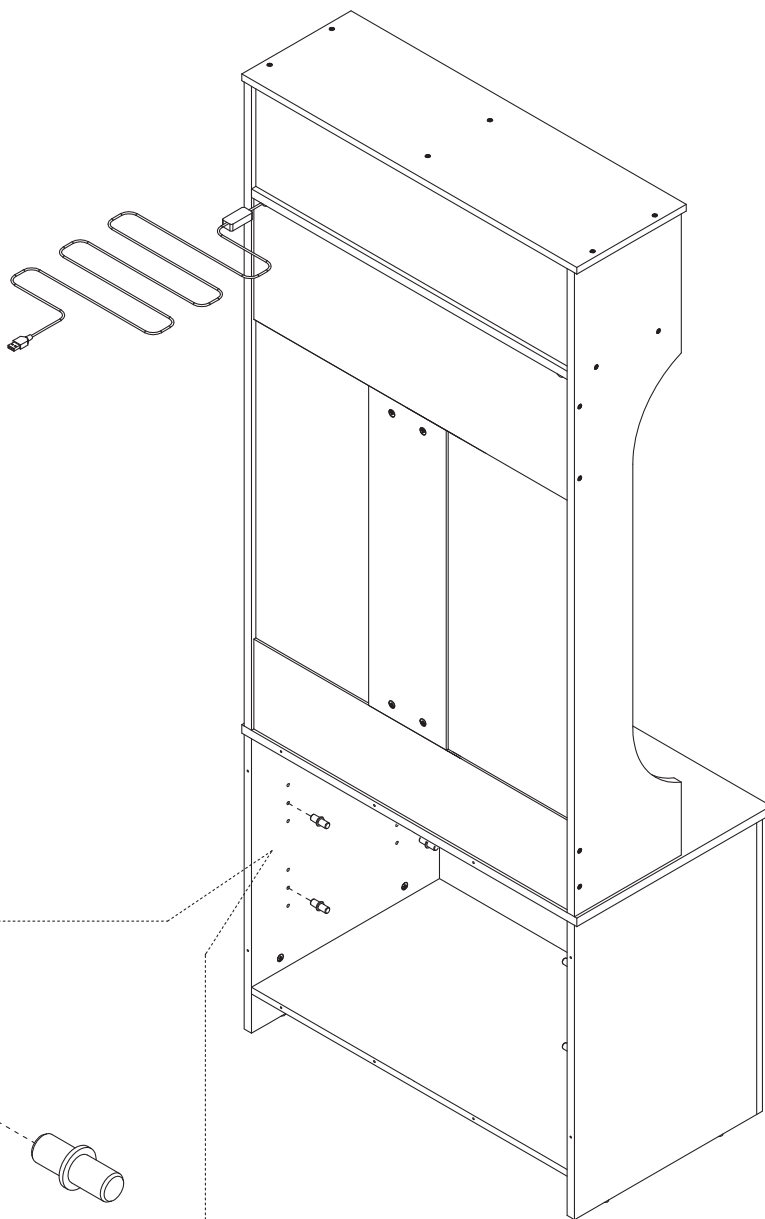
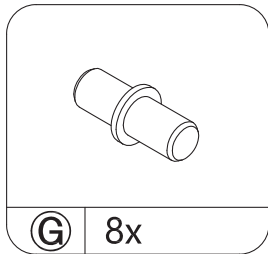

25

STEP 22

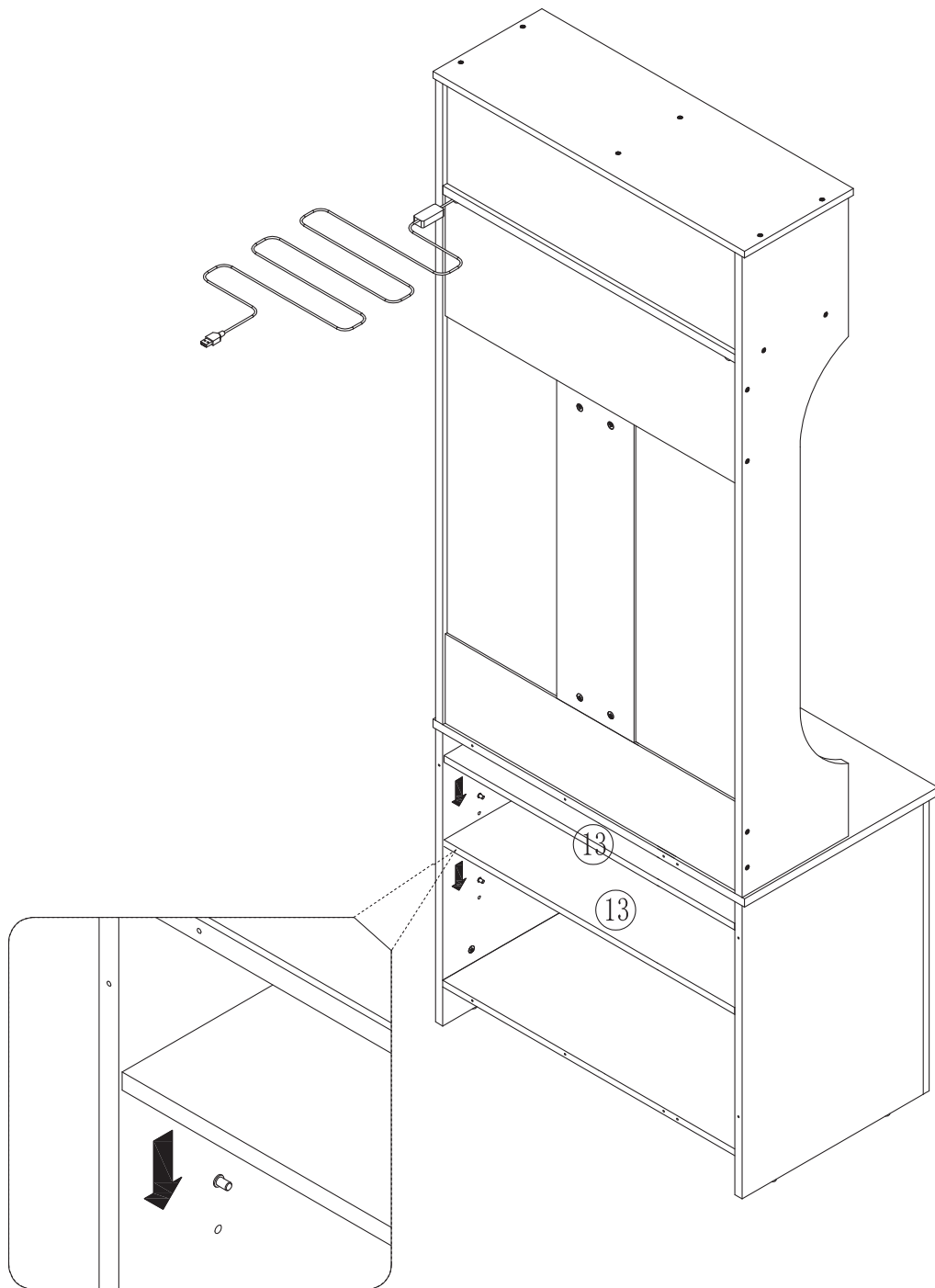

26

STEP 23

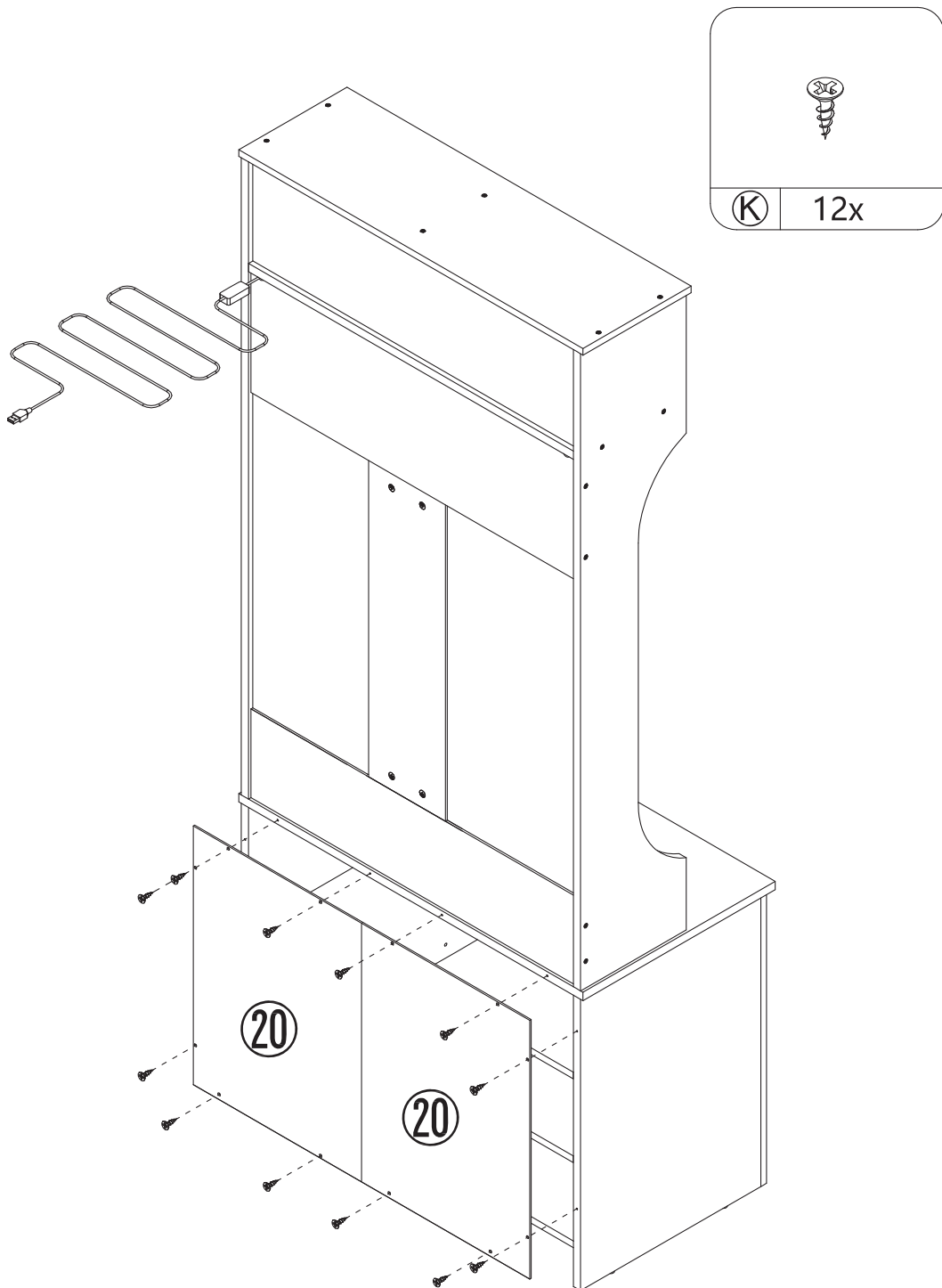

27

STEP 24

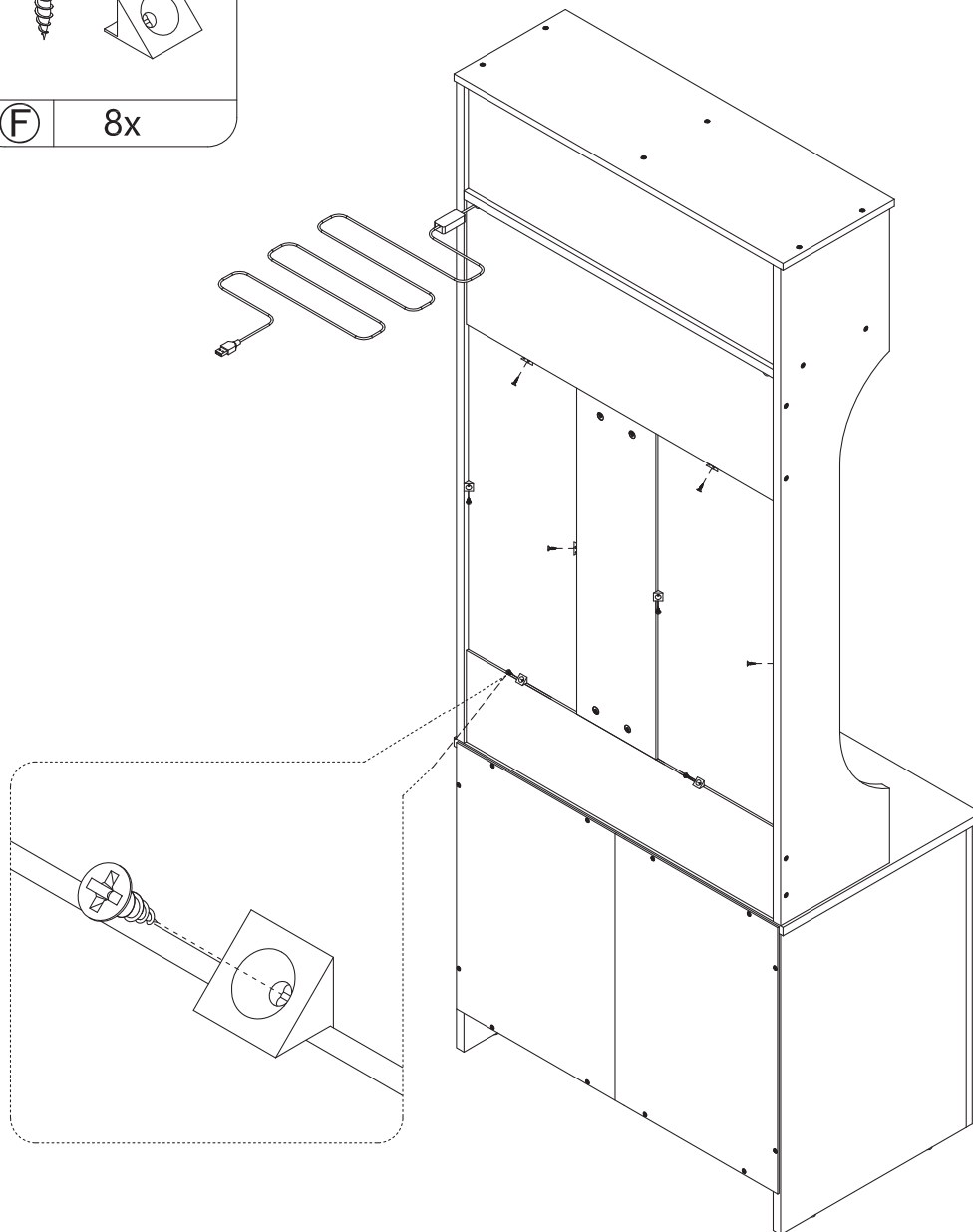
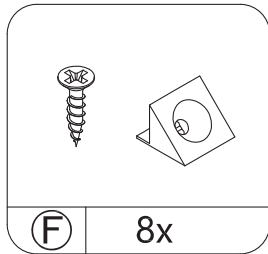

28

STEP 25

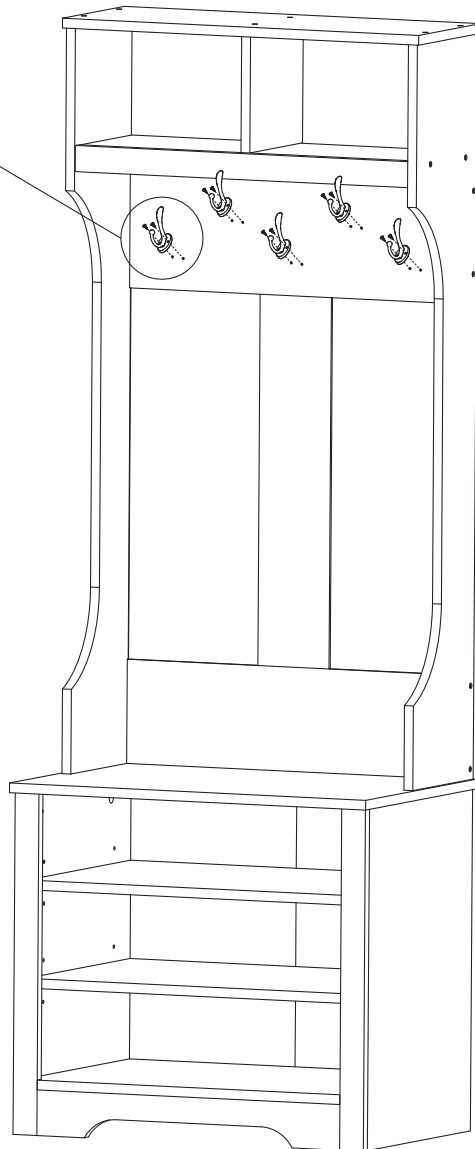
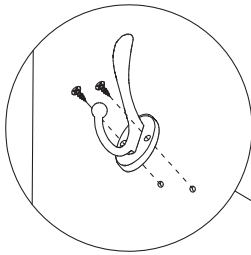
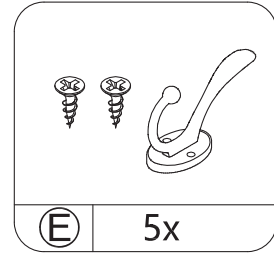

STEP 26

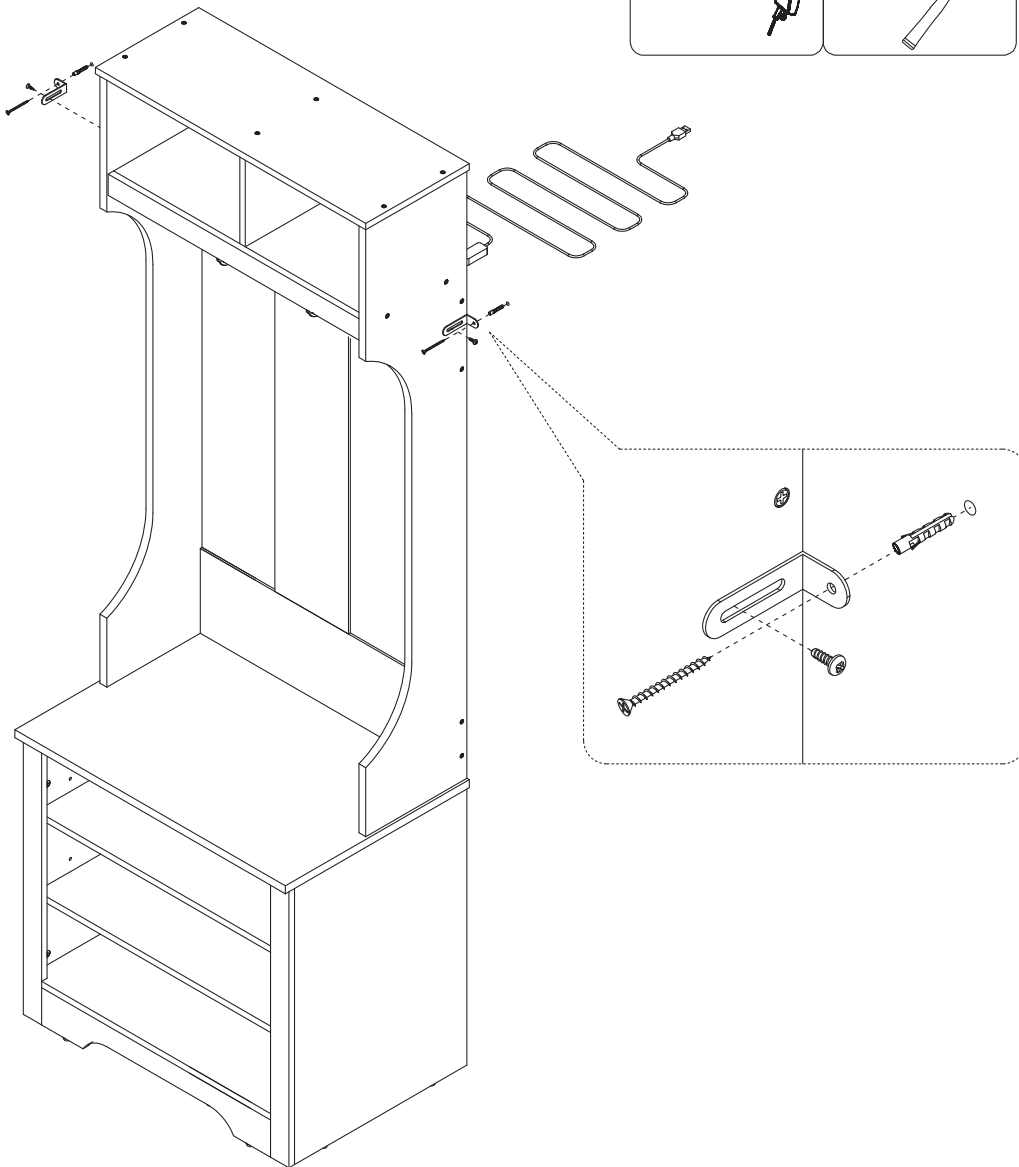
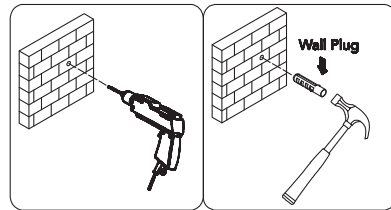
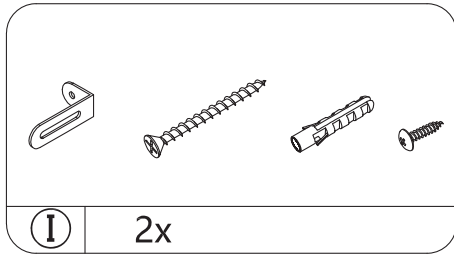

STEP 27







STEP 28







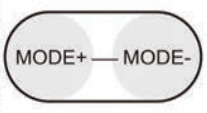
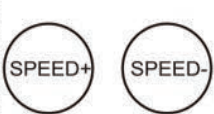

Product Parameters

- Model NO:LED Strip Lights
- LED Type:SMD5050
- Luminous Color: RGB
- Input Voltage of Adapter:DC5V
- Output Voltage of Adapter:DC5V
- Waterproof level:IP65
- Remote control range:32FT~50FT
- WorkingTemperature:-20°C~+45°C
- Beam Angle:120°

Remote control mode

	<p>In any state press these two keys to turn on/off the light strip.</p>
	<p>When light is on press these two keys to reduce-or increase+brightness there are 10 brightness levels for adjustment.And they can also adjust the rhythm sensitivity in the music rhythm mode</p>
	<p>Press relevant keys to select particular colors</p>
	<p>Press this key to switch static colors. There are 16 kinds for chosen.</p>

STEP 29

	Press this key to activate auto color changing model in which color would change automatically and circularly.
	When color changing is activated press this key to switch color changing modes. There are 21 different modes for chosen.
	When color changing is activated press this key to increase+or reduce-the changing speed There are 10 levels for chosen.
	When the light is on, press this button and the color will gradually change with the rhythm of the music. There are 1/2/3/4 default modes to choose from
	When the light is on, press this button and the colour will change to the rhythm of the music. There are 5/6/7/8 modes to choose from.
	Press this button to lock current color or color changing model.
	Press this button, it will enter the 1-hour timer, and the product will be automatically turned off after 1 hour.
	Press this button, it will enter the 2-hour timer, and the product will be automatically turned off after 2 hour.
	Press this button, it will enter the 3-hour timer, and the product will be automatically turned off after 3 hour.
	Press this button, it will enter the 4-hour timer, and the product will be automatically turned off after 4 hour.

STEP 30

APP mode

This APP program requires that the minimum systems of your phones is Android 4.3 or iOS 8.0. No limit for mobile phone configuration.

You can download APP by scanning QR codes on IOS or Android systems. Use Apps with scanning function such as browser to scan the QR code.

Please open the strips lights control APP on your phone by which you can connect one or more LED strip through Bluetooth and able to set and control multiple LED strip.

Functions are listed as follows:

1. Adjust the brightness and color temperature of 60 kinds of colors for both colorful LED strip and monochrome LED strip;
2. Playing any music on your phone or in the Apps with music function would make the colors and brightness of the light change automatically according with the music rhythm, which is absolutely beautiful.
3. The multiple color change modes makes the color change automatically and would keep changing even the phone is disconnected with the strips lights.
4. Long distance control without direction restriction and multiple controls is allowed.
5. Once been connected, your phone would connect to the light strips automatically after you turn on your bluetooth.

STEP 31

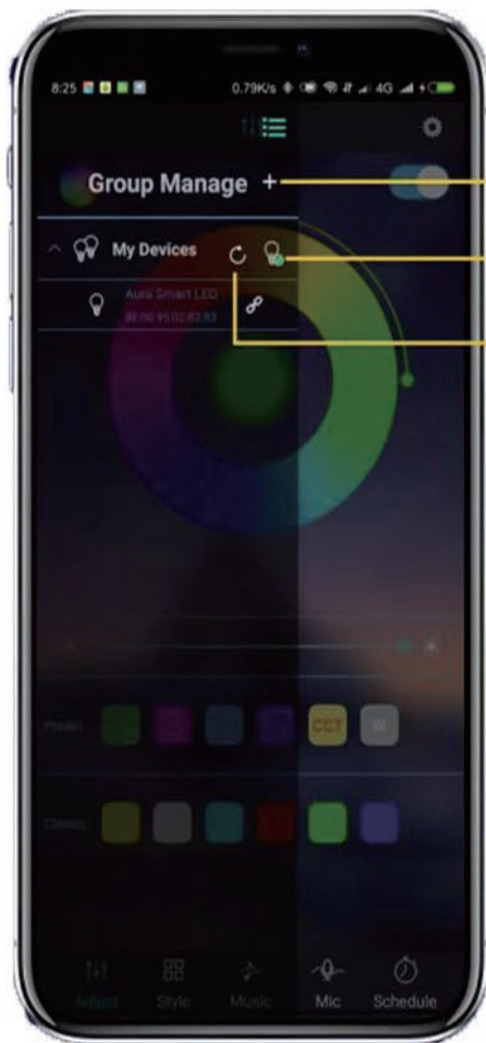

Click to go to Group Management

Click to select device

Click to select the most recently connected device

STEP 32

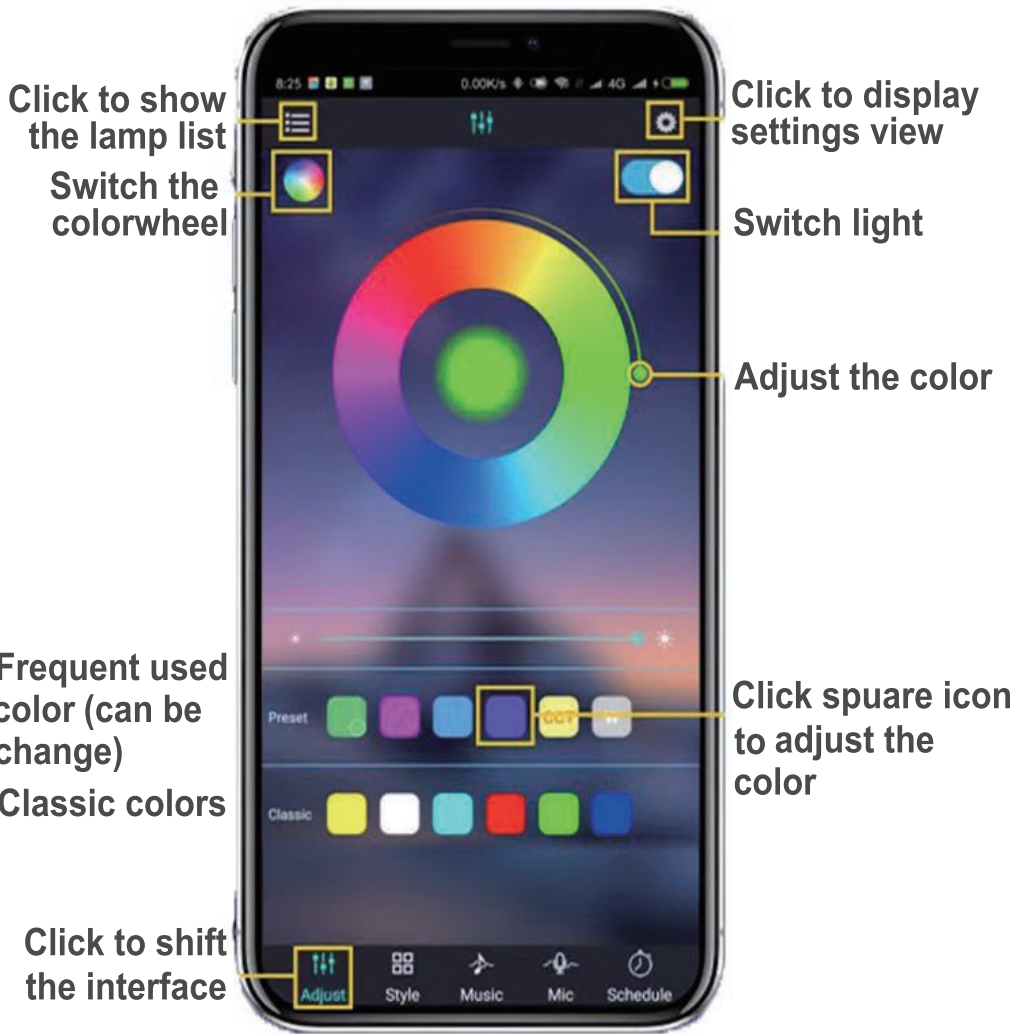

STEP 33

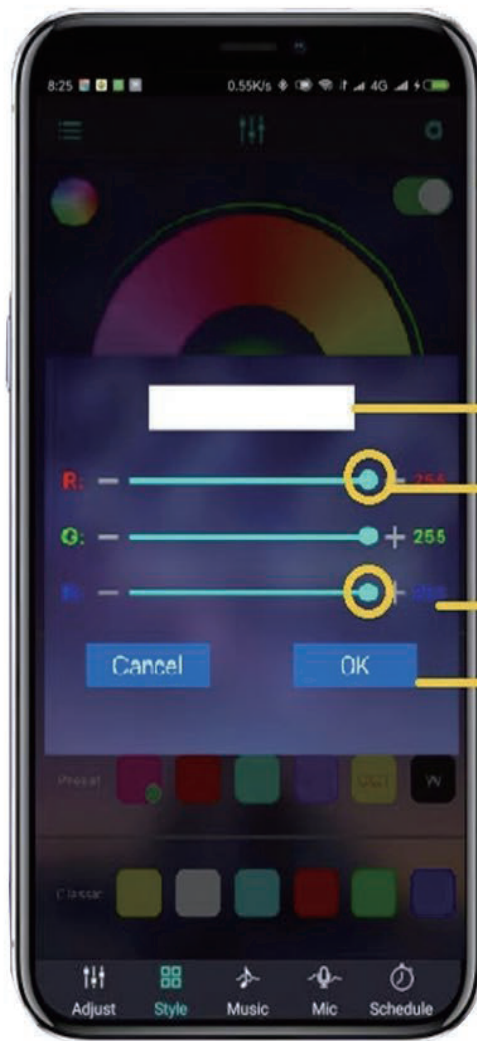

Show the modified color

Adjust the RGB values separately

RGB value

Save the new values

STEP 34



↑
Scroll the
selection mode
↓

STEP 35

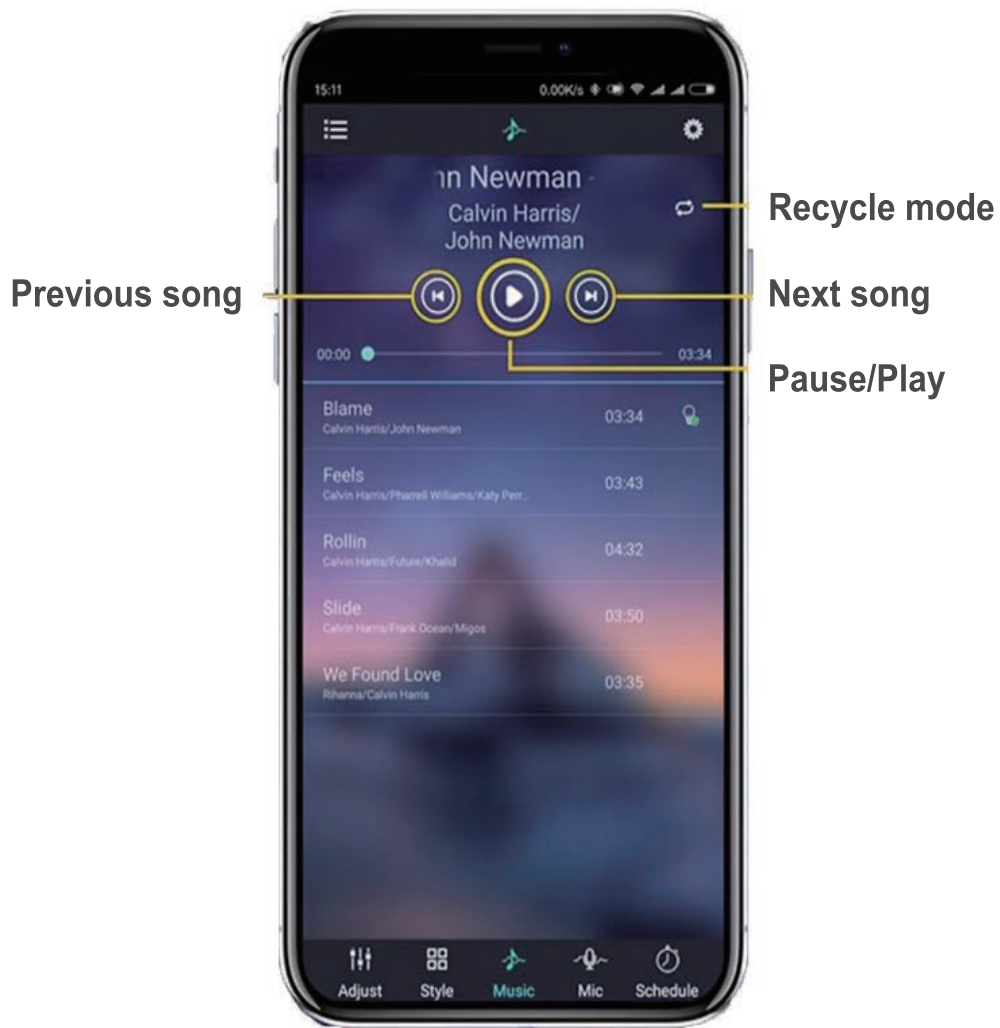

STEP 36

Color change according to the surrounding voices change

Pause/resume rhythmic function

Capture the sound by the microphone of the phone

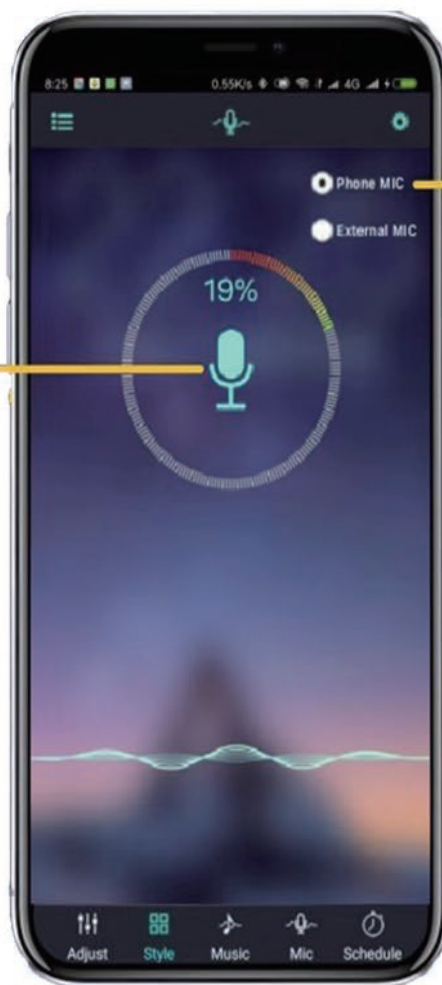

STEP 37

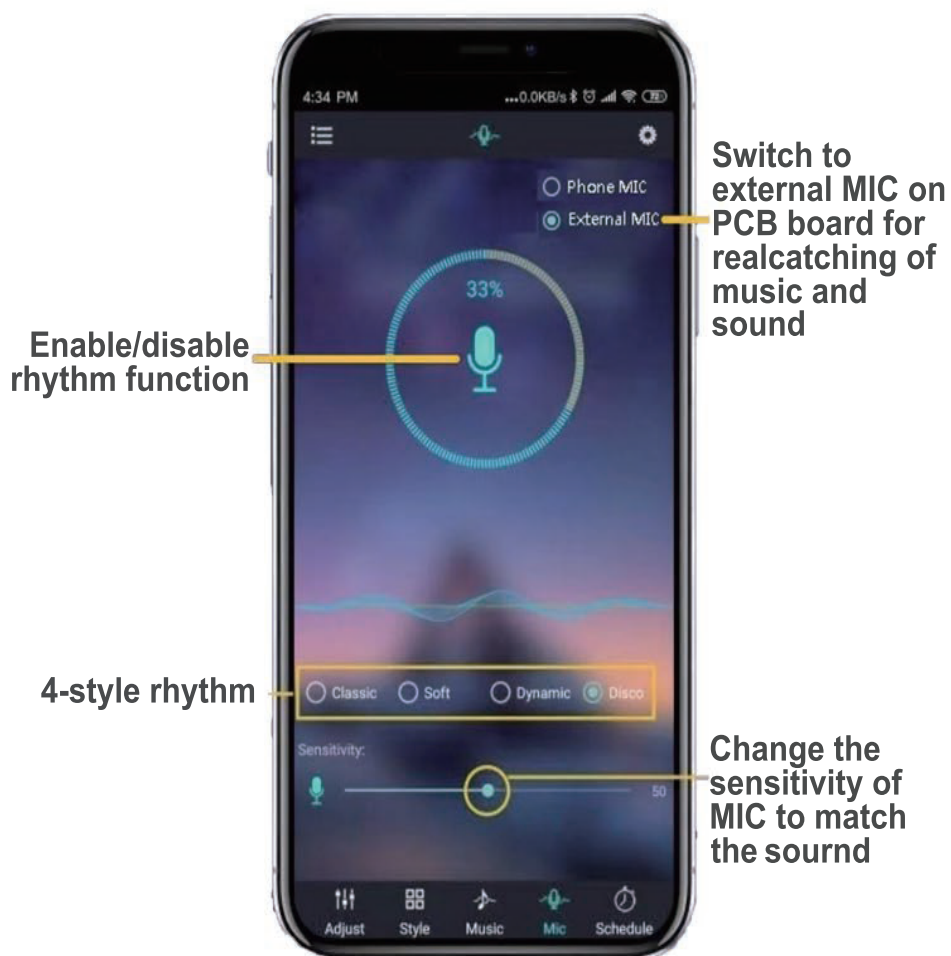

STEP 38

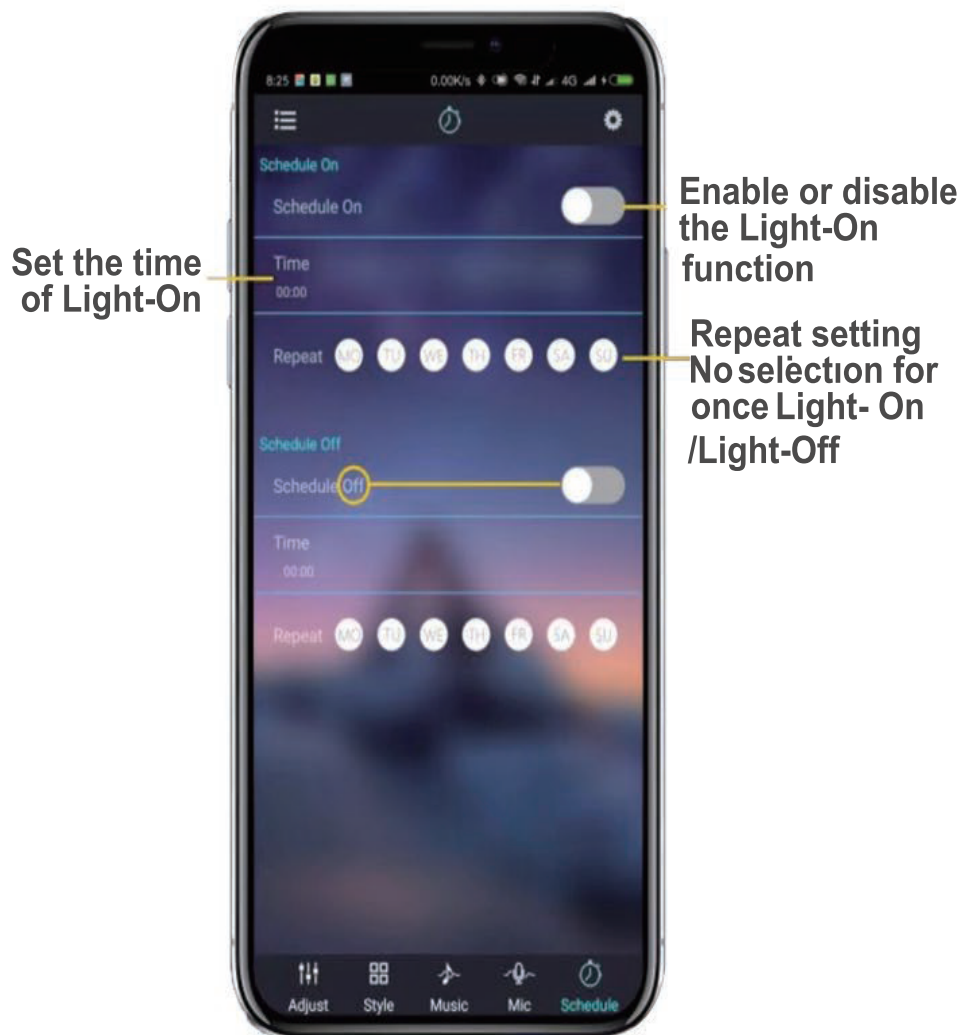

STEP 39

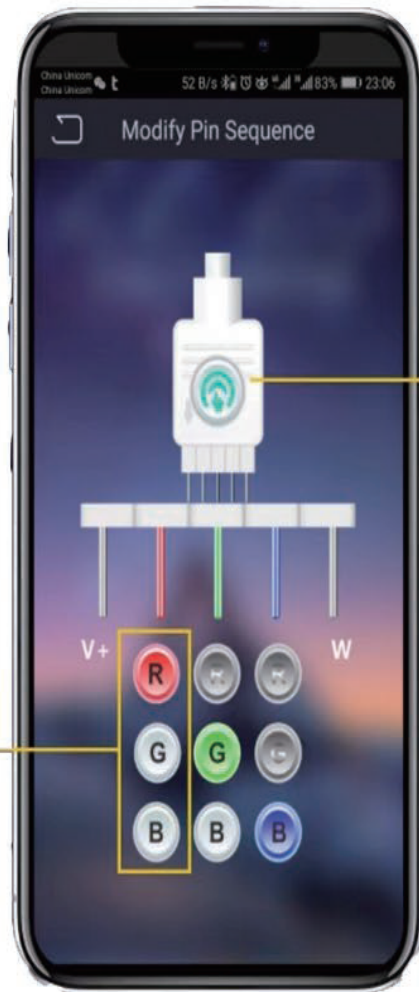

Click to save the new assignment

Change the real color- of this line

STEP 40

Common Troubleshooting

The controller was connected the power, but not light up

1. Check the input power supply: please use the power adapter that we equipped or other adapters with the same specification as ours. The input voltage must meet the voltage requirement of the strips lights. When the input voltage is lower than requirement the strips lights will not be turn on, while higher voltage may damage the circuit.

The output power of the adapter(KWvalue) must equals too higher than the power of the LED strips lights.

2. Check whether the connector is connected correctly with the strips lights. Make sure each interface is connected correctly

3. Check whether the remote control is open.

If the LED strips light able to light up, but the remote control does not

work or can't control LED light.

1. Check whether the insulation sheet is removed from the remote control

2. Make sure the battery on the remote control is installed correctly

3. Ensure that the remote is working.

4. Try to replace the battery.

Attentions:

1. Light strip must be used under DC5V.

2. The light strips are IP65 waterproof and are suitable for indoor and outdoor. But the controller and power supply are not waterproof. Some all recommend hiding them away from water during use.

3. Make sure the surface you are going to paste strip is clean and dry.

STEP 41



WARNING

DO NOT IMMERSE IN FIRE
CHILDREN UNDER THE AGE OF
16 SHOULD USE THIS PRODUCT
UNDER ADULT SUPERVISION.

FCC Regulatory Compliance

This device complies with part 15 of the FCC Rules. Operation is subject to the following two conditions:

(1) This device may not cause harmful interference, and (2) this device must accept any interference received, including interference that may cause undesired operation.

Warning: Changes or modifications not expressly approved by the party responsible for compliance could void the user's authority to operate the equipment.

Note: This equipment has been tested and found to comply with the limits for a Class B digital device, pursuant to Part 15 of the FCC Rules.

These limits are designed to provide reasonable protection against harmful interference in a residential installation. This equipment generates, uses and can radiate radio frequency energy and, if not installed and used in accordance with the instructions, may cause harmful interference to radio communications. However, there is no guarantee that interference will not occur in a particular installation.

If this equipment does cause harmful interference to radio or television reception, which can be determined by turning the equipment off and on, the user is encouraged to try to correct the interference by one or more of the following measures:

- Reorient or relocate the receiving antenna.
- Increase the separation between the equipment and receiver.
- Connect the equipment into an outlet on a circuit different from that to which the receiver is connected.
- Consult the dealer or an experienced radio/TV technician for help.