

ASSEMBLY INSTRUCTIONS

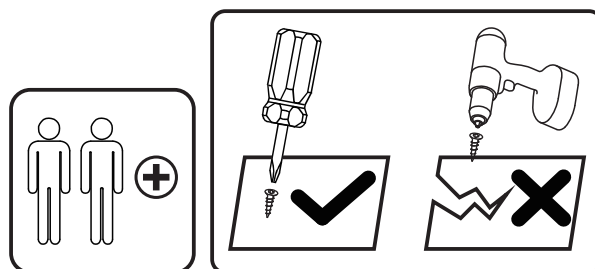

Tools Recommended

THIS INSTRUCTIONS CONTAINS IMPORTANT SAFETY INFORMATION.
PLEASE READ BEFORE ASSEMBLY AND KEEP FOR FUTURE REFERENCE.

IMPORTANT NOTICE

- This product contains small components, please ensure that they are kept away from small children.
- THIS INSTRUCTIONS CONTAINS IMPORTANT SAFETY INFORMATION. PLEASE READ BEFORE ASSEMBLY AND KEEP FOR FUTURE REFERENCE.
- Read each step carefully. It is very important that each step of instruction is performed in the correct order. If these steps are not followed in sequence, assembly difficulties will occur.
- Make sure all parts are included. Most parts are labelled or stamped on the raw edge.
- Work in spacious area, preferably on a carpet, near the place the unit will be used.
- Do not use power tools to assemble your furniture. Power tools may strip or damage the parts.
- Move your new furniture carefully, with two people lift and carry the unit to it's new location.
- Never push, drag or pull your furniture (especially on carpet)











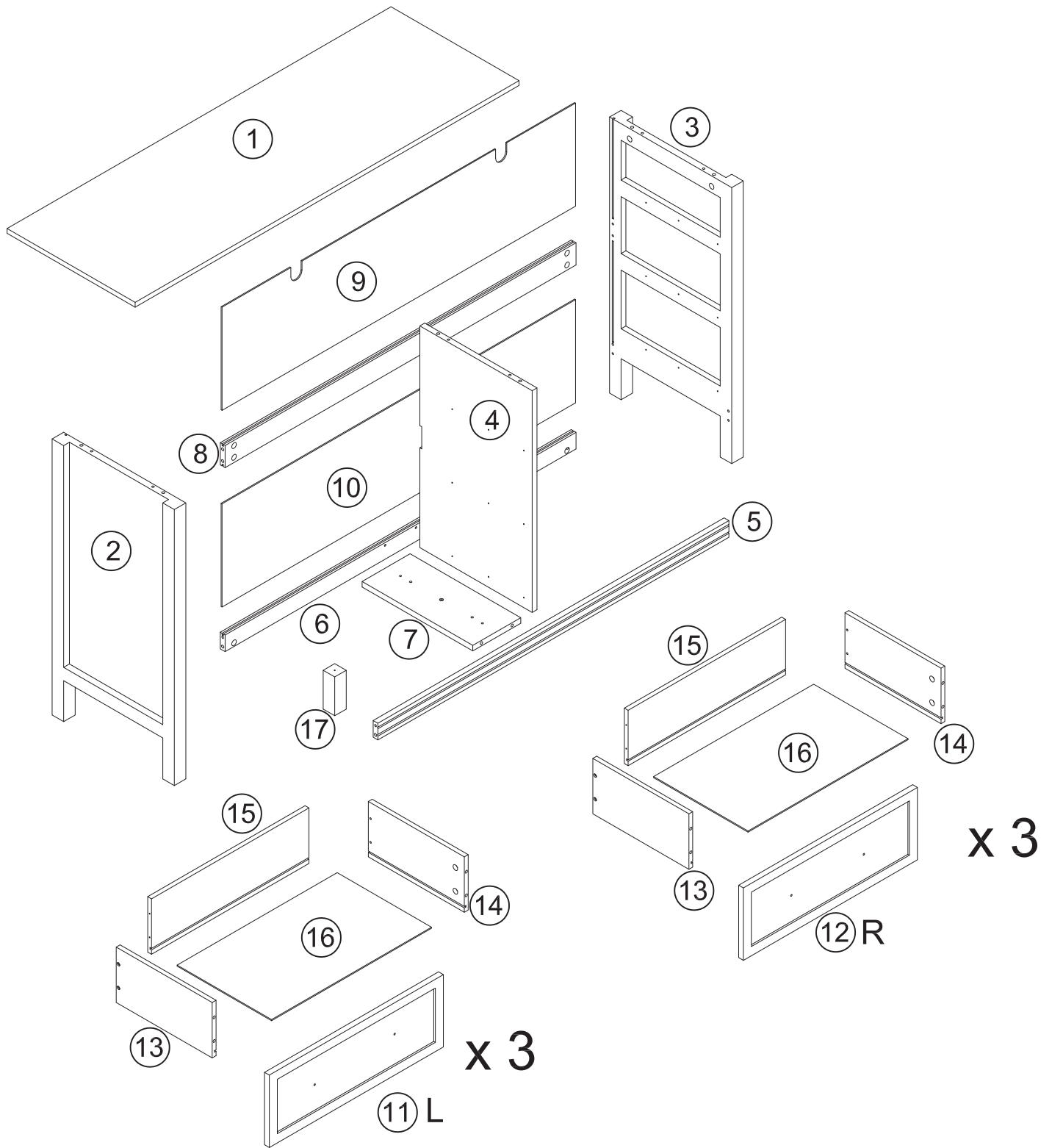









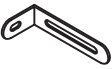

PLEASE DO NOT RETURN PRODUCT TO US IMMEDIATELY

If a part is missing or damaged, email our customer service. We will gladly ship your replacement parts FREE of charge.

For Prompt, reliable service, please have your assemble instruction ready.

|  WARNING | |
|--|---|
|  | <p>Children have died from furniture tipover. To reduce the risk of furniture tipover:</p> <ul style="list-style-type: none">• ALWAYS install tipover restraint provided.• NEVER put a TV on this product.• NEVER allow children to stand, climb or hang on drawers, doors, or shelves.• NEVER open more than one drawer at a time.• Place heaviest items in the lowest drawers. |
|  | |



| | | | | | | |
|---|---|---|---|---|---|---|
| A x42  Ø6x35mm | B x42  | C x12  6x30mm | D x72  3.5x12mm | E x4  5x40mm | F x24  4x30mm | G x12  3x14mm |
| H x12  | I x12  4x16mm | J x12  | K x2  | L x2  4x12mm | M x2  | N x2  4x35mm |
| O x4  | P x1  | CL x6  | CR x6  | DL x6  | DR x6  | |

STEP 1

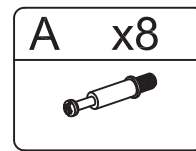
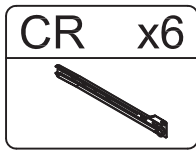
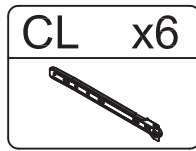
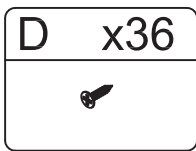
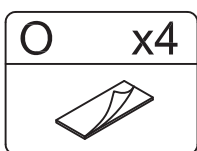
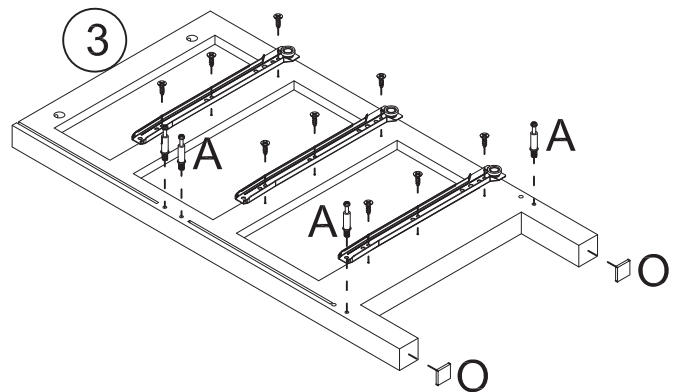
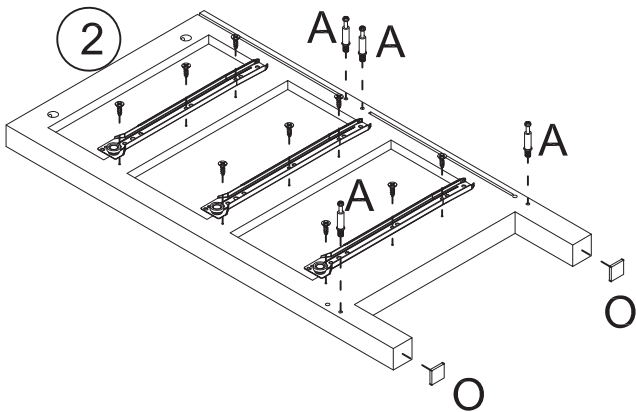
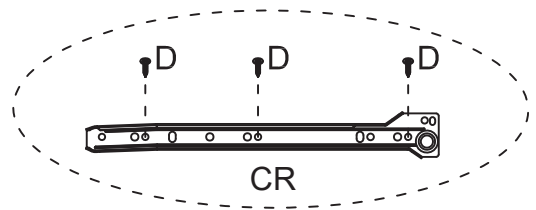
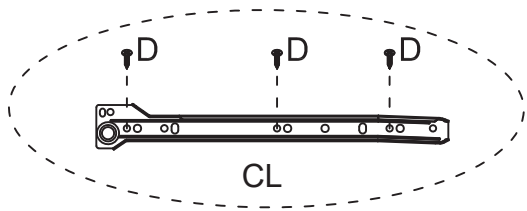
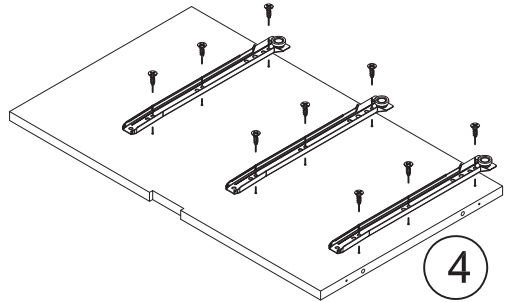
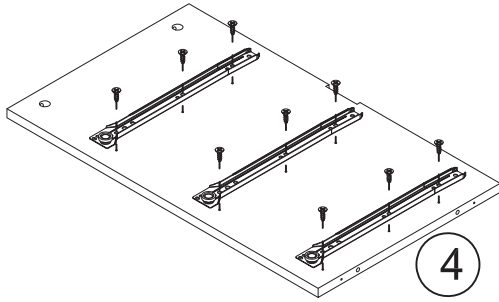
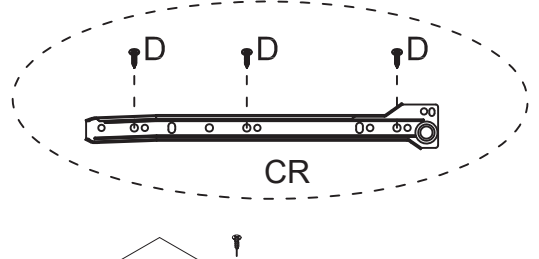
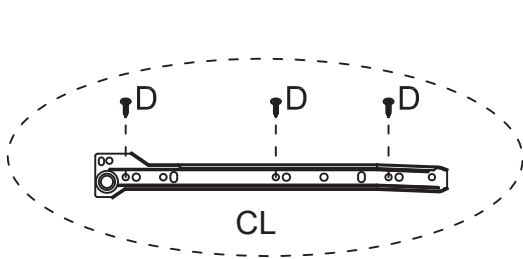
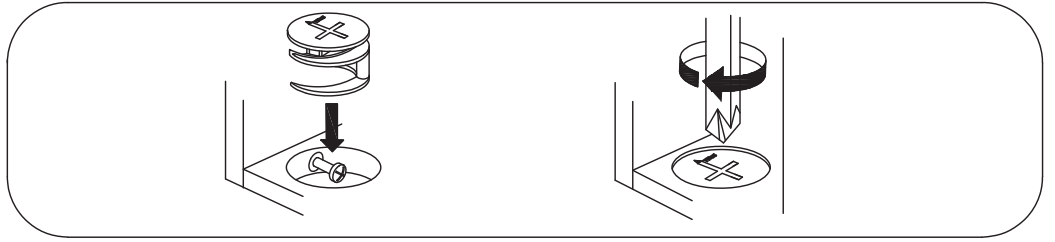
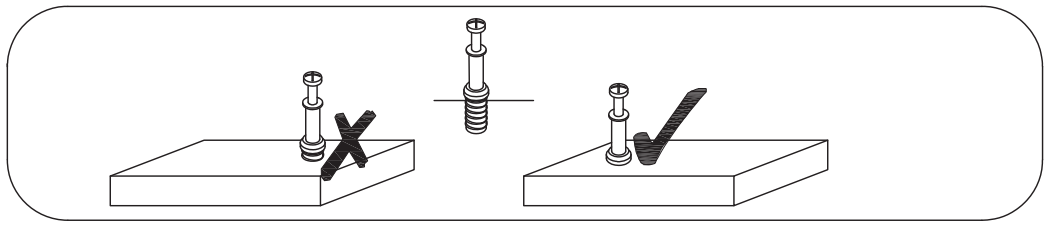

STEP 2

Install the screw A on the part 6,5 and then put the eccentric B into the corresponding hold and use a flat-blade screwdriver to turn it clockwise to tighten, the installation position is as shown below.

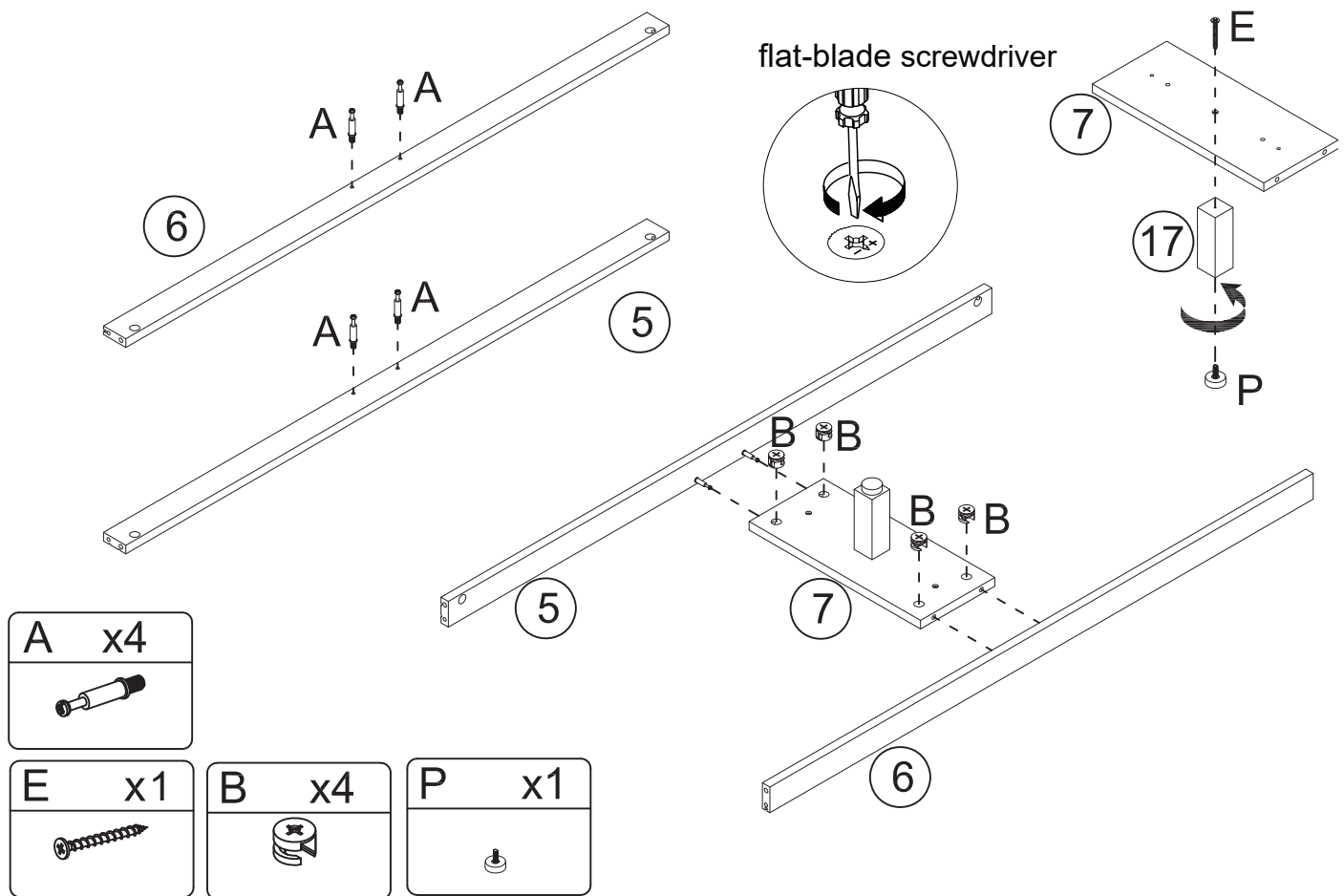

STEP 3

Insert the dowel C into part 4 first, then assemble parts 8, 6, 5 and part 4, the installation position is as shown below.

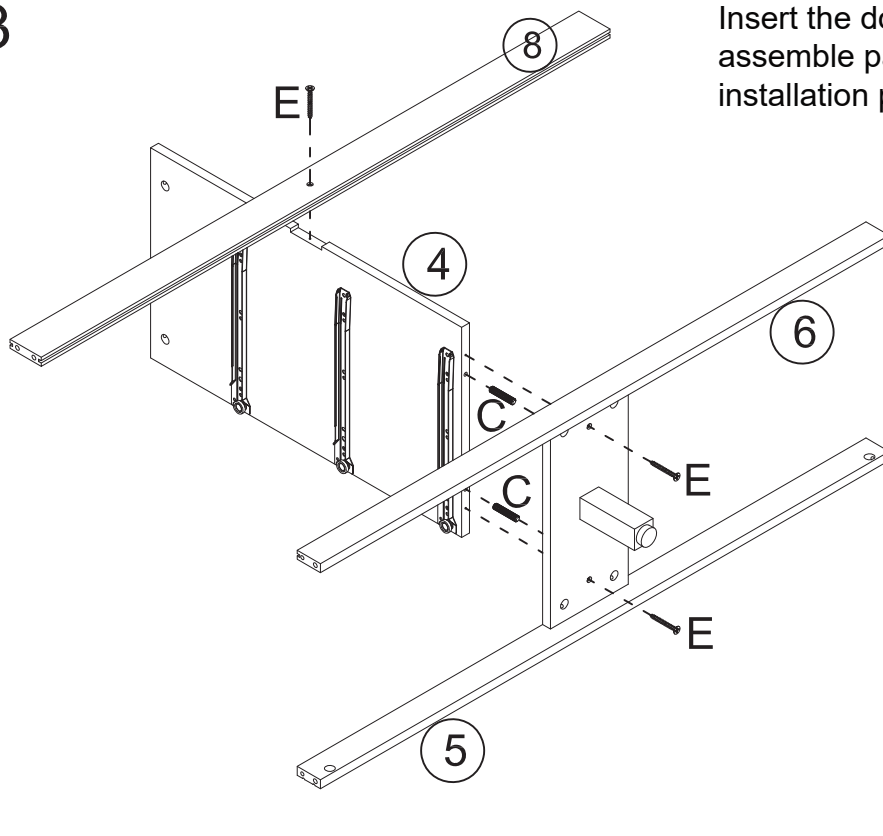

STEP 4

Insert the dowel C into part 2 first, then assemble parts 8, 6, 5 and part 2, put the eccentric B into the corresponding hole and use a flat-blade screwdriver to turn it clockwise to tighten, the installation position is as shown below.

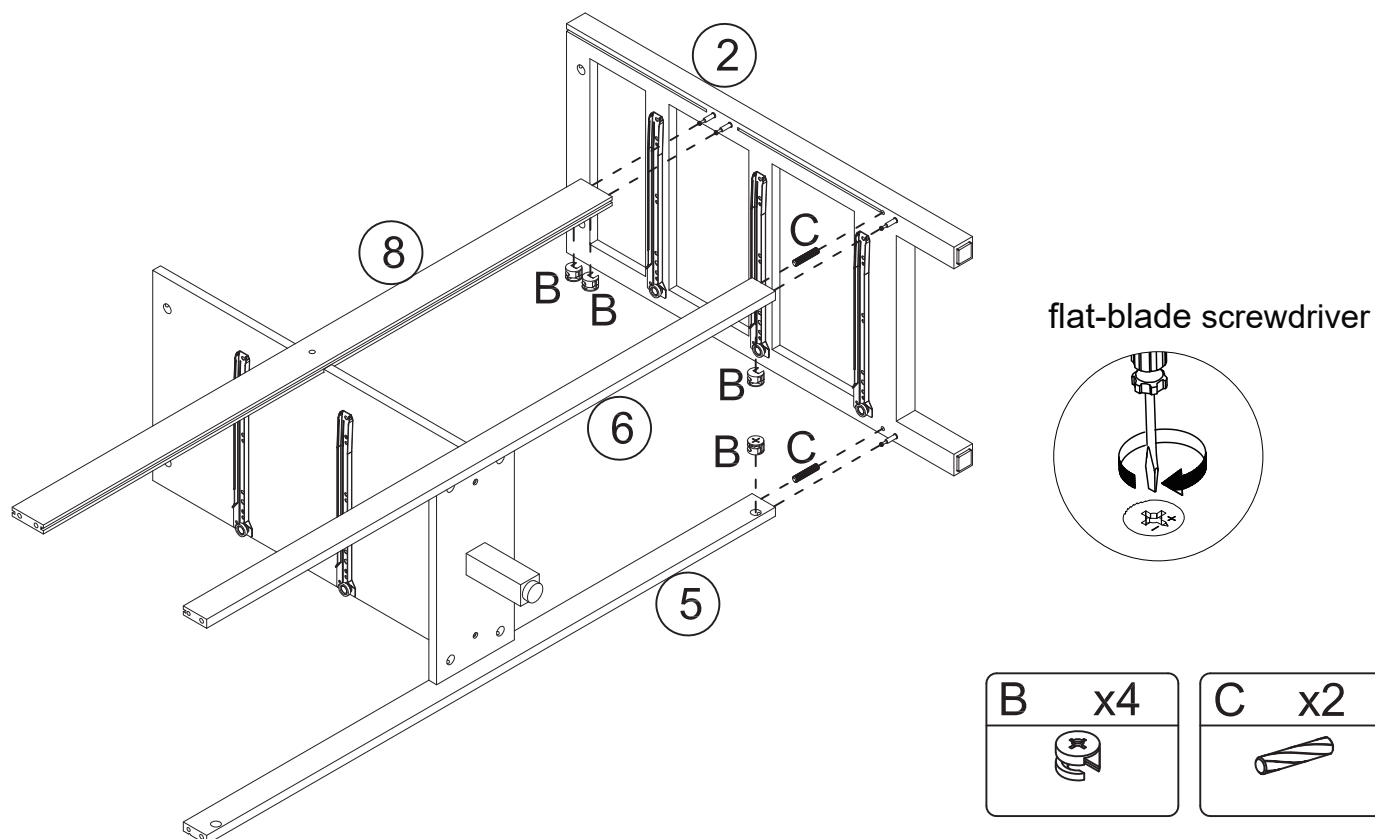

STEP 5

Insert part 10 along the slot, the position is as shown below.

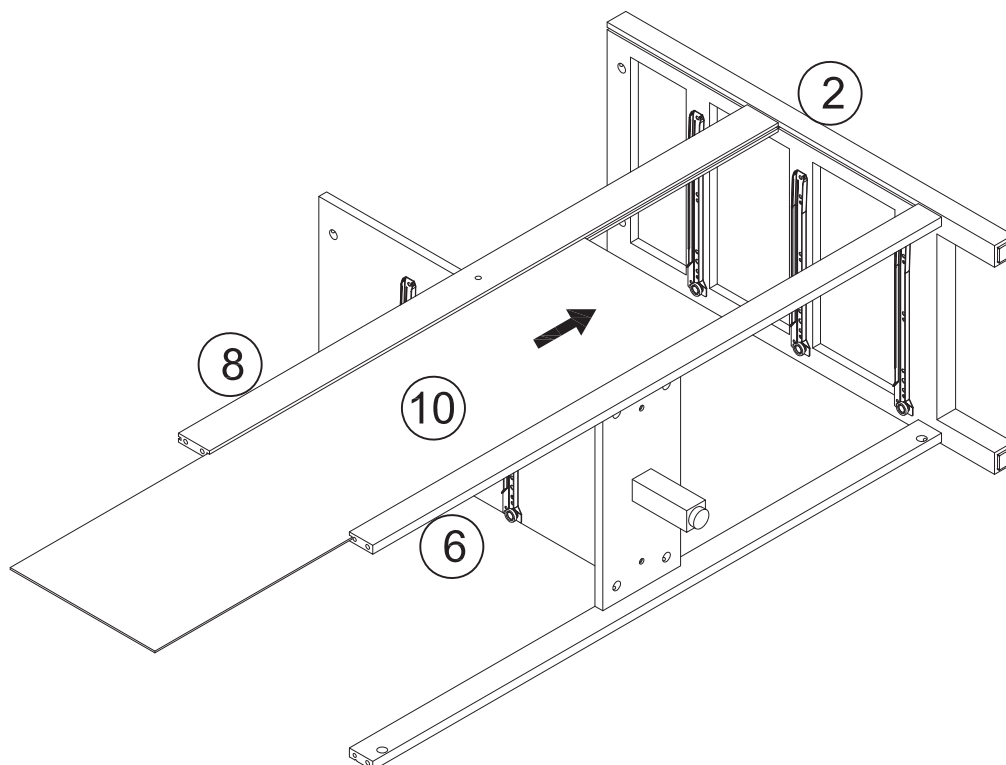

STEP 6

Insert the dowel C into part 3 first, then assemble parts 8, 6, 5 and part 3, put the eccentric B into the corresponding hole and use a flat-blade screwdriver to turn it clockwise to tighten, the installation position is as shown below.

flat-blade screwdriver

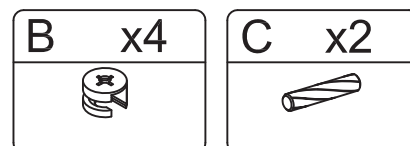
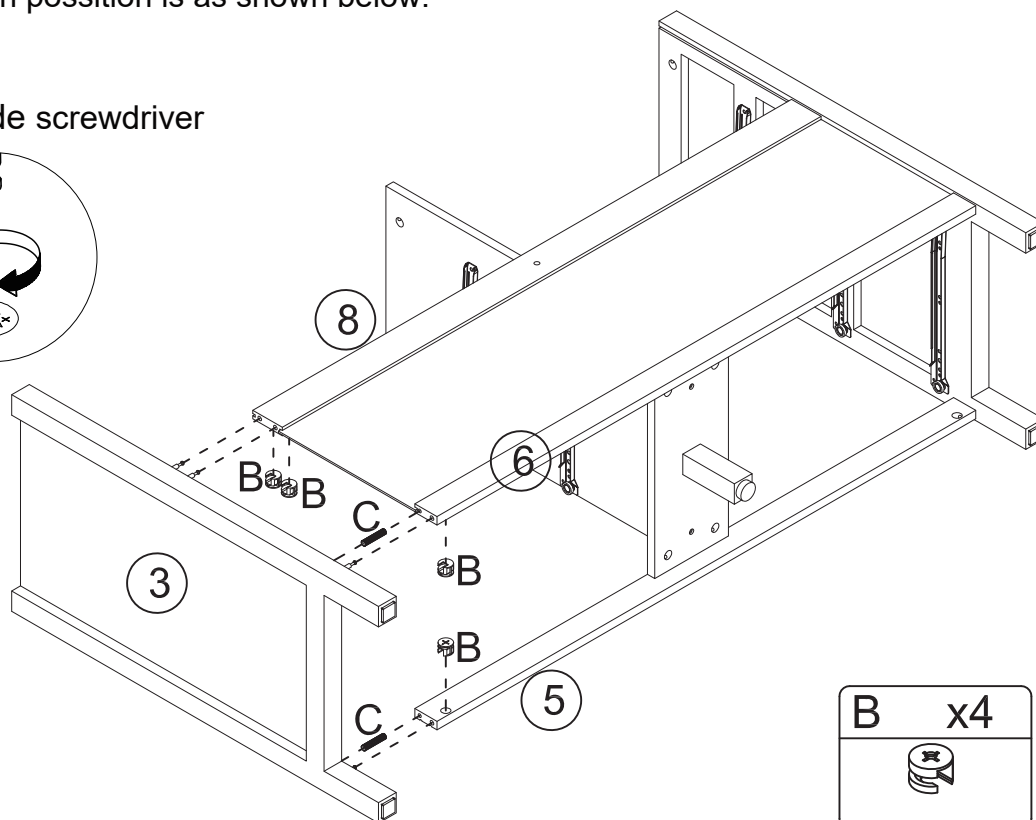
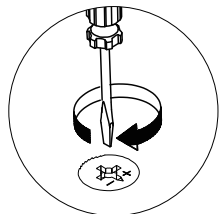

STEP 7

Insert part 9 along the slot, the position is as shown below

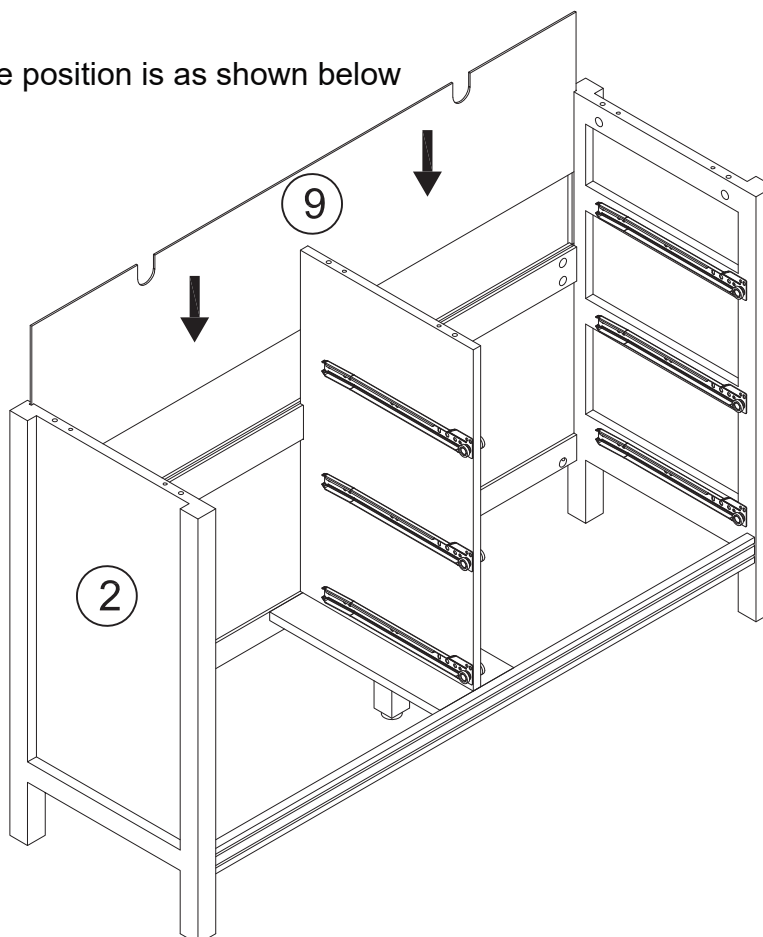





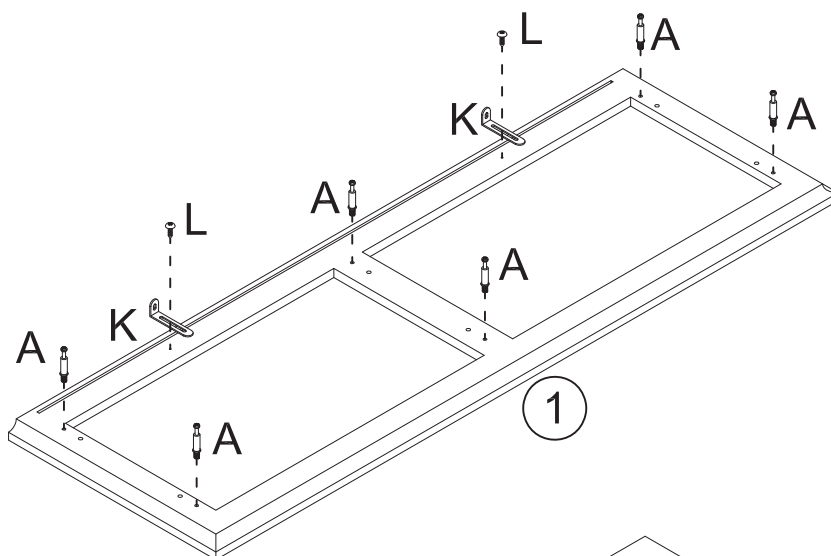

STEP 8

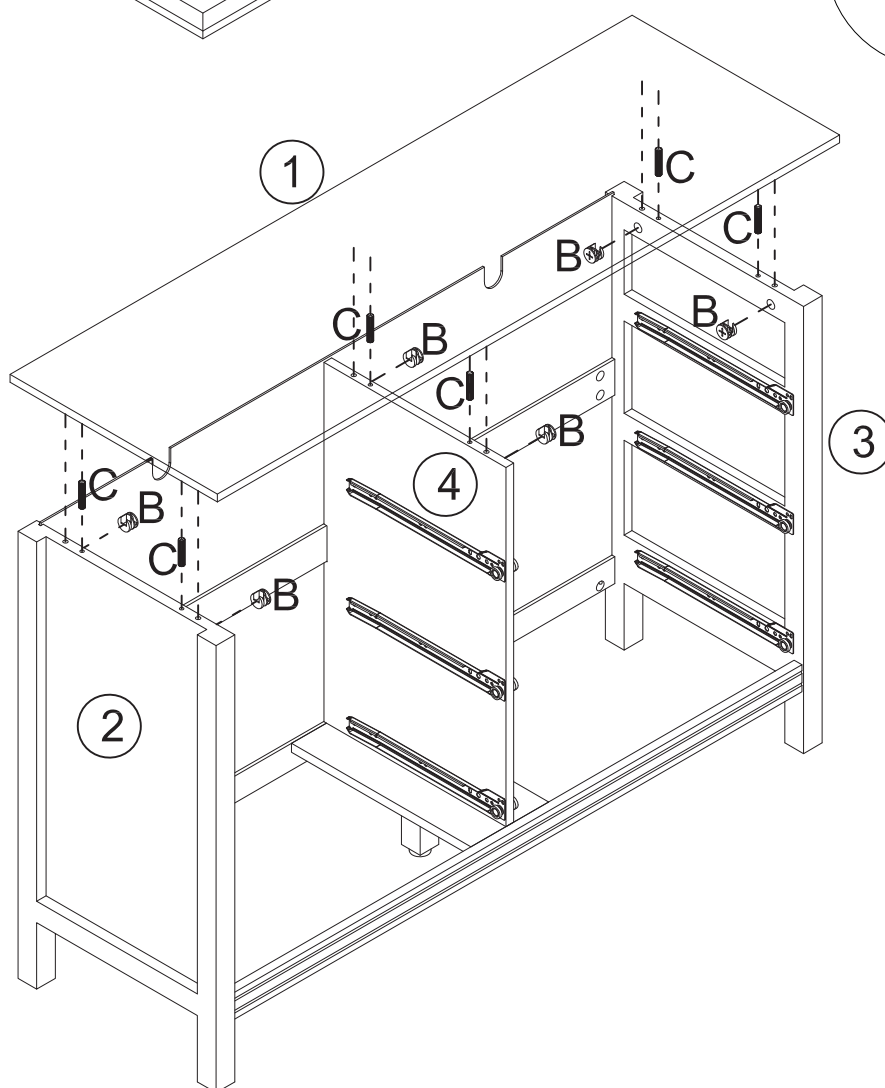
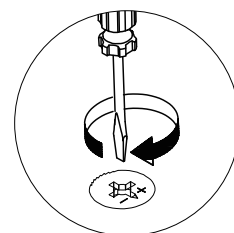
Install the screw A on the part 1, fasten the L-shaped iron piece K with screw L; Insert the dowel C into part 2,3,4, then assemble parts 2,3,4 and part 1, put the eccentric B into the corresponding hole and use a flat-blade screwdriver to turn it clockwise to tighten, the installation position is as shown below.



flat-blade screwdriver



| | | | | |
|---|---|---|---|---|
| A x6 | K x2 | L x2 | B x6 | C x6 |
|  |  |  |  |  |

STEP 9

Use the screws in component G&H to fasten the back plate buckle.
The installation position is as shown in the figure below.

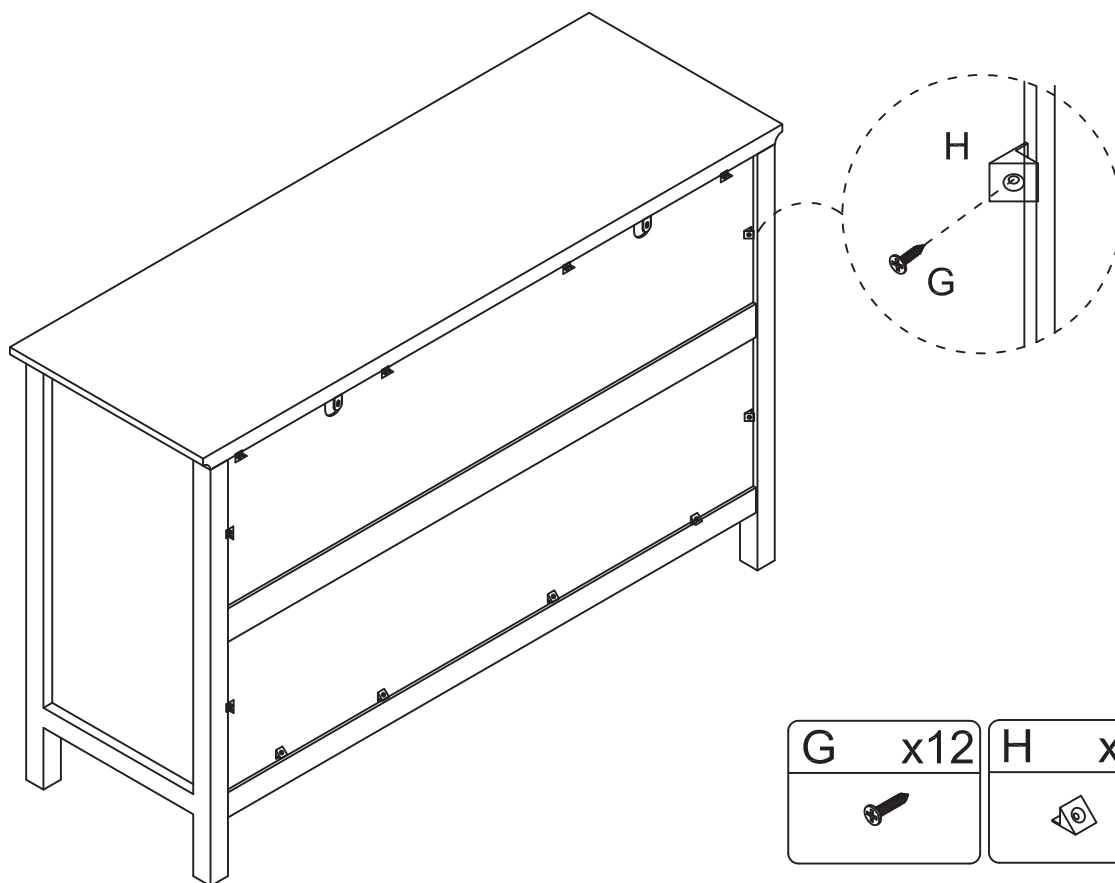

STEP 10

First drill holes on the wall where it is placed, and then use the long screw and expansion screw M to fix the cabinet with screw N.
The installation location is as shown in the figure below.

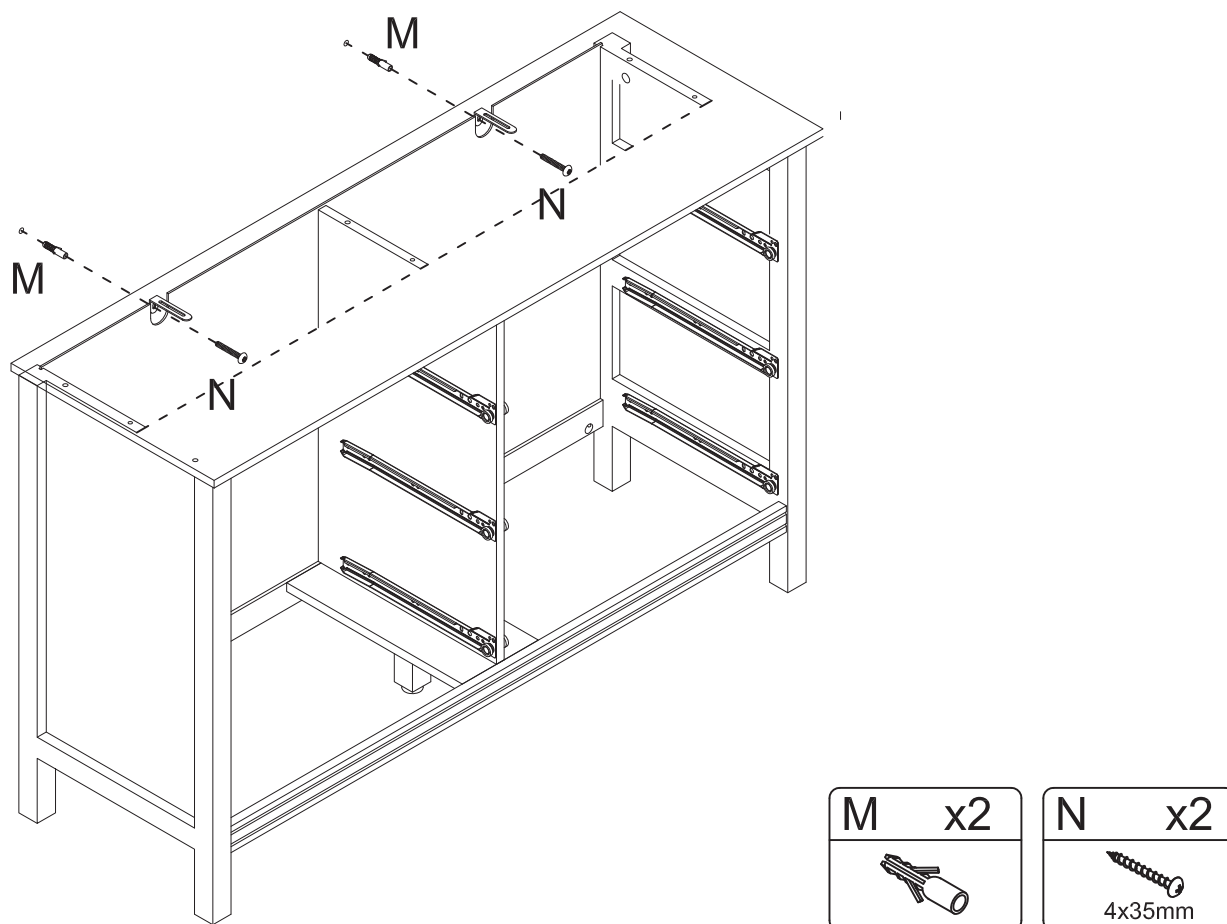

STEP 11

x 3 Install the screw A on the drawer panels 11,12 first, and then use the screw I to lock the handle J on the drawer panels 11.

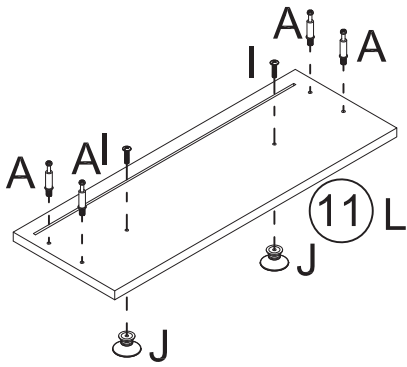

Use the screw F to assemble the side panels 13, 14 and the back panel 15.

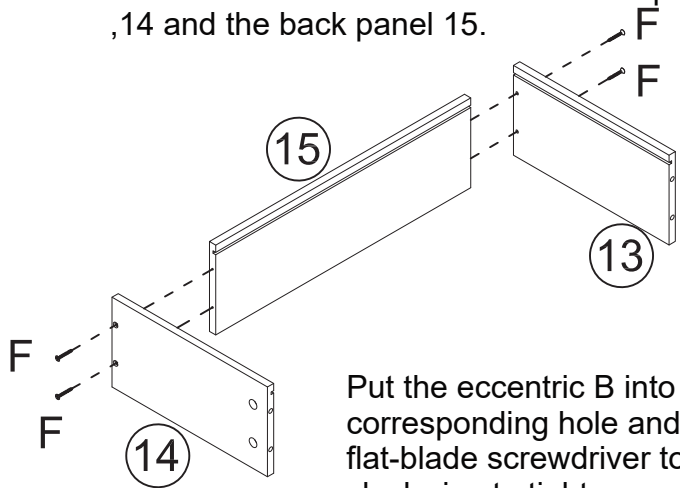

Put the eccentric B into the corresponding hole and use a flat-blade screwdriver to turn clockwise to tighten, assembly the drawer front plate 11 to the drawer.

Insert the bottom plate 16 according to the slot of side plate.

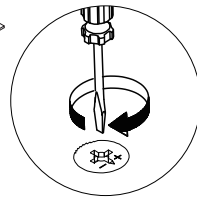
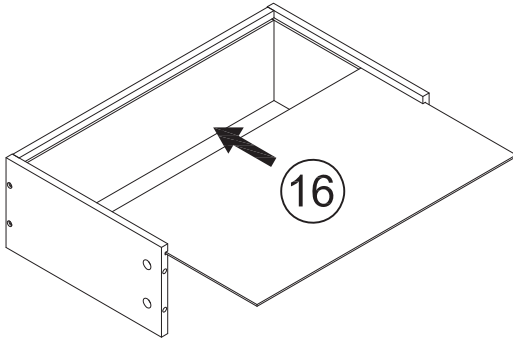

flat-blade screwdriver

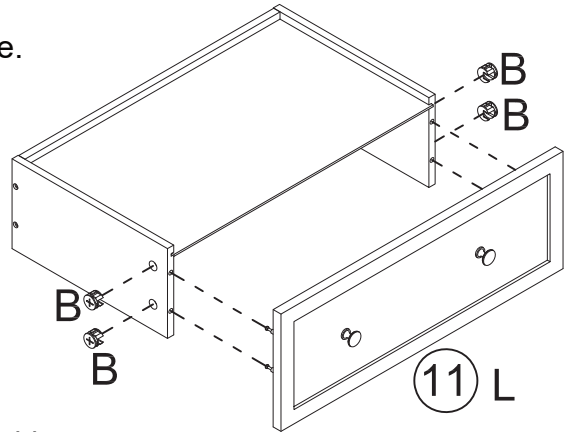

Use the screw D to install the guide rail DR on the side panel 14, and install the guide tail DL on the side panel 13. the installation position is as shown in the figure below.

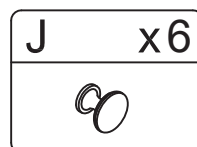
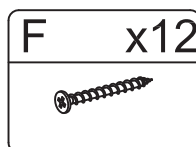
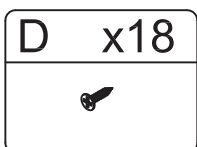
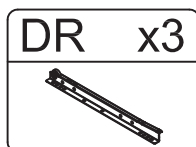
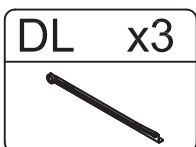
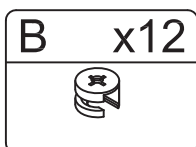
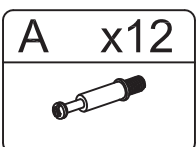
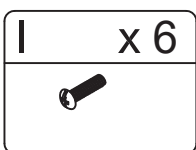
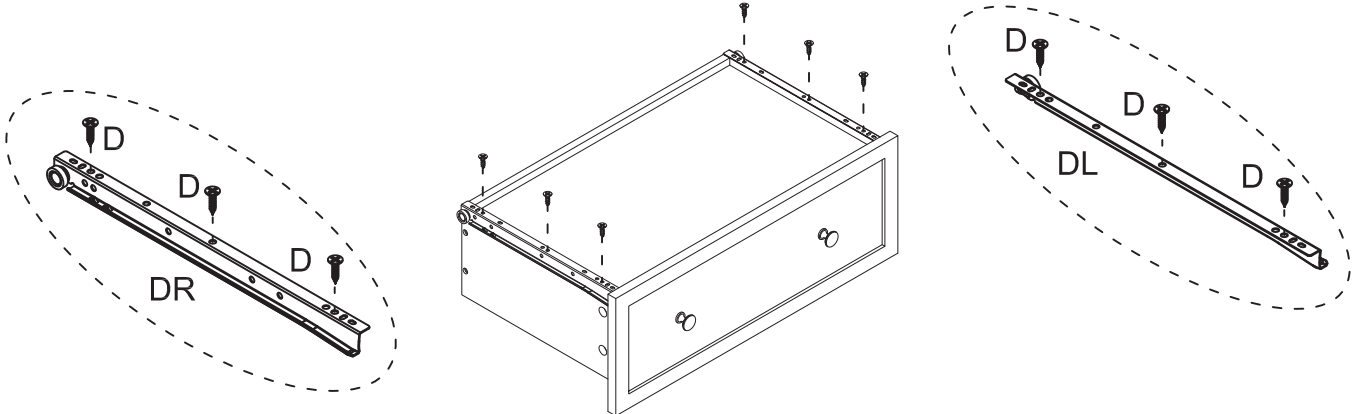

STEP 12

x 3

Install the screw A on the drawer panels 11,12 first, and then use the screw I to lock the handle J on the drawer panels 12.

Use the screw F to assemble the side panes 13,14 and the back panel 15.

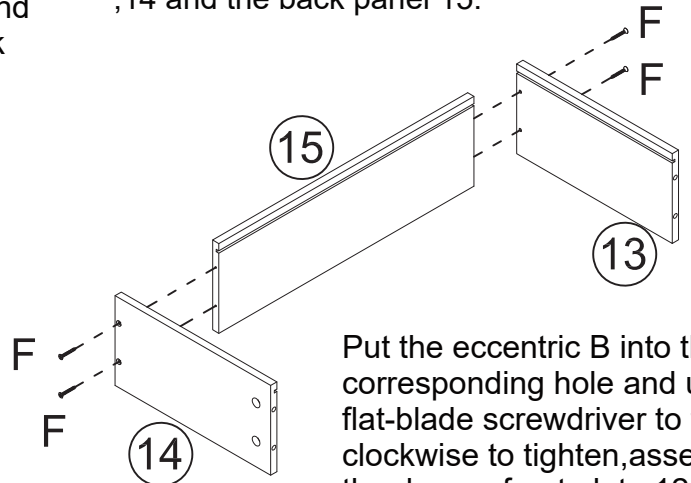
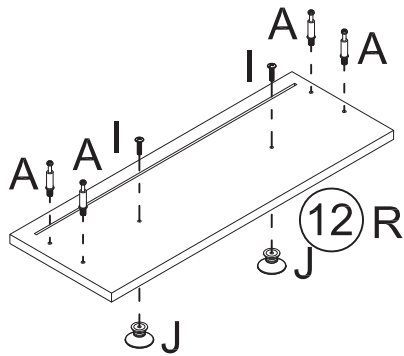

Put the eccentric B into the corresponding hole and use a flat-blade screwdriver to turn clockwise to tighten, assembly the drawer front plate 12 to the drawer.

Insert the bottom plate 16 according to the slot of side plate

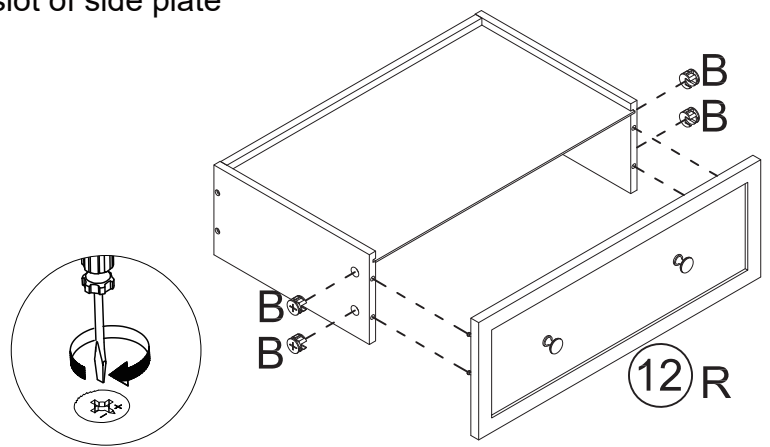
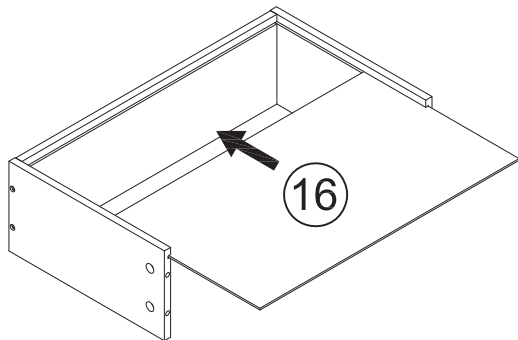

flat-blade screwdriver

Use the screw D to install the guide rail DR on the side panel 14, and install the guide tail DL on the side panel 13. the installation position is as shown in the figure below.

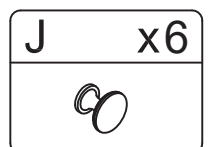
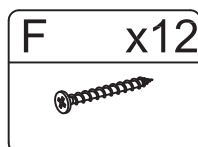
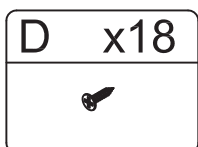
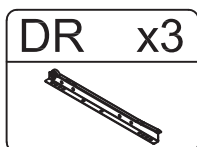
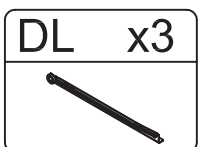
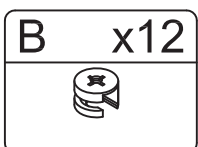
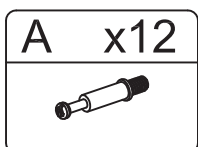
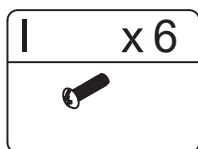
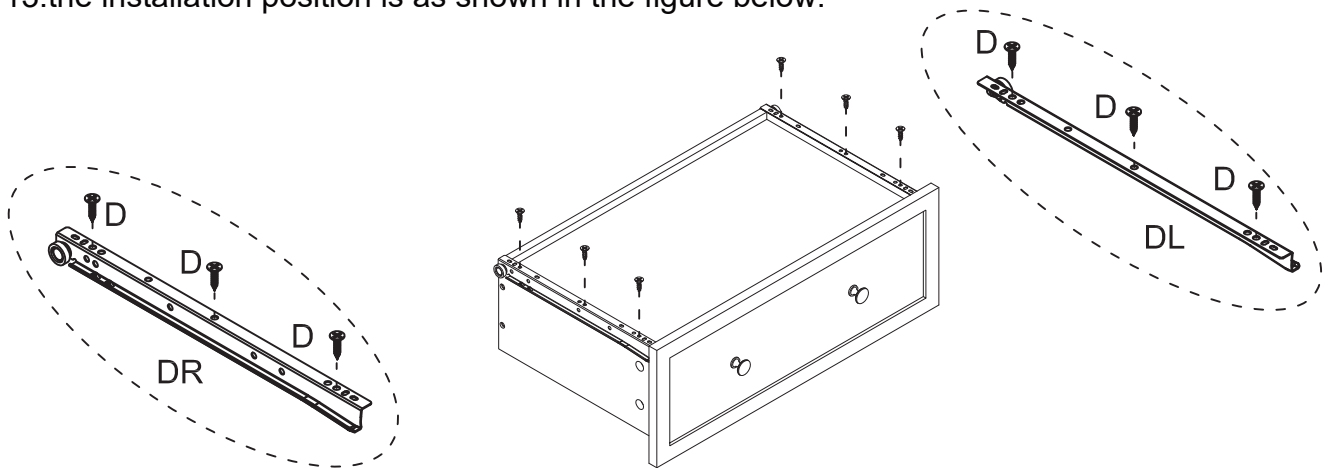

STEP 13

Install the No.11 drawer into the left drawer, and the 12 drawer into the right drawer,
The installation position is as shown in the figure below.

