

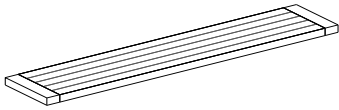

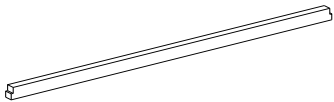

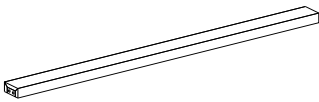
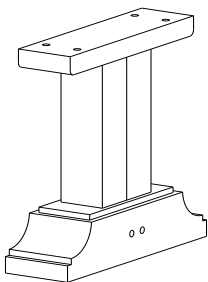
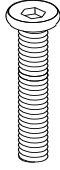
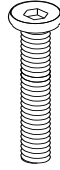

# ASSEMBLY INSTRUCTIONS

## PARTS LIST

A	BENCH TOP X 1		<p><b>Before beginning</b></p> <p>1 - Carefully unpack and position the item on a clean, non-marring surface to assemble.</p> <p>2 - Read this Assembly Instructions from beginning to end before starting to assemble.</p> <p>3 - Take an inventory of the required parts to ensure all are available.</p> <p>4 - To prevent accidental choking hazards, keep all packing materials away from small children.</p> <p>5 - Only tighten hardware until ALL hardware are fully engaged on their locations. Overtighten bolts will damage the bolt threads.</p> <p>6 - Use only factory provided hardware to assemble. Unapproved hardware can damage product or jeopardize the structural integrity of the product.</p> <p>7 - The use of power tool to assemble is not recommended due to high risk of over-torque, which can damage the product.</p>
B	TOP SUPPORT X 1		
C	STRETCHER x1		
D	LEGS X 2		

Z	HARDWARE	 <b>Z1</b> 8X80MM X 4	 <b>Z2</b> 8X50MM X 8	 <b>Z3</b> 8X19X1.6MM X 12	 <b>Z4</b> 8X12-13X2MM X 12	 <b>Z5</b> 4X59MM X 1	 <b>Z6</b> 4X40MM X 4	 <b>Z7</b> 4X9X1.5MM X 4	 <b>Z8</b> SCREWDRIVER X 1	
---	----------	---	---	--	---	---	--	--	--	--

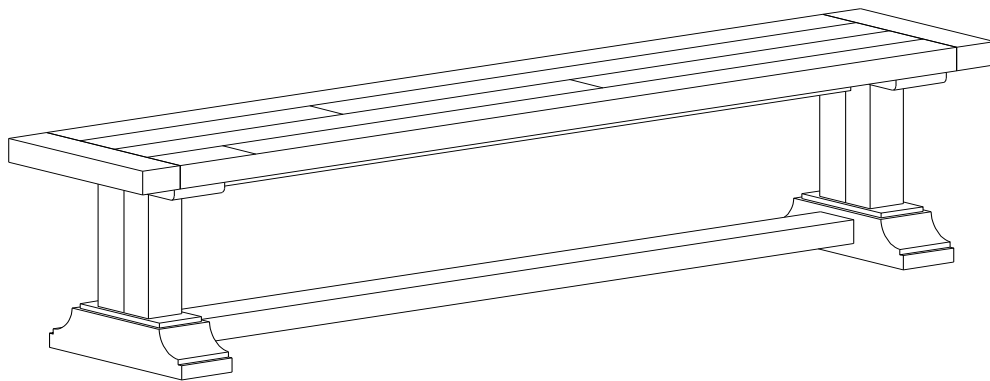

ASSEMBLY REQUIRES  
TWO PEOPLE



15-MINUTE  
ASSEMBLY TIME



KEEP INSTRUCTIONS  
FOR FUTURE USE



# ASSEMBLY INSTRUCTIONS

1

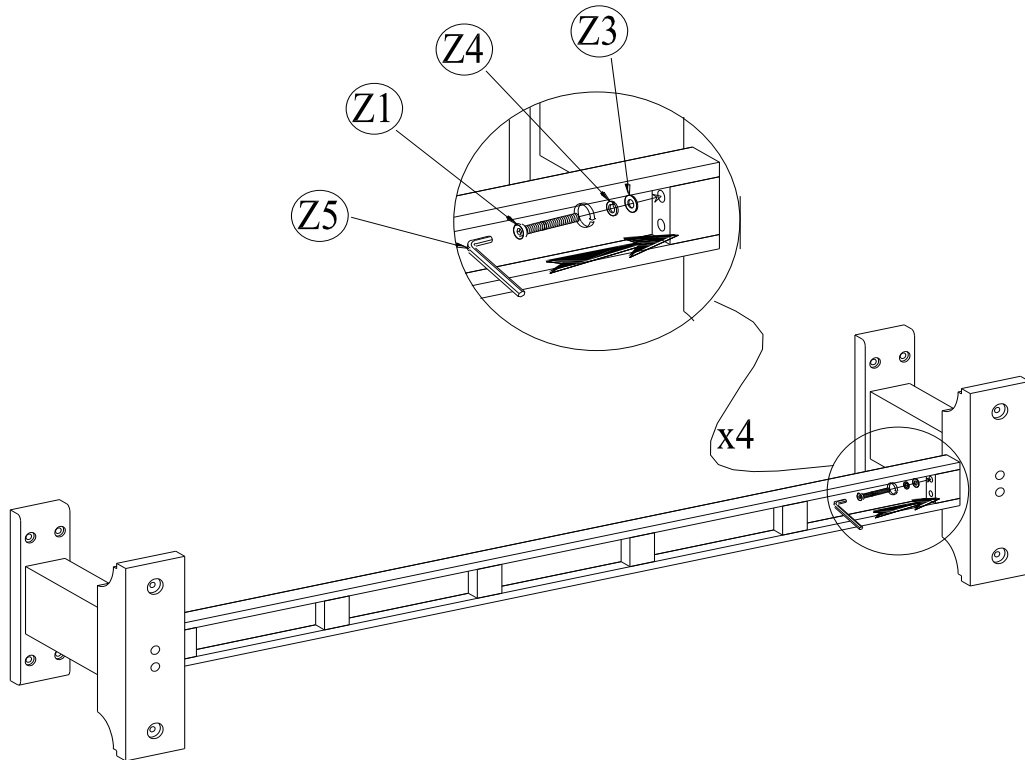

- Assemble the Stretcher (C) to the Legs (D), using Allen key (Z5) to tighten Allen Bolts (Z1), Spring Washers (Z4) and Washers (Z3).

2

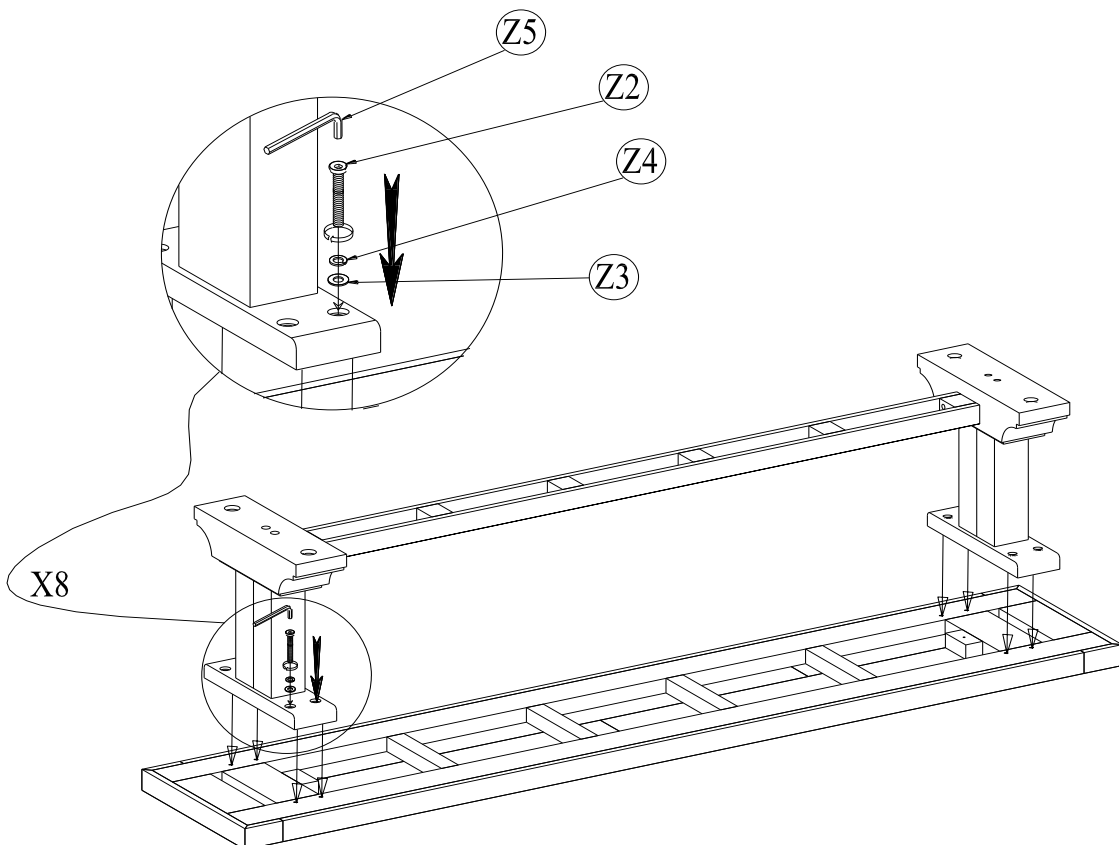

- Attach the Leg set into the Bench Top (A).  
- Using Allen key (Z5) to tighten Allen Bolts (Z2), Spring washers (Z4) and Washers (Z3).

# ASSEMBLY INSTRUCTIONS

3

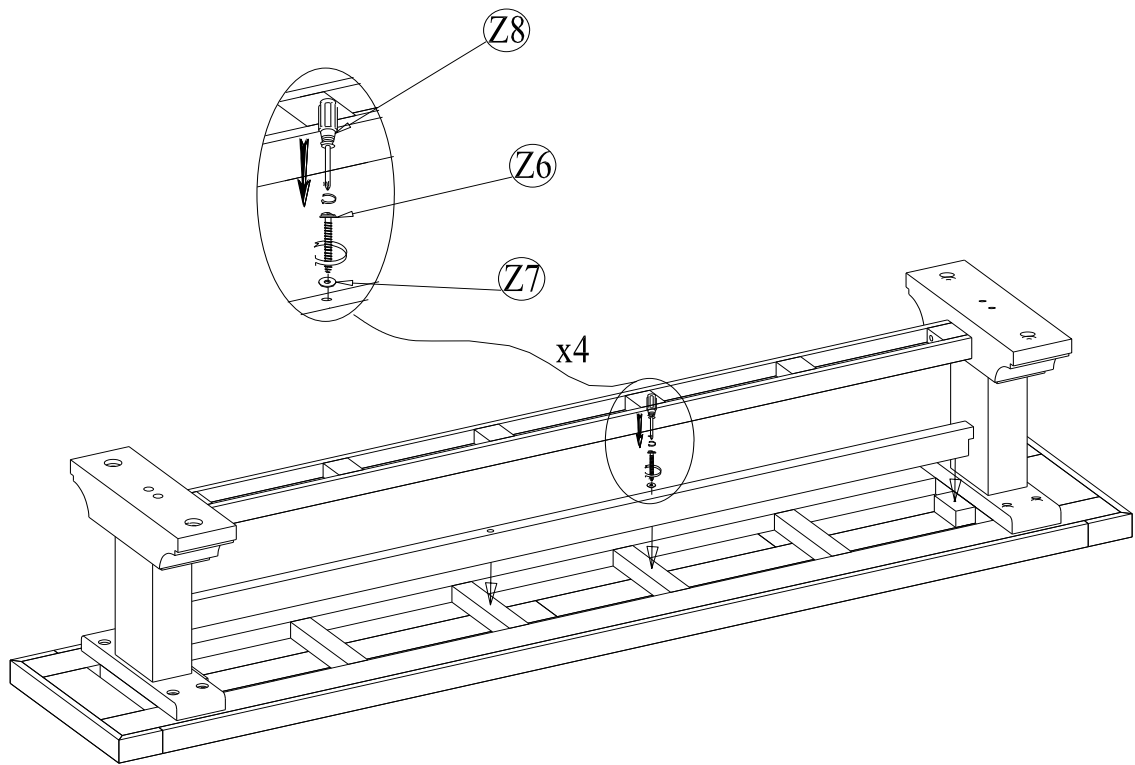

- Attach the Top Support (B) to the Bench Top (A).
- Using Screwdriver (Z8) to tighten Screws (Z6) and Washers (Z7).

4

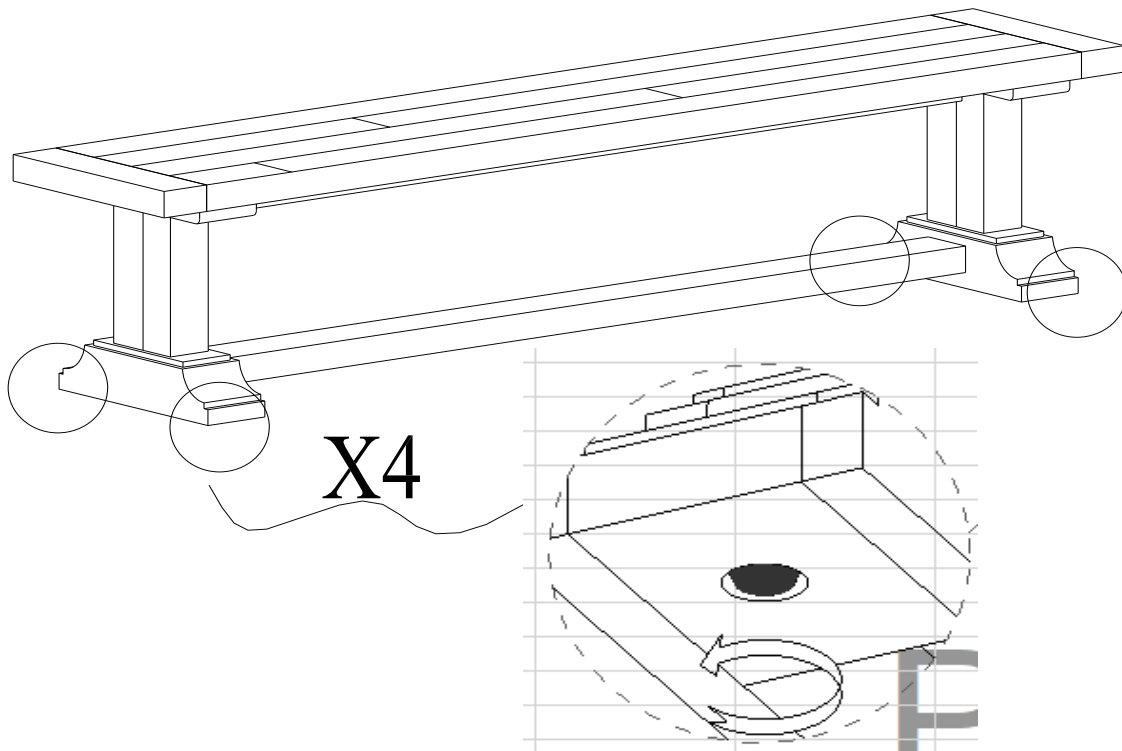

- With the assistance of two people, carefully flip the Bench over and position it on its legs.
- If the Bench is not level, make adjustments by using the adjuster floor glides beneath the legs.
- Assembly Completed