

Metal Dining Table Assembly Manual

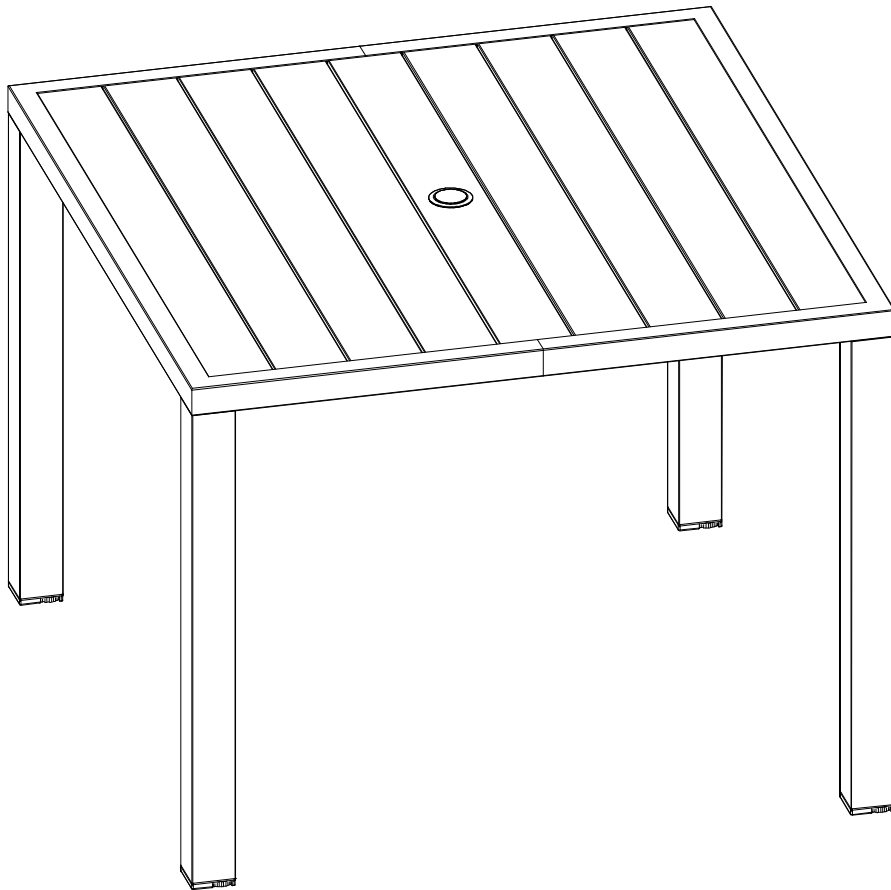

READ & SAVE BELOW

INSTRUCTIONS BEFORE ASSEMBLY

1. PLEASE SEPARATE AND IDENTIFY ALL PARTS, MAKING SURE THAT YOU HAVE ALL OF THE PARTS LISTED.
2. TO AVOID ANY SCRATCH DURING ASSEMBLY, PLEASE ASSEMBLE ON A SOFT MAT OR SIMILAR.
3. PLEASE ASSEMBLE STEP BY STEP AND FOLLOW THE INSTRUCTIONS.
4. WASHERS MUST BE USED.
5. WHILE EACH SCREW AND NUT IS PROPERLY FASTENED, DO NOT OVER FASTEN IT.

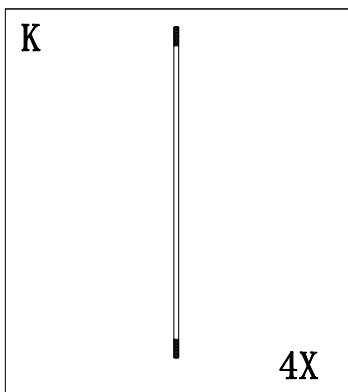
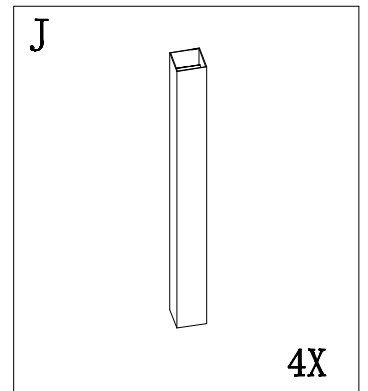
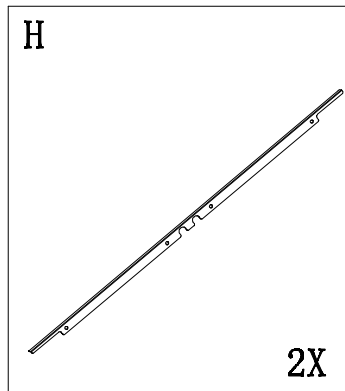
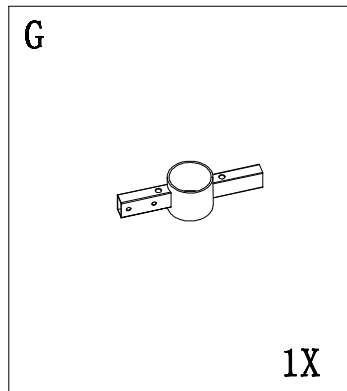
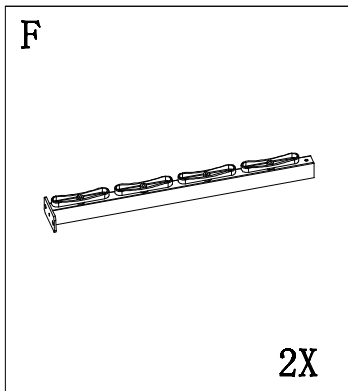
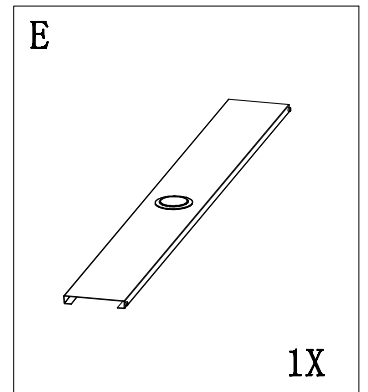
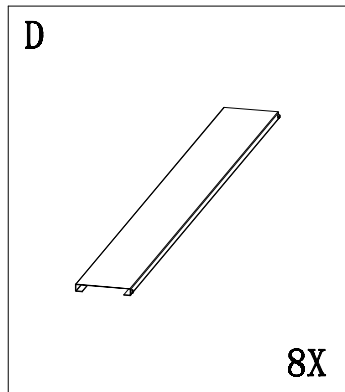
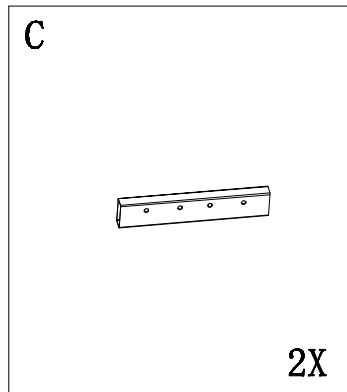
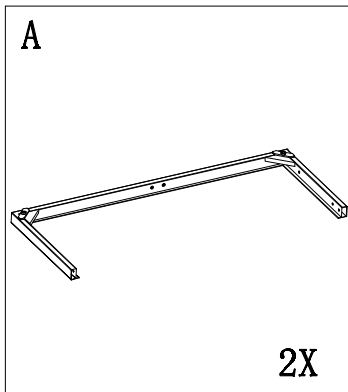

L

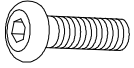

M6*15

20X

M

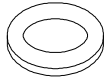

20X

N

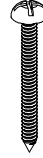

St4. 2*40

2X

O

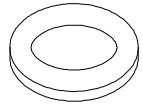

8X

P

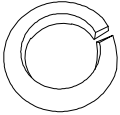

8X

Q

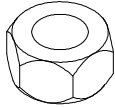

8X

R

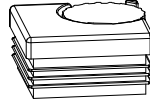

4X

S

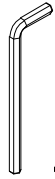

S4

1X

T

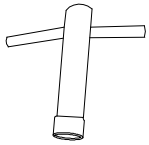

1X

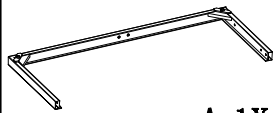

A 1X

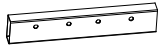

C 2X



L 2X



M 2X



S 4
1X

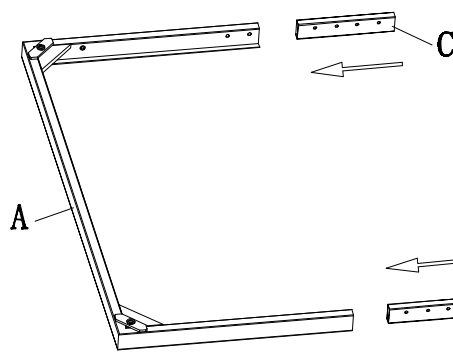

Insert Parts #C to
Parts #A as shown.

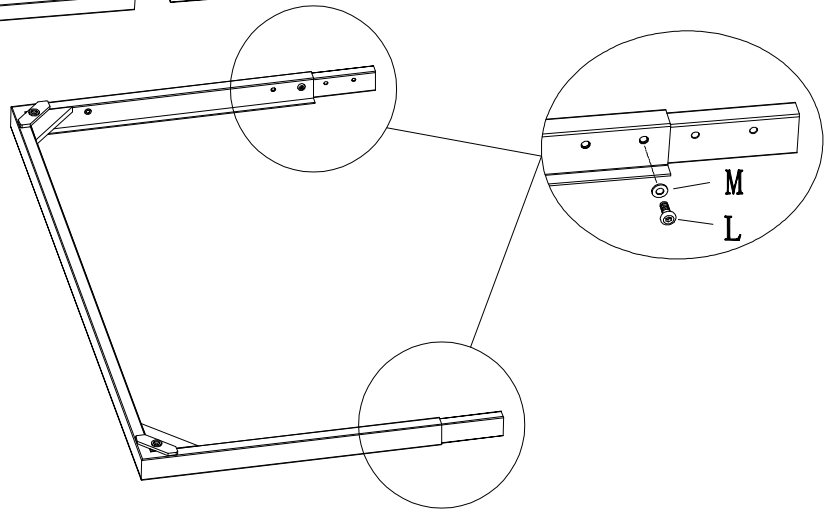

Attention: The installation hole position of the bolts #L
and washers #M should be placed as shown.



A 1X



L 2X



M 2X



S 4
1X

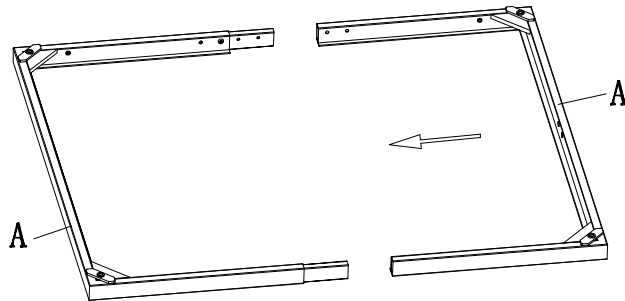

Insert Part #A into
Parts #C in the
previous step as shown.

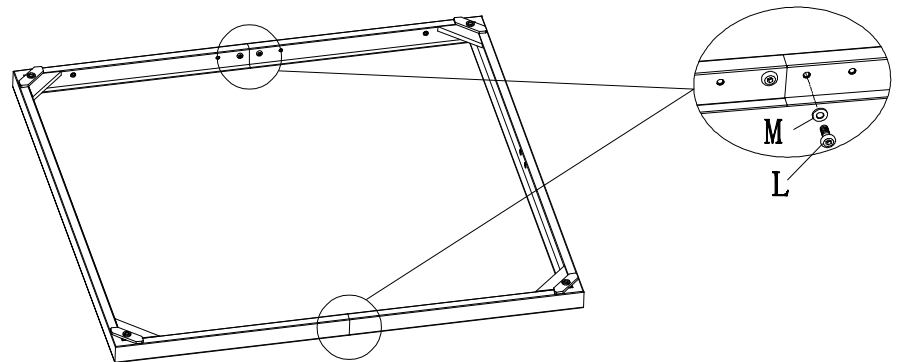

Attention: The installation hole position of the bolts #L
and washers #M should be placed as shown.

1

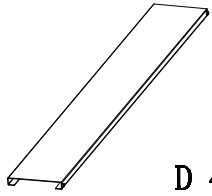

D 4X

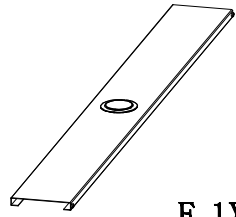

E 1X

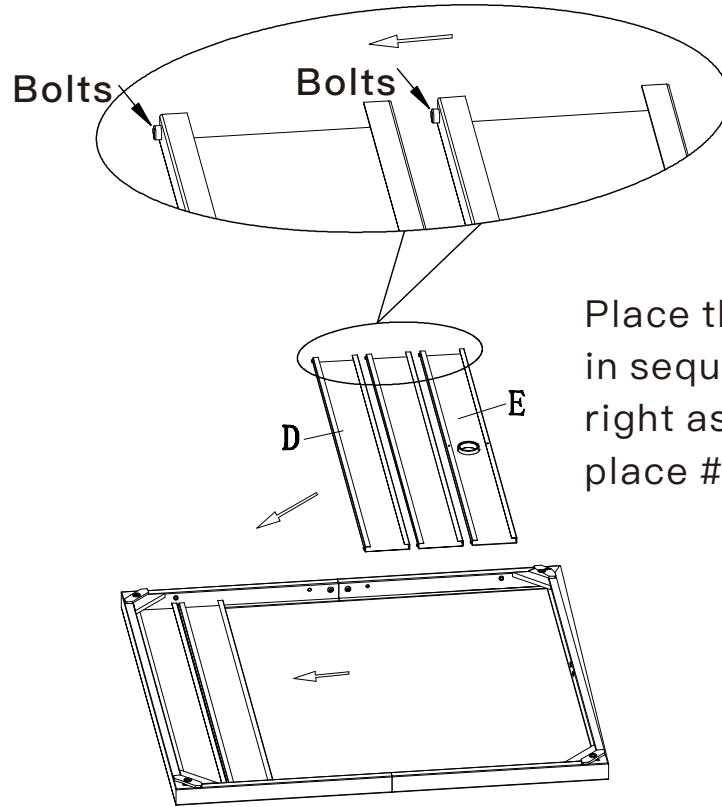

Place the tabletops #D in sequence from left to right as shown, and place #E in the middle.

Attention: the bolts on the sides of each tabletop panel should face the same direction.

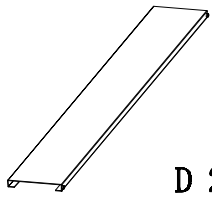

D 2X

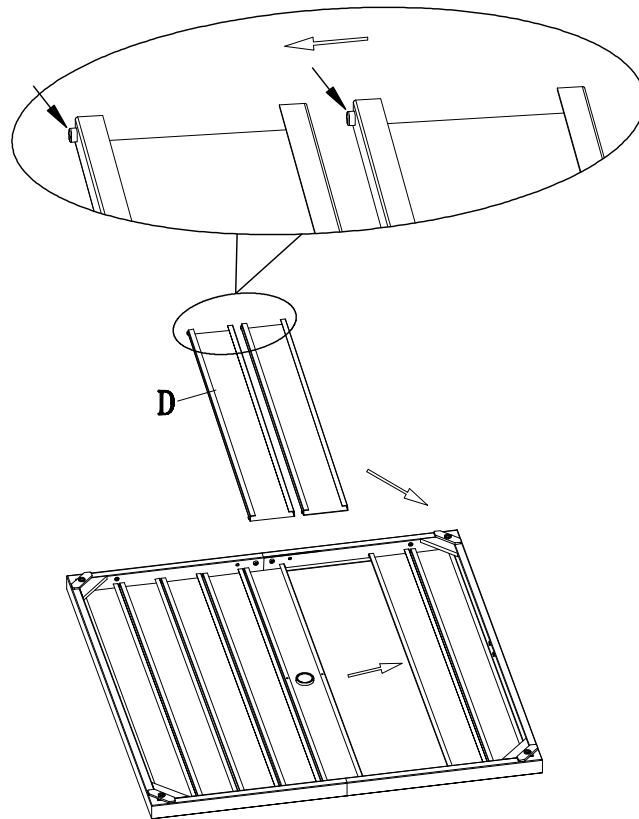

Do the tabletop panel installation for the right part the same as above.

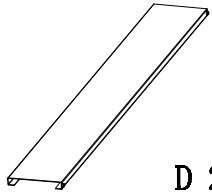

D 2X

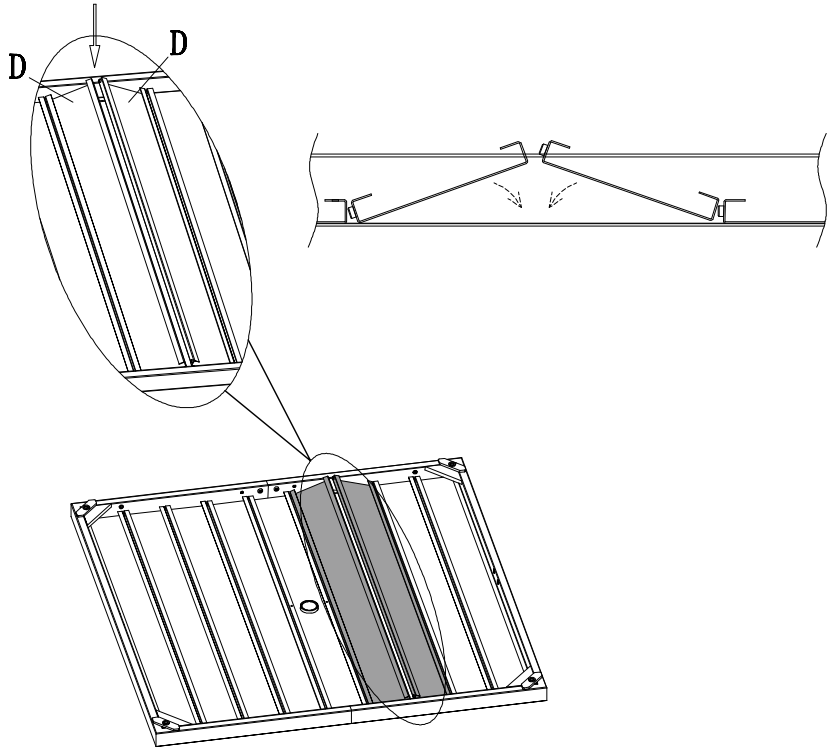

When there are the last two tabletops remaining, open them to the angle as shown for assembly.

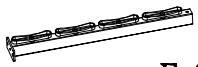

F 2X

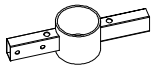

G 1X



L 4X



M 4X



S 4X
1X

Insert 2 Parts #F to Parts #G as shown.

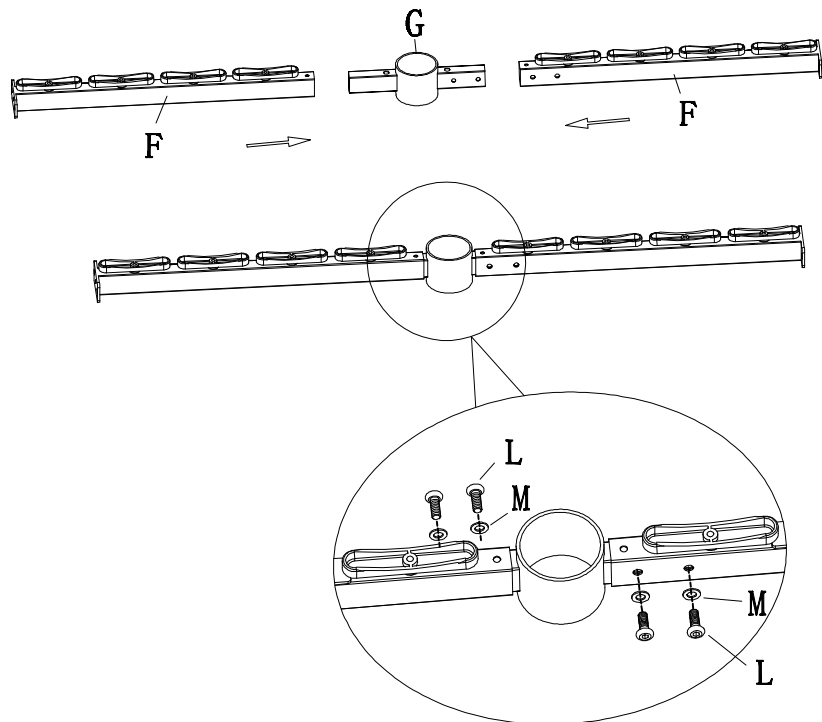

Secure the connecting rod with 4 bolts #L and 4 washers #M as shown.

3

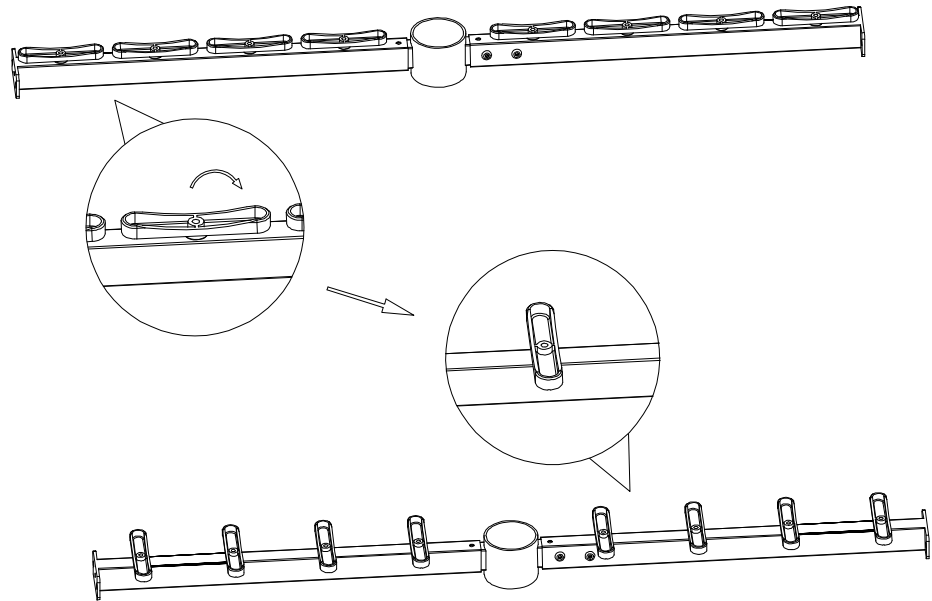

Rotate each plastic clip 90° clockwise so that it is perpendicular to the connecting rod as shown.



N 2X

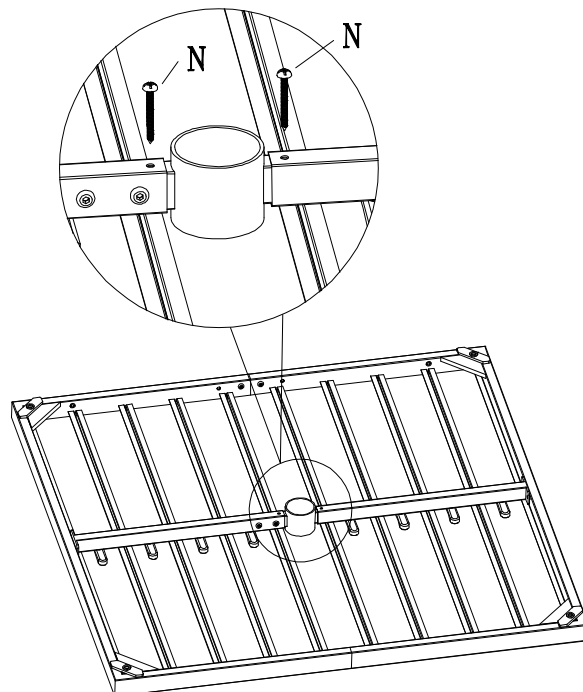

Place the connecting rod in the center of the tabletop, and tighten the 2 screws #N at the screw holes on both sides.



L 4X



M 4X



S S4
1X

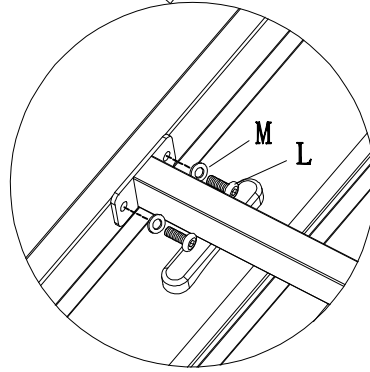
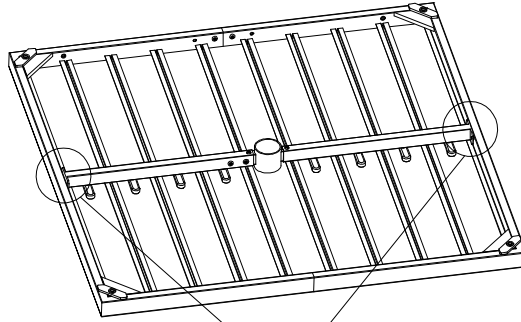

Assemble tabletop to the connecting rod with washers #M and bolts #L.

After all screws are assembled in place, tighten them together as shown.

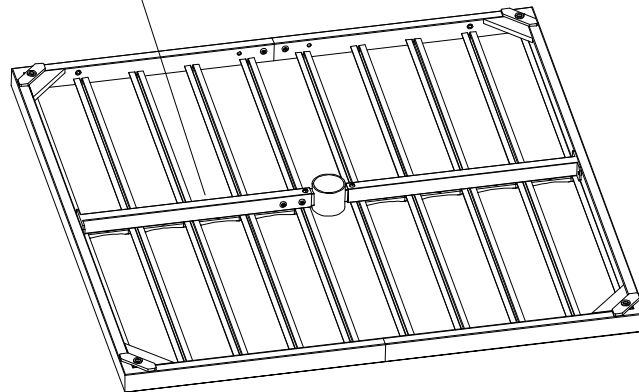
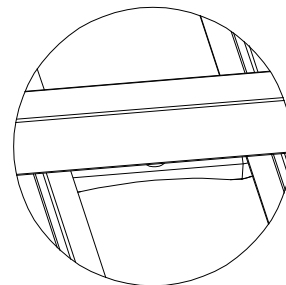
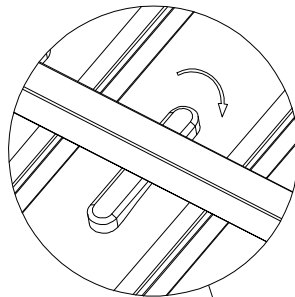

Rotate each plastic clip for 90° to reset as shown.

5

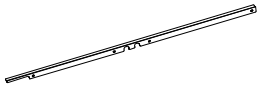

H 2X



L 8X



M 8X



S S4
1X

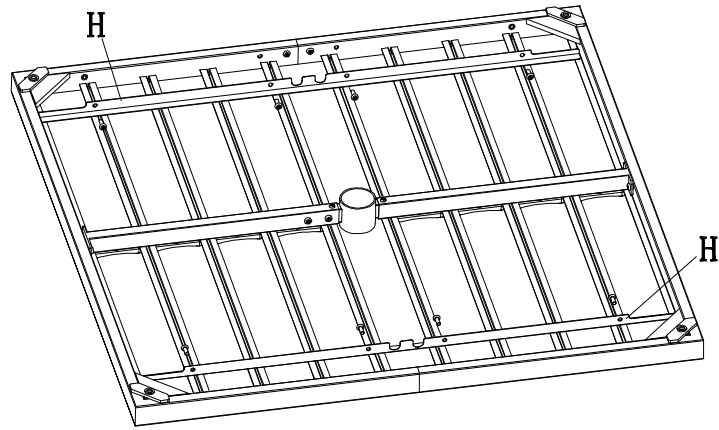
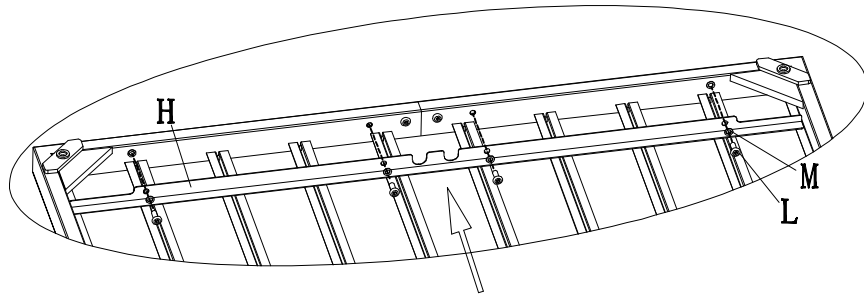

(1) Place Part #H as shown, noting that the narrower side inserts outward.

(2) Insert bolts #L and washers #M into the hole positions as shown. After all screws are assembled in place, tighten them together.

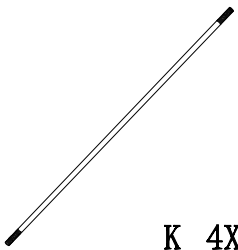

K 4X



O 4X



P 4X



Q 4X

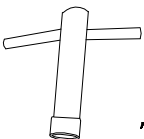

T 1X

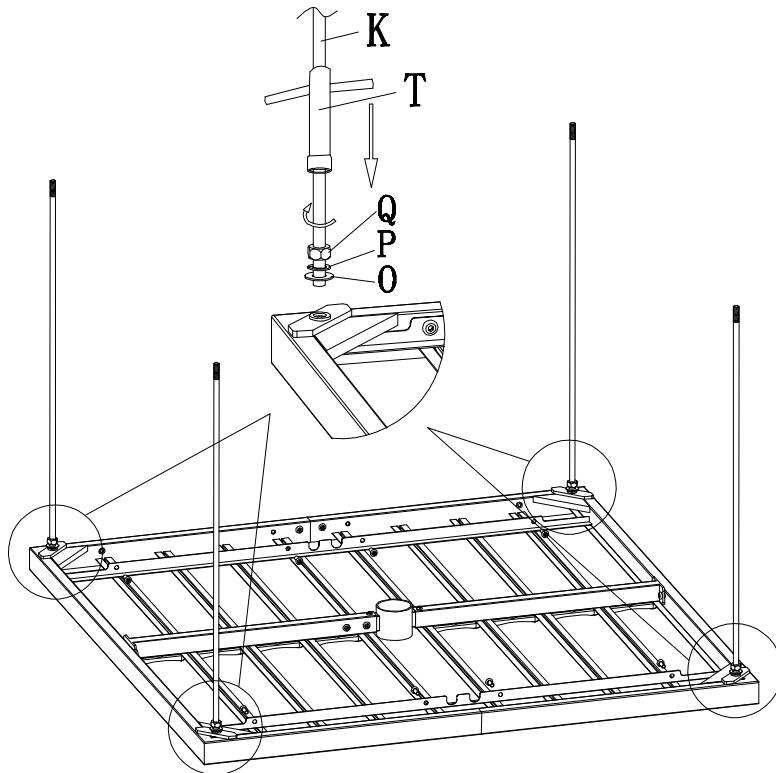

(1) Insert washers #O, spring washers #P and nuts #Q into Part #K as shown.

(2) Align Part #K with the hole position, twist it by hand until it cannot be turned.

(3) Tighten Part #K with #T. (The remaining tie rods #K follow same step as above.)

6

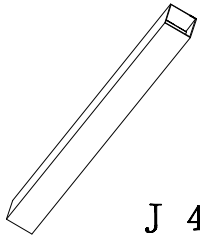

J 4X



O 4X



P 4X



Q 4X

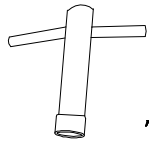

T 1X

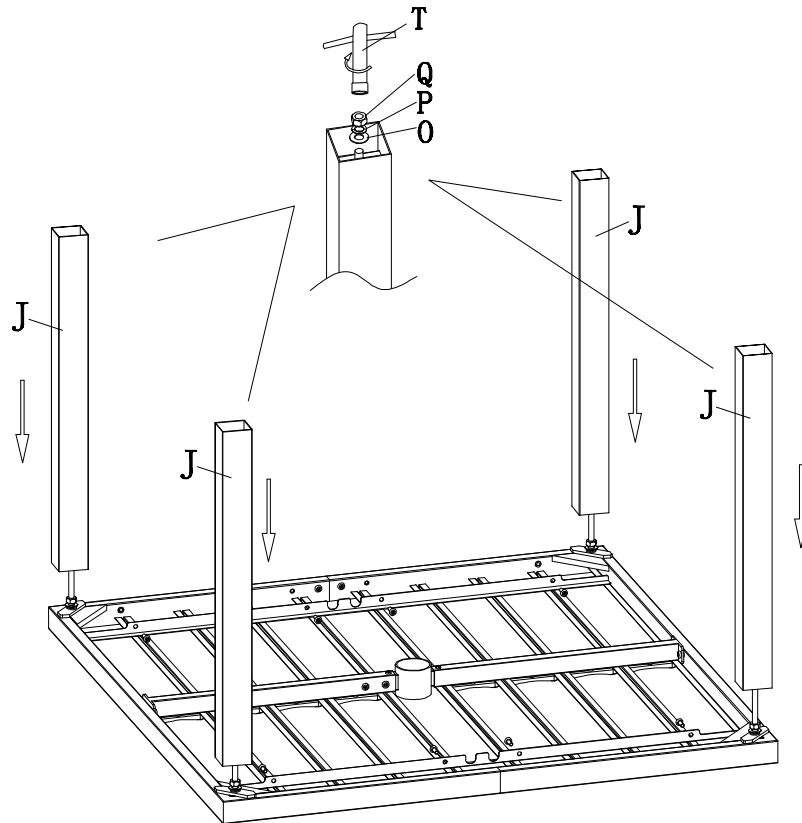

- (1) Set legs #J into #K, then set washers #O, spring washers #P and nuts #Q on #K.
- (2) Tighten with #T. (The remaining legs #J follow same step as above.)

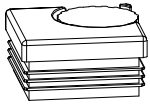

R 4X

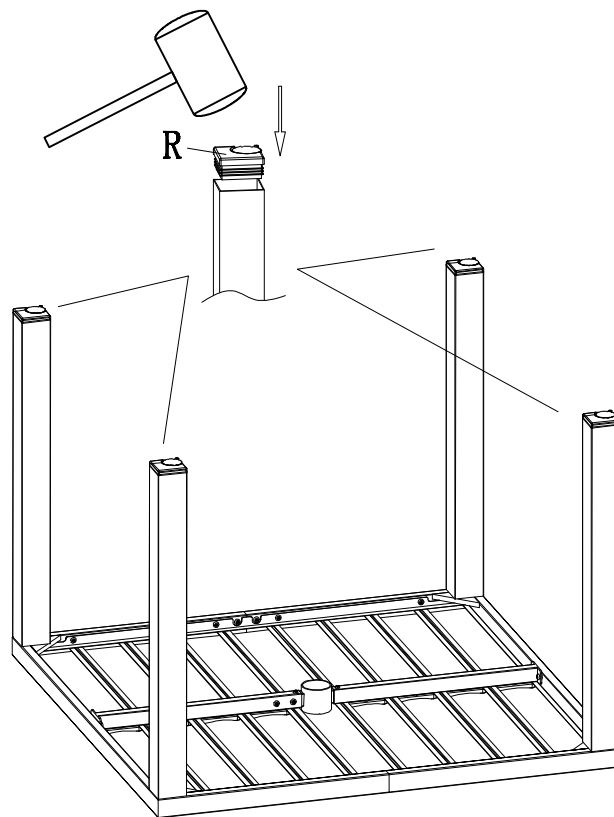

Put adjustable foot pads #R into legs #J and press it with a hammer.

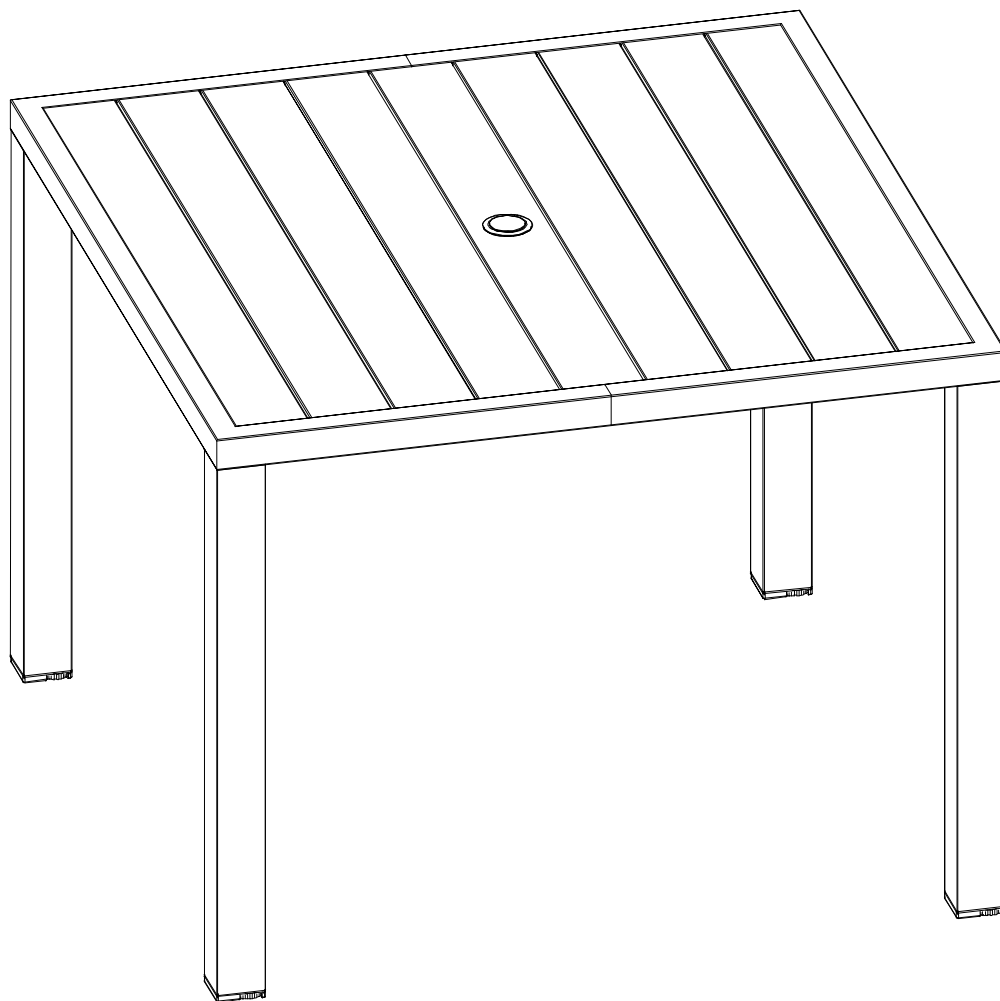

Thanks for your purchase.

We believe in our products.

That's why we provide a 12-month warranty and friendly, easy-to-reach after-sales service. So if you have any questions about our product and assembly please feel free to contact us. We will be here for you.

Please tell us your order ID when contact.

Attach photos of damaged part for instant reply.