

OPEN BED FRAME

QUEEN

ASSEMBLY INSTRUCTIONS

Before assembling your bed frame, please read through these instructions carefully and familiarize yourself with the different parts.



PARTS LIST

①	FOOT RAIL	1 PC
②	LEFT LEG	1 PC
③	RIGHT LEG	1 PC
④	SIDE RAILS	2 PCS
⑤	SLAT KIT	2 SETS
⑥	SLAT SUPPORT 1	1 PC
⑦	SLAT SUPPORT 2	1 PC
⑧	SUPPORT LEGS	3 PCS

HARDWARE

ⓐ	JCB M6 X 110mm (4 3/8") - 2 pcs Spare - 1 pc	ⓔ	JCB M6 X 25mm(1") - 6pcs
ⓑ	Barrel nut - 2 pcs	ⓕ	Cap nut - 6pcs
ⓒ	JCB M8 X 15mm (5/8") - 4 pcs	ⓖ	Allen Screw - 3pcs
ⓓ	Wood screw(1 1/4") - 29 pcs Spare - 2 pcs	ⓓ	Allen wrench M6 - 1pc
		ⓓ	Allen wrench M4 - 1pc Spare - 1pc

NOTE: WE INCLUDE SPARE HARDWARE IN CASE DAMAGE OCCURS DURING ASSEMBLY.

Step 1

Attach the legs (2) and (3) to foot rail (1), using JCB M6 X 110mm (A) and barrel nut (B).
Tighten with the Allen wrench M4 (I).

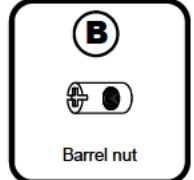
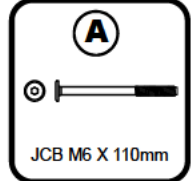
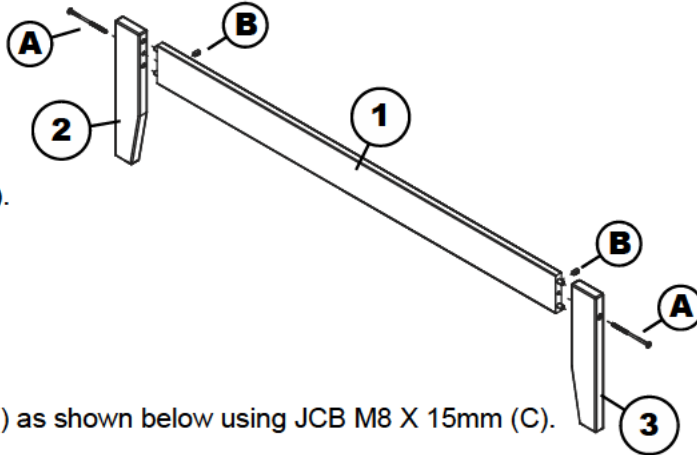

Step 2

Attach side rails (4) to the foot rail (1) as shown below using JCB M8 X 15mm (C).
Tighten with Allen wrench M6 (H).

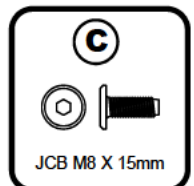
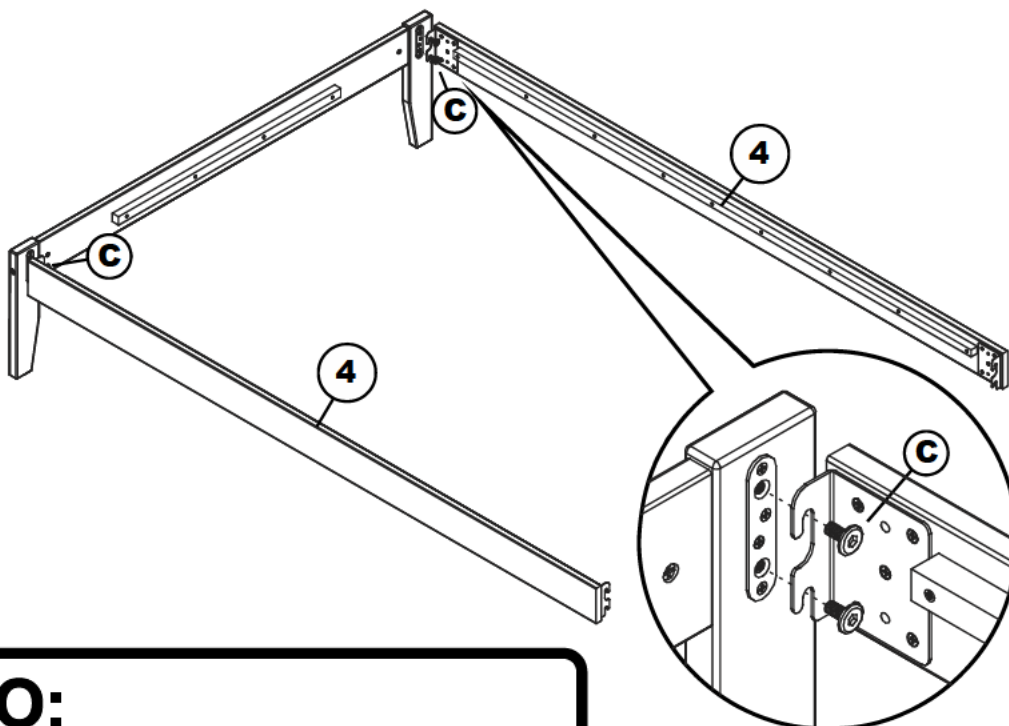

PO:

OPEN BED FRAME

QUEEN



Step 3

Attach open bed frame to the headboard as shown below using 4 JCB M8 X 15mm bolts that are supplied with your headboard. Tighten with the Allen wrench M6 (E).

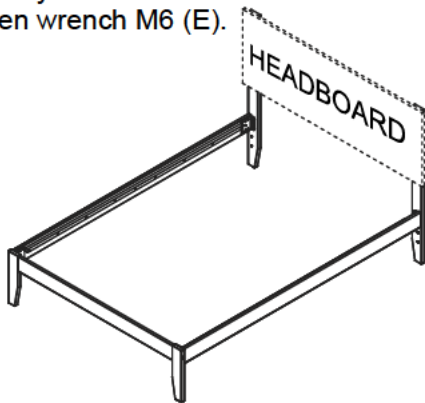
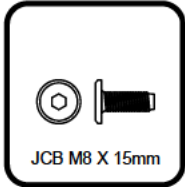

Step 4

Attach support legs (8) to slat support 1 & 2 (6)(7) as shown below. Using allen screw (G) tighten with Allen wrench M4 (I).

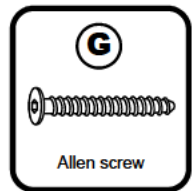
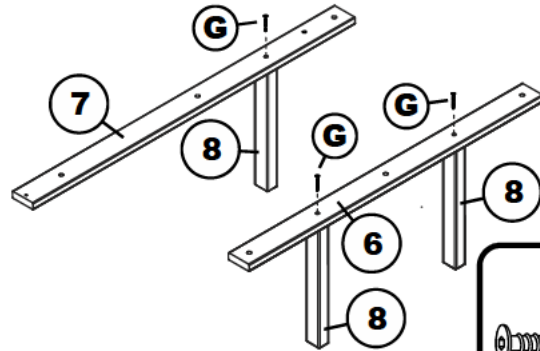

Step 5

Attach slat support 1(6) and slat support 2 (7) to the slat kit (5) as shown below using JCB M6 X 25mm (E) and cap nut (F). Tighten with Allen wrench M4 (I).

2 legs at headboard section.

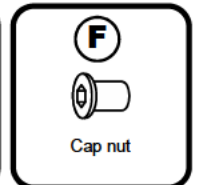
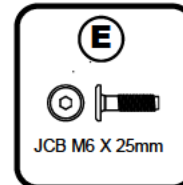
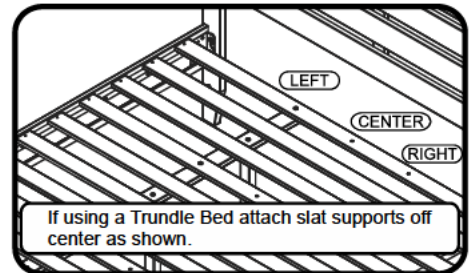
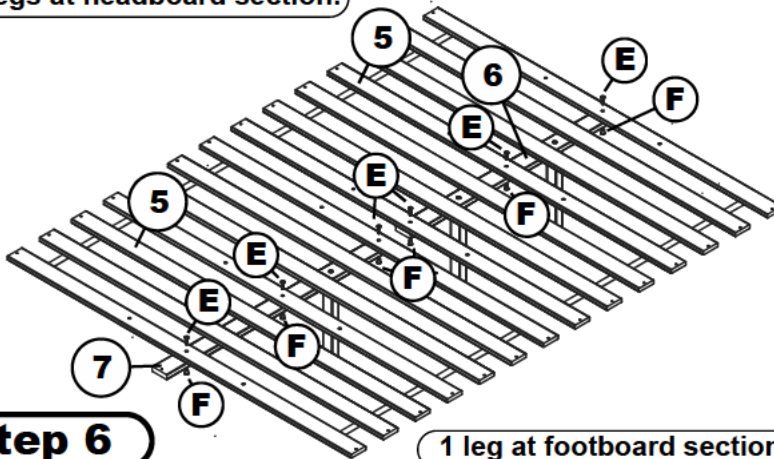

Step 6

Attach 2 slat kits (5) to the open bed frame as shown below using wood screws 1 1/4" (D). Tighten with Phillips head screw driver. (customer supplied)

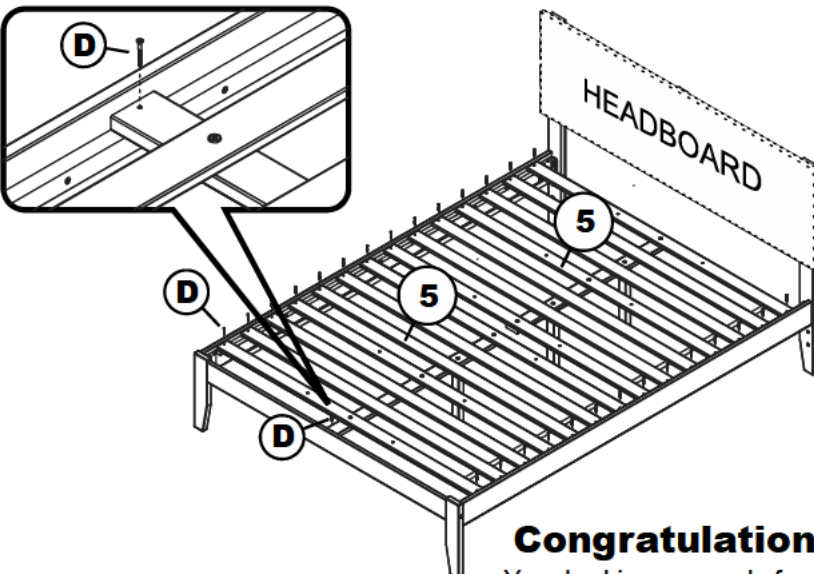

Congratulations!

Your bed is now ready for use.

We recommend that you periodically recheck that all screws are tight to ensure lasting safety.