

NOTICE

- * Please make sure that you have all parts indicated and they are in good condition before you begin assembly of this item. Refer to part list and hardware list below for guidance.
- * This item should be assembled on a soft surface to prevent scratching the finish during assembly.
- * This item may require periodic tightening
- * If you are having difficulty, our friendly Customer Care team is always here to help.

PREPARATION

- * Before beginning assembly of product, make sure all parts are present. Compare parts with part contents list and hardware contents list.
- * If any part is missing or damaged, do not attempt to assemble the product.
- * Estimated assembly time : **20 minutes**
- *Tools required for assembly (included) : **Allen key**
- *Tools required for assembly (not included) : **Philip screw driver**
- *Tools required for assembly (not included) : **Mallet**

CARE AND MAINTENANCE















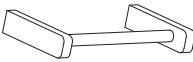

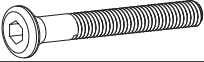

Always use felt pads under all articles to prevent discoloration or softening of the lacquer. Plastic and rubber bases on items can discolor wood. Wipe up spill immediately and avoid common hazards such as hot dishes, harsh solvents and abrasives. Cleaning should be done with a soft lint free cotton cloth dampened with water or furniture polish. On highly used surface we recommend applying a quality paste wax which should be used on a regular basis to provide additional protection from scratches and spills. How often you apply the wax depends on how much wear the furniture receives.

Product Dimensions : 38.97" W x 17.71" D x 36.22" H



WARNING
Weight capacity - 55 LBS
Warning : Do not stand on trolley.
Warning : Do not over torque bolts.

Part List and Hardware List

PIECE	DESCRIPTION	PICTURE	QUANTITY
A	Top Panel		1x
B	Leg Frame L		1x
C	Leg Frame R		1x
D	Drawer Unit		1x
E	Handle Bar		1x
F	Shelf Panel		2x
G	Back Panel		1x
H	Apron 1		1x
I	Apron 2		3x
HW 1	Jcbc Bolt M6x0.5x40mm		2x
HW 2	Jcbc Bolt M6x0.5x60mm		12x
HW 3	Barrel Nut		10x
HW 4	Silver Metal Knob		2x
HW 5	Truss Screw 20mm		2x
HW 6	Wood Button		12x
HW 7	Caster Wheel		4x
HW 8	Wood Dowel M8 x 30mm		8x
HW 9	Allen Key M4		1x
HW 10	Spanner 13		1x

PREPARATION

- * Before beginning assembly of product, make sure all parts are present. Compare parts with part contents list and hardware contents list.
- * If any part is missing or damaged, do not attempt to assemble the product.
- * Estimated assembly time : 20 minutes
- * Tools required for assembly (included) : Allen key
- * Tools required for assembly (not included) : Philip screw driver
- * Tools required for assembly (not included) : Mallet
- * If you are having difficulty, our friendly Customer Care team is always here to help.

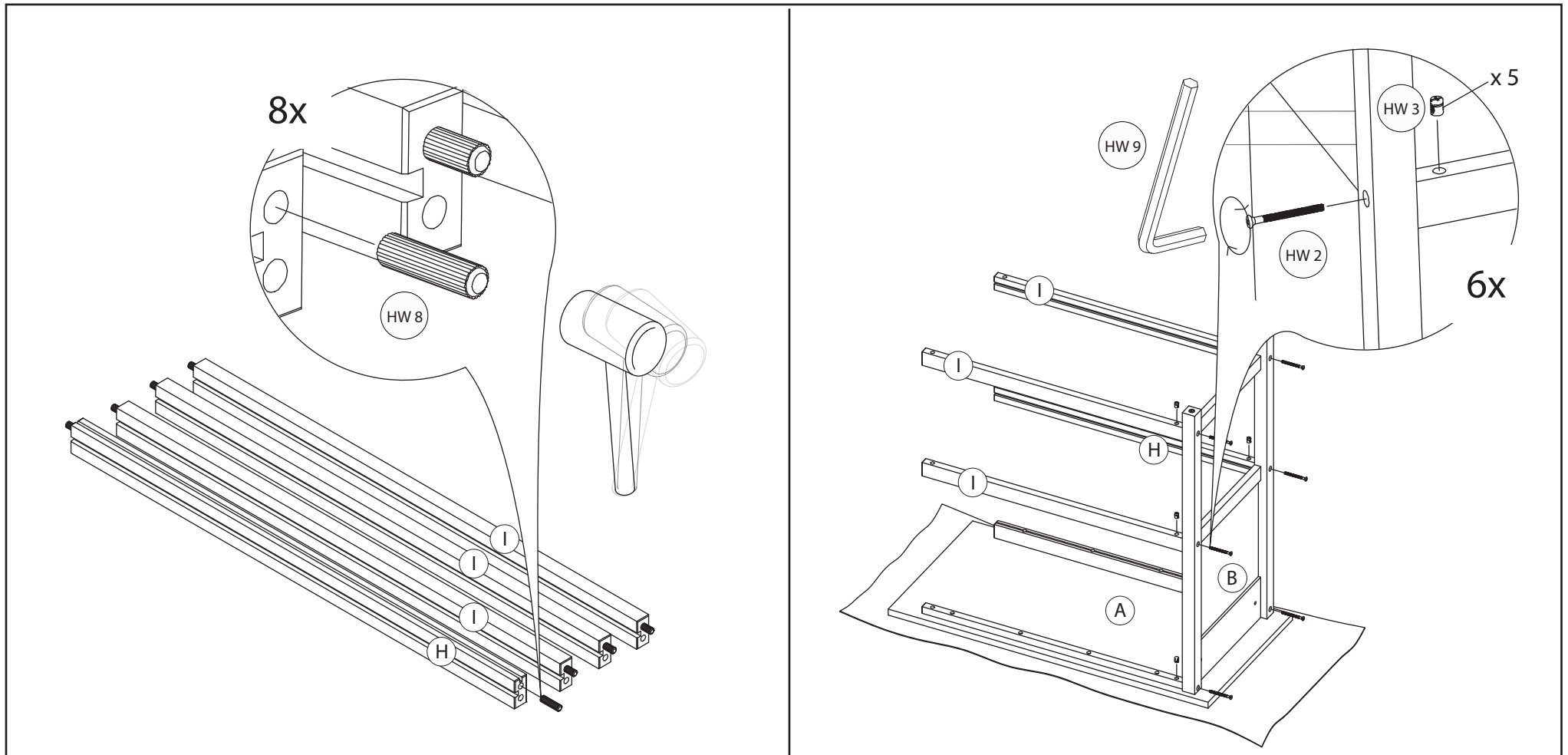

Step 1 : Insert the wood dowel (HW8) to the hole at the apron 1 (H) and apron 2 (I).

Step 2 : Place the top panel (A) upside down on a clear and smooth surface to avoid scratches. Assemble leg frame I (B) to the top panel (A) then attach apron (1) and apron (2). Insert nut (HW3) to the first hole of all apron and tighten with screw (HW2).

PREPARATION

- * Before beginning assembly of product, make sure all parts are present. Compare parts with part contents list and hardware contents list.
- * If any part is missing or damaged, do not attempt to assemble the product.
- * Estimated assembly time : 20 minutes
- * Tools required for assembly (included) : Allen key
- * Tools required for assembly (not included) : Philip screw driver
- * Tools required for assembly (not included) : Mallet
- * If you are having difficulty, our friendly Customer Care team is always here to help

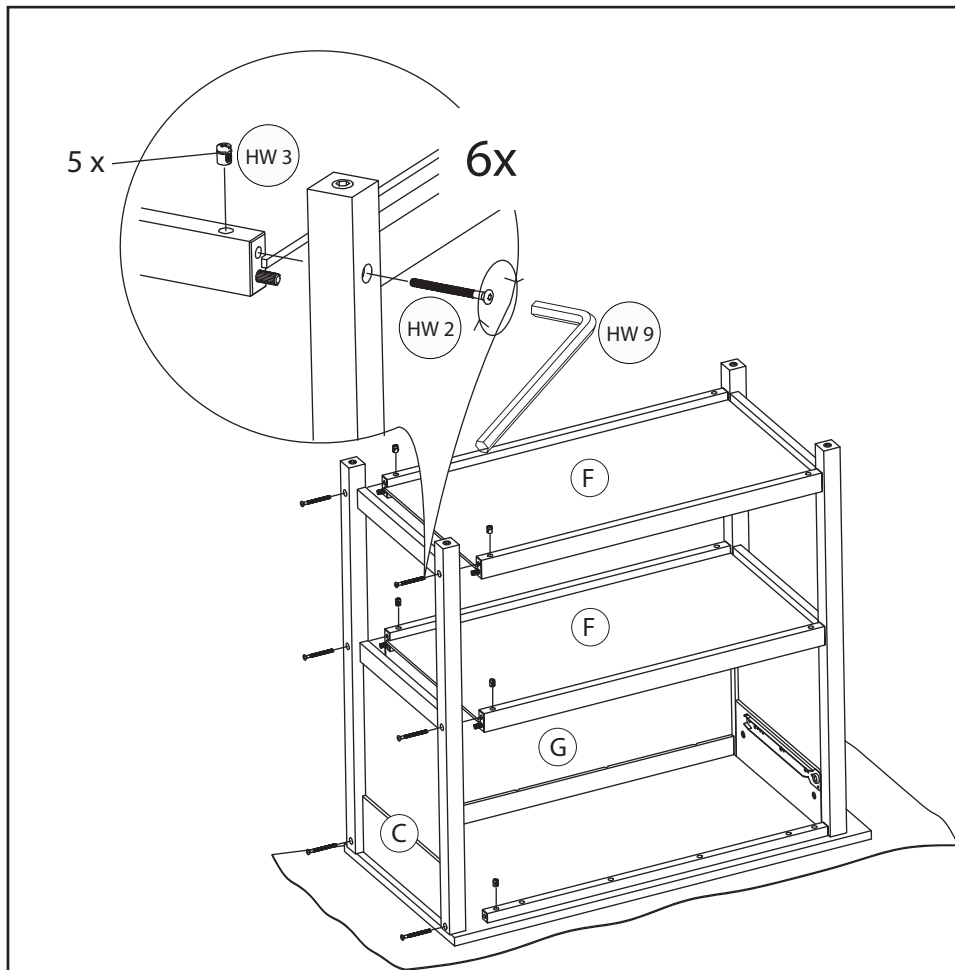

Step 3 : Insert shelf (F) into the groove of apron (H) and apron (I). Attach leg frame R to all of the aprons. Insert nut (HW3) at the first hole of the apron and tighten it with screws (HW2).

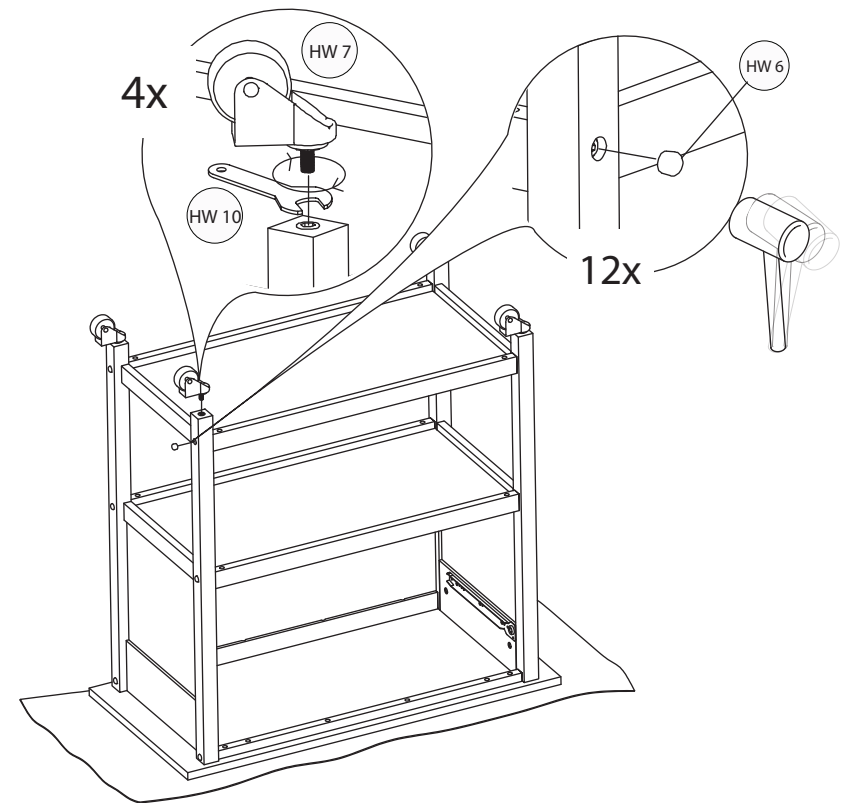

Step 4 : Attach the caster wheel (HW7) at the leg of frame (B) and frame (C). Tighten the wheel using the spanner (HW10). Insert wood button (HW6) cover hole at both frame (B) and frame (C).

PREPARATION

- * Before beginning assembly of product, make sure all parts are present. Compare parts with part contents list and hardware contents list.
- * If any part is missing or damaged, do not attempt to assemble the product.
- * Estimated assembly time : 20 minutes
- * Tools required for assembly (included) : Allen key
- * Tools required for assembly (not included) : Philip screw driver
- * Tools required for assembly (not included) : Mallet
- * If you are having difficulty, our friendly Customer Care team is always here to help.

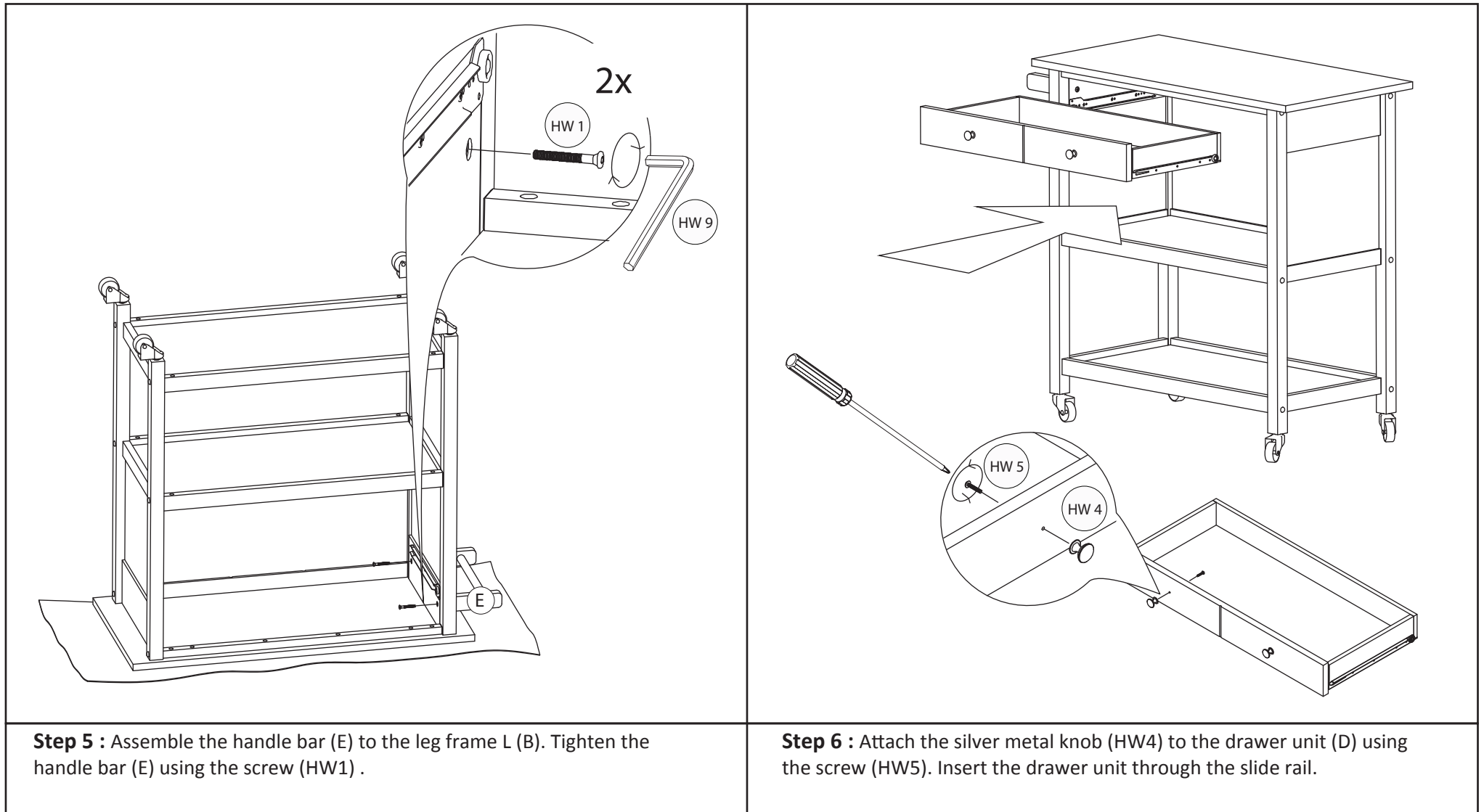

Step 5 : Assemble the handle bar (E) to the leg frame L (B). Tighten the handle bar (E) using the screw (HW1) .

Step 6 : Attach the silver metal knob (HW4) to the drawer unit (D) using the screw (HW5). Insert the drawer unit through the slide rail.