

INSTRUCTION MANUAL

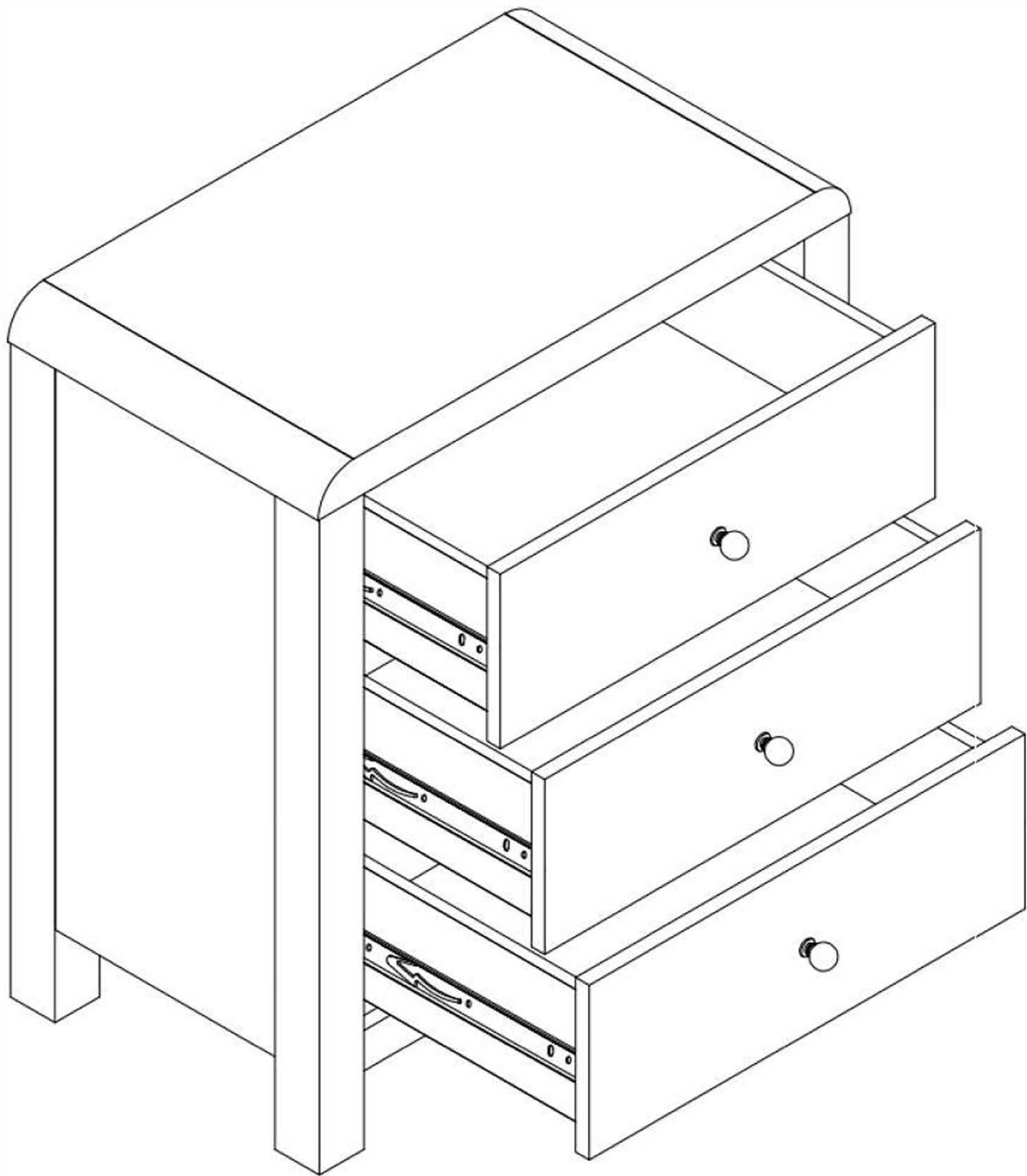

INSTRUCTION MANUAL

Contact Information

Question about your product? We're here to help. Contact us by:



Orders FAQ



Product Assembly



Product Inquiry



Chat Support



Returns & Refunds

If you have any problems, please send your order number and photos to us. We will contact you within 24 hours and provide you with a satisfactory solution.

! NOTICE Please retain these instructions for future reference.

- Carefully unpack all the components and verify that all the necessary parts are included as listed in the packaging.
- Identify each component and refer to the provided assembly diagram or step-by-step instructions.
- Assemble the furniture in the order specified to ensure proper alignment and fit.
- Use the provided tools or recommended tools for assembly. Do not use excessive force when tightening screws or bolts.
- If any difficulties arise during assembly. Consult the troubleshooting section or contact our customer support.

 **ASSEMBLY INSTRUCTIONS**

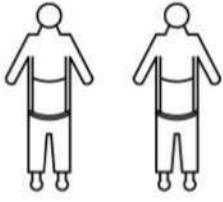



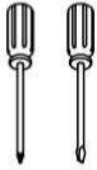



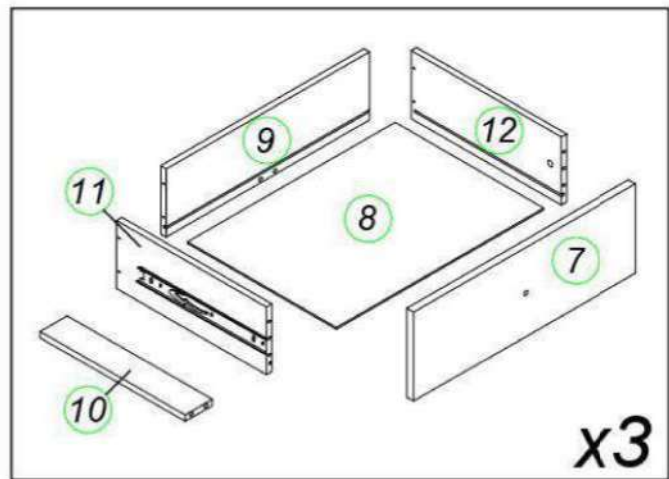
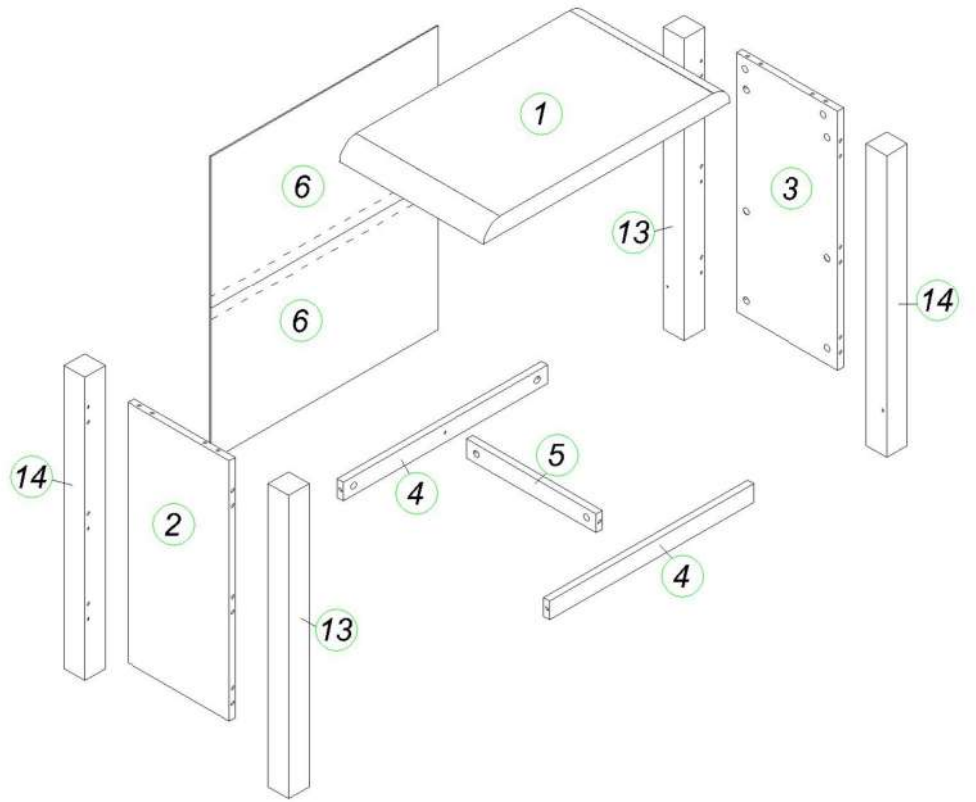

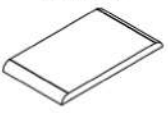

2 people



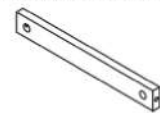

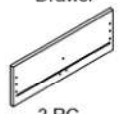
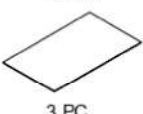

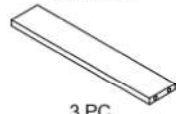
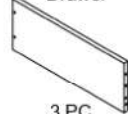
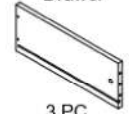











Phillips Screwdriver

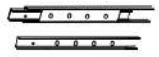

☰ PARTS LIST

- | | | | | | |
|---|--|--|---|---|---|
| 01
Top Panel

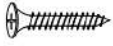
1 PC | 02
Left Side Panel

1 PC | 03
Right Side Panel

1 PC | 04
Bottom Support Front

2 PC | 05
Bottom Support Center

1 PC | 06
Back cover

1 PC |
| 07
Front Panel of Drawer

3 PC | 08
Bottom Board of Drawer

3 PC | 09
Back Panel of Drawer

3 PC | 10
Bottom Bracket Panel of Drawer

3 PC | 11
Left Panel of Drawer

3 PC | 12
Right Panel of Drawer

3 PC |
| 13
Left Leg

2 PC | 14
Right Leg

2 PC | | | | |

☰ HARDWARE LIST

A Minifix (16MM)  22 PCS	B Minicam (16MM)  22 PCS	C Allen Key  1 PCS	D Ø8x30mm Dowel  16 PCS	E Ø6x30mm Dowel  24 PCS	F Ø4x25mm Handle Screw  3 PCS
G Wooden Knob  3 PCS	H Ø4x32mm Screw  12 PCS	I Nail  12 PCS	J Minifix (12MM)  6 PCS	K Minicam (12MM)  6 PCS	L Plastic Stopper 35MM  12 PCS
M Ø3.5x16mm Screw  24 PCS	N Full Extension- (250mm)  3 SET	O Ø3x12mm Screw  18 PCS	P Ø3.5x25mm Screw  12 PCS	Q E.V.A Rubber Foam 15 X 25 X 2mm  4 PCS	



If you are missing any parts, please provide your order number and circle the part number. Send us a photo of this, and we will provide you with a satisfactory solution. Thank you.

STEP 1

HOW TO REMOVE THE DRAWER / COMMENT RETIRER LE TIROIR / CÓMO QUITAR EL CAJÓN

- Open drawer (top) and push the clips of full extension on the left / right and then take out the drawer.
- Ouvrez le tiroir (en haut) et poussez les clips d'extension complète à gauche et à droite, puis sortez le tiroir.
- Abra el cajón (arriba) y empuje los clips de extensión completa a la izquierda y a la derecha y luego saque el cajón.

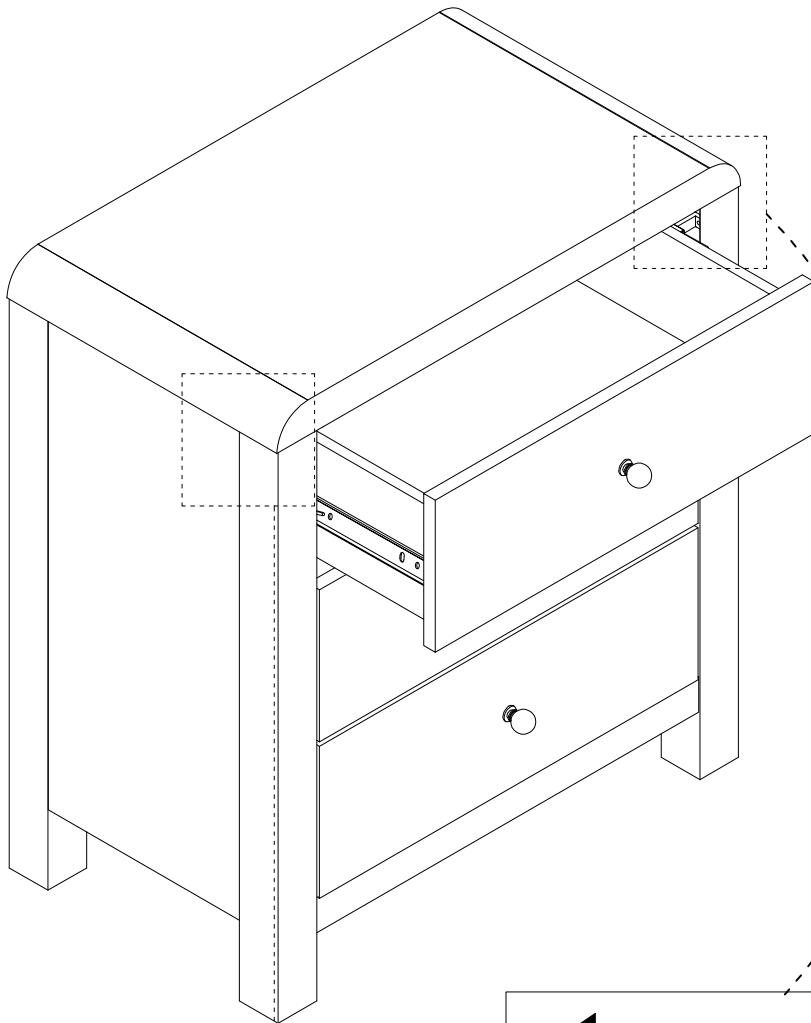

- The slide assembly is complete, pulling a certain resistance, is the characteristics of the slide itself, more use for a period of time after the effect will be better!
- L'assemblage de la glissière est complet, tirant une certaine résistance, est les caractéristiques de la glissière elle-même, plus d'utilisation pour une période de temps après l'effet sera meilleur !
- ¡El conjunto de diapositivas es completa, tirando de una cierta resistencia, es las características de la propia diapositiva, más uso durante un período de tiempo después de que el efecto será mejor!

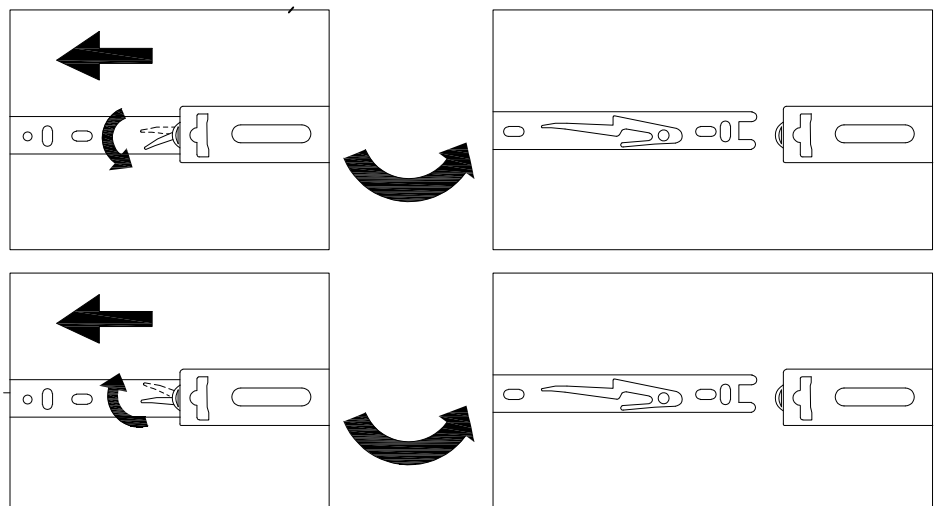

STEP 2

HOW TO REMOVE THE DRAWER / COMMENT RETIRER LE TIROIR / CÓMO QUITAR EL CAJÓN

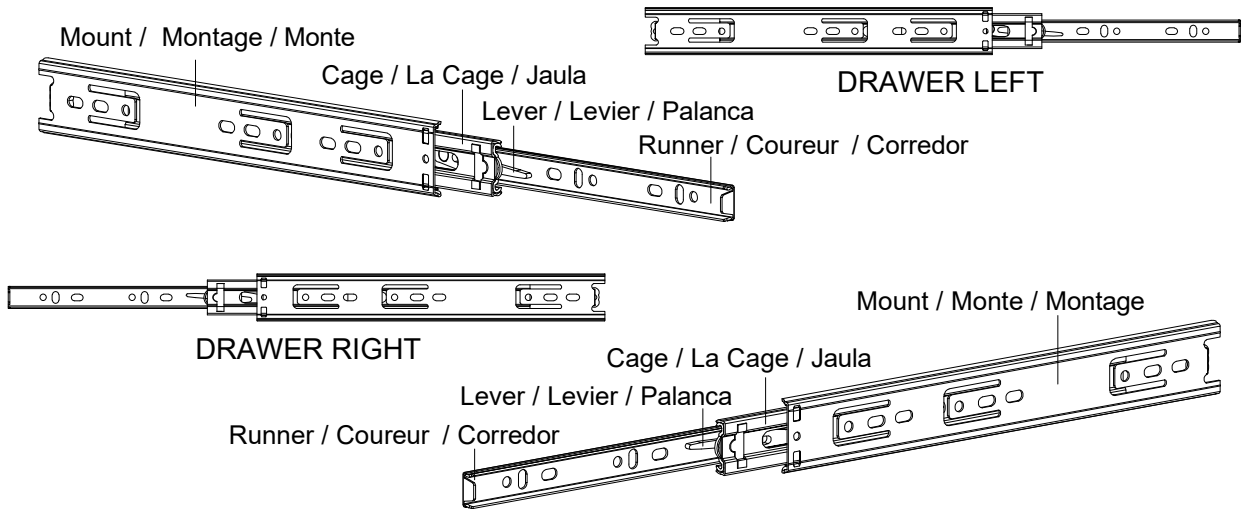

STEP 1 - Extend slide (L)
Extension de la glissière (L)
Extender corredera (L)

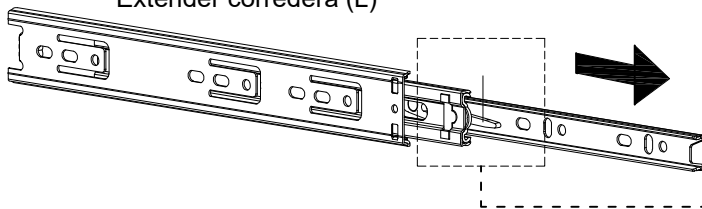

STEP 2 - Push lever (L)
Levier de poussée (L)
Palanca de empuje (L)

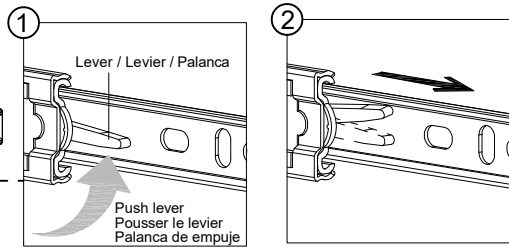

STEP 2 - Push lever (R)
Pousser le levier (R)
Palanca de empuje (R)

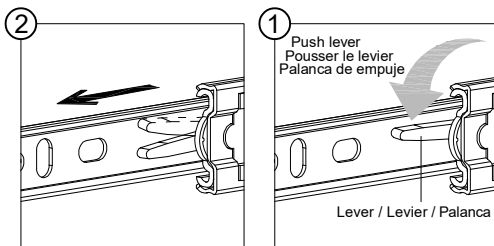

STEP 1 - Extend slide (R)
Extension de la glissière (R)
Extender corredera (R)

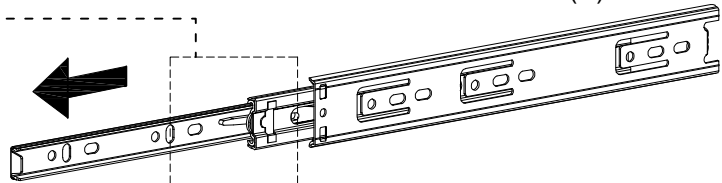

STEP 3 - Remove runner / Retirer le patin / Quitar corredor

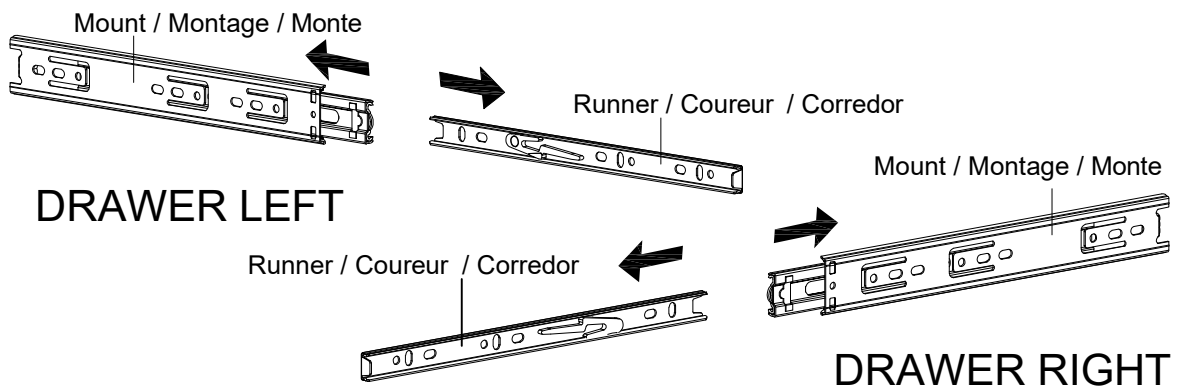

STEP 1

Please tighten the screws after completing all installation.

Por favor, apriete los tornillos después de instalar todo.

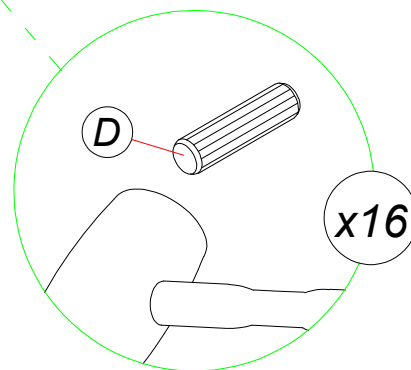
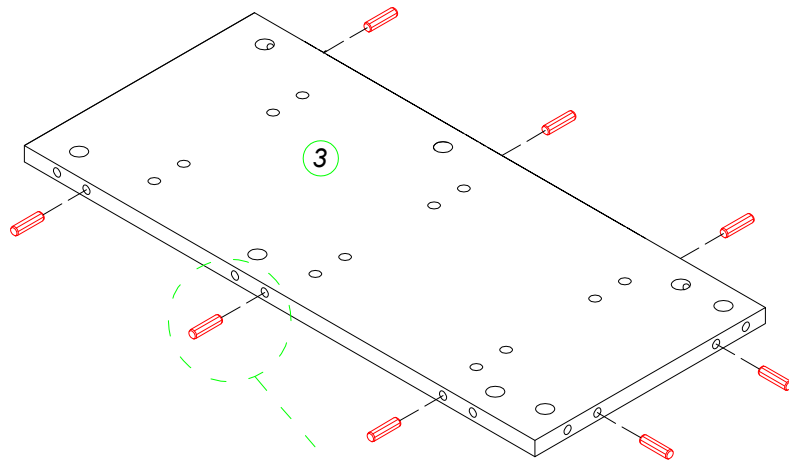
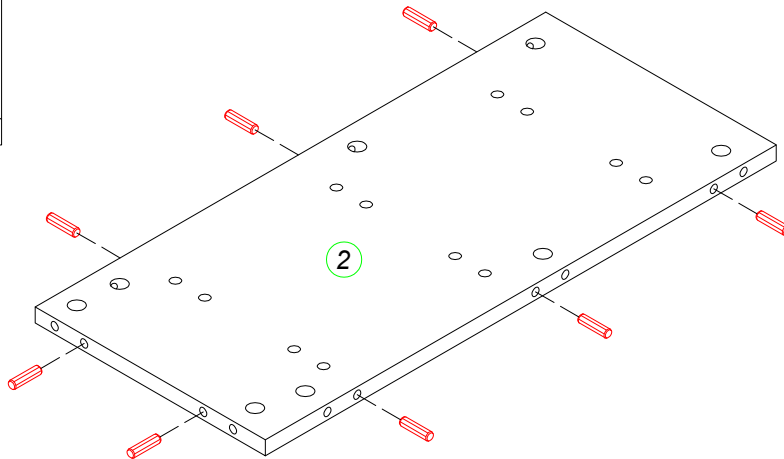
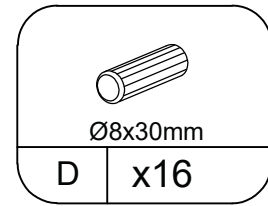
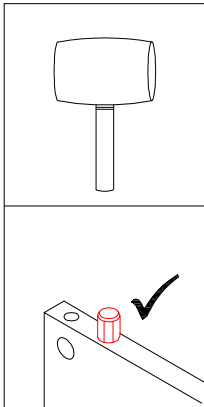

STEP 2

Please tighten the screws after completing all installation.

Por favor, apriete los tornillos después de instalar todo.

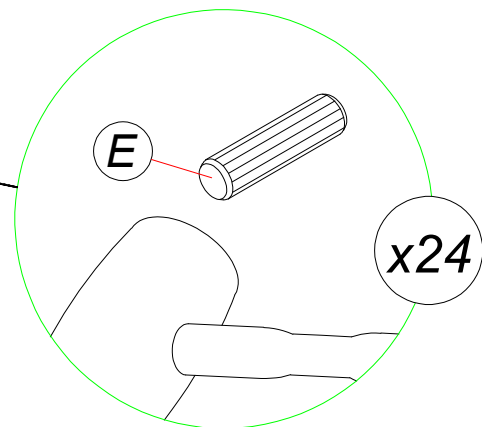
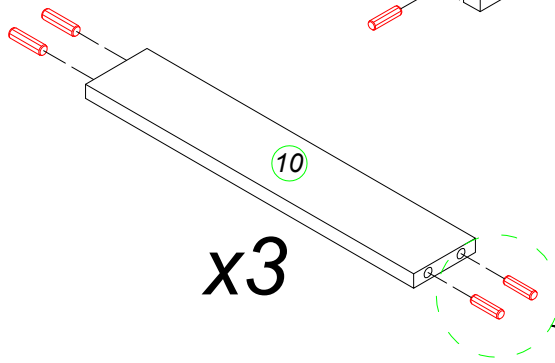
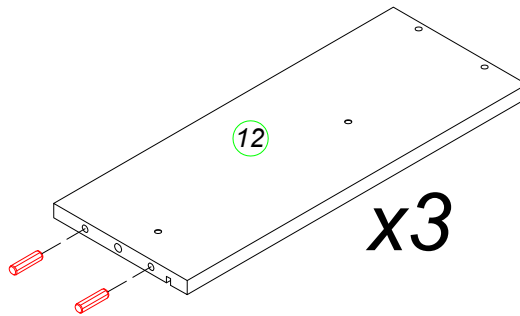
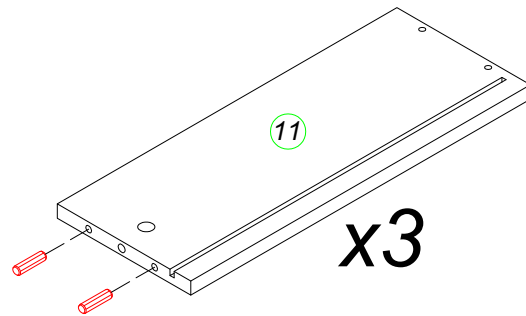
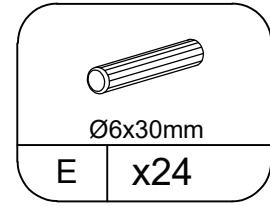
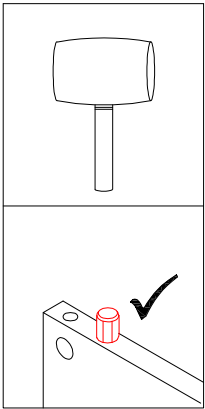

STEP 3

Please tighten the screws after completing all installation.

Por favor, apriete los tornillos después de instalar todo.

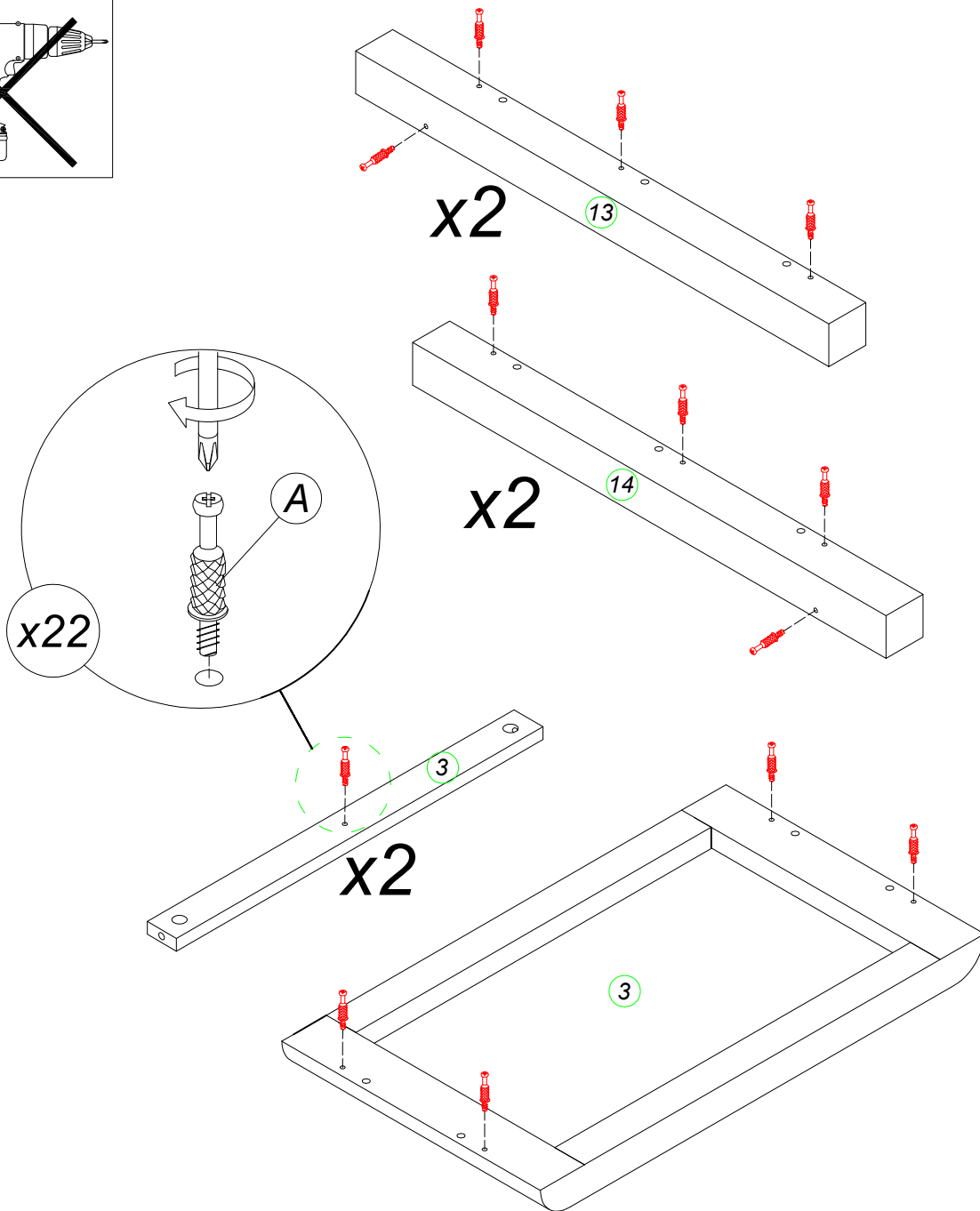
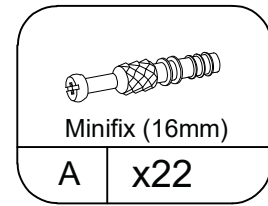
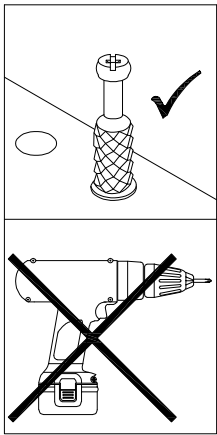

STEP 4

Please tighten the screws after completing all installation.

Por favor, apriete los tornillos después de instalar todo.

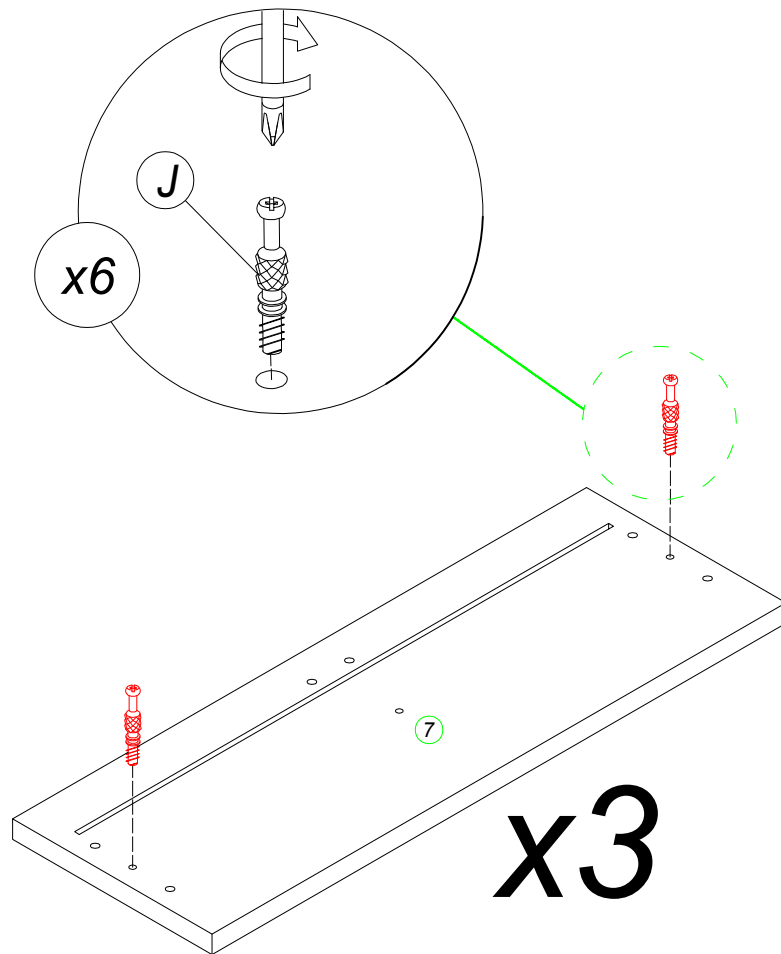
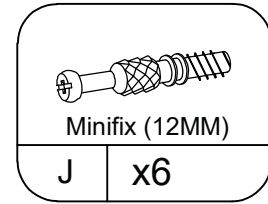
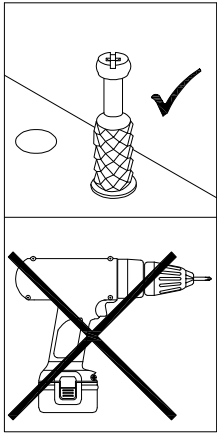

x3

STEP 5

Please tighten the screws after completing all installation.

Por favor, apriete los tornillos después de instalar todo.

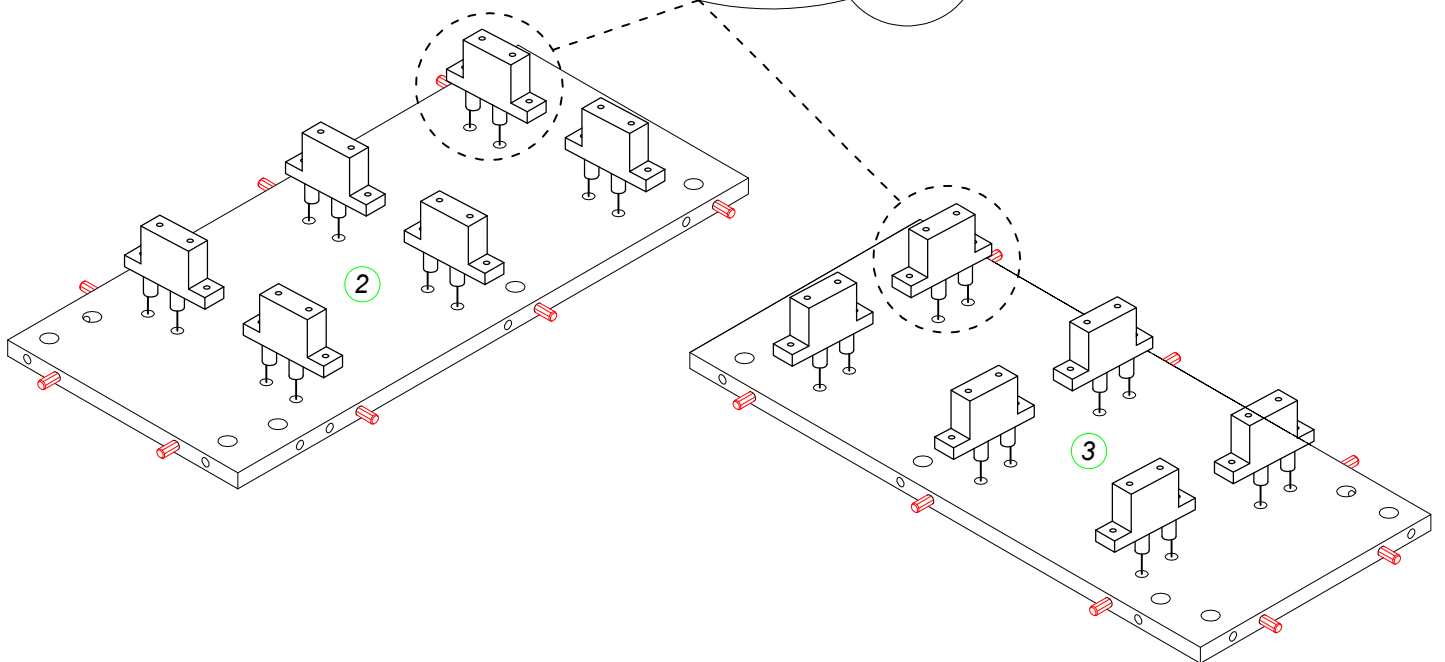
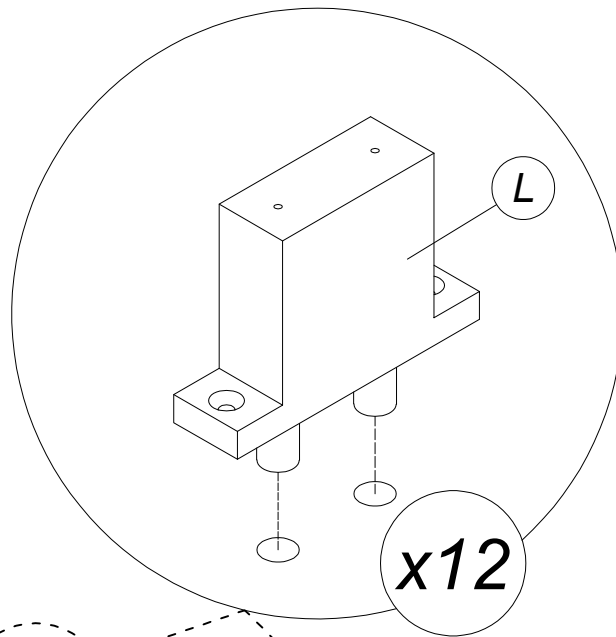
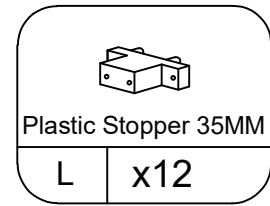

STEP 6

Please tighten the screws after completing all installation.

Por favor, apriete los tornillos después de instalar todo.

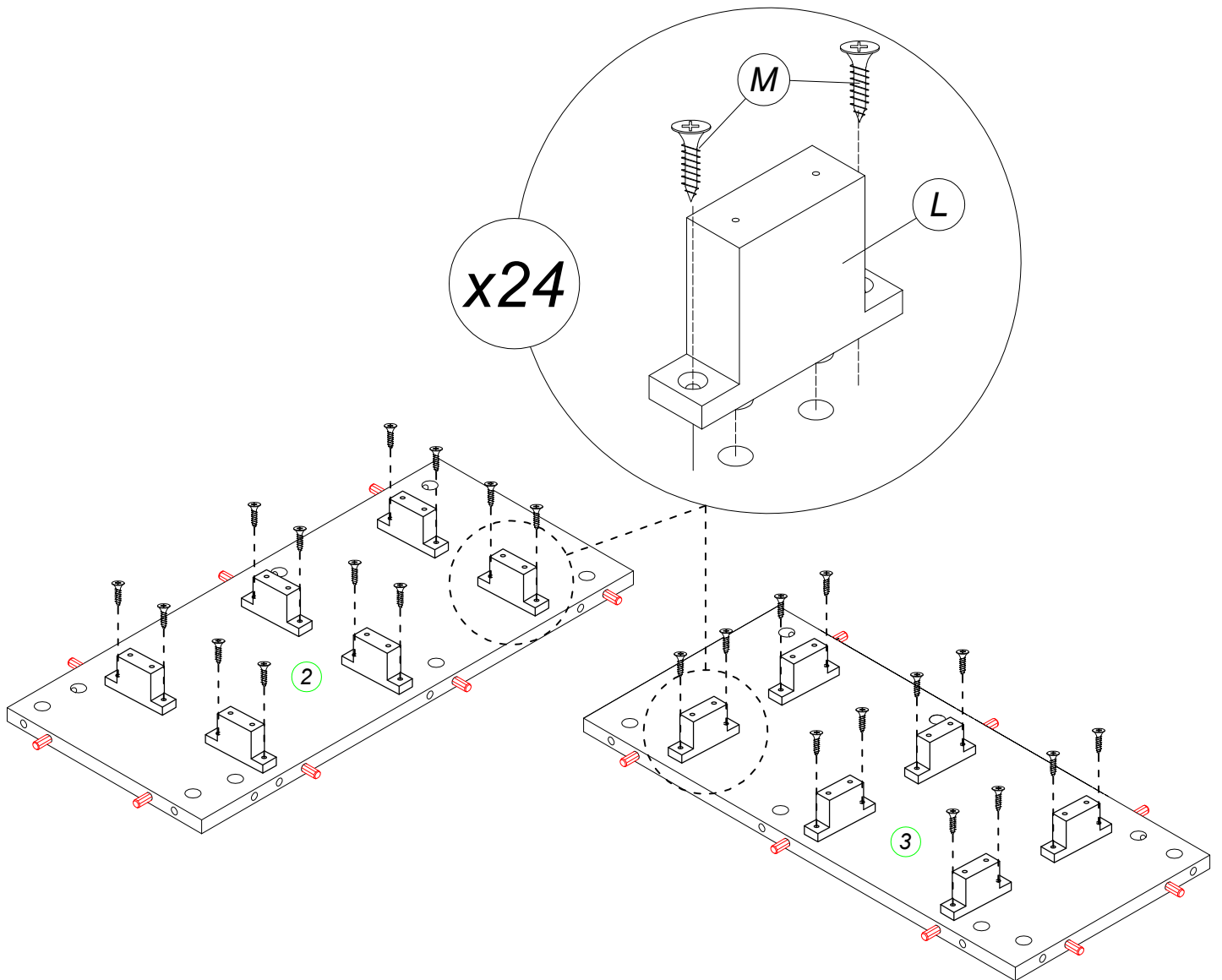
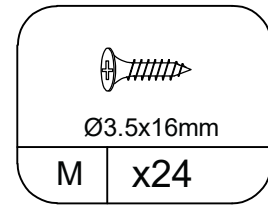

STEP 7

Please tighten the screws after completing all installation.

Por favor, apriete los tornillos después de instalar todo.

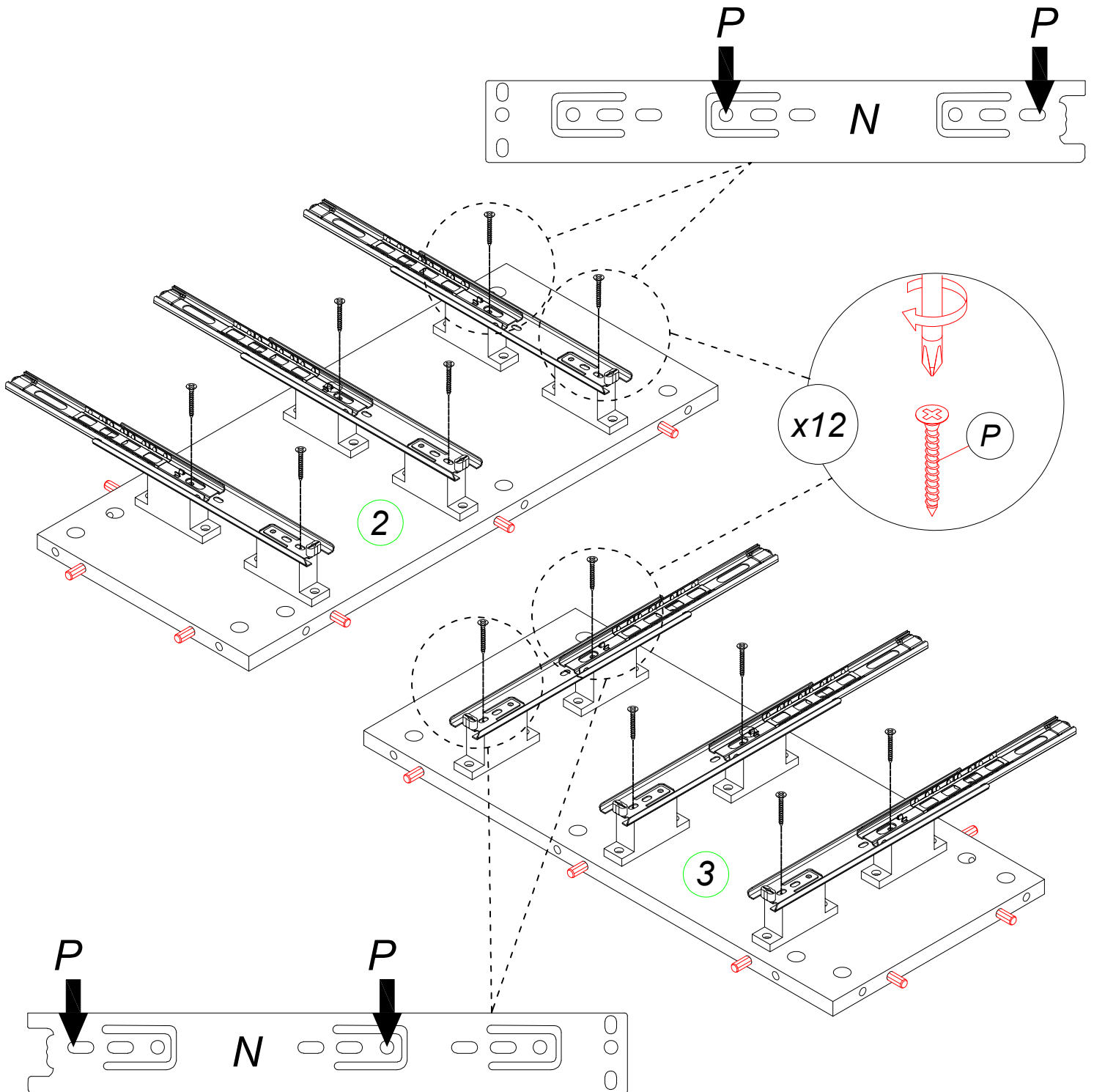
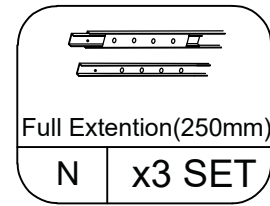
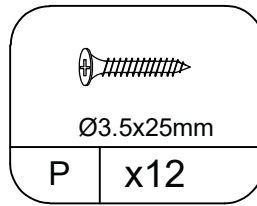

STEP 8

Please tighten the screws after completing all installation.

Por favor, apriete los tornillos después de instalar todo.

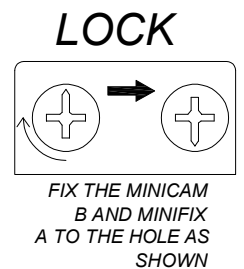
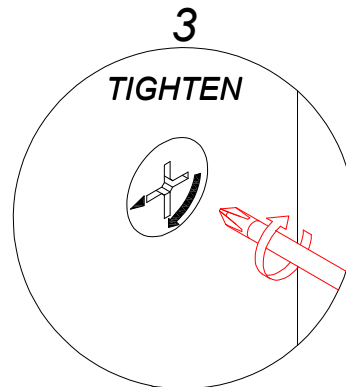
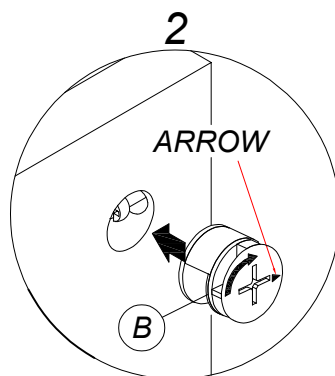
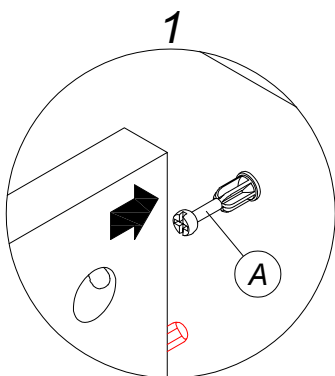
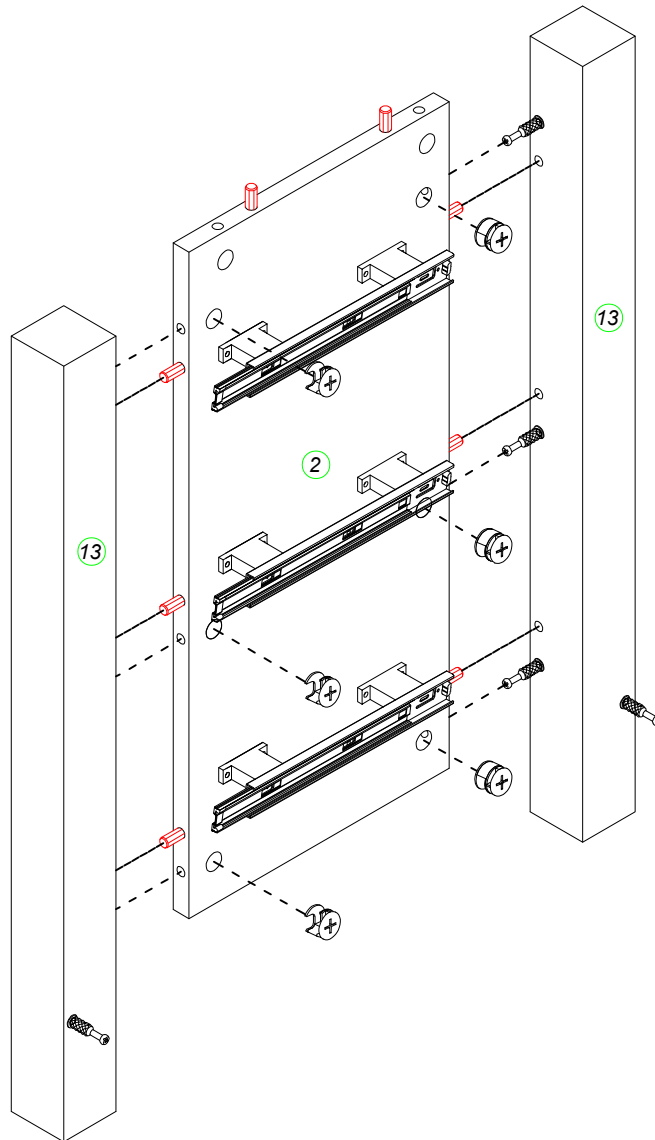
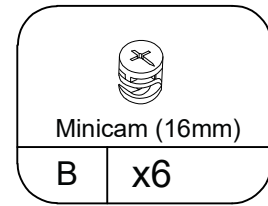

STEP 9

Please tighten the screws after completing all installation.

Por favor, apriete los tornillos después de instalar todo.

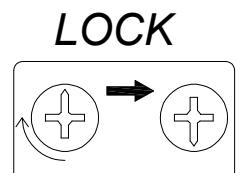
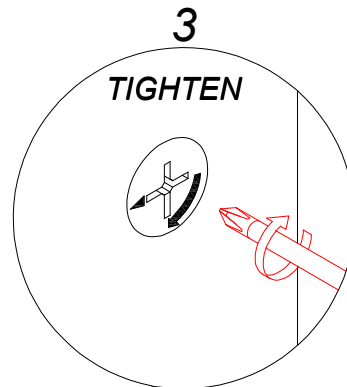
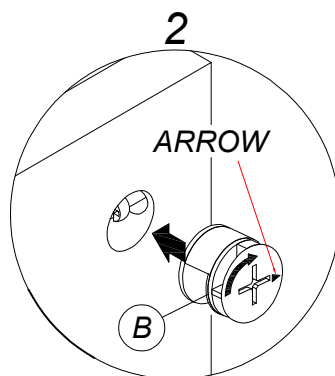
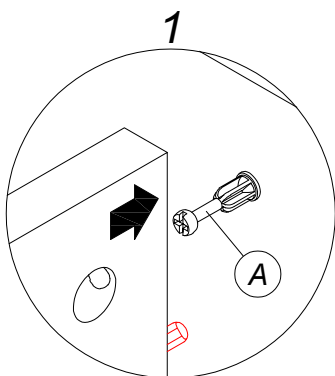
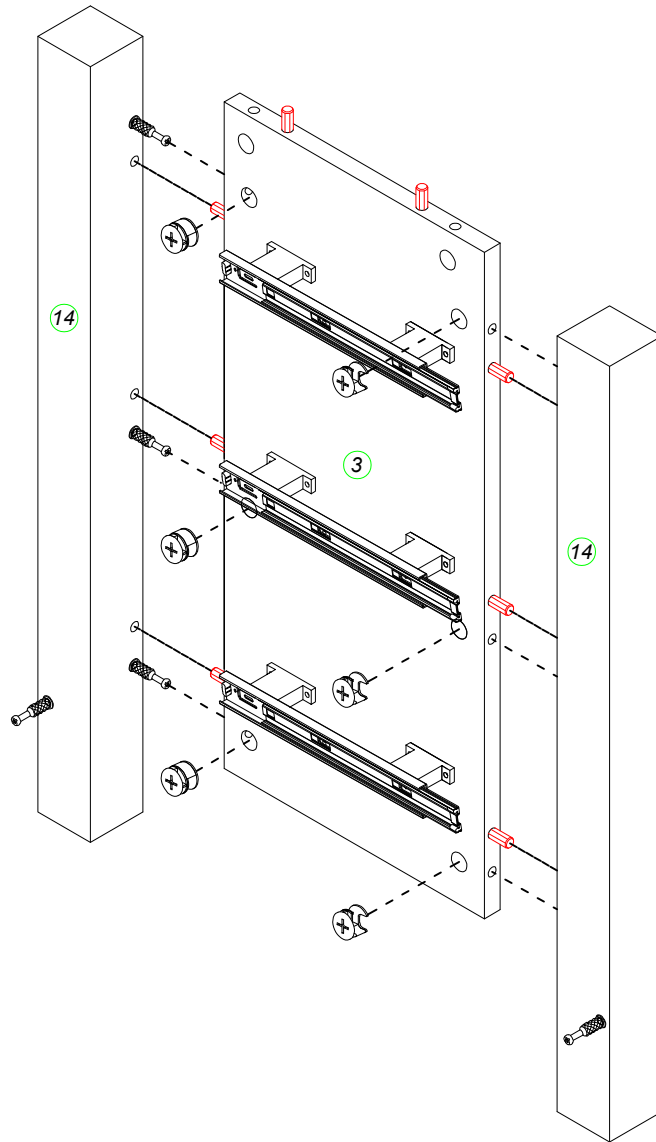
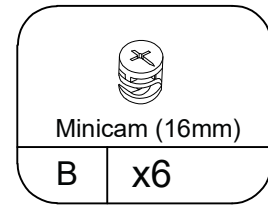

FIX THE MINICAM B AND MINIFIX A TO THE HOLE AS SHOWN

STEP 10

Please tighten the screws after completing all installation.

Por favor, apriete los tornillos después de instalar todo.

	
Minicam (16mm)	
B	x2

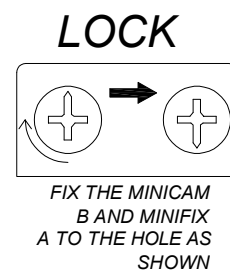
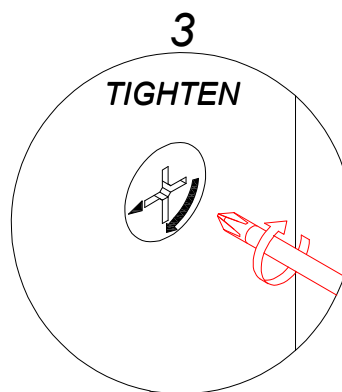
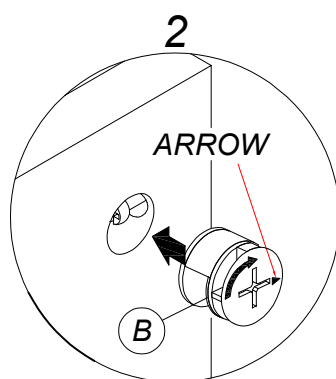
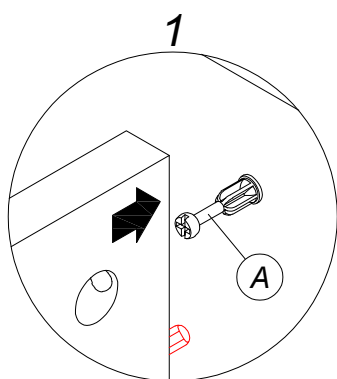
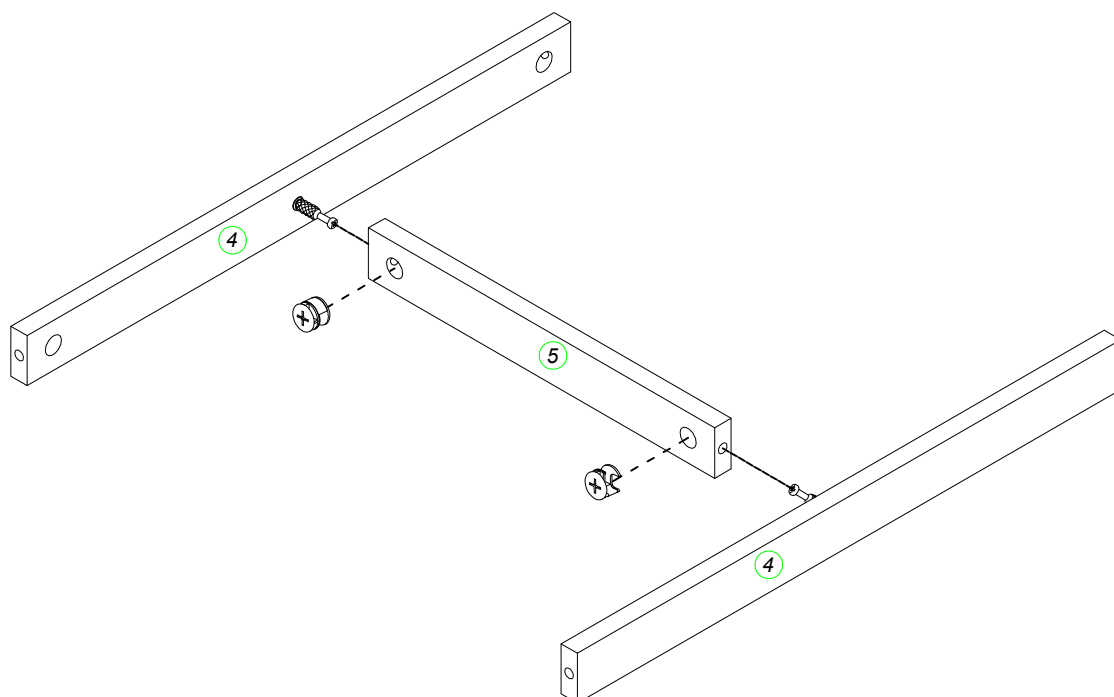

STEP 11

Please tighten the screws after completing all installation.

Por favor, apriete los tornillos después de instalar todo.

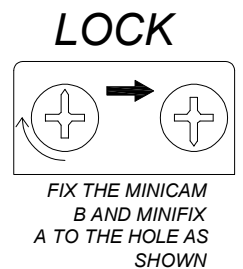
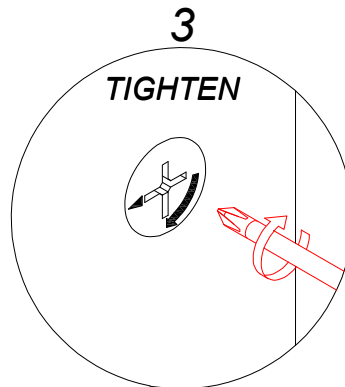
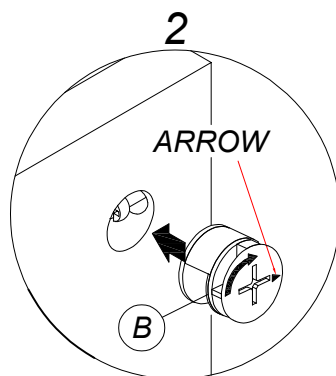
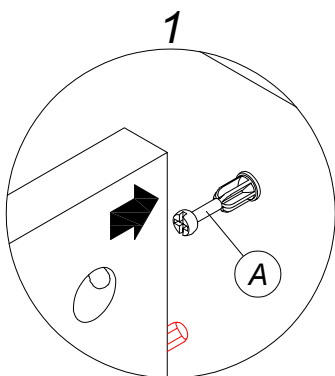
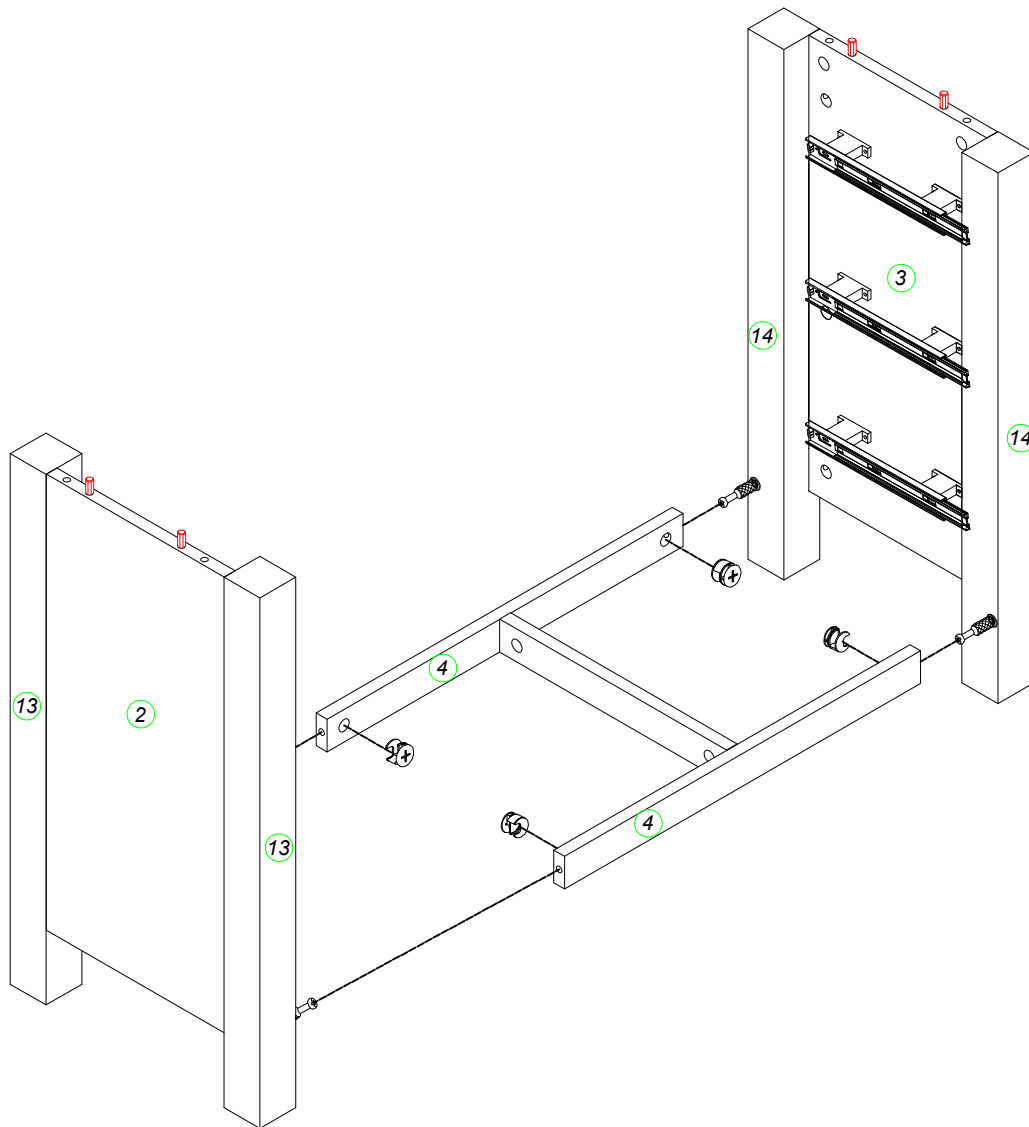
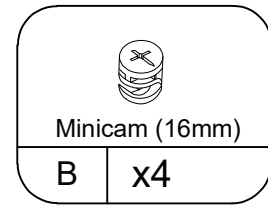

STEP 12 Please tighten the screws after completing all installation.

Por favor, apriete los tornillos después de instalar todo.

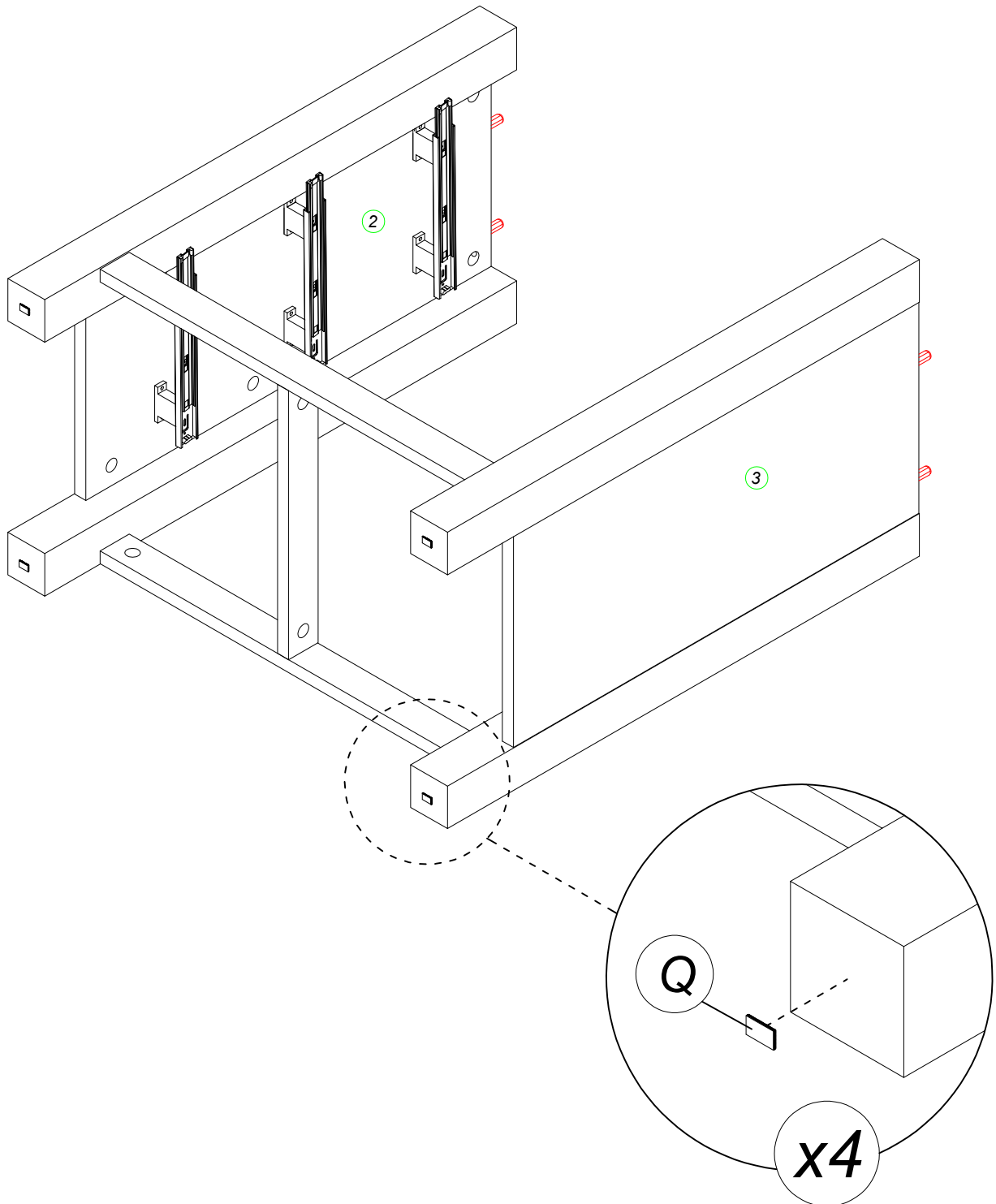
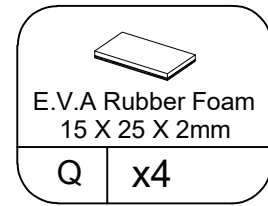

STEP 13

Please tighten the screws after completing all installation.

Por favor, apriete los tornillos después de instalar todo.

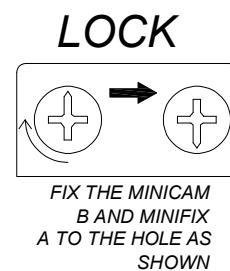
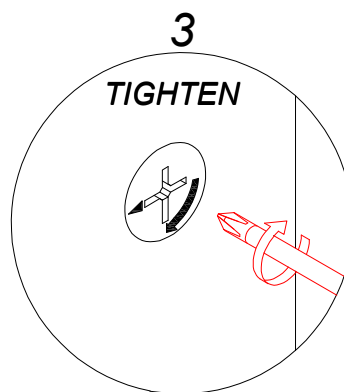
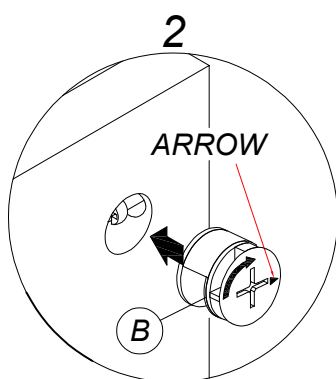
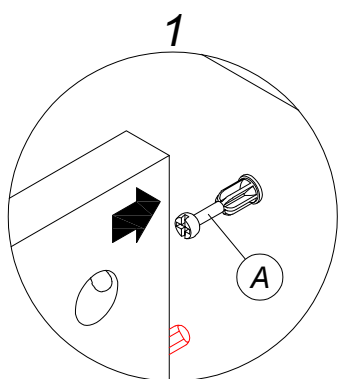
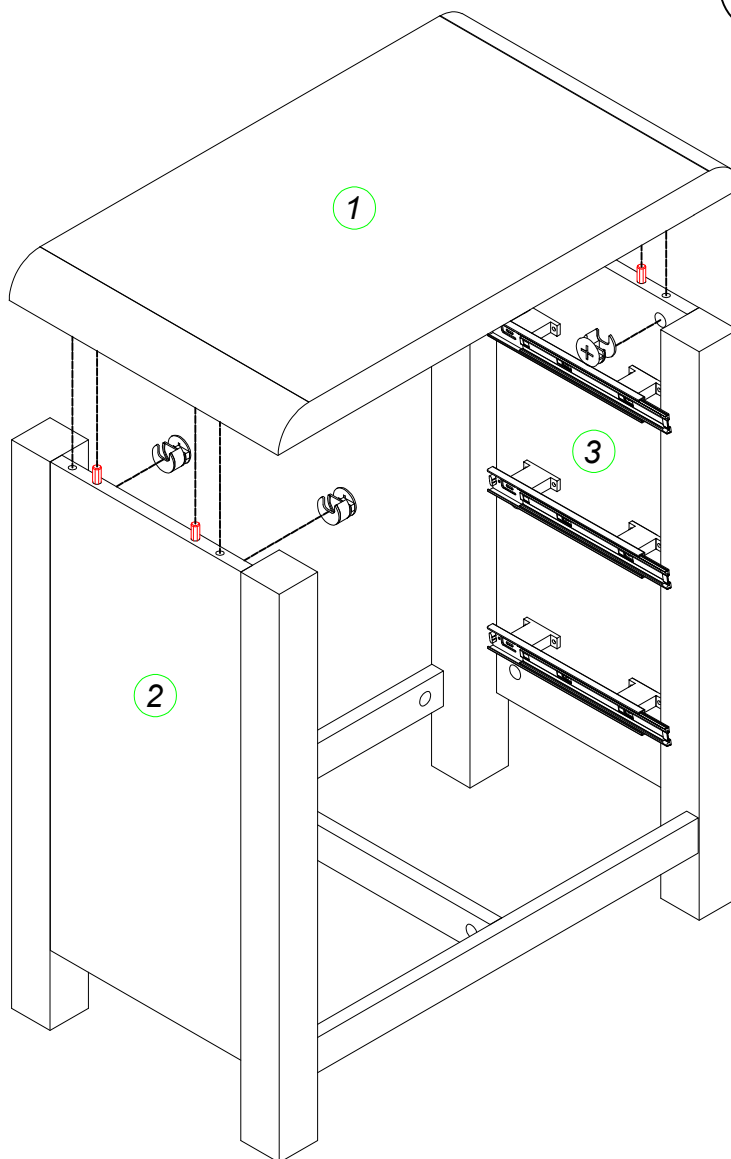
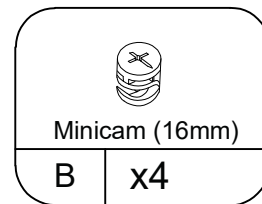

STEP 14 Please tighten the screws after completing all installation.

Por favor, apriete los tornillos después de instalar todo.

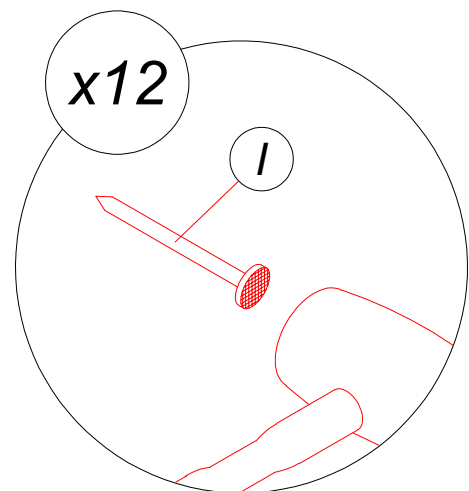
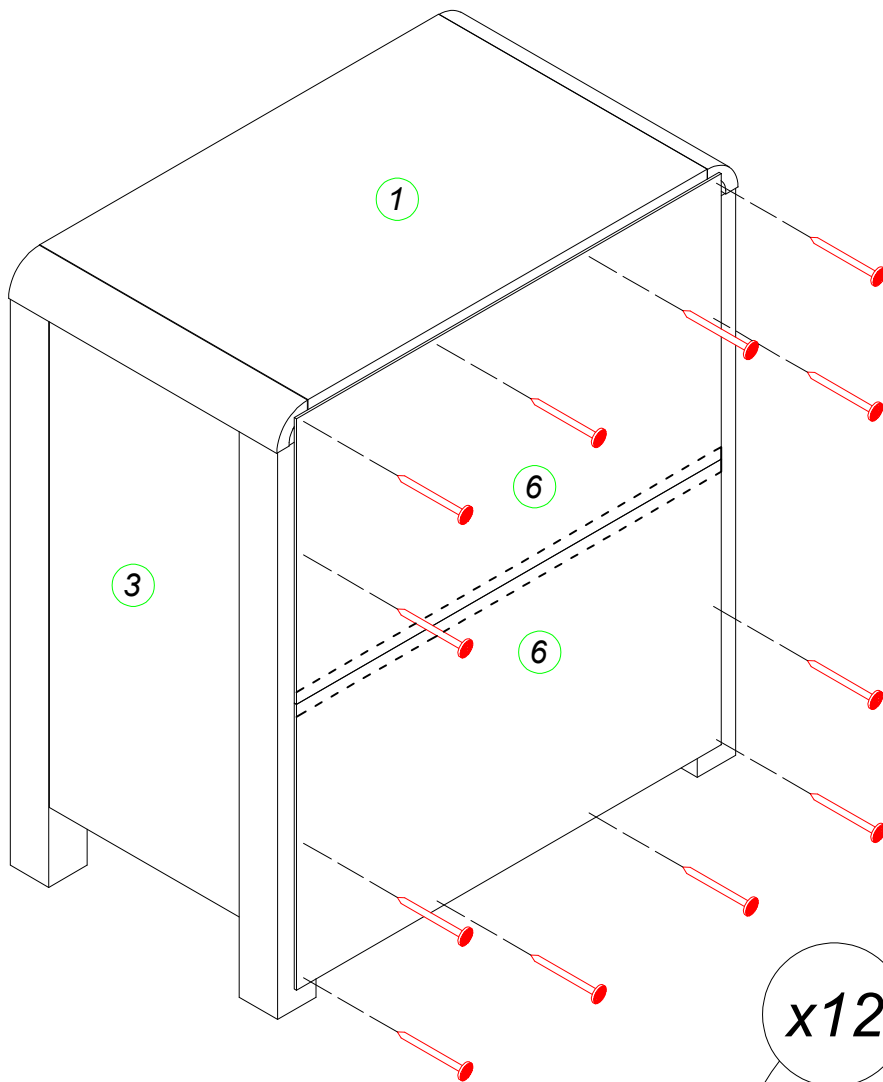
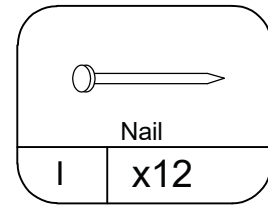

STEP 15 Please tighten the screws after completing all installation.

Por favor, apriete los tornillos después de instalar todo.

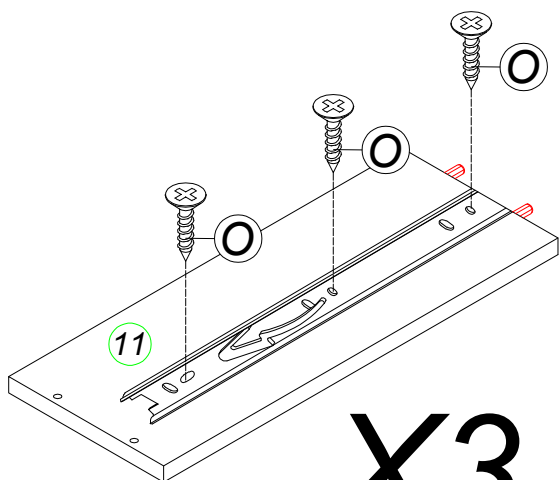
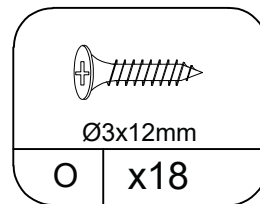
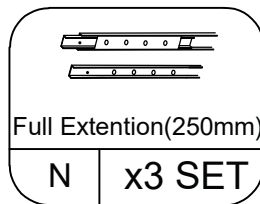

X3

DRAWER SIDE LEFT

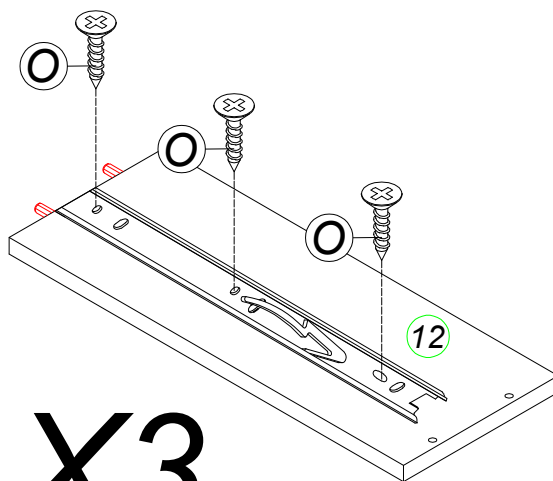

X3

DRAWER SIDE RIGHT

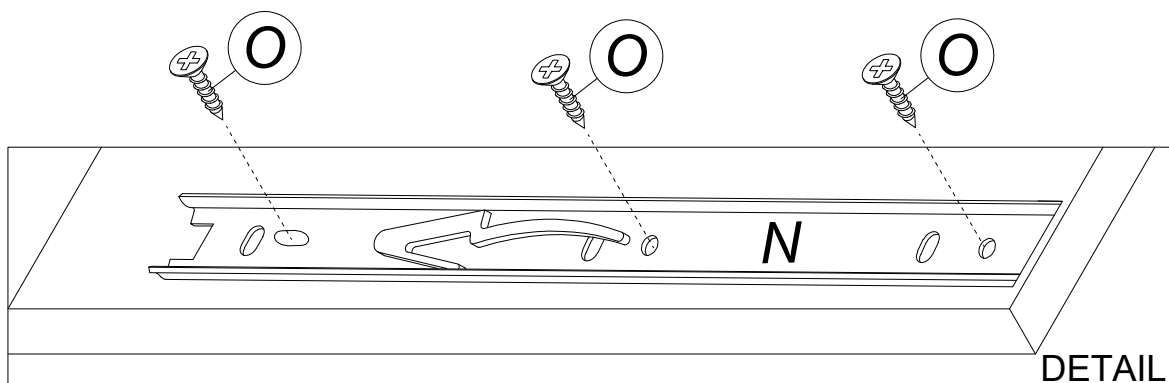

STEP 16 Please tighten the screws after completing all installation.

Por favor, apriete los tornillos después de instalar todo.

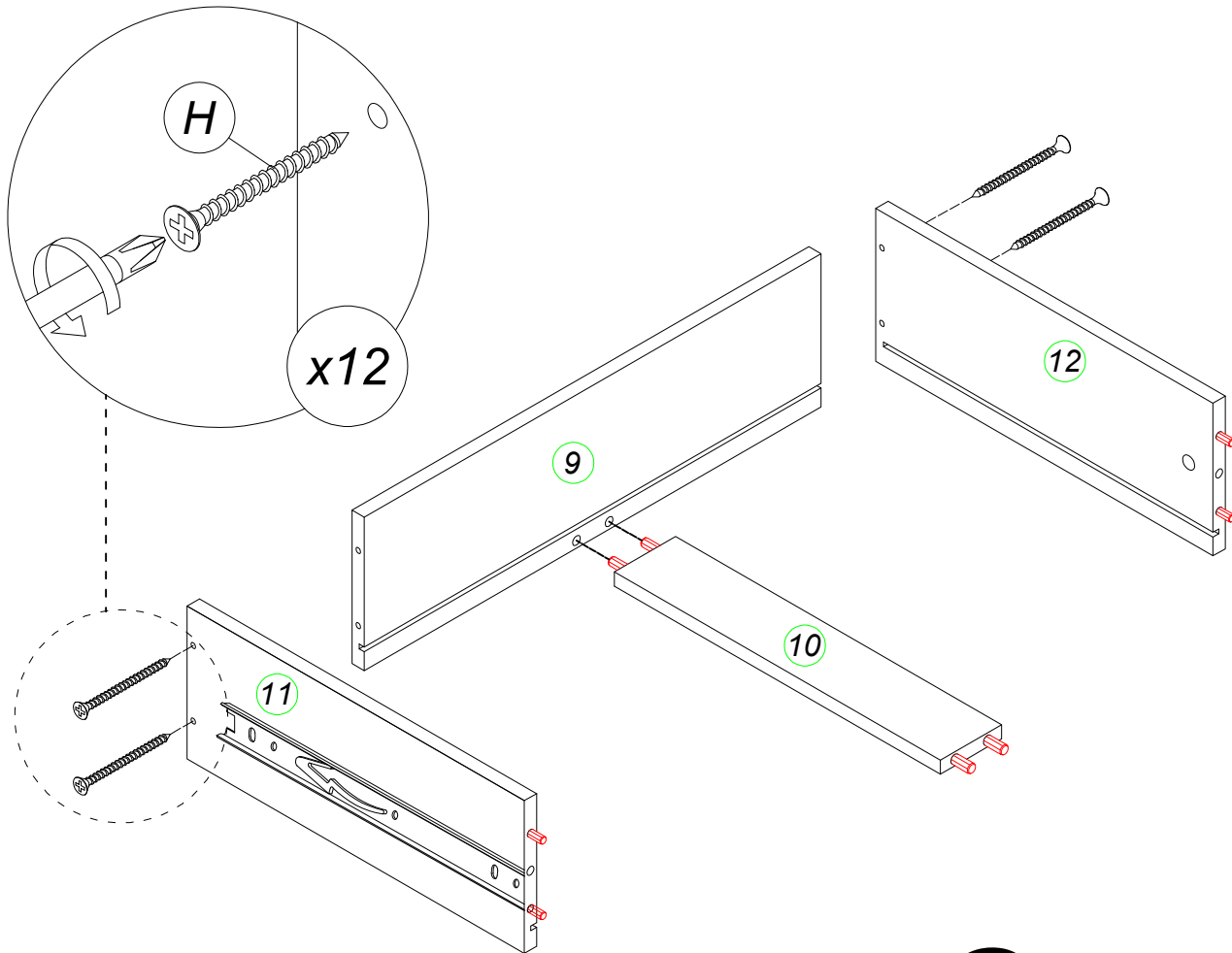
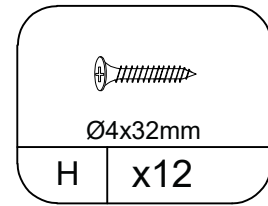

x3

STEP 17 Please tighten the screws after completing all installation.

Por favor, apriete los tornillos después de instalar todo.

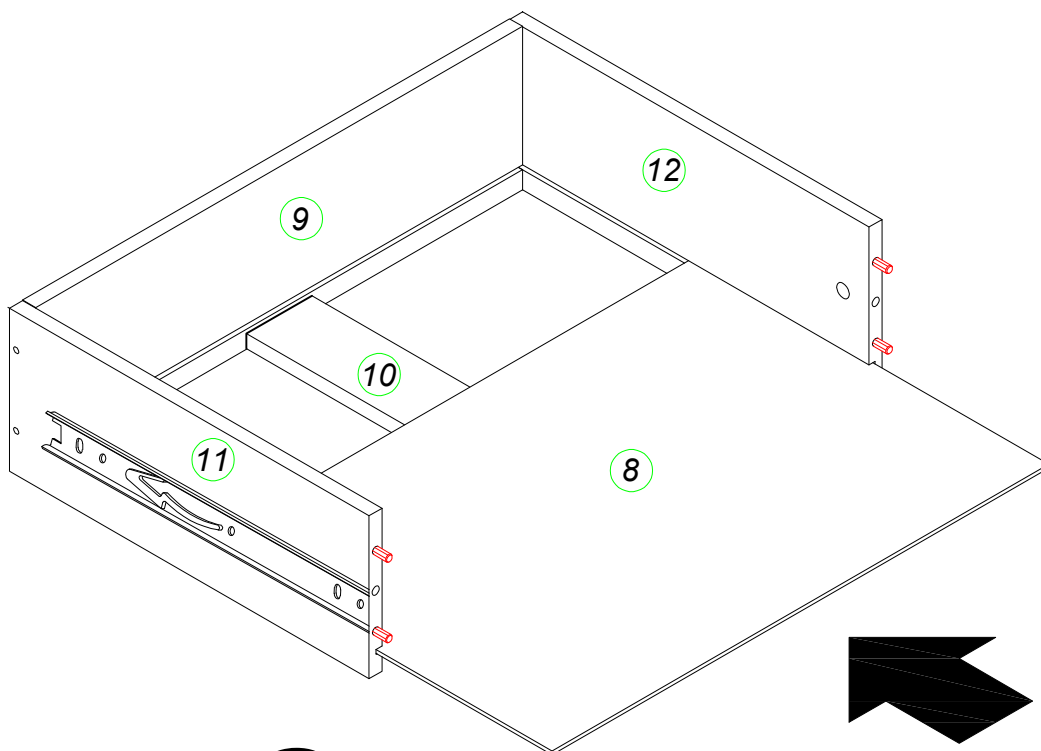

x3

STEP 18 Please tighten the screws after completing all installation.

Por favor, apriete los tornillos después de instalar todo.

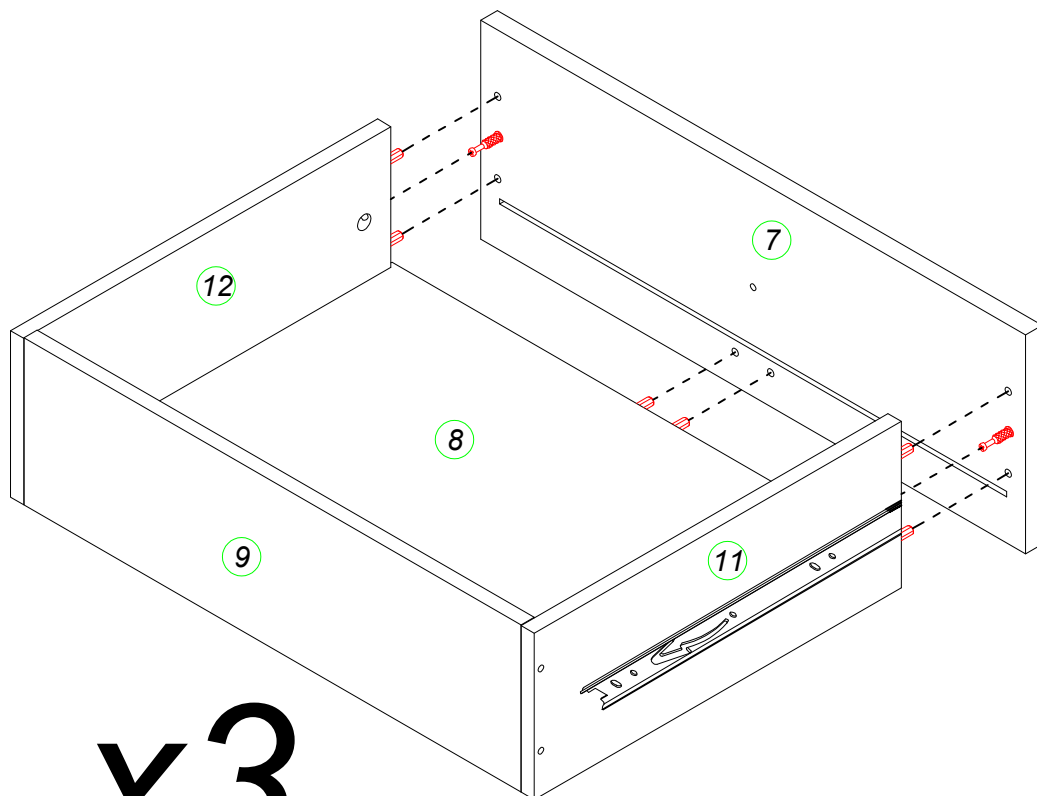
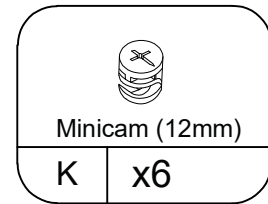

x3

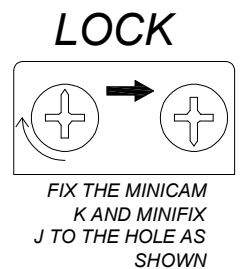
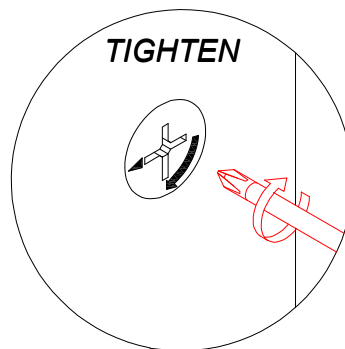
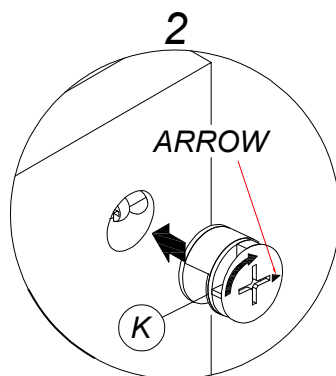
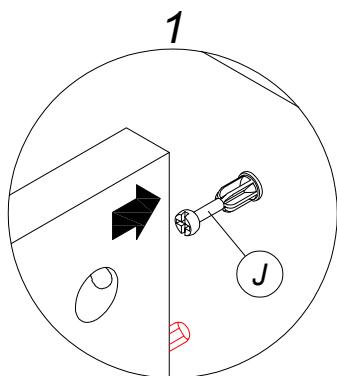

STEP 19 Please tighten the screws after completing all installation.

Por favor, apriete los tornillos después de instalar todo.

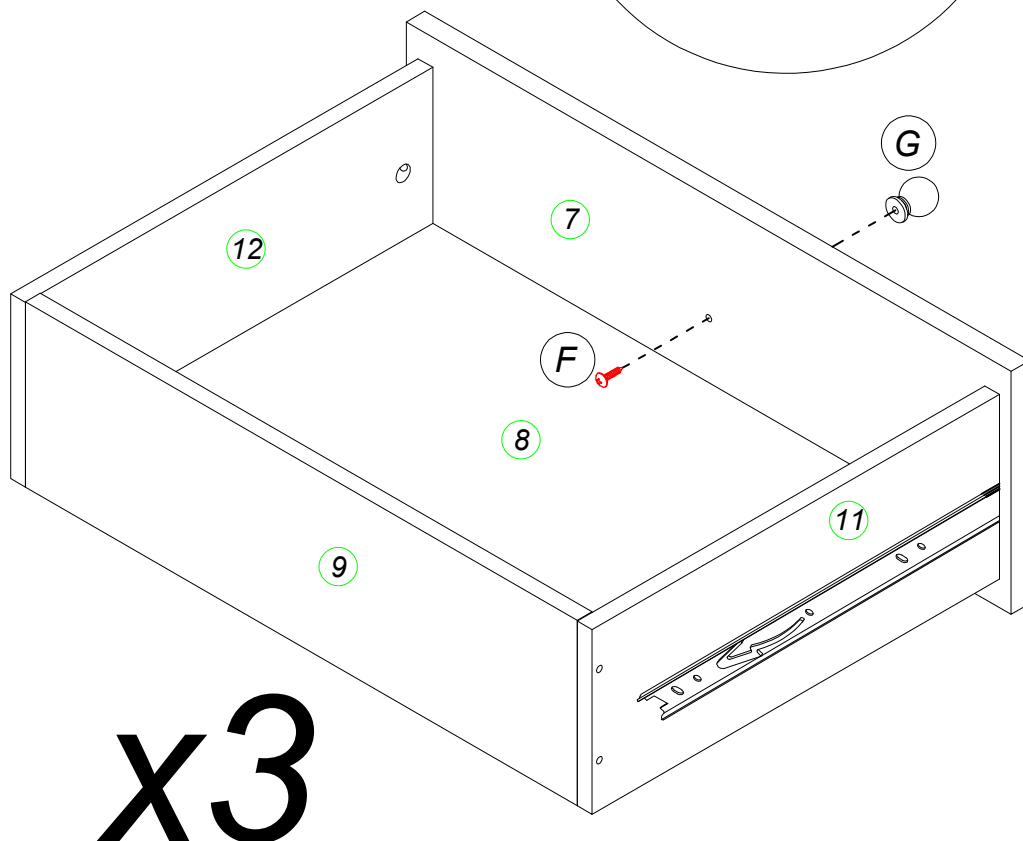
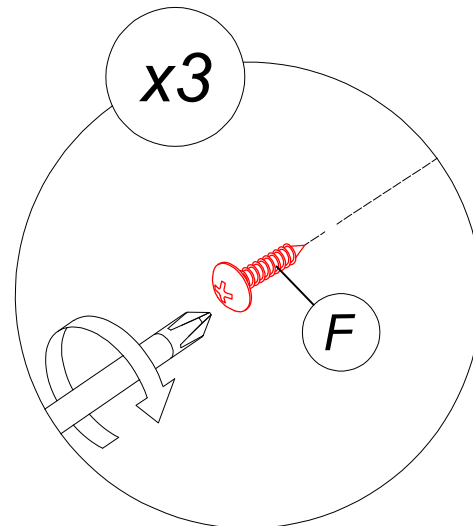
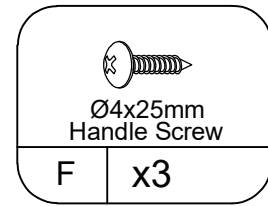
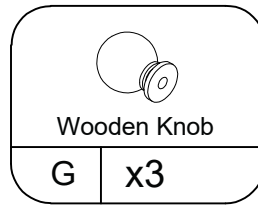

STEP 20 Please tighten the screws after completing all installation.

Por favor, apriete los tornillos después de instalar todo.

Start by assembling the bottom most drawer first and work upwards /
Commencez par assembler le tiroir le plus bas et progressez vers le haut /
Comience ensamblando primero el cajón más inferior y trabaje hacia arriba.

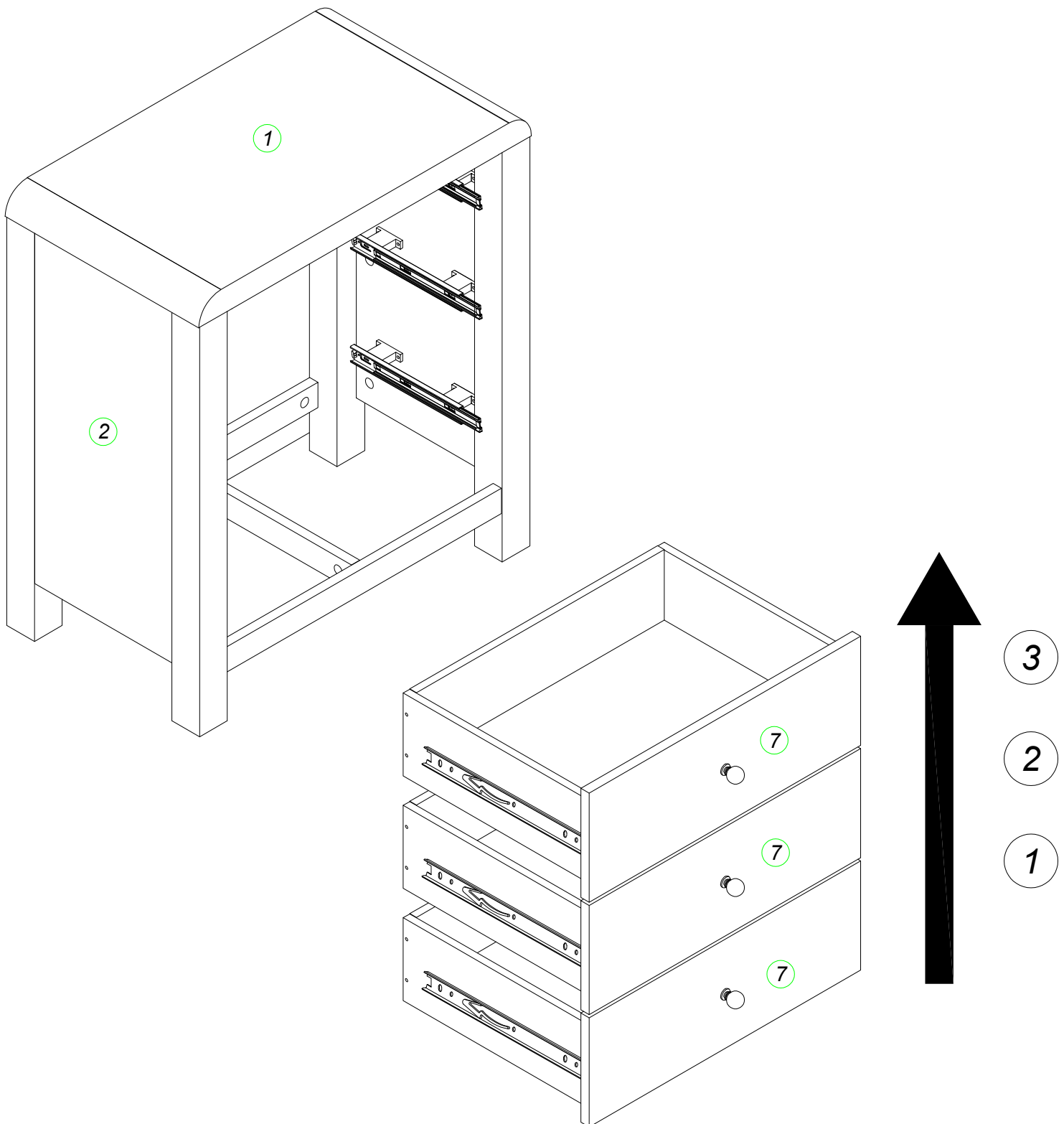

STEP 21 Please tighten the screws after completing all installation.

Por favor, apriete los tornillos después de instalar todo.

Assemble one by one drawer from bottom to top /
Assemblez un par un tiroir du bas à Retour au début /
Ensamblar uno por uno cajón de abajo hacia arriba.

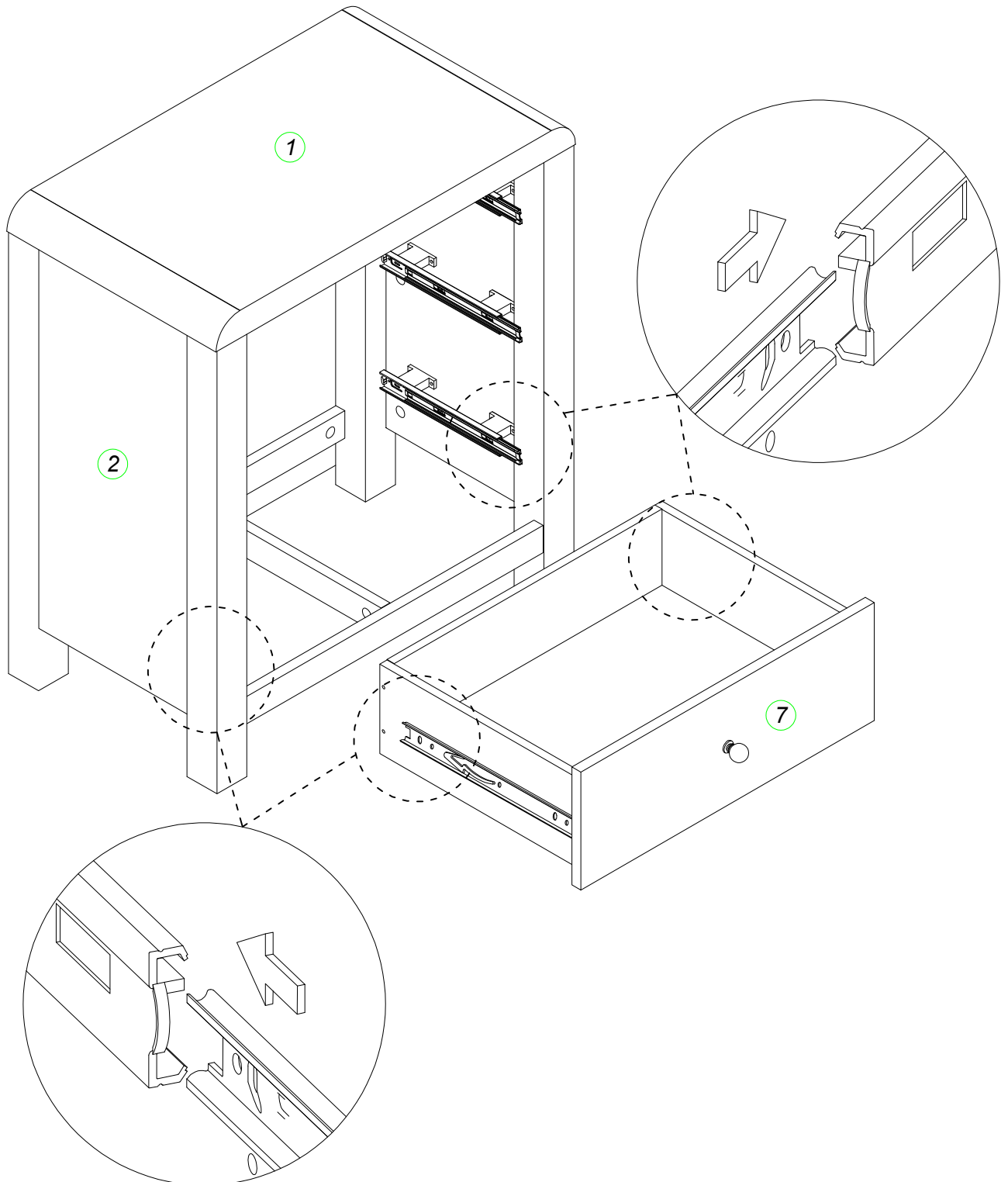

STEP 22 Please tighten the screws after completing all installation.

Por favor, apriete los tornillos después de instalar todo.

Assemble one by one drawer from bottom to top /
Assemblez un par un tiroir du bas à Retour au début /
Ensamblar uno por uno cajón de abajo hacia arriba.

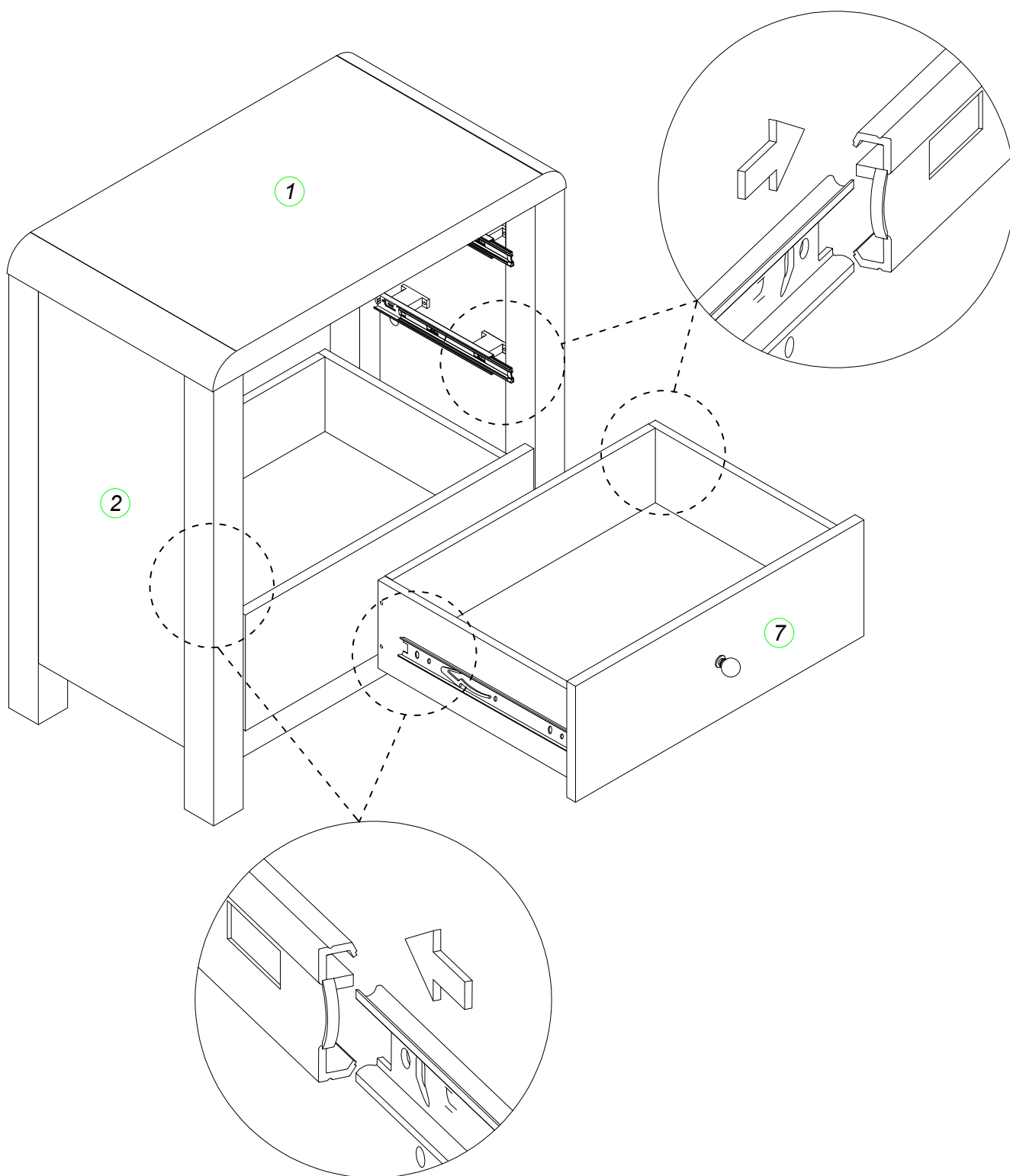

STEP 23 Please tighten the screws after completing all installation.

Por favor, apriete los tornillos después de instalar todo.

Assemble one by one drawer from bottom to top /
Assemblez un par un tiroir du bas à Retour au début /
Ensamblar uno por uno cajón de abajo hacia arriba.

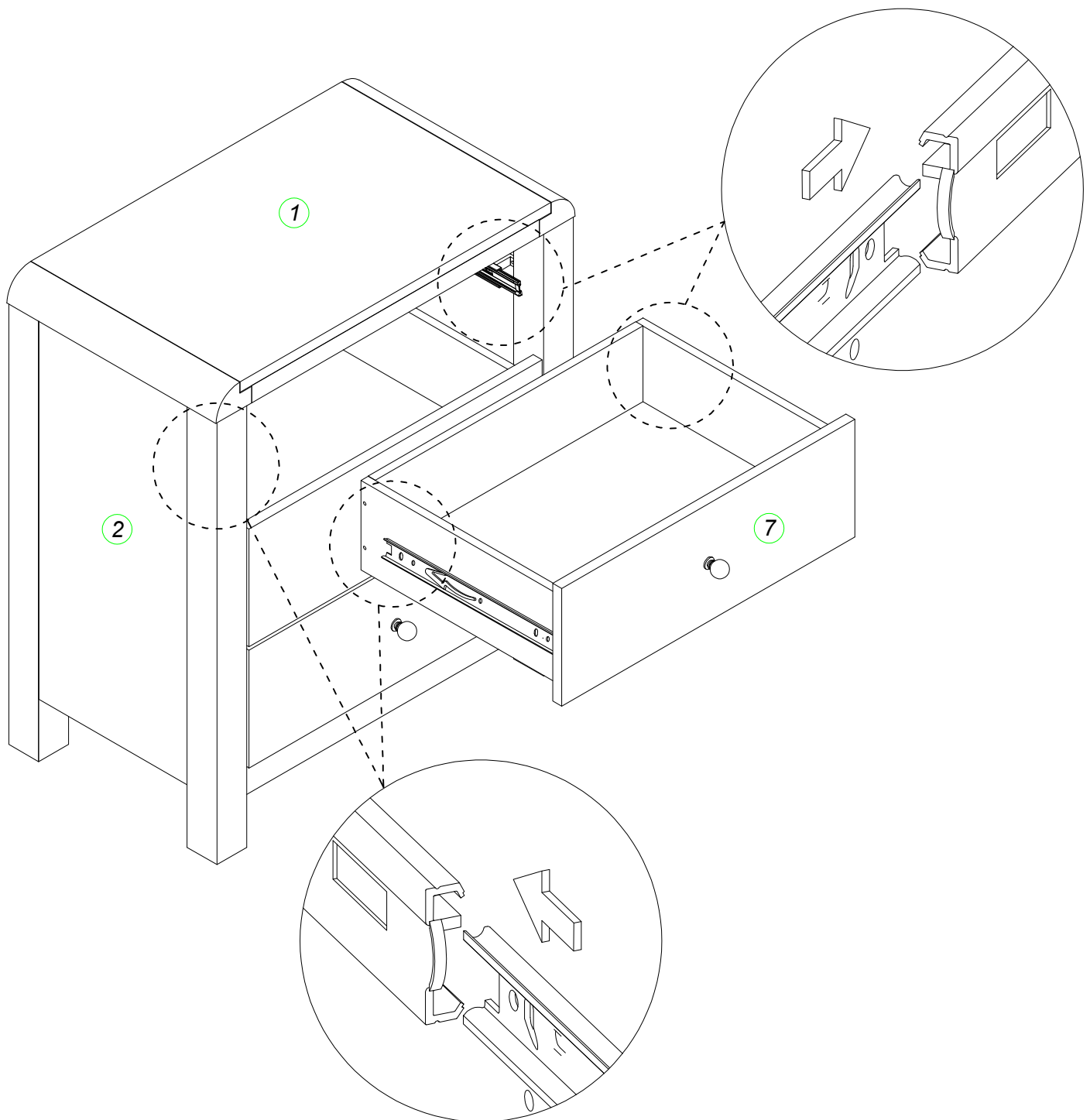

ASSEMBLY COMPLETE



MAINTENANCE AND CARE

Prevent Moisture Damage:

Safeguard your laminate furniture by keeping it in a dry environment. Store the furniture away from damp areas and water sources.

Sunlight Shielding:

Shield your laminate furniture from direct sunlight to prevent color fading and surface deterioration. Consider using curtains or blinds for protection, especially if direct sunlight exposure is unavoidable.

Regular Care:

Maintain your laminate furniture's appearance by gently wiping surfaces with a damp cloth. Avoid using overly wet cloths or abrasive cleaning tools.

Avoid Scratches:

Protect the furniture surface from scratches by refraining from placing sharp or hard objects on it. When moving the furniture, be cautious not to scrape the legs against the floor.

Proper Weight Distribution:

Prevent structural damage by placing heavy objects on stable support surfaces rather than directly on the laminate furniture's surface. This simple step can prolong the life of your furniture.



MANTENIMIENTO Y CUIDADO

Evite daños por humedad:

Proteja sus muebles laminados manteniéndolos en un ambiente seco. Guarde los muebles lejos de zonas húmedas y fuentes de agua.

Protéjalos de la luz solar:

Proteja sus muebles laminados de la luz solar directa para evitar la pérdida de color y el deterioro de la superficie. Considere el uso de cortinas o persianas como protección, especialmente si la exposición directa a la luz solar es inevitable.

Cuidado regular:

Mantenga el aspecto de sus muebles laminados limpiando suavemente las superficies con un paño húmedo. Evite utilizar paños demasiado húmedos o herramientas de limpieza abrasivas.

Evite los arañazos:

Proteja la superficie del mueble de arañazos evitando colocar objetos afilados o duros sobre ella. Al mover el mueble, tenga cuidado de no raspar las patas contra el suelo.

Distribución adecuada del peso:

Evite daños estructurales colocando objetos pesados sobre superficies de apoyo estables en lugar de directamente sobre la superficie del mueble laminado. Este sencillo paso puede prolongar la vida de sus muebles.



WARRANTY INFORMATION

Warranty Coverage: Our warranty provides protection against manufacturing defects in materials and workmanship for a specified period from the date of purchase, as outlined in the accompanying warranty documentation.

Exclusions: The warranty does not cover damages resulting from misuse, negligence, accidents, normal wear and tear, unauthorized repairs or modifications, improper assembly, or failure to adhere to the care and maintenance guidelines provided.

WARRANTY CLAIM PROCESS

To initiate a return, please follow these steps:

1. Log into your account and go to the "Your Orders" section.
2. Locate the order containing the item you wish to return.
3. Contact our customer service for assistance in obtaining a prepaid return label.
4. Once you receive the return label, securely affix it to the package.
5. You can then choose to drop off the package at a designated carrier location or arrange for a pickup.
6. After we receive and inspect the returned product, we will initiate the refund process.
7. The refund will be credited back to the original payment method used during the purchase.
8. Typically, refunds are processed within 3-5 business days.



Cobertura de la garantía: Nuestra garantía proporciona protección contra defectos de fabricación en materiales y mano de obra durante un período determinado a partir de la fecha de compra, como se indica en la documentación de garantía adjunta.

Exclusiones: La garantía no cubre los daños resultantes de uso indebido, negligencia, accidentes, desgaste normal, reparaciones o modificaciones no autorizadas, montaje incorrecto o incumplimiento de las directrices de cuidado y mantenimiento proporcionadas. las directrices de cuidado y mantenimiento proporcionadas.

PROCESO DE RECLAMACIÓN DE LA GARANTÍA

Para iniciar una devolución, siga estos pasos:

1. Accede a tu cuenta y ve a la sección "Tus pedidos".
2. Localiza el pedido que contiene el artículo que deseas devolver.
3. Ponte en contacto con nuestro servicio de atención al cliente para que te ayuden a obtener una etiqueta de devolución prepagada.
4. Una vez que reciba la etiqueta de devolución, fijela firmemente al paquete.
5. A continuación, puede optar por depositar el paquete en el lugar designado por el transportista o solicitar que lo recojan.
6. Después de que recibamos e inspeccionemos el producto devuelto, iniciaremos el proceso de reembolso.
7. El reembolso se abonará de nuevo al método de pago original utilizado durante la compra.
8. Normalmente, los reembolsos se procesan en un plazo de 3 a 5 días laborables.