

Lift Recliner Assembly Instruction

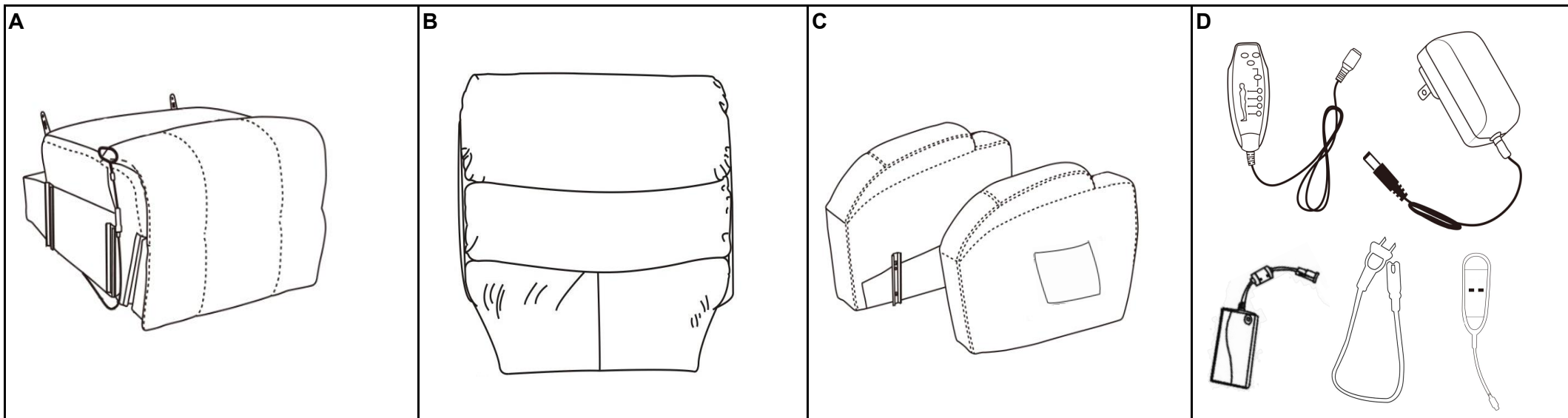

Chair base

Backrest

Left and right armrest

Massage and lift remote control and Power cord

Step 1:

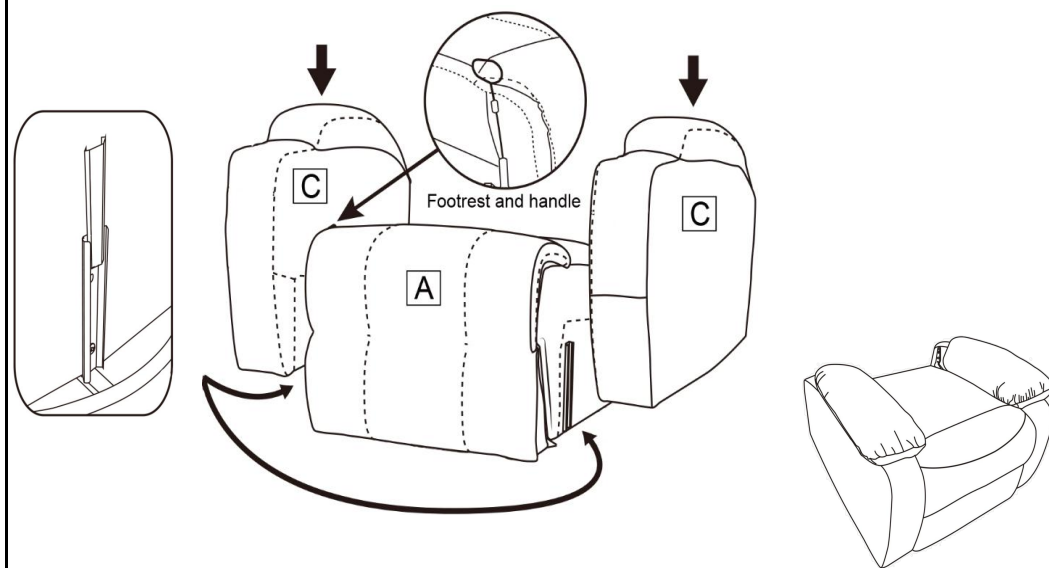

Position the armrest, Put the armrests fits into the seat, you will hear a "click" when it is in place.

Step 2:

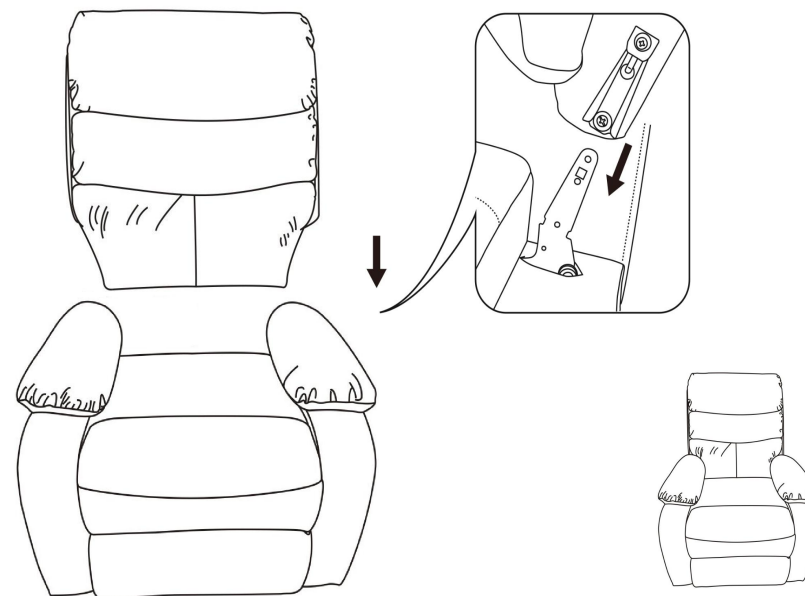

Insert the back on the seat. Gently push down until the back locks into position.

Lift Recliner Assembly Instruction

Step 3:

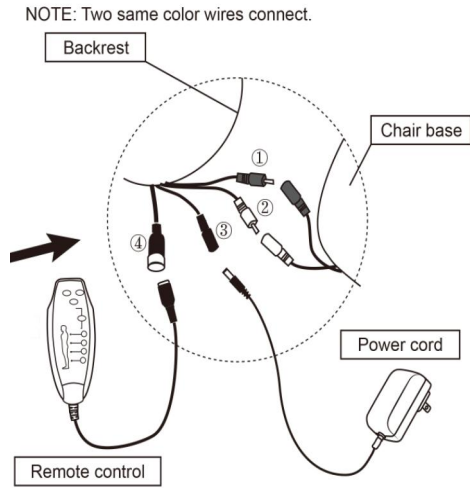
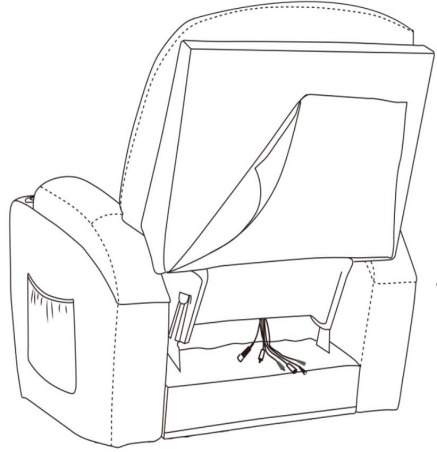

- No.1 and No.2 wire connect with the backrest and chair base.
- No.3 wire connects with backrest and power cord(Big).
- No.4 wire connects with backrest and massage remote control.

How to use remote control?

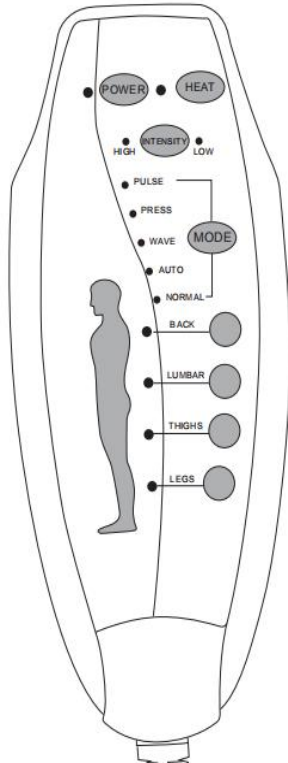

POWER : Turn on/off remote control

HEAT : Turn on/off heat function for lumbar part only.

INTENSITY : Control massage function from low to high

MODE : Choose one massage mode you like(pulse, press,wave,auto, normal)

You can choose 1-4 massage parts(back, lumbar, thighs, legs)to enjoy.

Lift Recliner Assembly Instruction

Step 3:

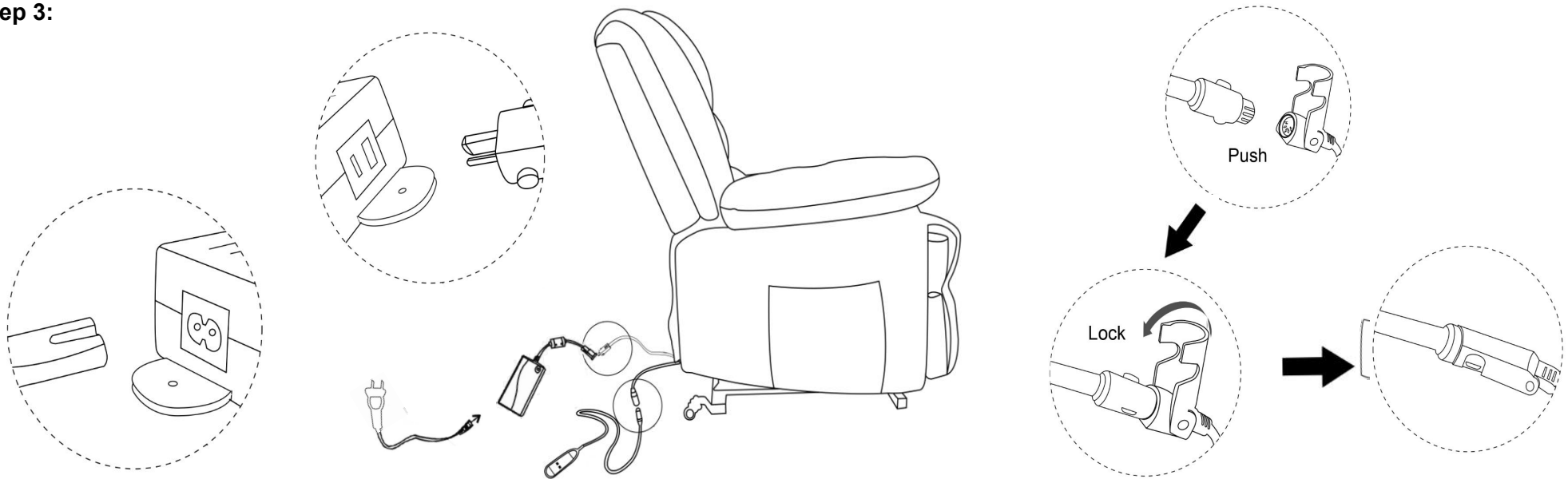

Connect the supply cable pins. Fits the pins properly in the manner shown in the image. Do not force them, they only have one correct position. Please keep all wires coming out at the bottom of the frame

Instruction of Lift Remote Control

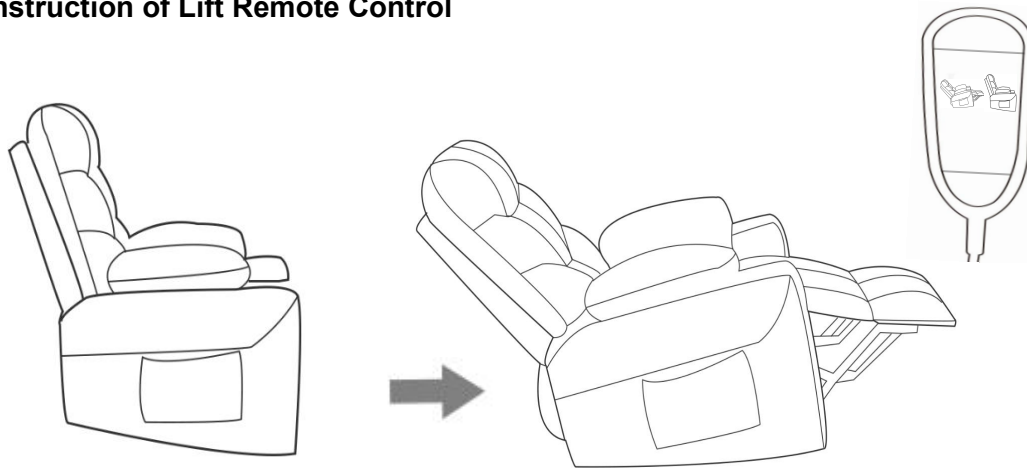

1. Please press the button , the backrest will move down the legrest will rise up.

If you keep pressing the button, the lift chair will rise up and forward until it elevates you a standing position.

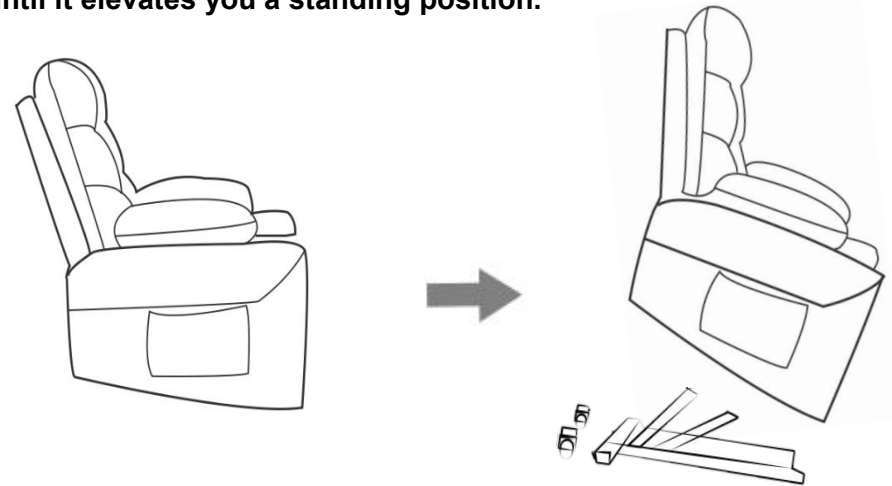

2. Please keep pressing the button , the backrest legrest will rise up, the legrest will move down. the lift chair will return from reclining position to normal position

Lift Recliner Assembly Instruction



Warning!

The pins must be connected correctly.

If the lift chair doesn't work when you finally turn it on, it is because the pins have been connected incorrectly.

If that should happen, turn the power off and reconnect the pins.

Never set the lift chair in wet / damp areas or where dust can accumulate because these could cause an electrical fault or a mechanical dysfunction.

Never use the lift chair inside your home if the room temperature is over 90°F.

Never place the lift chair near a heat source (oven, chimney, furnace etc...) or in direct sunlight

Do Not use the armchair if:

The lift chair is wet.

Your hands are wet.

Clean the chair with a wet cloth.

Situations where you should not use the lift chair:

Switch the lift chair if any part of the lift chair is damaged or malfunctioning, if any part of the lift chair appears to be damaged or wiring is exposed.

Usage:

Indoors, avoid high temperatures and wet or damp areas.

Precaution:

Never sit on the remote or place heavy objects on top of it.

Do not drop the remote on the floor.

Do not tug on the electric cable.

Do not use the remote with wet fingers.

Do not press or touch the buttons with sharp objects.

Never unplug the remote without first turning the power off.

The lift chair should rest for 30 minutes after it has been used for 30 minutes.

Can't massage or heat:

There are four reasons lead to no massage and heat.

(1) Power cord problem, please make sure the indicator lit.

(2) Remote control problem, please make sure the indicator lit.

(3) Please check this manual and make sure power cord and remote control connect to the right wire(there are 4 wires need to be connected).

(4)The wires inside the chair is damaged, which we check every chair before shipped out to make sure it's ok.

Note:

Please try to solve the problem by the way above, feel free to send the email to us for further help if it's still unavailable.

We will try our best to help you solve your any concerns!