

Assembly Instructions

Caution: You must read this before you proceed

Please look under the Table Top for hardware packs

Table

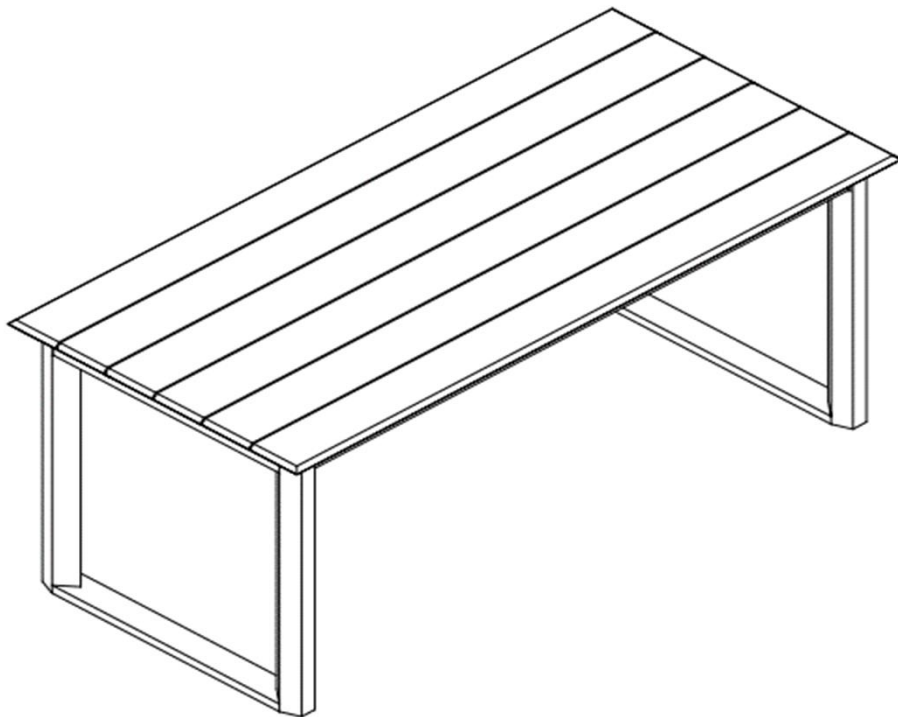





Caution: This Table is NOT a TOY.





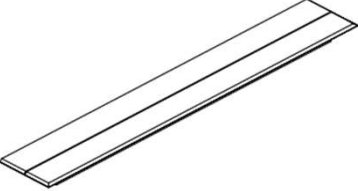
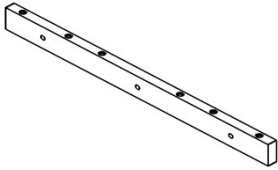
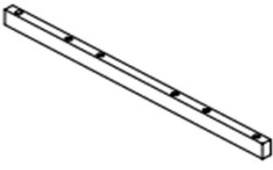

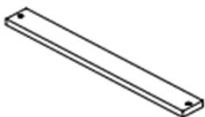
Keep your child/children at bay during the assembly process.

Whenever moving/lifting the Table and to prevent damage to the Table, two adults are required to execute these actions.

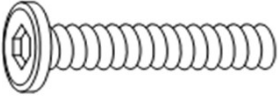
Part List

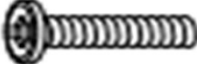
Label	Picture	Description	QTY
A		Left Table Top	1
B		Center Table Top	1
C		Right Table Top	1
D		Side Support Bar	2
E		Center Support Bar	4
F		Leg	4
G		Support Leg	2





Hardware

Label	Picture	Description	QTY
①		Bolt (M8x60mm)	9
②		Screw (M6x70mm)	17
③		Screw (M6x55mm)	25
④		Bolt (M6x30mm)	7
⑤		Spring Washer (M8.5/10.5X2mm)	9
⑥		Flat Washer (M8.5/20x2mm)	9
⑦		Allen Wrench	2

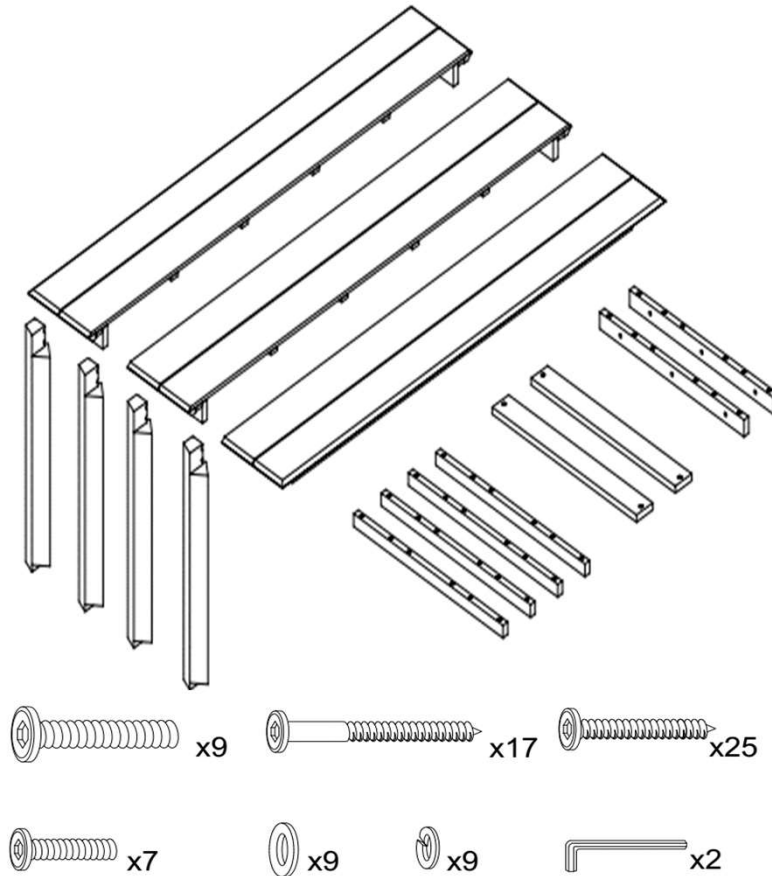
Assembly Preparation

Before Beginning Assembly:



-  • Read instructions, cover to cover-
-  • Have 2 adults on hand for assembly-
-  • Do not assemble on flooring or carpet-
-  • Assemble on a clean non-marring surface (packing foam)-
-  • Save all packaging until finished-

Assembly Steps

Overview

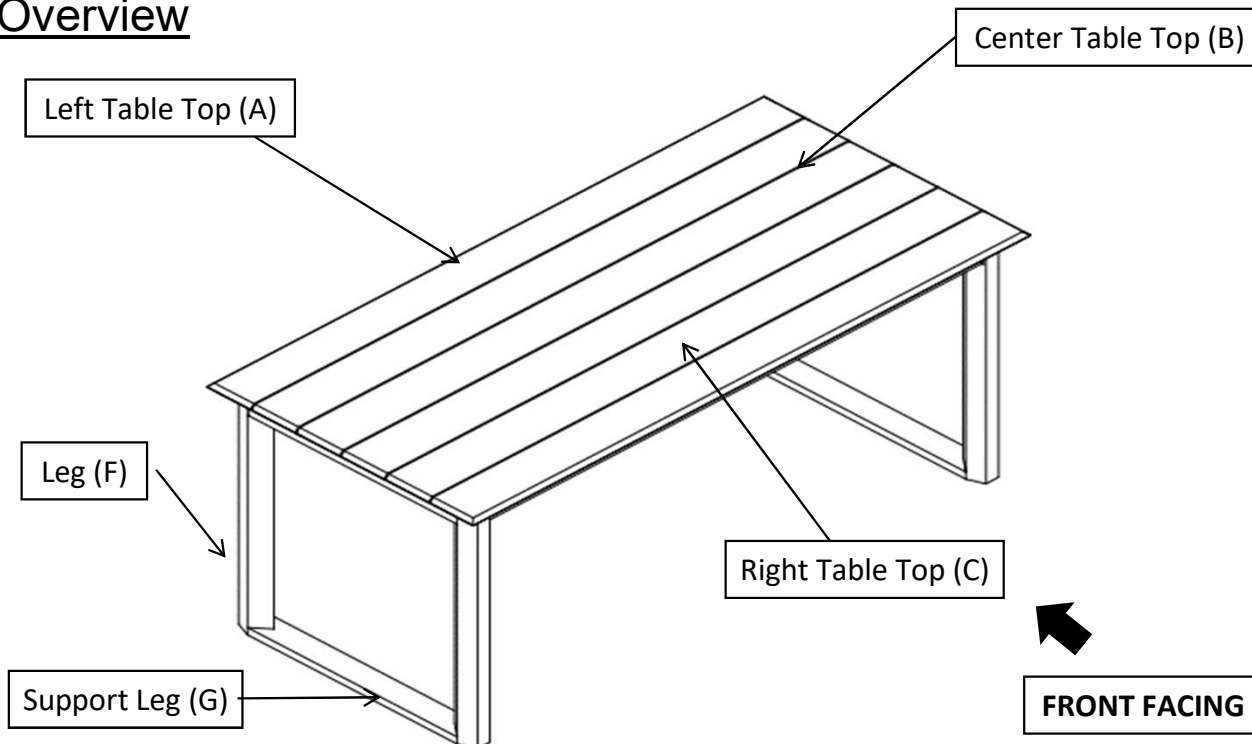

This Table has multiple parts and may require up to 30 minutes to assemble. To give you an overview of the Table parts, the above picture is to help you put the various parts into perspective. Please read through the instructions below to familiarise yourself with the parts and steps before assembly.

Step 1

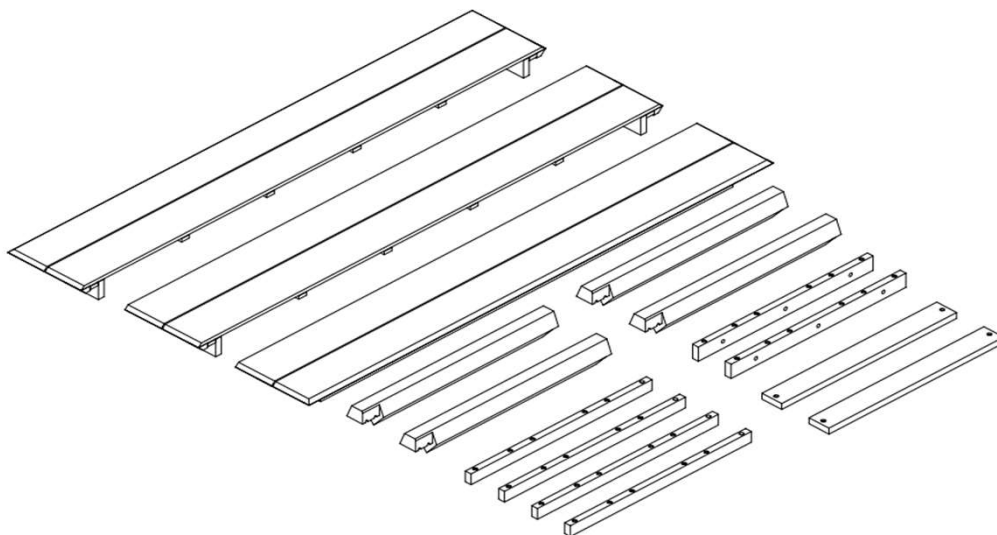

Unpack and place all parts on a clean, non-marring surface.

Step 2

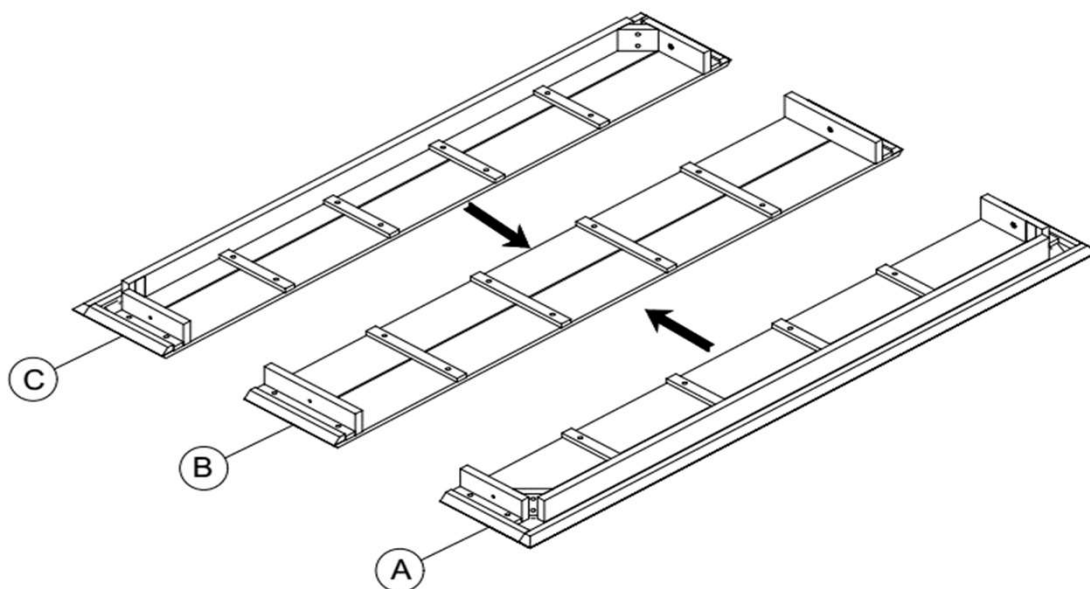

With assistance from your adult partner, place the Left Table Top (A), the Center Table Top (B), and the Right Table Top (C) facedown on a clean, non-marring surface.

Make sure the Left Table Top (A) and the Right Table Top (C) are aligned with the Table Center Top (B) as pictures shown above

Step 3

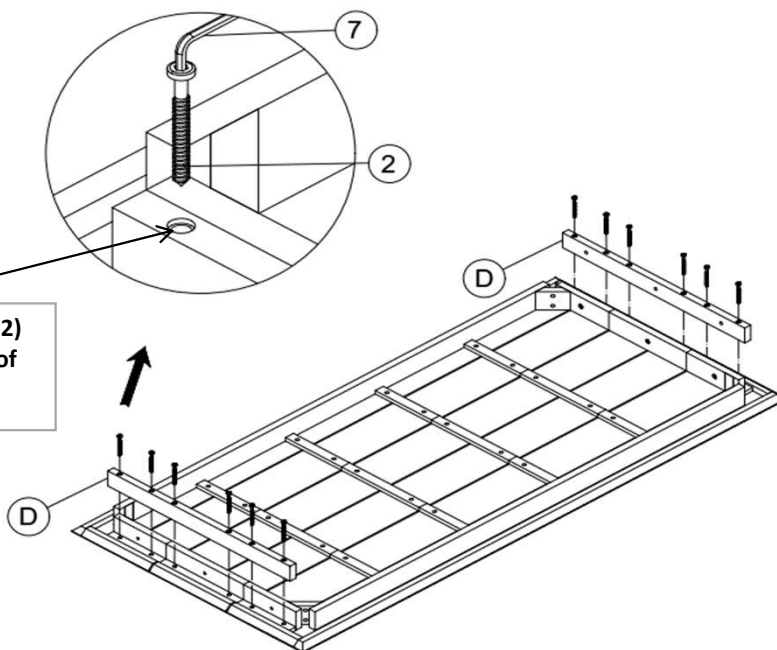

Attention: Drive Screws (2) from the bigger housing of Side Support Bar (D)

Attach the Side Support Bar (D) into the shorter side of the Table Top using Screws (2) and the Allen Wrench (7) as shown in the picture above.

Repeat the same process with the remaining Side Support Bar (D)

Do not fully tighten the Screws.

Step 4

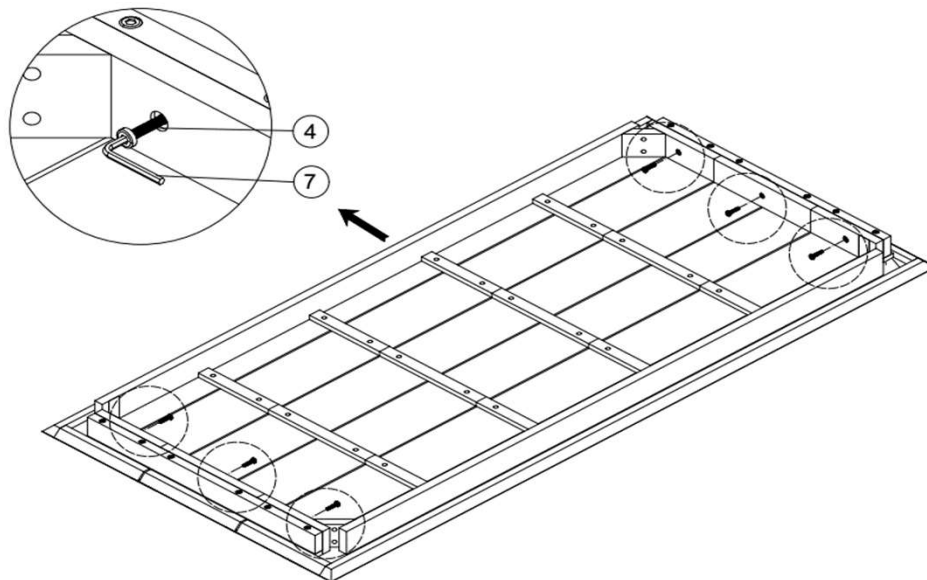

Secure a Side Support Bar (D) to the apron of the Table Top using Bolts (④) and the Allen Wrench (⑦) as shown in the picture above.

Repeat the same process with the remaining Support Bars (D)

Do not fully tighten the Bolts.

Step 5

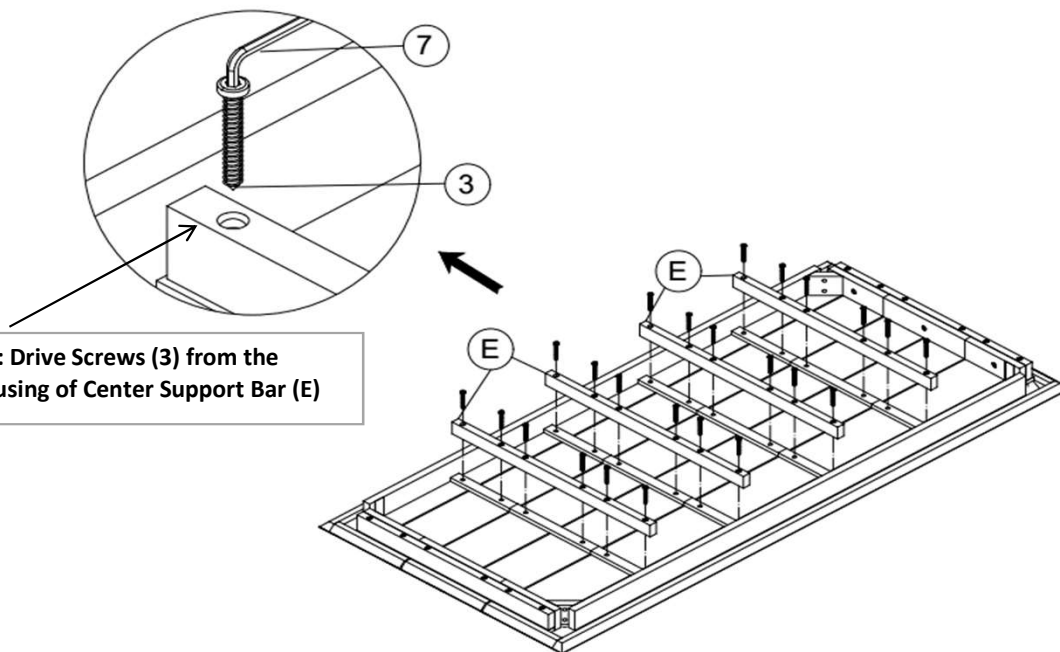

Attach a Center Support Bar (E) into the Table Top using Screws (③) and the Allen Wrench (⑦)

Repeat the same process with the remaining Center Support Bars (E)

Do not fully tighten the Screws.

Step 6

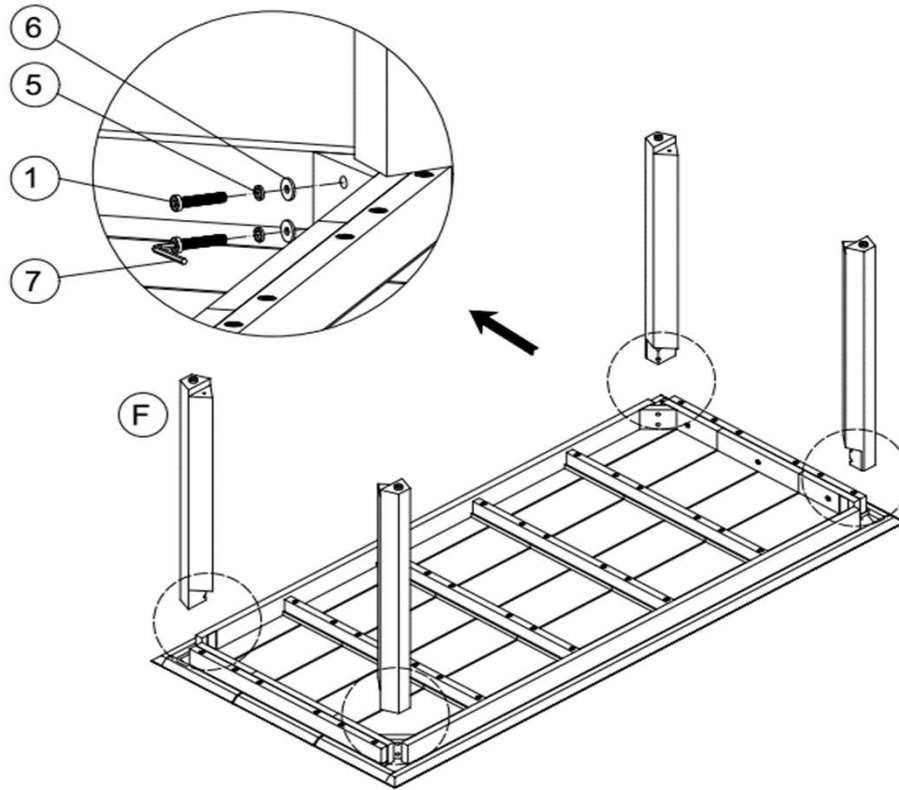

Attach a Leg (F) into the Table Top using Bolts (①), Spring Washers (⑤), Flat Washers (⑥) and the Allen Wrench (⑦)
Repeat the same process with the remaining Legs (F)
Do not Fully tighten the Bolts

Step 7

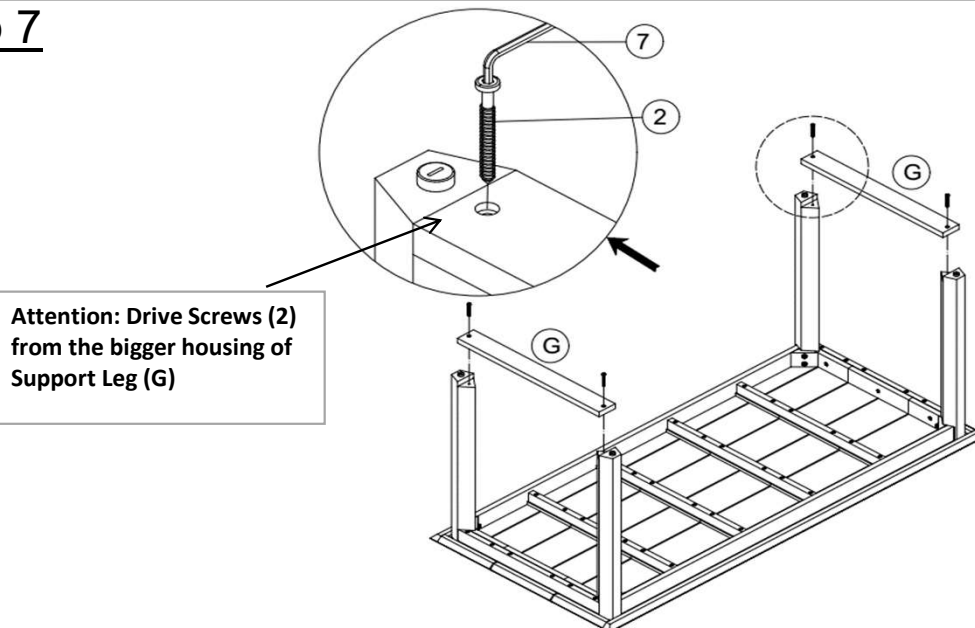

Attach a Support Leg (G) into Legs (F) by using Screws (②) with the Allen Wrench (⑦)
Repeat the same process with the remaining Support Legs (G)
Do not Fully tighten the Screws

Step 8

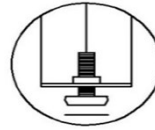
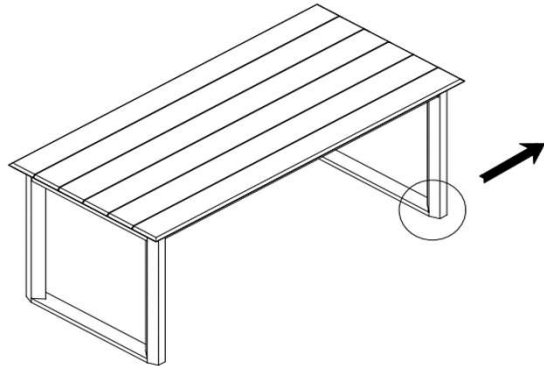

Adjust high for balance

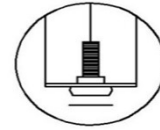

Adjust low for balance

Adjust Pre-installed Levelers

With assistance from your adult partners, Turn the Table right side up.

EXERT pressure, floorwards onto the Table with both hands.

This pressure will help the Table reach full alignment at all joints. Check for wobbles.

In a sequential manner, gradually tighten all Bolts and Screws at all joints until evenly secured.

Inspect the Table and make sure all parts are adequately connected.



















Do not tighten any Bolt or Screw fully and then move on towards the next one.

With assistance from your adult partners, adjust the Levelers to the desired height to avoid wobbles.

Your Table is ready for use.

This Table can only be used on a flat, level surface.

Care & Maintenance

-   ● Do not put hot items directly on furniture surface
 -   ● Do not clean furniture with harsh cleansers or polish.
 -   ● To obtain the longest lifespan of your outdoor products, minimizing exposure to direct sunlight is recommended.
 -   ● Children should not climb or jump on the furniture.
 -   ● Do not write on furniture without a padded barrier to protect the surface.
 -   ● To obtain the longest lifespan of your outdoor products, avoid extended and lengthy exposure to rain, snow, and direct sunshine. Whenever possible cover the product and /or place under patio or awnings.
 -   ● Not for commercial use. For residential use only .
 -   ● Stains may be removed with mild soap solution and damp cloth.
-
-   ● Dust and pick-up spills using a clean, non-colored, lint-free cloth .