

ASSEMBLY INSTRUCTIONS

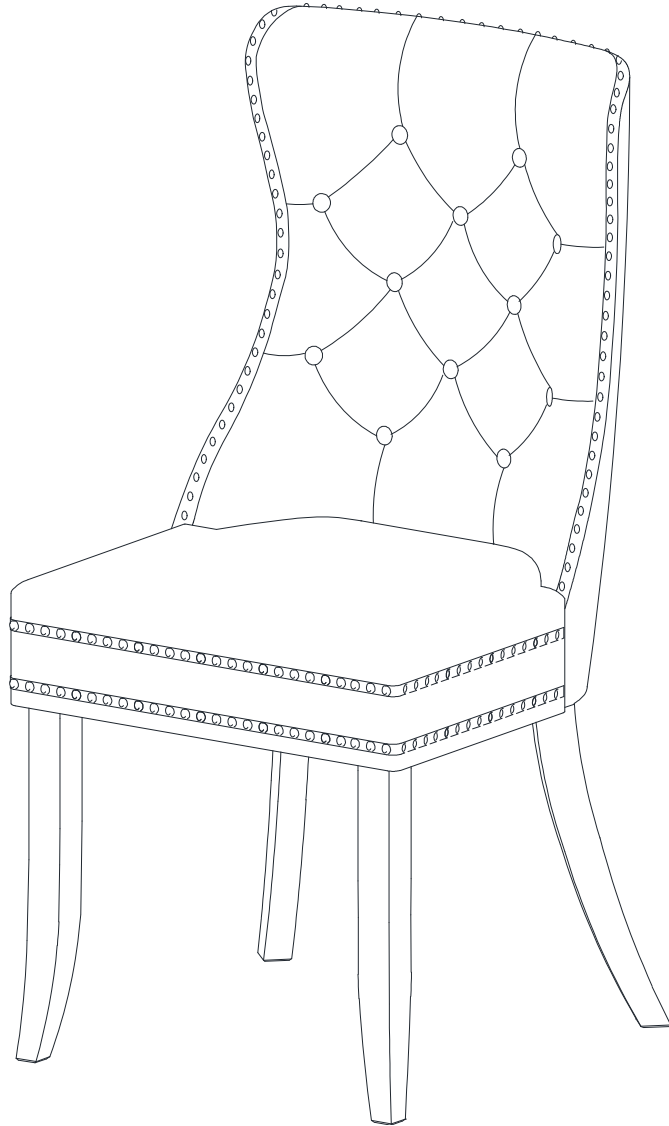

Product Dimension : 19.5"Wx23.8"Dx37.7"H

Cube Size : 52"x 22.2"x14.6" NW: 39.6 LBS

(Chair back) GW: 48.4 LBS

Cube Size : 19"x 15.7"x 3" NW: 5.5 LBS

(Legs) GW: 6.6 LBS

BEFORE ASSEMBLY

Thank you for purchasing our product. This product has been designed for easy assembly and long-lasting use. Please take the time to read and follow the assembly instructions carefully.

Be sure to check all packing material carefully for small parts that may have come loose inside the carton during shipment. Please separate, identify, and count all parts and metal hardware. Compare with the part list to be sure all parts are present. If the hardware is missing or you have difficulty assembling this product, please call for us.

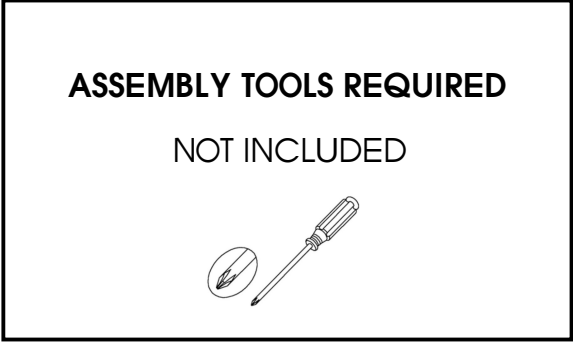

IMPORTANT NOTE:

- Place all wooden parts on a clean and smooth surface such as a rug or carpet to avoid the parts from being scratched.
- Remove all wrapping material, including staples & packing straps, before you start to assemble.
- DO NOT tighten all screws and bolts until completely assembled.
- Keep all hardware parts out of reach of children.





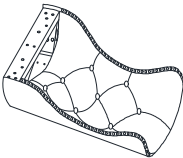
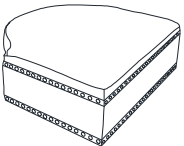



PART LIST

When unpacking, please be careful not to discard any parts with the packaging. Before continuing, please make sure you have the following parts:

NO	Description	Qty	Sketch	NO	Description	Qty	Sketch
A	Chair back	1		B	Seat Frame	1	
C	Front Leg	2		D	Back Leg	2	

HARDWARE LIST

When unpacking, please be careful not to discard any parts with the packaging. Before continuing, please make sure you have all of the following hardware:

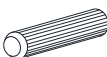
NO	Description	Qty	Sketch	NO	Description	Qty	Sketch
1	Long bolt (M6x60mm)	4		2	Medium bolt (M6x50mm)	4	
3	Short bolt (M6x45mm)	4		4	Lock Washer (Ø6.5xØ9)	12	
5	Flat Washer (Ø6.5xØ19)	12		6	Allen Key (4mm)	1	
7	Dowel (Ø10x30)	2					

STEP 1

Remove the bottom cover out of the seat frame (B) as shown below, then attach dowel (7) to seat frame (B).

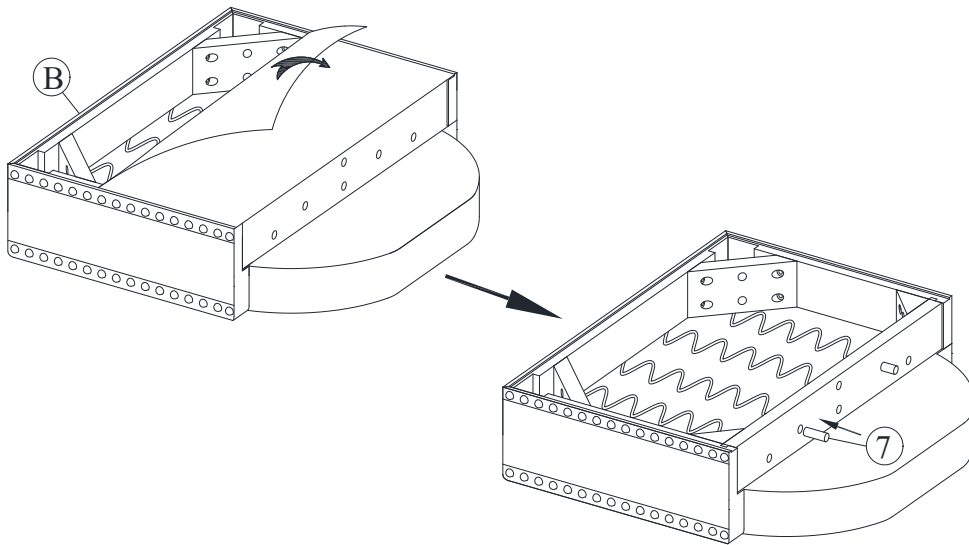

STEP 2

Attach the front legs (C) to the seat frame (B) by using bolts (1), lock washers (4) and flat washers (5), then tighten with Allen Key (6).

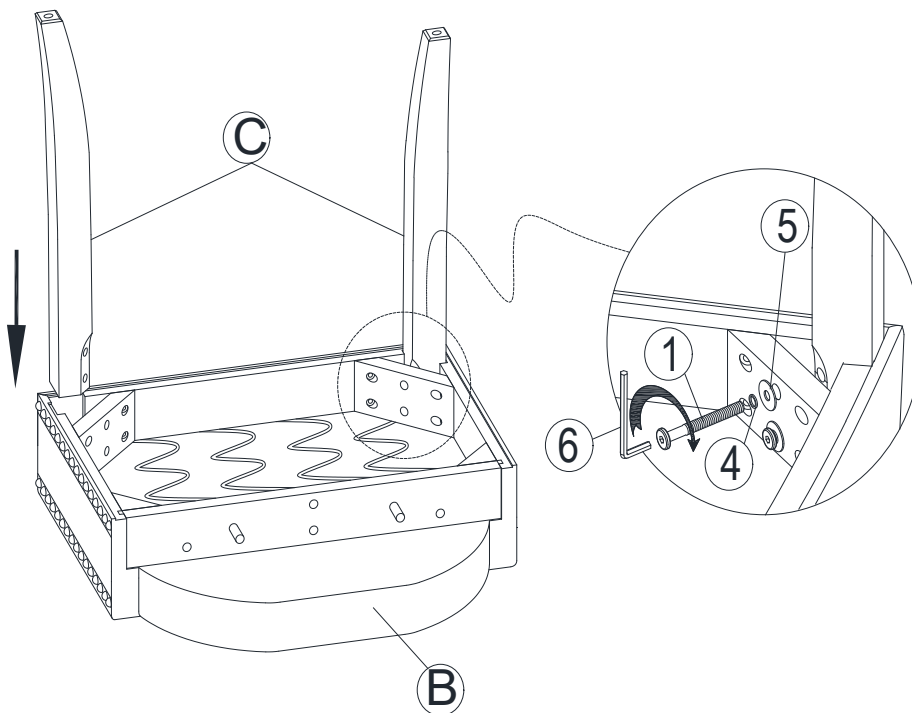

STEP 3

Attach the back legs (D) to the chair back (A) by using bolts (2), lock washers (4) and flat washers (5), then tighten with Allen Key (6).

Note: DO NOT fully tighten any of the bolts until the chair assembled with all parts.

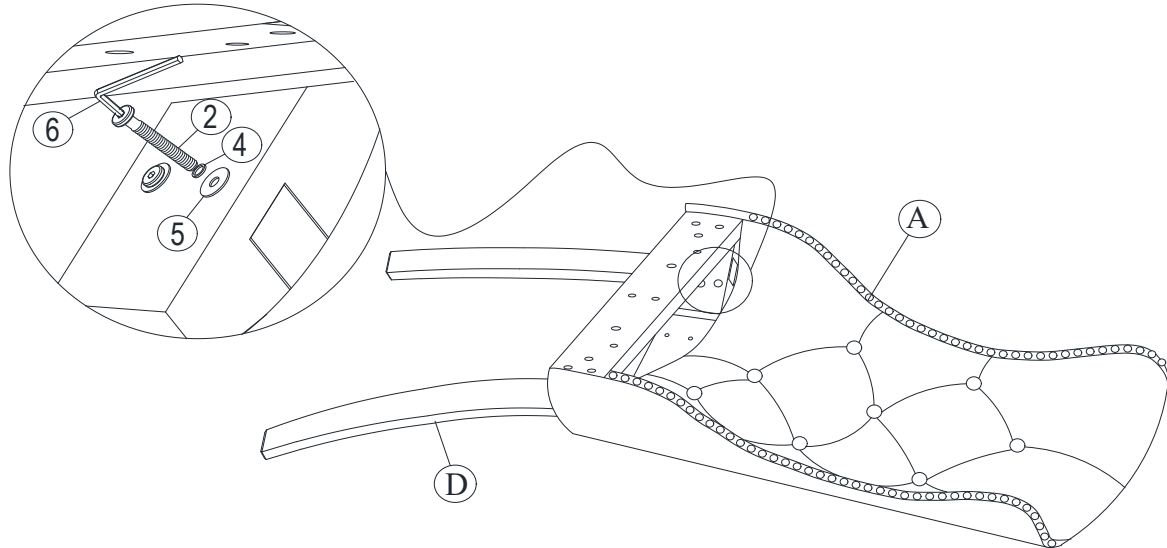

STEP 4

Attach the seat frame (B) to the chair back (A) by using bolts (3), lock washers (4) and flat washers (5), then tighten with Allen Key (6).

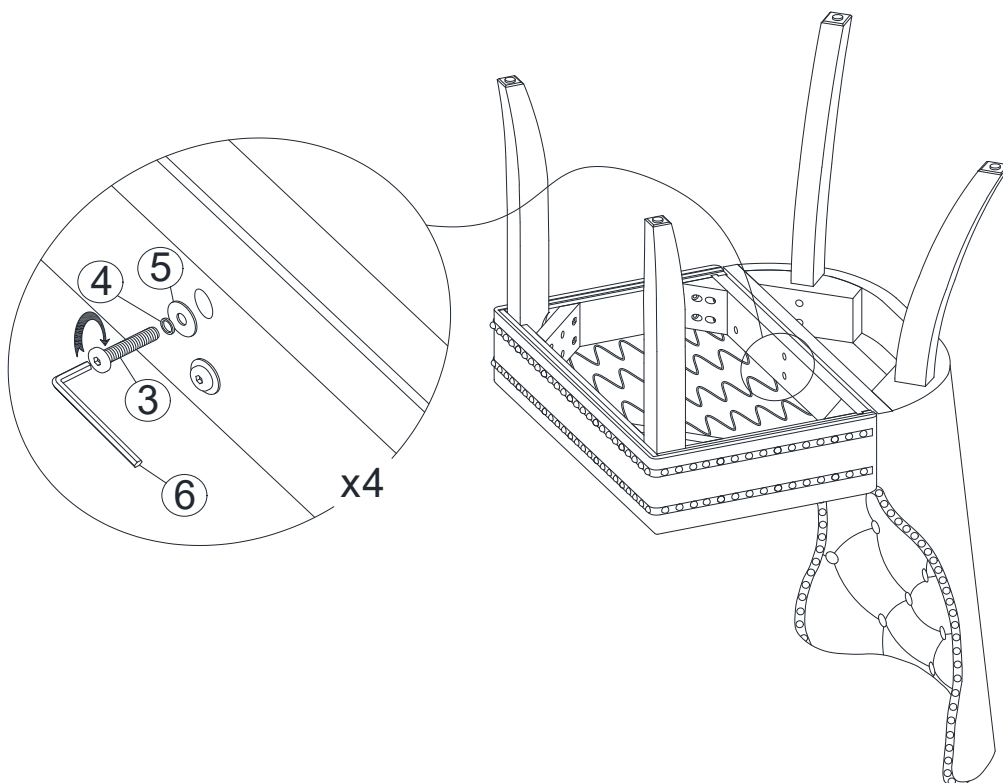

STEP 5

Place the chair on a flat level surface to make sure the chair is level and then tighten all bolts.

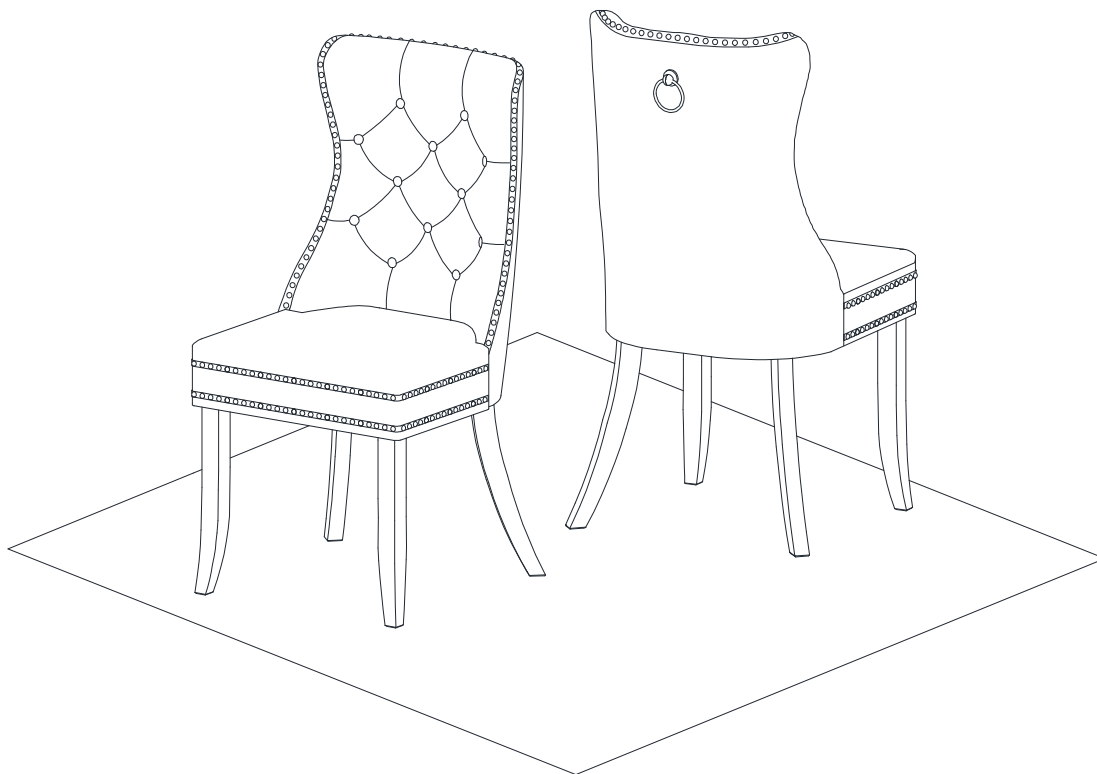

STEP 6

Attach the bottom cover (removed on step 1) back on the seat frame and finish the assembly.

