

## **NUV - Towel Hook**

### **installation instructions**

#### **Guarantee terms:**

DABSTORY s.c. provides a consumer guarantee for DABSTORY s.c. products under the name **NUV**. The guarantee covers only defects arising from causes inherent to the product sold. The guarantee period is 2 years from the date of purchase. The guarantee in no way excludes, suspends or limits the rights arising from the provisions of the warranty for defects of the sold item. If a product is found to be defective, the consumer may file a complaint via email correspondence to: [info@dabstory.com](mailto:info@dabstory.com) or through the dedicated form available at [https://dabstoryshop.com/data/include/cms//GOODS\\_RETURN\\_FORM\\_ENG.pdf](https://dabstoryshop.com/data/include/cms//GOODS_RETURN_FORM_ENG.pdf). In the complaint application you must provide: first and last name, telephone number, e-mail address, proof of purchase of the product, a detailed description of the defects along with photographic documentation (if possible). DABSTORY s.c. shall respond to the submitted complaint within 14 days of its receipt in the form of electronic correspondence to the e-mail ad-

dress provided or by phone. If it proves necessary to consider the complaint, the purchased product should be delivered, at the expense of the complainant, to the address DABSTORY s.c. ul. Gębicka 22, 62-200 Gniezno. If the complaint is accepted, DABSTORY s.c. shall remove the defects within 14 days or replace the purchased goods with goods free from defects, if the defects do not qualify for removal. The guarantee does not cover damage to the product resulting from improper installation, use, cleaning or maintenance, as well as damage resulting from fortuitous events (e.g. fire), caused by chemical substances, mechanical damage resulting from the operation of the product, damage resulting from excessive load on the product and those resulting from failure to follow the installation instructions. This guarantee excludes wear and tear arising from normal use of the product. The guarantee does not apply to products purchased as inferior or discounted, and those in which any alterations have been made without the consent and knowledge of DABSTORY s.c. DABSTORY s.c. shall not be liable for any damages or defects beyond the scope of the guarantee. The guarantee is valid worldwide.

## **General installation rules:**

Before installation, please read the steps in the instructions and product maintenance. It is imperative to follow the order of the installation steps with the general installation rules:

- Do not install items in case of finding defects or damage to purchased items.
- Check whether the surface (wall) is suitable for mounting suggested by the manufacturer, i.e. on double-sided adhesive tape. It is possible to glue the hook to ceramics, PVC, aluminum and varnished wood.
- The surface for gluing the hook must be smooth. A rough or uneven surface is not suitable.

## **Maintenance and use:**

During use of the towel hook, check the overall condition of the hanger as needed and that the securing tape does not peel from the surface of the hanger. Do not use rough sponges or components containing abrasives for cleaning. This may cause tarnishing or scratching of the surface. Do not use cleaners containing solvents, acids, or cooking vinegar. Test the cleaning agent on an inconspicuous area of the product first. Clean the surface of the hook with a soft cloth or paper towel.

NOTE!!! Excessive load on the hook creates a hazard during use and poses a threat of permanent damage.

# 1 Preparation stage



**Prepare your tools**

---

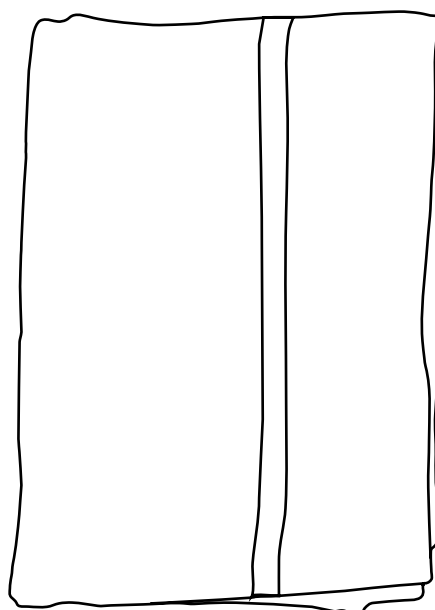
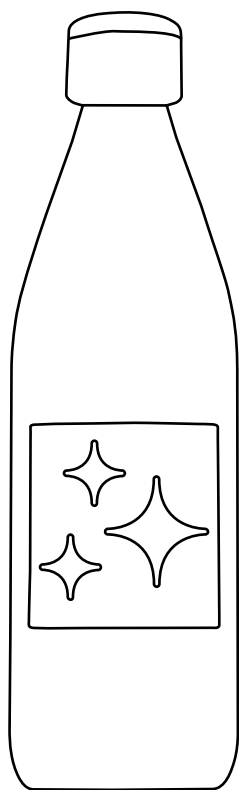

**Check the package contents**

---

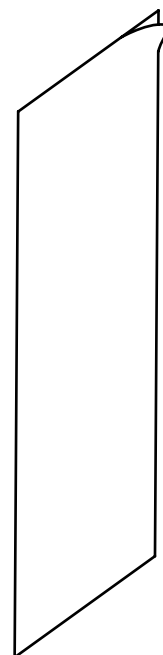
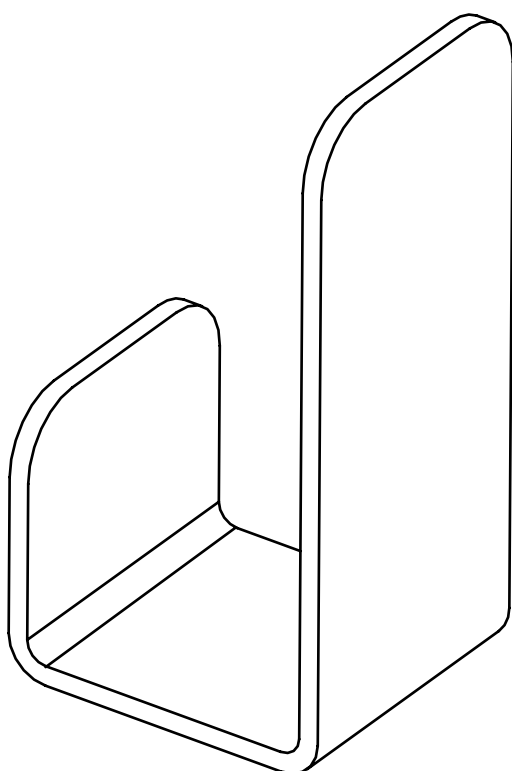

# 2 Installation stage

## A Degrease the surface

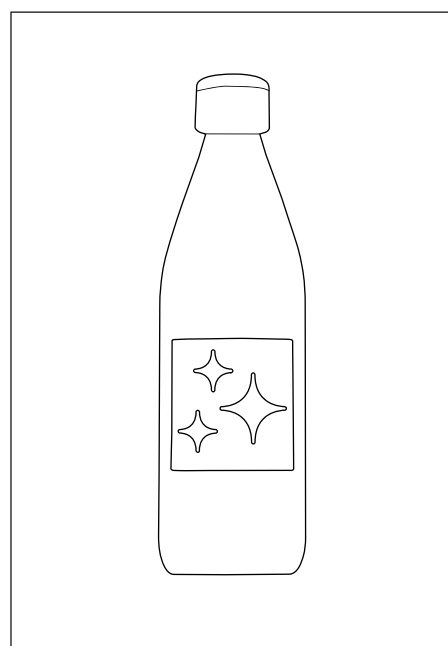
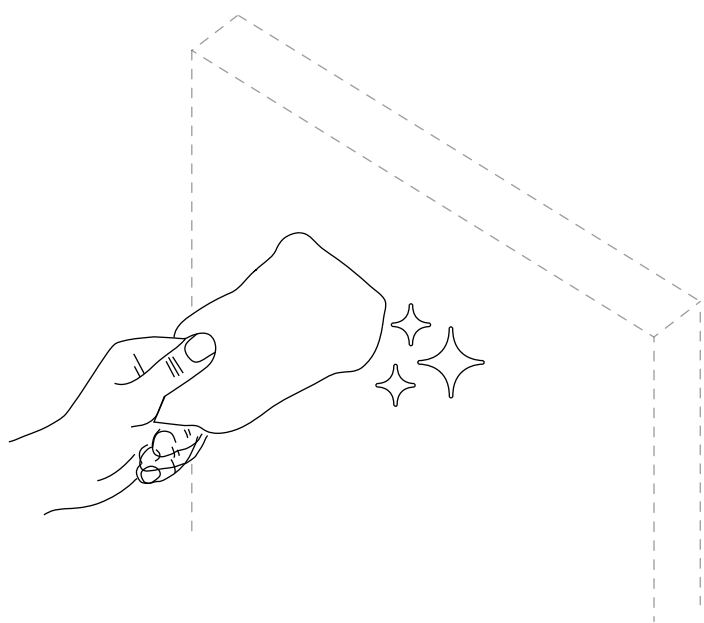

## B Glue the hook

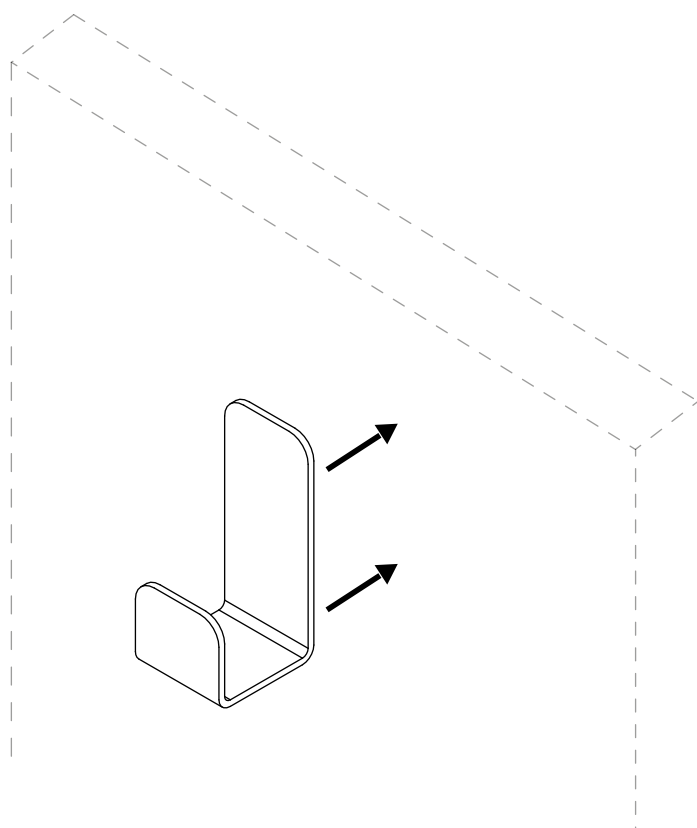
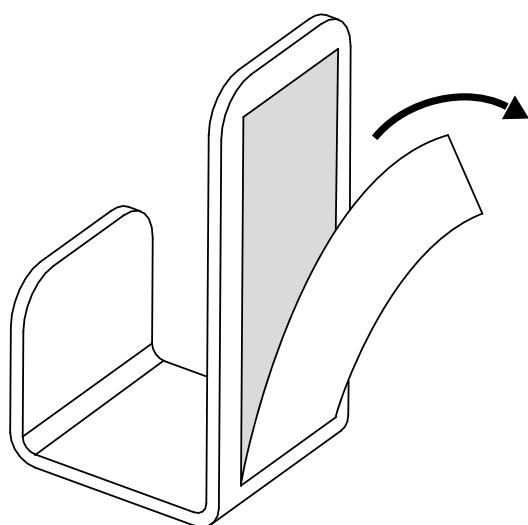

Leave the hook unloaded for 24 hours.



## **Manufacturer:**

DABSTORY S.C.

Ul. Wilczak 20F/37

61-623 Poznań

[www.dabstory.com](http://www.dabstory.com)

[info@dabstory.com](mailto:info@dabstory.com)

+48 608 885 045