

# Assembly Instructions

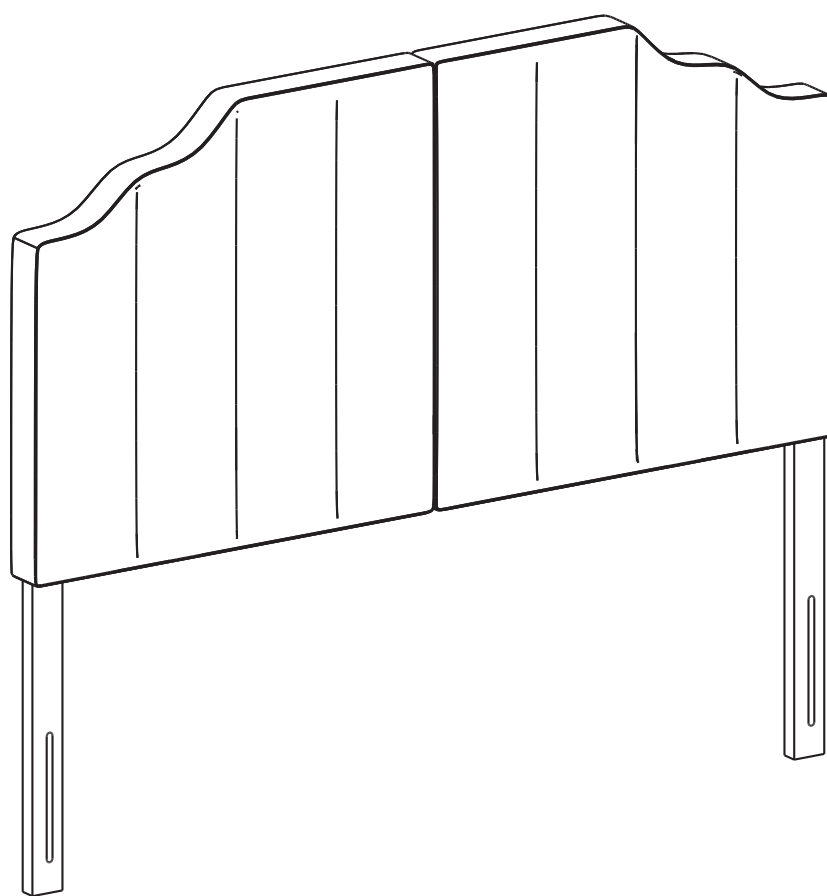

Please read this manual carefully before any operation and keep it properly for future use.

# LIFETIME LIMITED WARRANTY

## **WHAT IS COVERED**

This warranty covers any defects in materials or workmanship, with the exceptions stated below.

## **HOW LONG COVERAGE LASTS**

This warranty runs for as long as the original purchaser owns the product.

## **WHAT IS NOT COVERED**

The warranty applies only to the original purchaser and does not cover: (a) wear and tear; (b) improper maintenance, misuse, or alteration; (c) repair by unauthorized representatives; (d) damage resulting from transit or handling; or (e) transportation costs.

## **WHAT WE WILL DO**

We will repair, replace, or refund any product that proves to be defective in materials or workmanship.

## **HOW TO GET SERVICE**

E-mail us to submit your warranty claim. Please keep your receipt so that we may process your warranty request.

## **HOW STATE LAW APPLIES**

The foregoing warranty shall be exclusive and in lieu of any other warranty, express or implied, including warranties of merchantability and fitness for a particular purpose and all other warranties otherwise arising by operation of law, course of dealing, custom, trade, or otherwise. Neither the seller nor the manufacturer shall be liable for any injury, loss or damage, direct or consequential arising out of the use or inability to use this product.

# HEADBOARD ASSEMBLY INSTRUCTIONS

## PARTS LIST:

- (A) M6x35 bolts x8
- (B) Washers x2
- (C) Adapter x1
- (D) M8x55 bolts x2
- (E) Hex key x1
- (F) Pendant x2
- (G) Expansion screws x8
- (H) Butterfly screw cap x4
- (I) M6x60 bolts x2

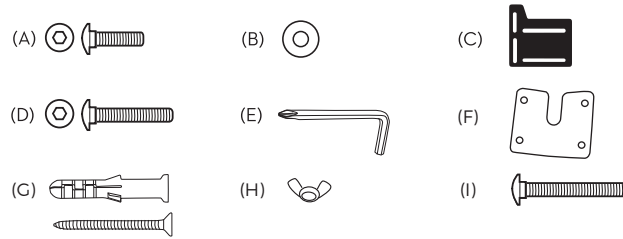

## STEP 1

Remove the headboard from the box and Lay the two headboards face down flat on the ground. Remove both legs and hardware from the straps on the back

Figure 1

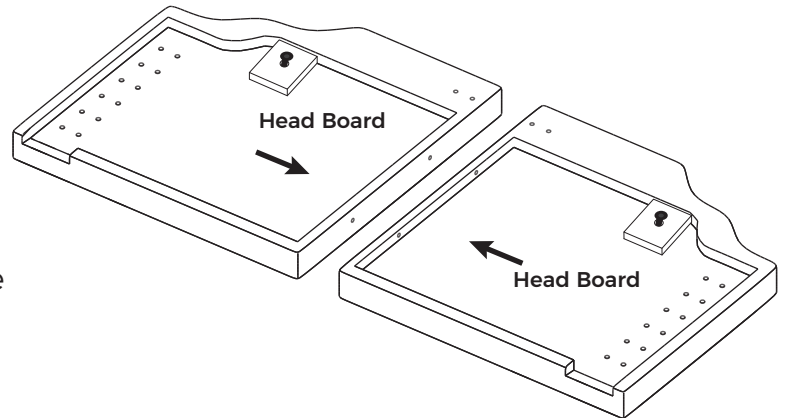

## STEP 2

Align the two headboards, use (C) metal connector, 4 (A) short bolts, 4 (B) washers to secure the upper end; And then fix the middle wood strip with 4(D) M6x35 bolts and 4 (B) washers. (see Figure 1 and 2)

Figure 2

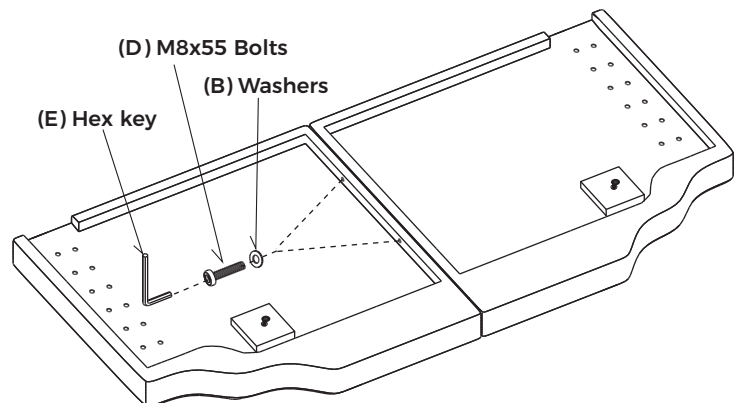

## STEP 3

Use two (D) M6x35 bolts, two (B) washers and, depending on the holes provided, attach each leg to the headboard using (E) Hex key at your desired height (see Figure 3)

Figure 3

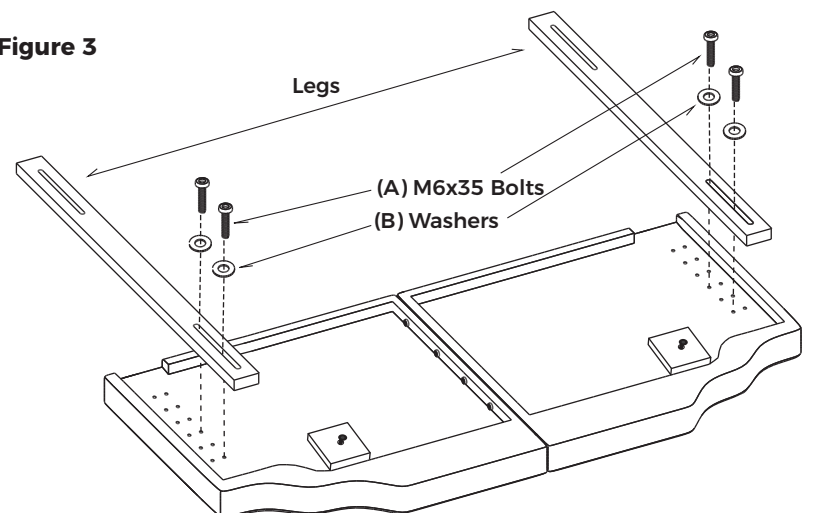

## The wall pendant

# ASSEMBLY INSTRUCTIONS

### STEP 1

Place assembled bed frame in front of head-board and position Adapter to determine which slots will line up with bed frame and headboard. Use provided lock nuts, small washers, and M6X35 bolts to attach Adapter to bed frame as shown in figure

### STEP 2

Use provided lock nuts, small washers and M6X80 bolts to attach headboard to bed frame Adapter

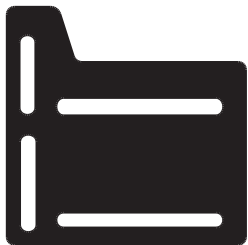

### STANDARD MODIFICATION PLATE

#### Parts List:

2 Adapter	4 M6x35 Bolts
8 Lock Nuts	4 M6x80 Bolts
8 Washers	

Figure 1

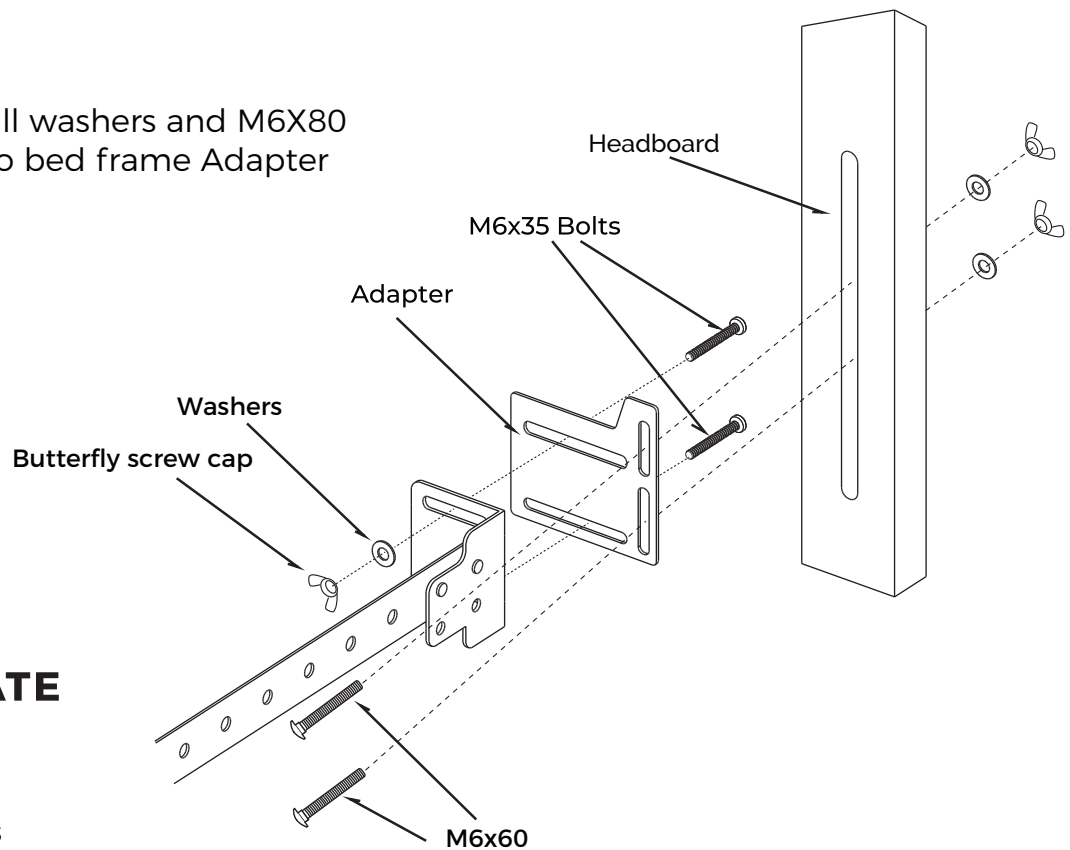

### PLEASE NOTE

Read all instructions before assembly. Save the assembly instructions for future use. Before each use or assembly, check for damaged hardware and missing parts. If replacement parts and instructions are needed, contact the manufacturer. Do not use replacement parts, and periodically check the tightness and location of fasteners and screws.

## The wall pendant

# ASSEMBLY INSTRUCTIONS

### Parts List:

Ex1 hex key

Fx2 Pendant

Gx8 Expansion screws set

### STEP 1

Electric drill drilling.

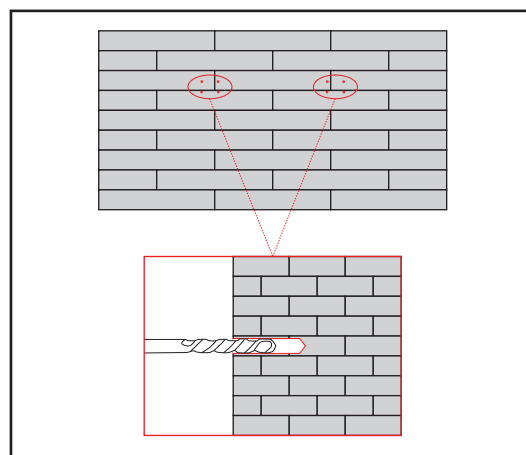

### STEP 2

Knock the Expansion screws plastic into the hold.

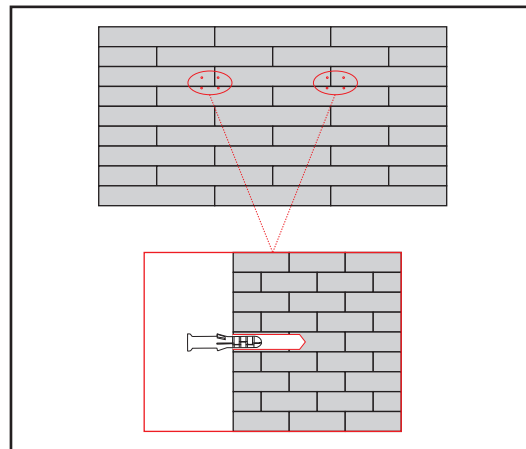

### STEP 3

Connect the pendent F with expansion screws G.

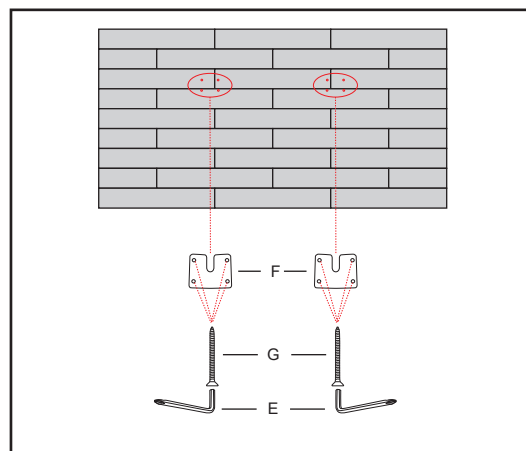

## The wall pendant

# ASSEMBLY INSTRUCTIONS

### STEP 4

Ensure that the screws are 100% tightened.

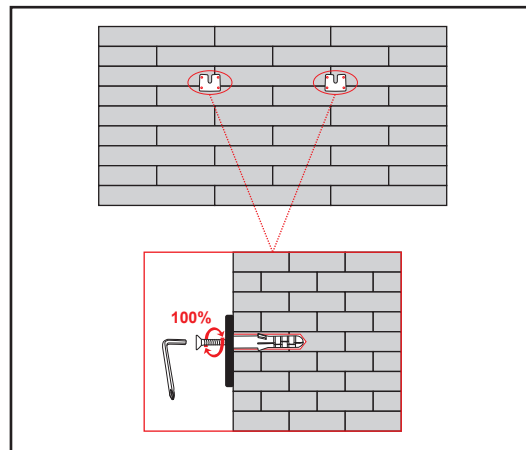

### STEP 5

Hang on the wall.

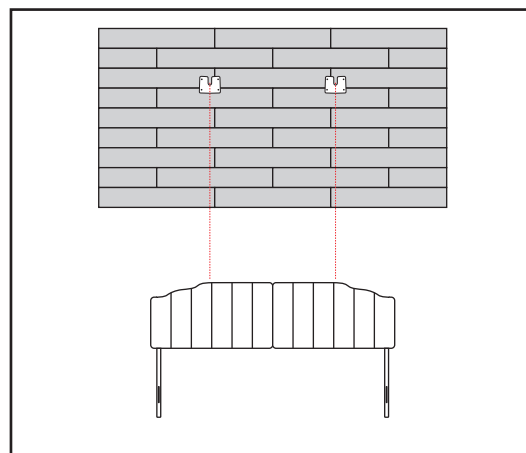

### STEP 6

Installation completed.

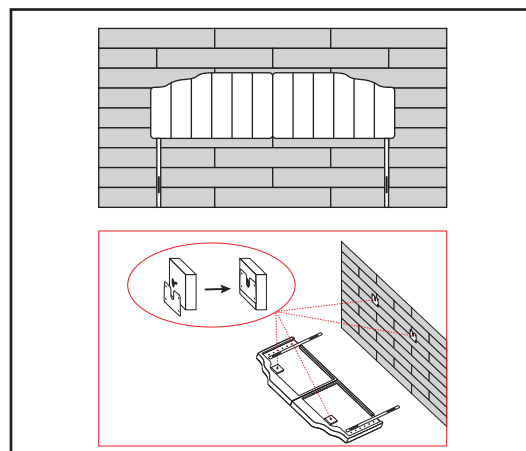

### PLEASE NOTE

Read all instructions before assembly. Save the assembly instructions for future use. Before each use or assembly, check for damaged hardware and missing parts. If replacement parts and instructions are needed, contact the manufacturer. Do not use replacement parts, and periodically check the tightness and location of fasteners and screws.