

Assembly | Asamblea | Assemblage

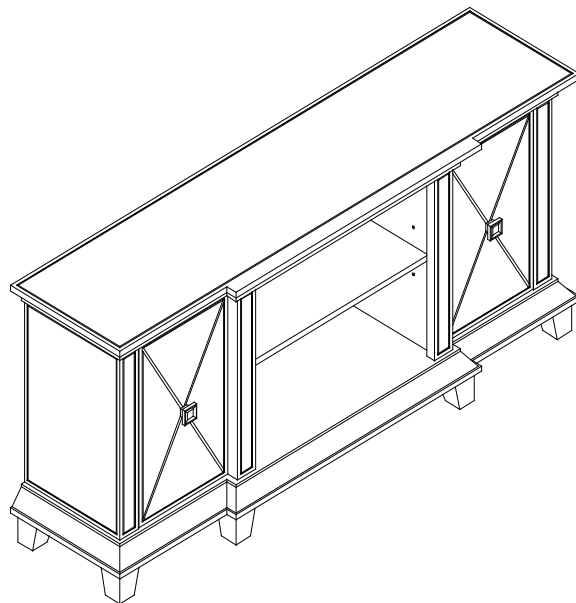
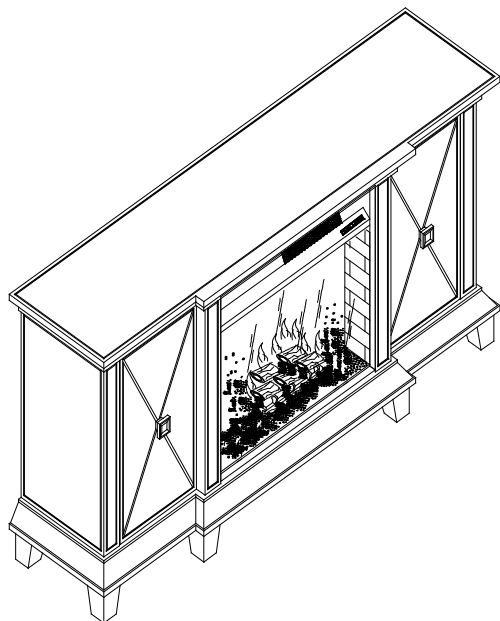

The following instructions show assembly steps for both fireplace and media stand models. Please follow assembly instructions to install firebox insert OR media shelf in accordance with your product purchase. Firebox insert only included with fireplace purchase (received in separate shipment).

Las siguientes instrucciones muestran los pasos de ensamblaje para los modelos de chimenea y soporte para medios. Siga las instrucciones de montaje para instalar el inserto de la chimenea O el estante multimedia según la compra del producto. El inserto para chimenea solo se incluye con compra de un chimenea (se recibe en un envío por separado).

Les instructions suivantes montrent les étapes d'assemblage pour les modèles de cheminée et de support multimédia. Veuillez suivre les instructions d'assemblage pour installer l'insert de foyer OU l'étagère multimédia conformément à l'achat de votre produit. L'insert de foyer n'est inclus qu'avec l'achat du foyer (reçu dans un envoi séparé).

Assembly | Asambla | Assemblage

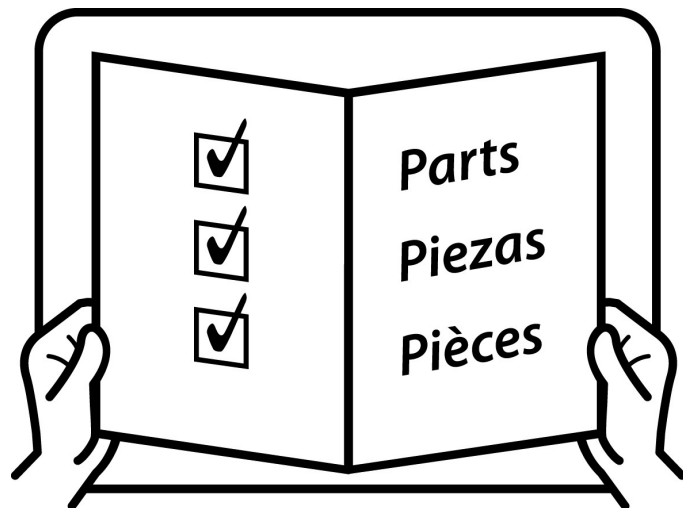
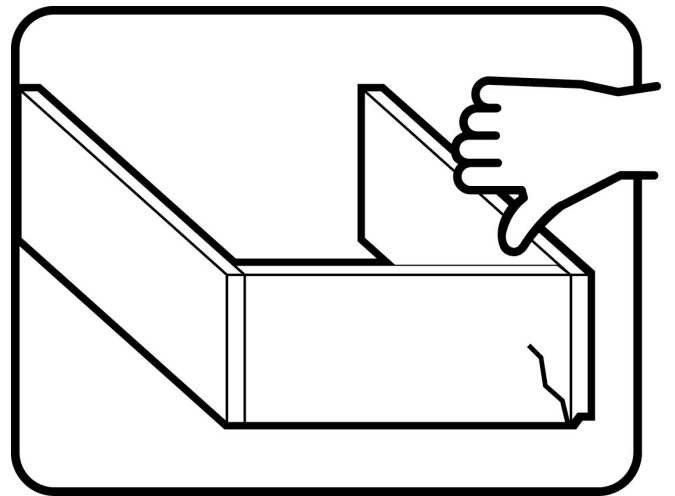
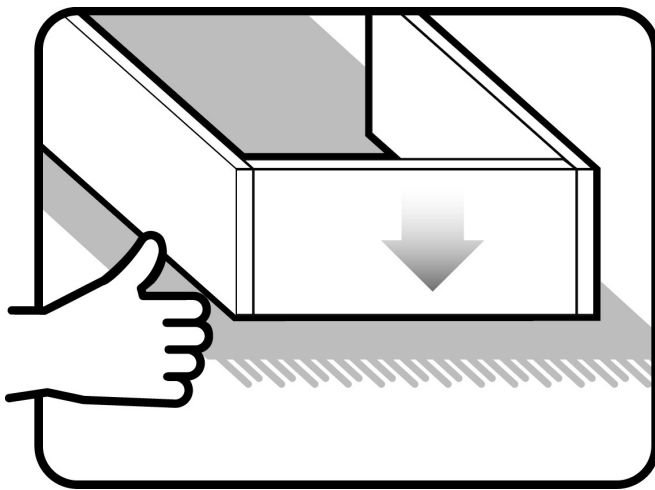
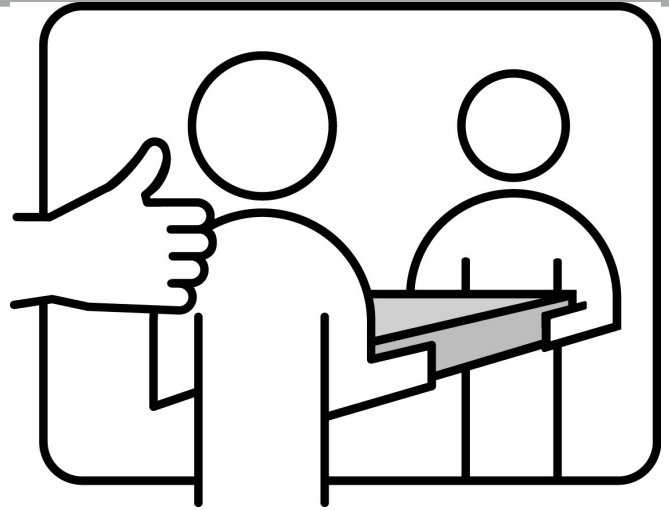
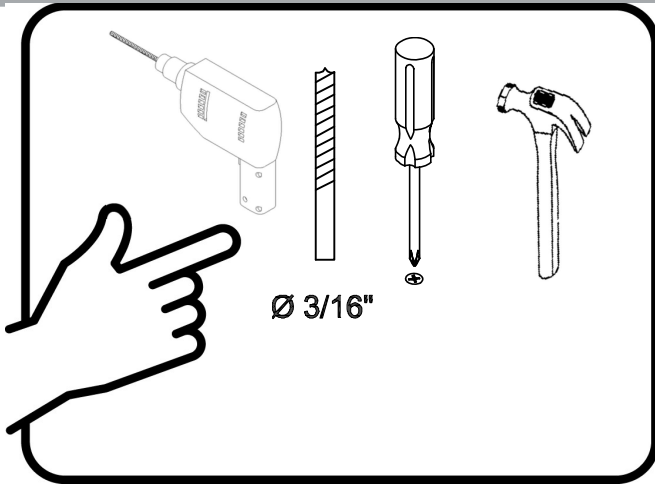

Assembly | Asamblea | Assemblage

Techniques | Técnicas | Techniques

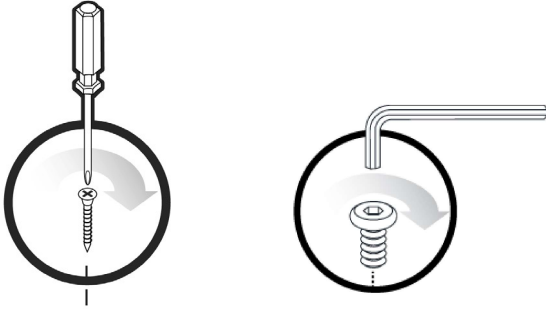

Care | Cuidado | Entretien



Safety | Seguridad | Sécurité





Note! | ¡Nota! | Remarque!

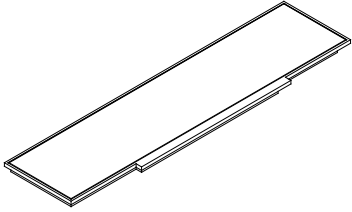
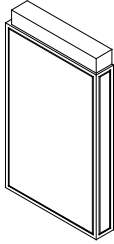
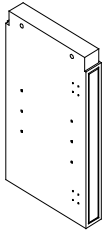
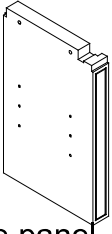
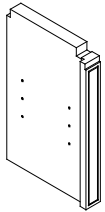
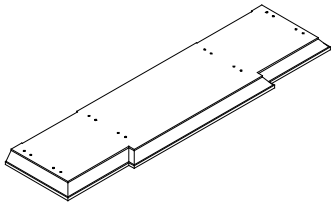
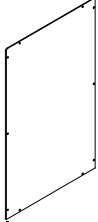
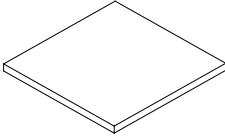
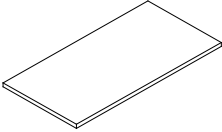
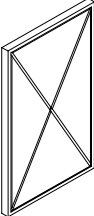
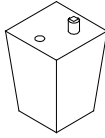
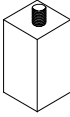
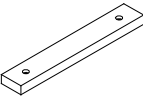

Assembly | Asamblea | Assemblage

<p>A x1</p>  <p>Top panel Panel superior Panneau du haut</p>	<p>B x1</p>  <p>Left frame Marco izquierdo Cadre gauche</p>	<p>C x1</p>  <p>Right frame Marco derecho Cadre droit</p>
<p>D x1</p>  <p>Left middle panel Panel central izquierdo Panneau central gauche</p>	<p>E x1</p>  <p>Right middle panel Panel central derecho Panneau central droit</p>	<p>F x1</p>  <p>Bottom frame Marco inferior Cadre inférieur</p>
<p>G x2</p>  <p>Back panel Panel posterior Panneau arrière</p>	<p>H x2</p>  <p>Side shelf Estante lateral Étagère latérale</p>	<p>I x1</p>  <p>Center shelf Estante central Étagère centrale</p>
<p>J x2</p>  <p>Door Puerta Porte</p>	<p>K x6</p>  <p>Leg Pierna Jambe</p>	<p>L x1</p>  <p>Center support leg Pata de apoyo central Jambe d'appui centrale</p>
<p>M x1</p>  <p>Wood holder Soporte de madera Support de bois</p>		

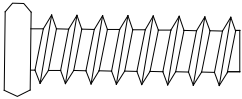
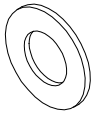
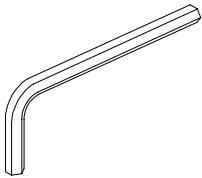
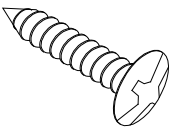
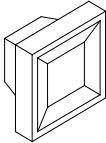
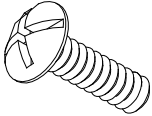
Assembly | Asamblea | Assemblage

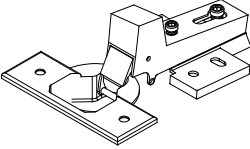
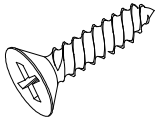
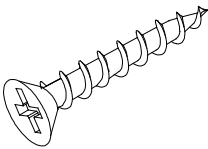
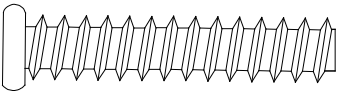
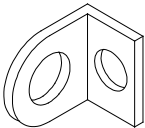
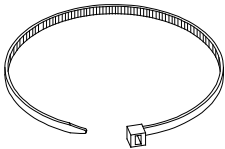
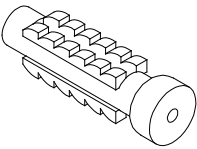
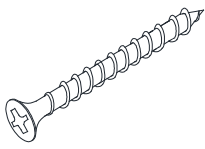
<p>1 x16</p>  <p>Bolt Tornillo Boulon</p> <p>ø1/4"*1-1/4"L</p>	<p>2 x16</p>  <p>Flat washer Arandela plana Rondelle plate</p> <p>ø1/4"</p>	<p>3 x1</p>  <p>Allen wrench Llave Allen Clé Allen</p> <p>ø1/4"</p>
<p>4 x20</p>  <p>Screw Tornillo Vis</p> <p>ø1/8"*1/2"L</p>	<p>5 x2</p>  <p>Knob Pomo Bouton</p>	<p>6 x4</p>  <p>Bolt Tornillo Boulon</p> <p>ø5/32" x3/4"L</p>
<p>7 x12</p>  <p>Shelf holder Titular de estante Porte-tablette</p>	<p>8 x4</p>  <p>Hinge Bisagra Charnière</p>	<p>9 x24</p>  <p>Screw Tornillo Vis</p> <p>ø3/8"*5/8"L</p>
<p>10 x2</p>  <p>Screw Tornillo Vis</p> <p>ø1/8"*3/4"L</p>	<p>11 x6</p>  <p>Bolt Tornillo Boulon</p> <p>ø1/4"*1-3/4"L</p>	<p>12 x4</p>  <p>Bracket Soporte Support</p>
<p>13 x2</p>  <p>Tie Corbata Attacher</p>	<p>14 x2</p>  <p>Anchor Ancla Ancre</p>	<p>15 x2</p>  <p>Screw ø4.0*1-1/4"L Tornillo Vis</p>

Assembly | Asamblea | Assemblage

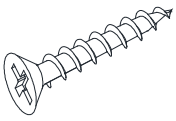
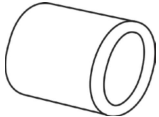
<p>16</p> <p>x2</p>  <p>Screw $\varnothing 4.0 \times 1/2'' L$ Tornillo Vis</p>	<p>17</p> <p>x4</p>  <p>Aluminum gasket Junta de aluminio Joint en aluminium</p>	
---	---	--

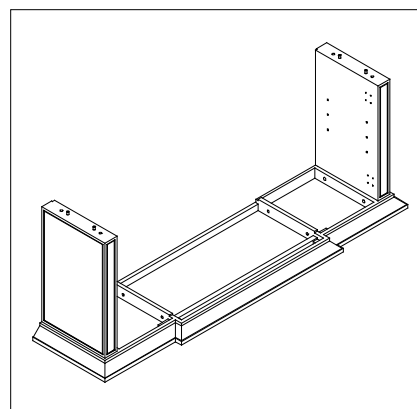
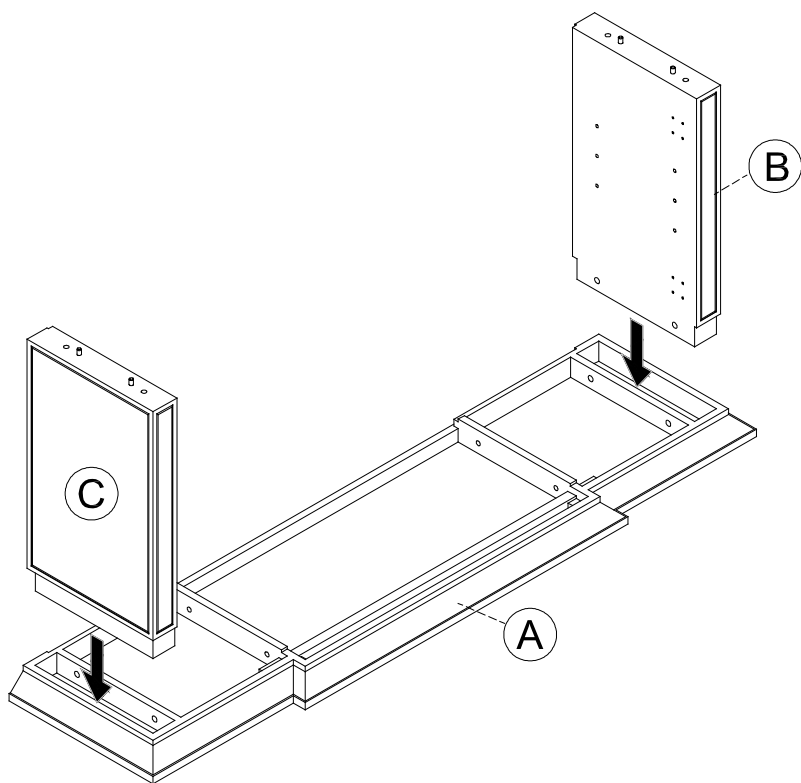

Assembly | Asambla | Assemblage

1

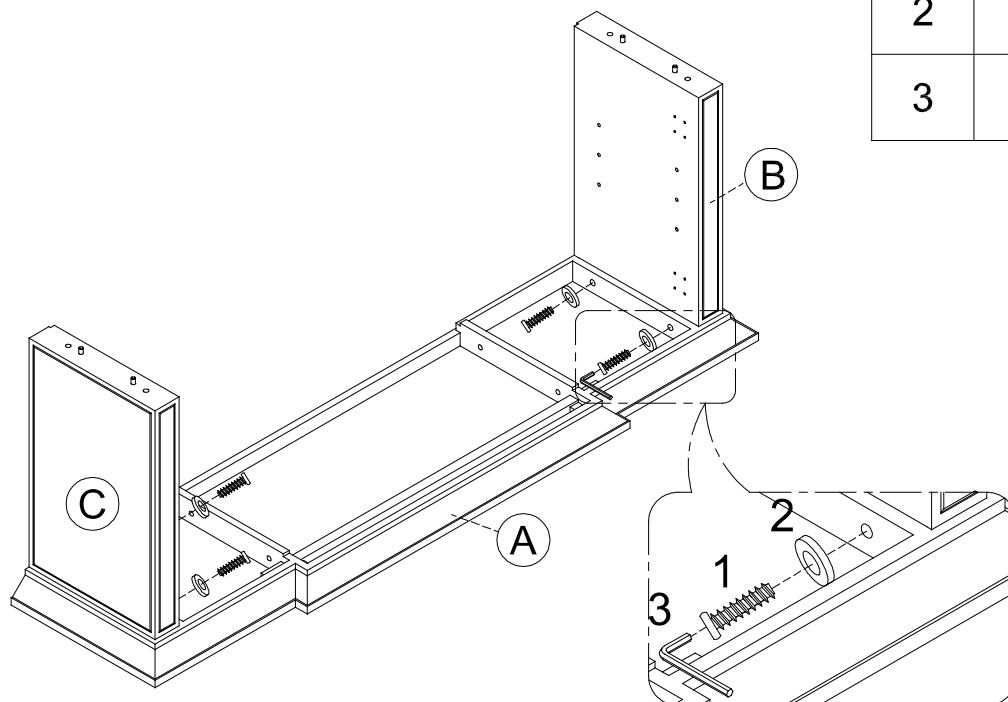

2

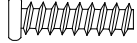

1		x 4
2		x 4
3		x 1

Assembly | Asambla | Assemblage

3

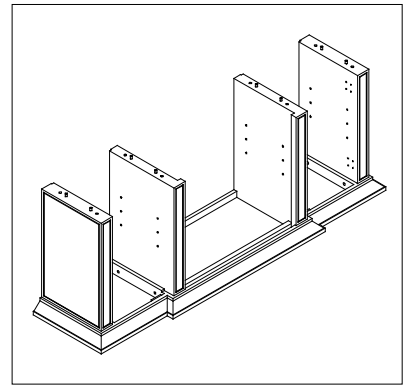
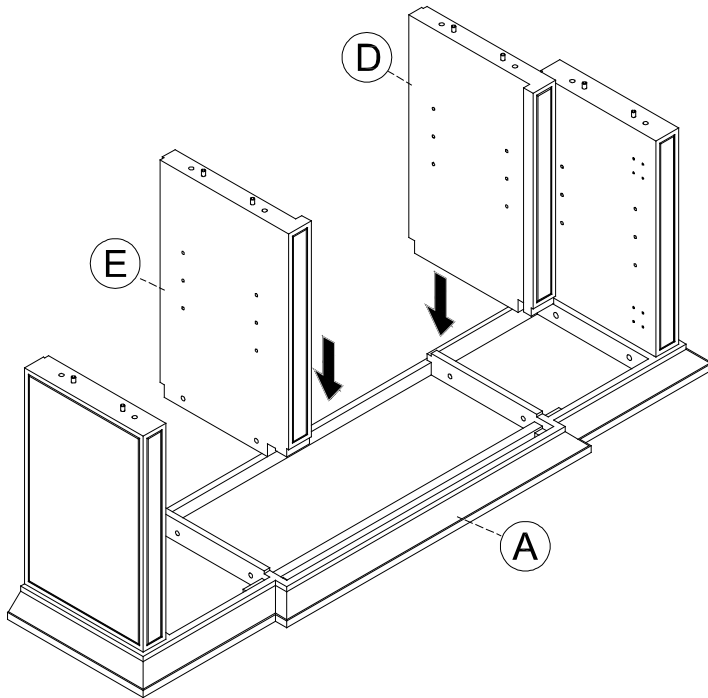

4

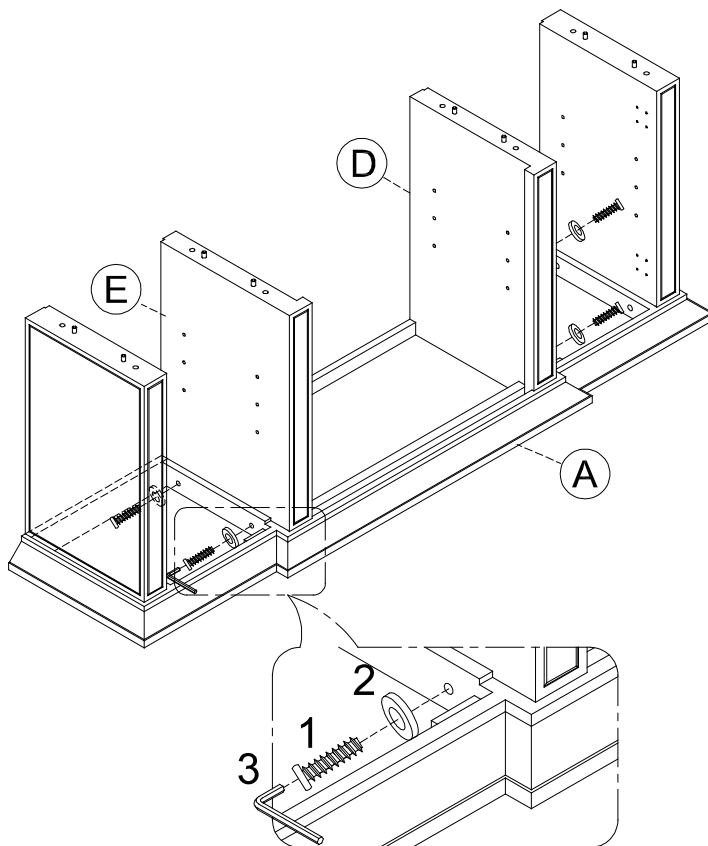



1		x 4
2		x 4

Assembly | Asambla | Assemblage

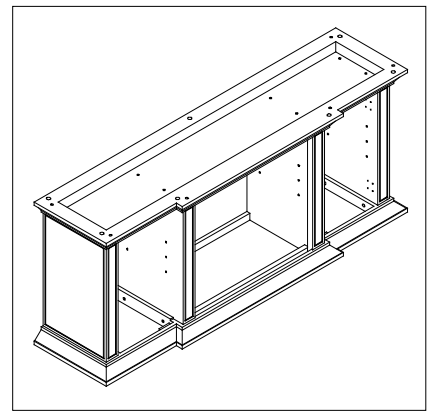
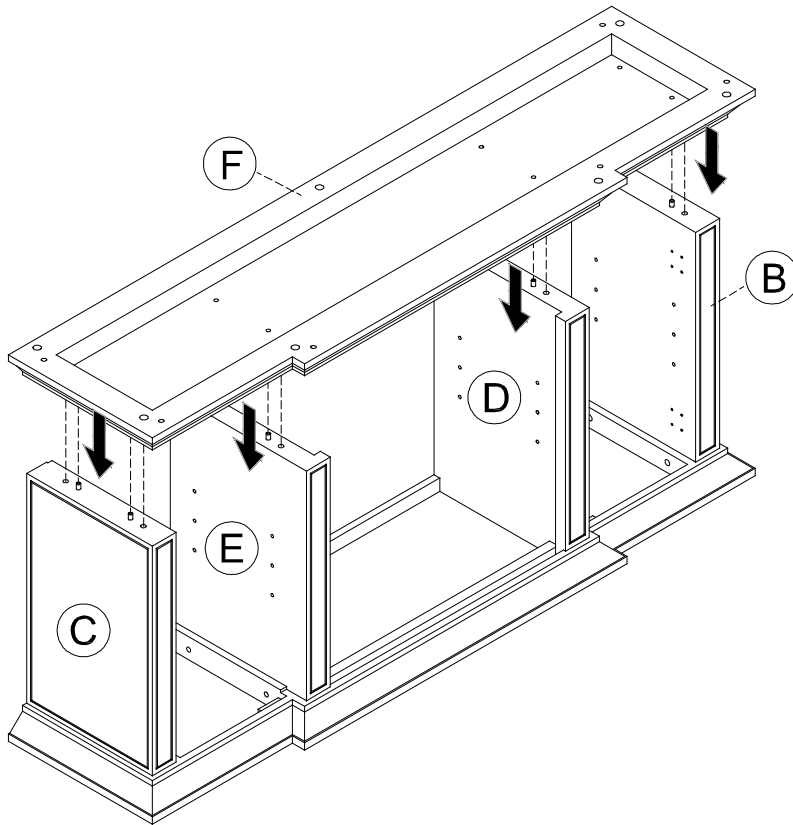
5



1		x 8
2		x 8

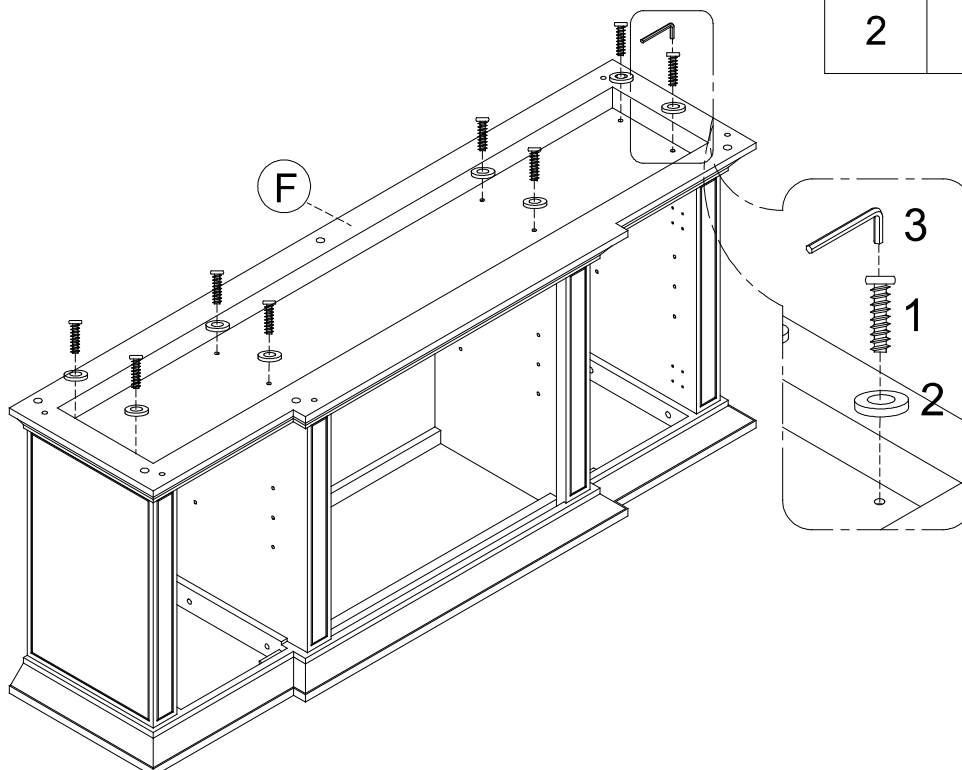

6

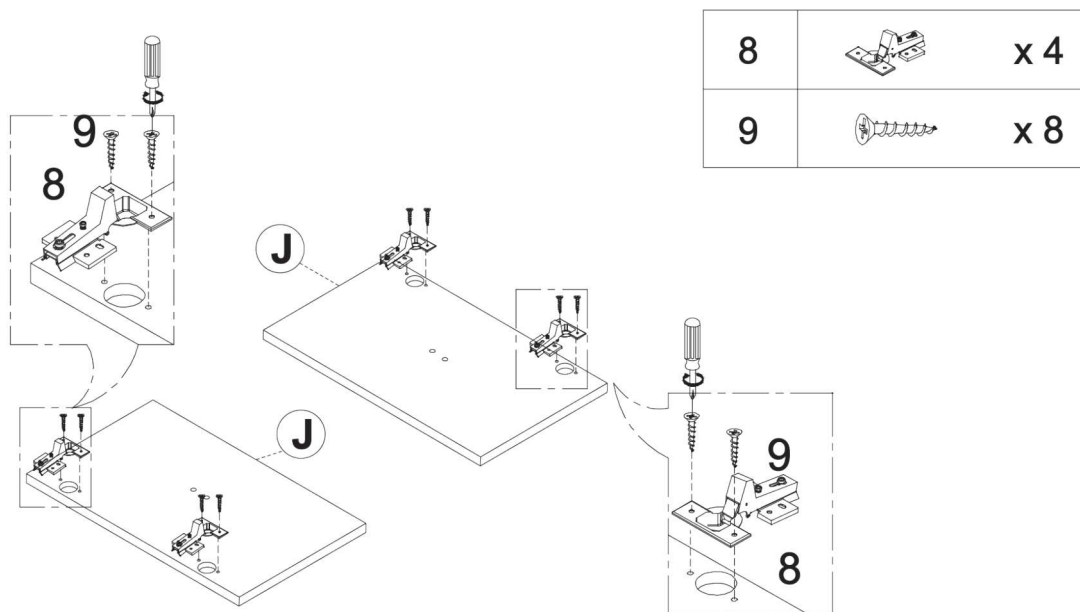

Assembly | Asamblea | Assemblage

9





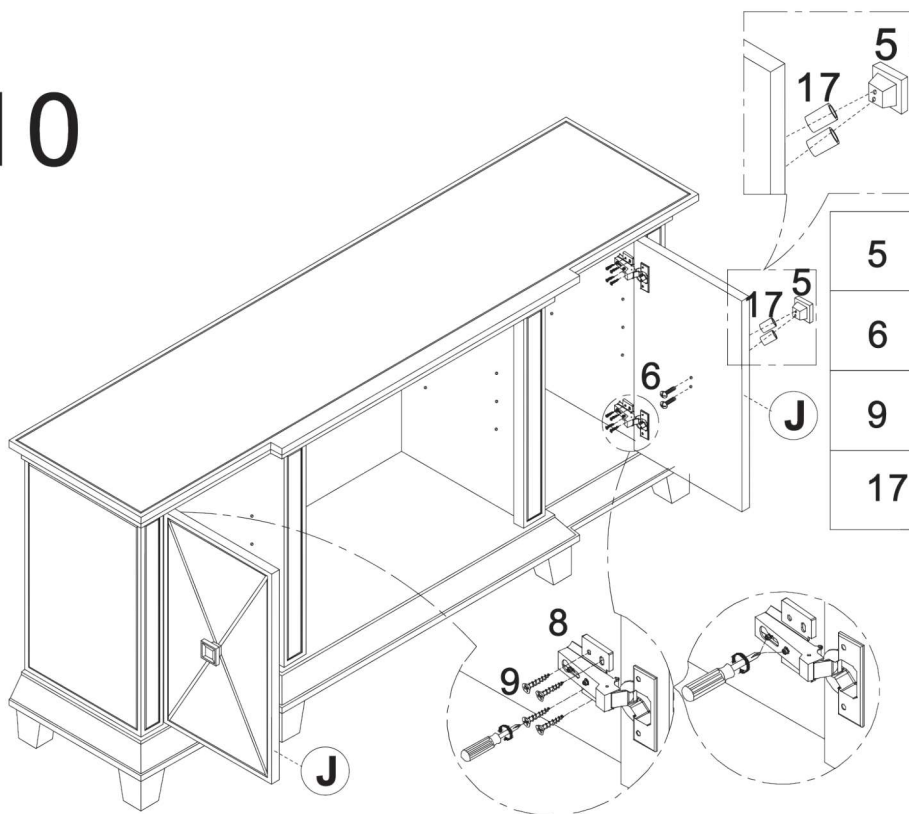

8		x 4
9		x 8

10



Do not overtighten knobs.
 No apriete demasiado las perillas
 Ne serrez pas trop les boutons.

5		x 2
6		x 4
9		x 16
17		x 4

Adjusting the doors:
 To achieve uniform clearance around the doors, tighten or loosen the screws on the hinges as needed.

Ajustando las puertas:
 Para lograr un espacio uniforme alrededor de las puertas, apriete o afloje los tornillos de las bisagras según sea necesario.

Ajuster les portes:
 Pour obtenir un jeu uniforme autour des portes, serrez ou desserrez les vis sur les charnières si nécessaire.

Assembly | Asamblea | Assemblage

11

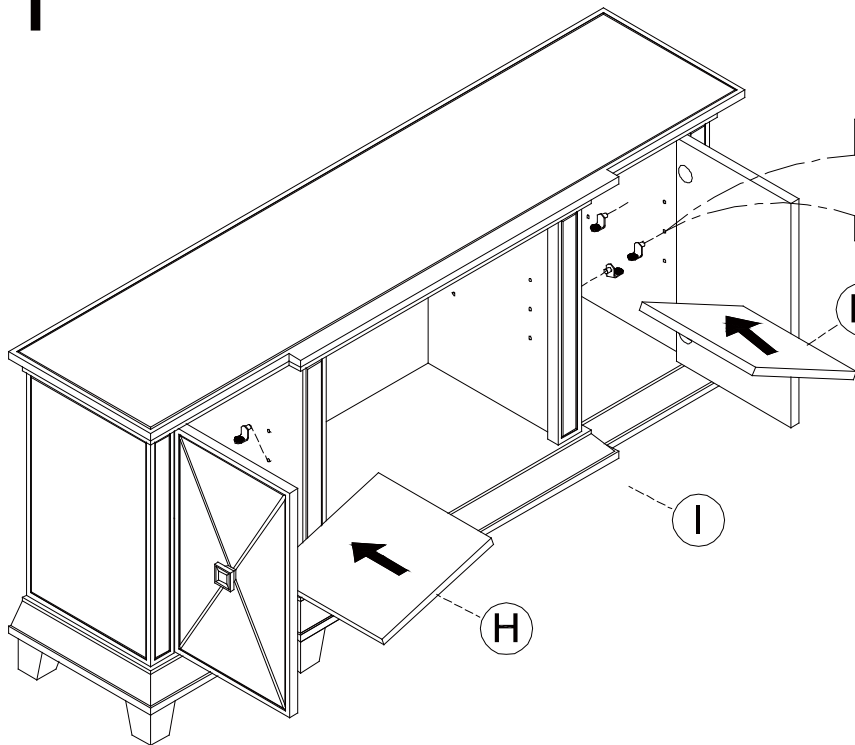

7		x 8
---	---	-----

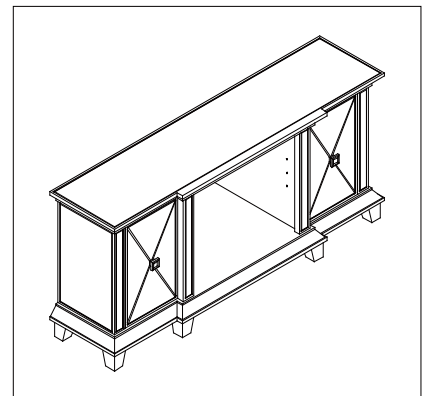
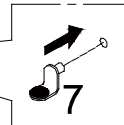

12

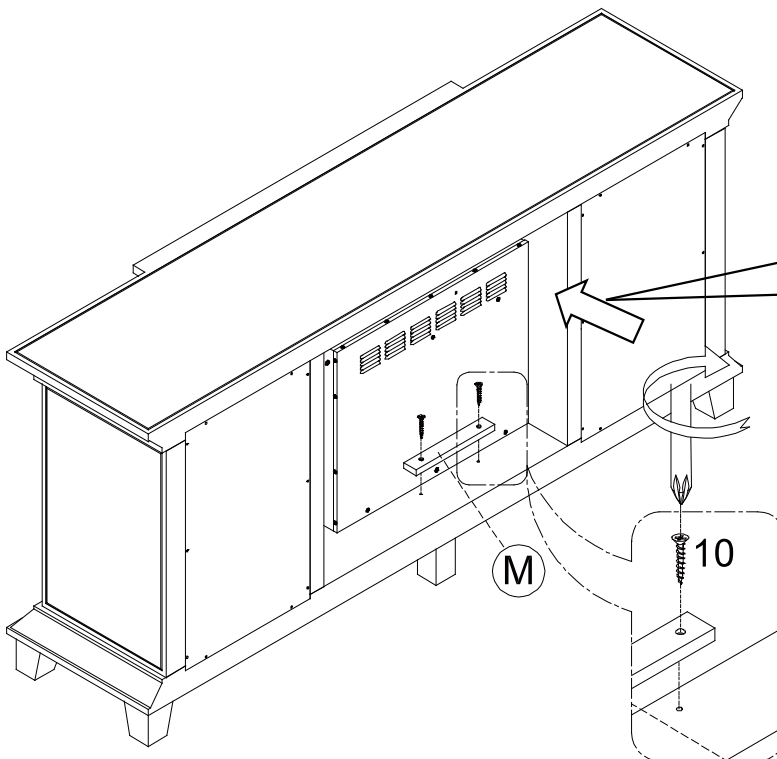

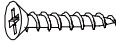
10		x 2
----	---	-----

**Firebox shipped in separate carton.
Firebox enviado en cartón separado.
Chambre de combustion expédiée dans
un carton séparé.**

Put the firebox gently into an appropriate position at the back of the cabinet and attach the wooden holder.

Coloque la caja de fuego suavemente en una posición adecuada en la parte posterior del gabinete y coloque el soporte de madera.

Placez doucement la chambre de combustion dans une position appropriée à l'arrière de l'armoire et fixez le support en bois.

Assembly | Asambla | Assemblage

13

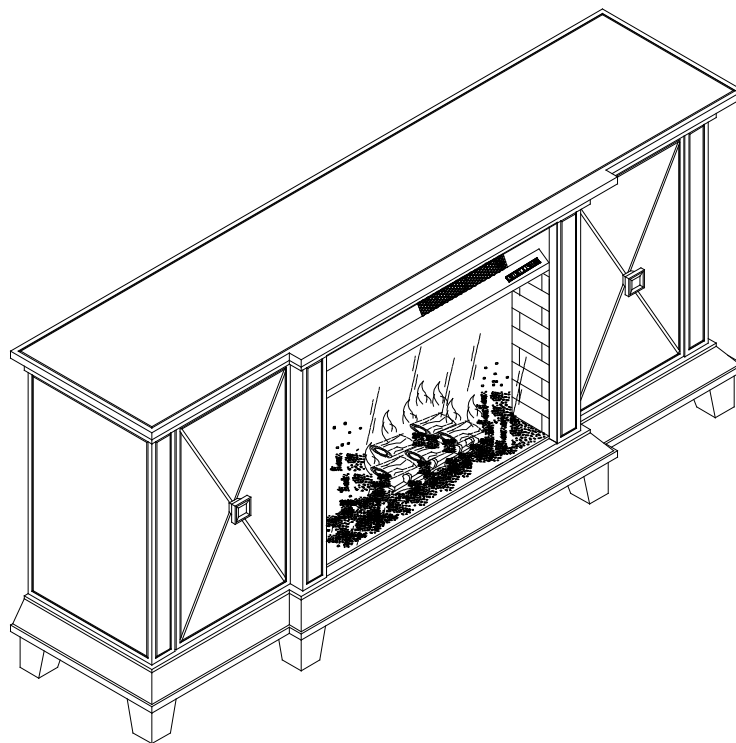

14

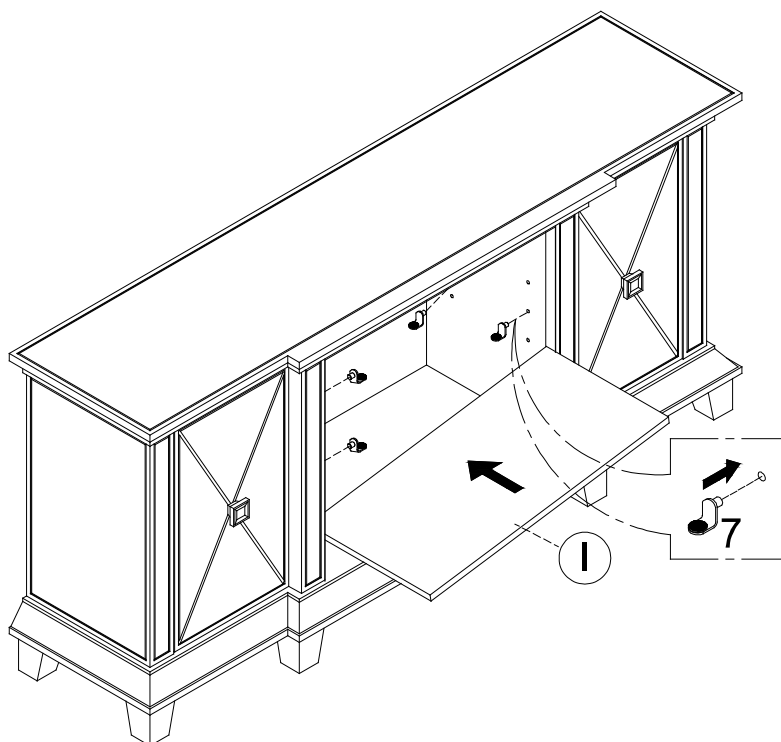

7		x 4
---	---	-----

To use as a media stand instead of a fireplace, do not insert firebox; instead insert shelf holders and shelf panel.



Para usarlo como soporte de medios en lugar de una chimenea, no inserte la caja de fuego; en su lugar, inserte los soportes para estantes y el panel para estantes.

Pour utiliser un support multimédia au lieu d'un foyer, n'insérez pas de chambre de combustion; insérez plutôt les supports d'étagères et le panneau d'étagères.

Assembly | Asamblea | Assemblage

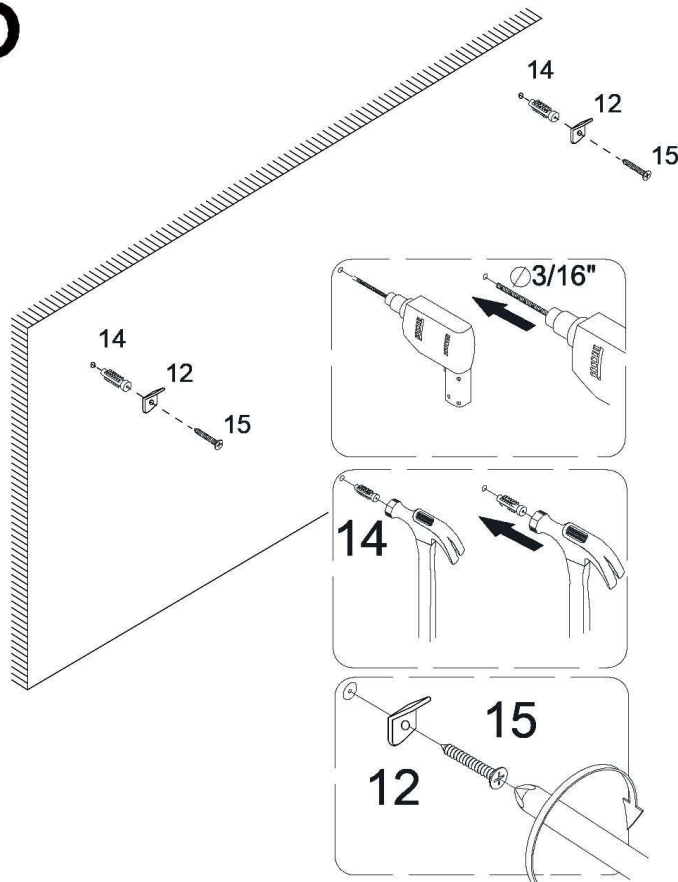
15



14		x2
12		x2
15		x2



Anti-tipping hardware must be used for this product to avoid tipping and injury.

Se debe usar hardware antivuelco para este producto para evitar que se vuelque y se lesione.

Une quincaillerie anti-basculement doit être utilisée pour ce produit afin d'éviter tout basculement et blessure.

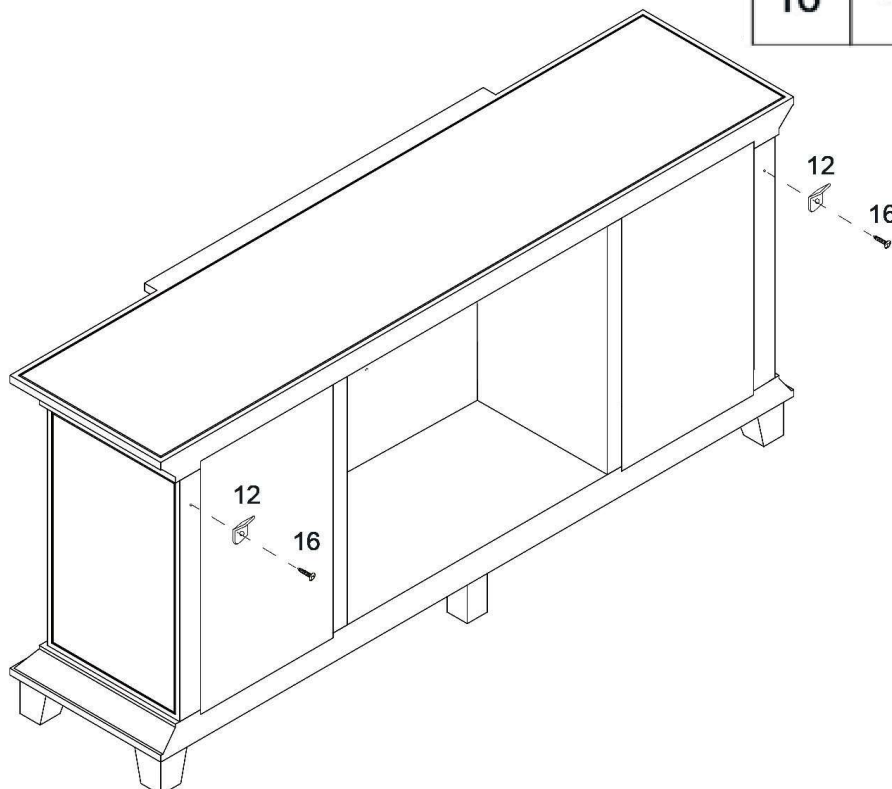
16



12		x2
16		x2

Assembly | Asambla | Assemblage

17

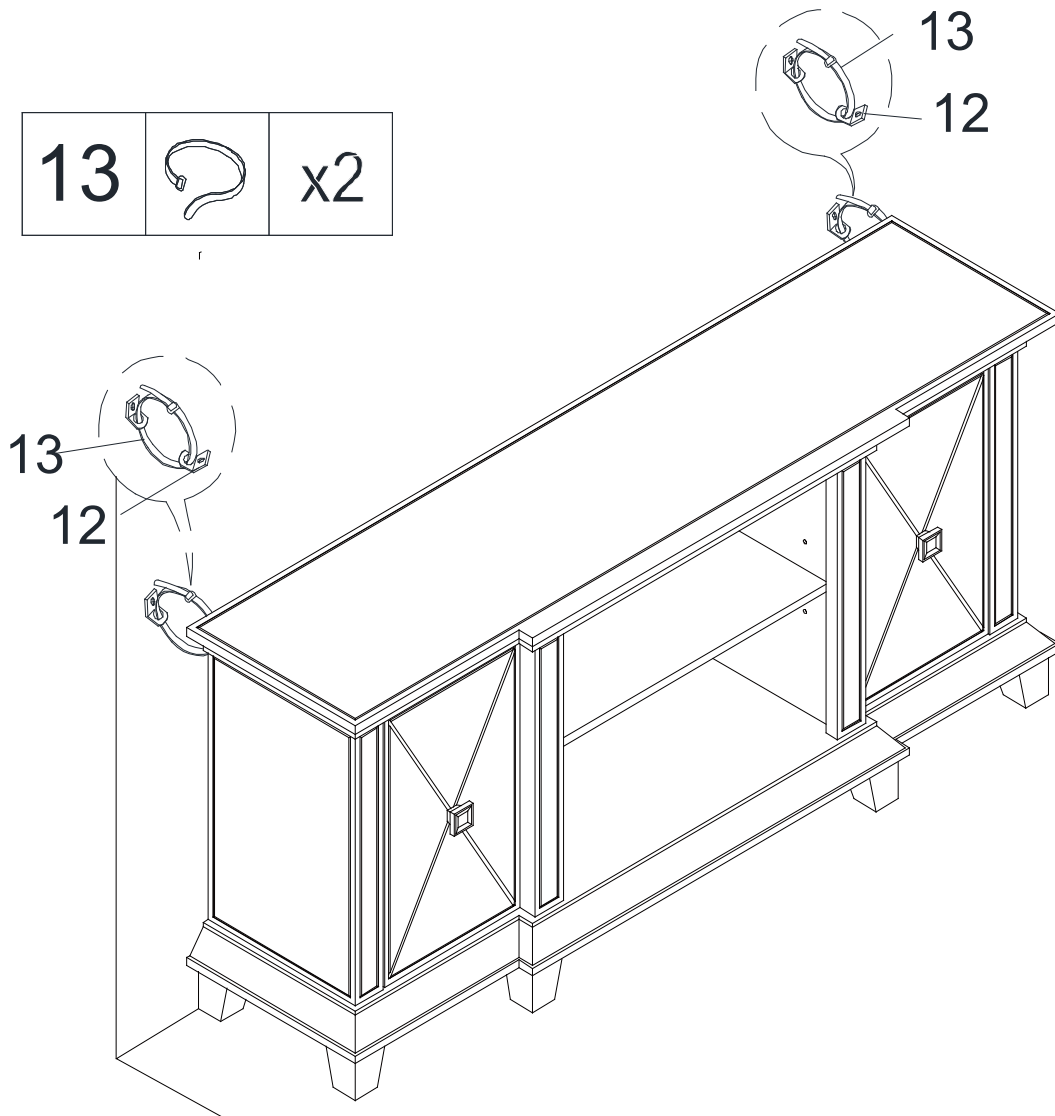
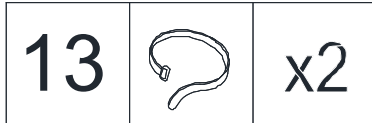

Assembly | Asambla | Assemblage

18

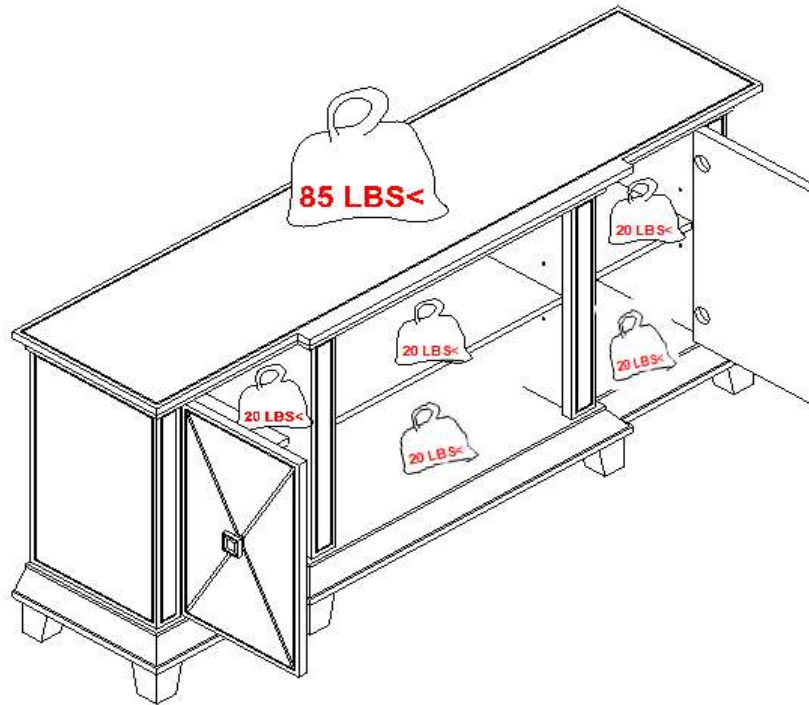

19

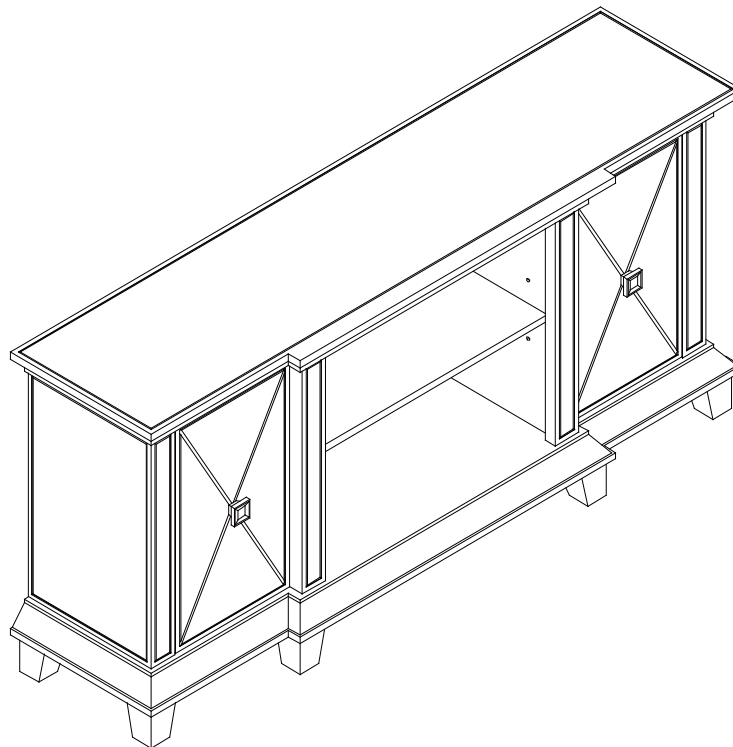

Assembly | Asamblea | Assemblage

Immediately examine this product carefully. Any request for missing or damaged part replacement must be received within 90 days of your receipt of the product. Requests for replacement parts, if available, will be honored within this time frame. Parts will not be available for items arriving fully assembled. We do not recommend modifying products and we are not responsible for any damages due to product modifications. If damages or missing parts are not reported within 90 days of receiving the product, we are under no obligation to provide parts or replacement merchandise.

Inmediatamente examine este producto con cuidado. Cualquier solicitud de reemplazo de piezas faltantes o dañadas debe recibirse dentro de los 90 días posteriores a la recepción del producto. Las solicitudes de repuestos, si están disponibles, serán atendidas dentro de este marco de tiempo. Las piezas no estarán disponibles para los artículos que lleguen completamente ensamblados. No recomendamos modificar los productos y no nos hacemos responsables de los daños debidos a las modificaciones del producto. Si no se informan daños o piezas faltantes dentro de los 90 días de haber recibido el producto, no estamos obligados a proporcionar piezas o productos de reemplazo.

Immédiatement examiner ce produit soigneusement. Toute demande de remplacement de pièce manquante ou endommagée doit être reçue dans les 90 jours suivant la réception de votre produit. Les demandes de pièces de rechange, si elles sont disponibles, seront honorées dans ce délai. Les pièces ne seront pas disponibles pour les articles arrivant complètement assemblés. Nous ne recommandons pas de modifier les produits et nous ne sommes pas responsables des dommages causés par des modifications du produit. Si les dommages ou les pièces manquantes ne sont pas signalés dans les 90 jours suivant la réception du produit, nous ne sommes pas tenus de fournir des pièces ou des produits de remplacement. En cas de problème avec le produit, veuillez ouvrir par la garantie ci-dessus.