

# MANUAL INSTRUCTION

## TV Stand

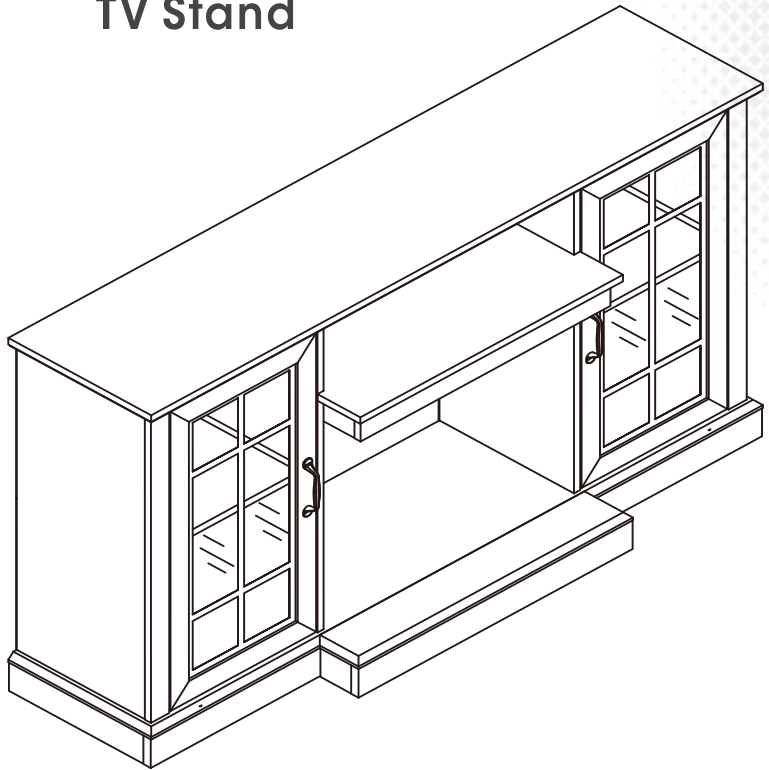

We offer a diverse range of products to meet the needs of customers.

## Indoor Furniture

---

We are a professional furniture provider with top-notch factories and outstanding designs, Our mission is to provide consumers with new lifestyles. By collecting consumer feedback, we constantly improve our products and create more choices for consumers. If you want to create your space, We are an ideal choice.

---

Always.

---



## WARNING

All the TV Stand have passed strict quality inspections before delivery. Read this manual carefully to ensure proper usage

---

Ensure that all parts and hardware are available before beginning assembly

## NOTICE

1. Children are not allowed to operate.
2. Faster installation is possible with power tools.
3. Do not pull the door vigorously to prevent the storage cabinet from tipping over.
4. Please attach the storage cabinet to the wall with an anti-tip device after installation is complete.
5. When using the storage cabinet for the first time, please keep it in a ventilated environment to allow the smell to fully evaporate.
6. When placing the partitions, please make sure the nails are firmly installed to prevent the partitions from falling off.
7. If any parts are missing, broken, damaged or worn, discontinue use of the product until repairs are made and/or factory replacement parts are installed.
8. Do not use this product in a manner inconsistent with the manufacturer's instructions, as this may void the product warranty.
9. If accessories are missing, please contact customer service for communication in time, we provide 7x24 hours customer care.
10. Do not use any attachments or accessories other than the original factory attachments and accessories.
11. Do not alter this equipment. Any alteration will create a safety hazard.

## WARNING

The product must be assembled by adult before use. Serious or fatal injury may occur from unexpected assembly or use.

1. During the assembly process, keep all parts away from babies or children.
2. Always securely fix this product to the wall. Make sure the wall area to be drilled is free from hidden electrical wires, water and gas pipes.
3. Use of tip-over restraints may only reduce, but not eliminate the risk of tip-over.
4. Unless specially designed to accommodate, do not set heavy objects on top of this product.
5. Place the heaviest items on the lowest shelf.
6. Never allow children to climb or bang on drawers, doors or shelves.

## AWARNING

- Do not allow children to climb on unit
- Serious or fatal crushing injuries can occur from furniture tip-over, To prevent this furniture from tipping
- Fixing devices for the wall are not included since different wall materials require different types of fixing devices. Use fixing devices suitable for the walls in your home. For advice on suitable fixing systems, contact your local specialized dealer.
- This unit contains small parts which can be swallowed by children and pets. Keep children and pets away during assembly. To avoid danger of suffocation, always keep plastic bags away from children and pets.

## BEFORE YOU START

- Separate and count all parts and hardware.
- Have the following tools: Flat head Screwdriver, #2 Philips Head Screwdriver.
- If using a power tools, please be ware to slow down and stop when screw is tight. Failure to do so may result in stripping the screw.
- Requires two people for assembly.

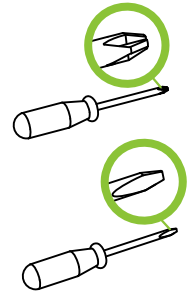

## CAMLOCK FASTENING SYSTEM

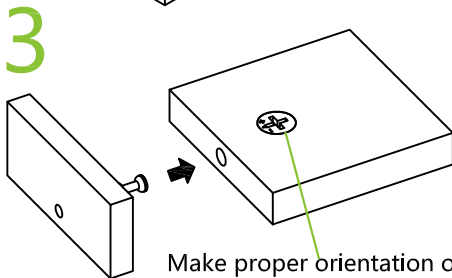
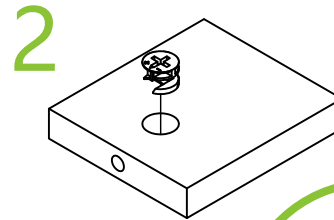
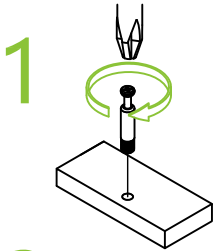

Make proper orientation of CAM LOCK when inserting CAM PIN

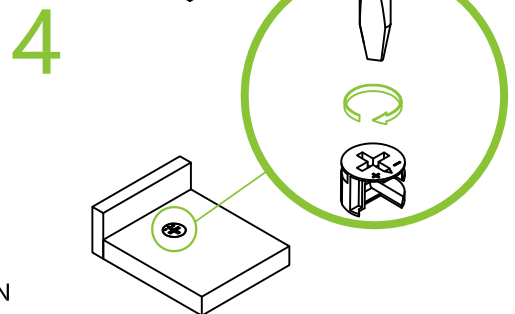

# TOOLS REQUIRED



Phillips Screwdriver



2 Persons Assembly



Up to 30 Minutes For Assembly

## PARTS

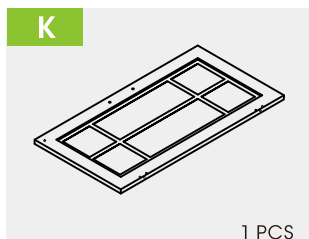
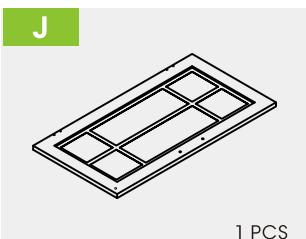
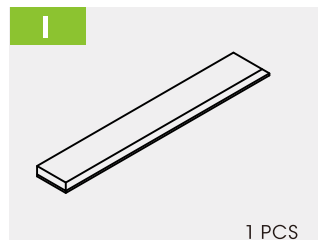
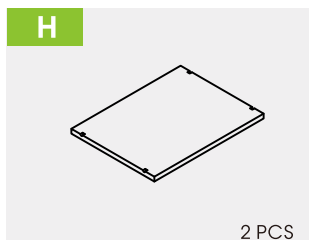
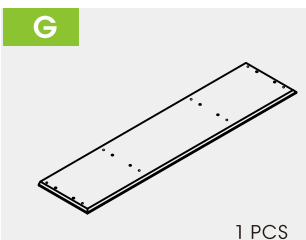
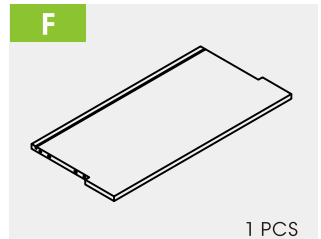
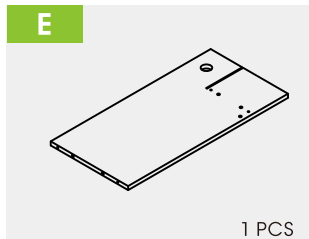
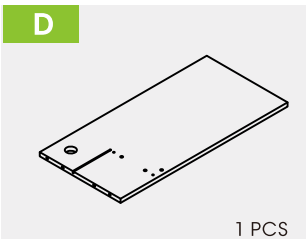
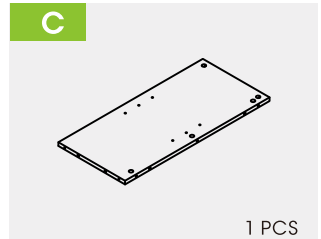
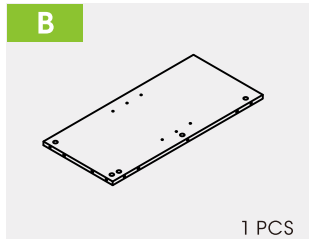
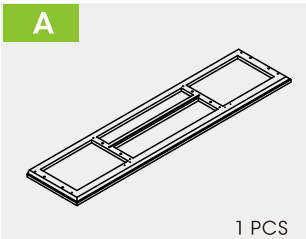

# TOOLS REQUIRED

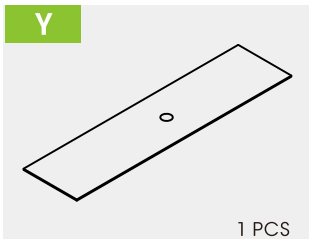
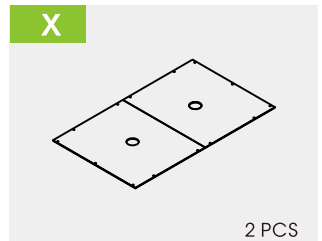
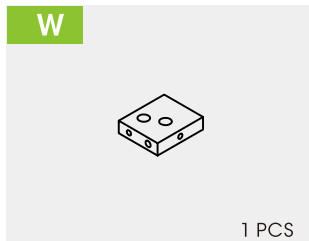
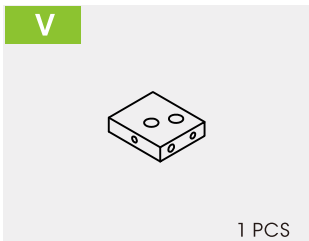
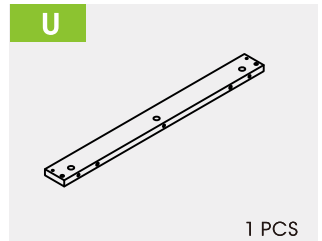
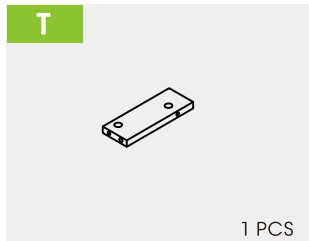
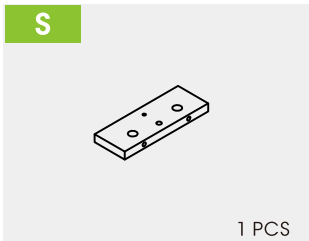
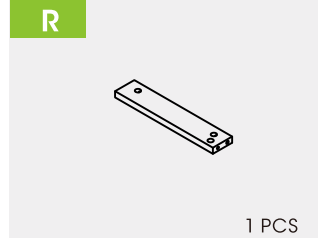
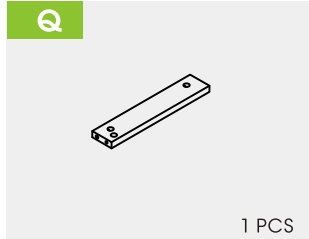
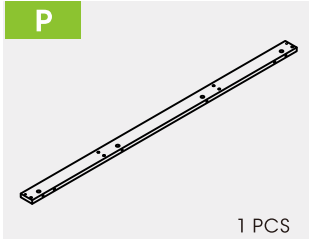
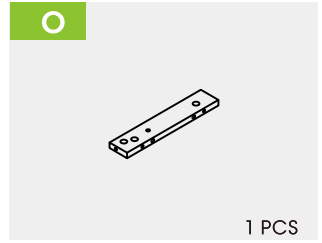
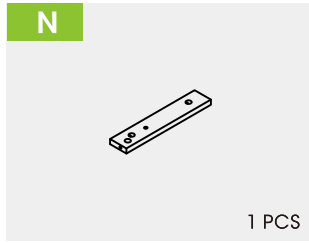
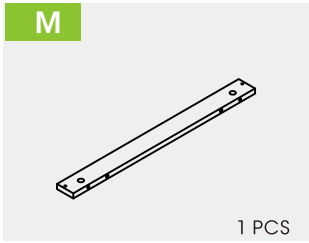

# HARDWARE

**1** CAM LOCK



47 PCS

**2** CAM PIN

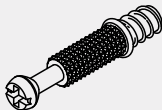

47 PCS

**3** WOOD DOWEL



43PCS

**4** SCREW  $\phi 6.3 \times 50$

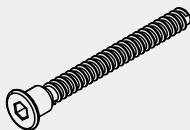

8 PCS

**5** SCREW M6X25

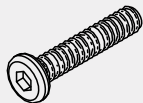

2 PCS

**6** SCREW  $\phi 3.5 \times 14$



30 PCS

**7** SCREW  $\phi 3 \times 14$



28 PCS

**8** SCREW  $\phi 4 \times 35$

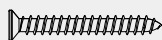

4 PCS

**9** SCREW M4X18



4 PCS

**10** ANGLE IRON



2 PCS

**11** HANDLE

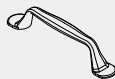

2 PCS

**12** MAGNET

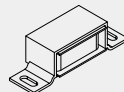

2 PCS

**13** METAL PLANT

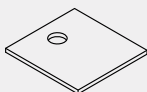

2 PCS

**14** HINGE



4 PCS

**15** HEX KEY 4X65MM

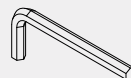

1 PCS

# HARDWARE

## 16 SHELT SUPPORT

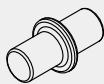

8 PCS

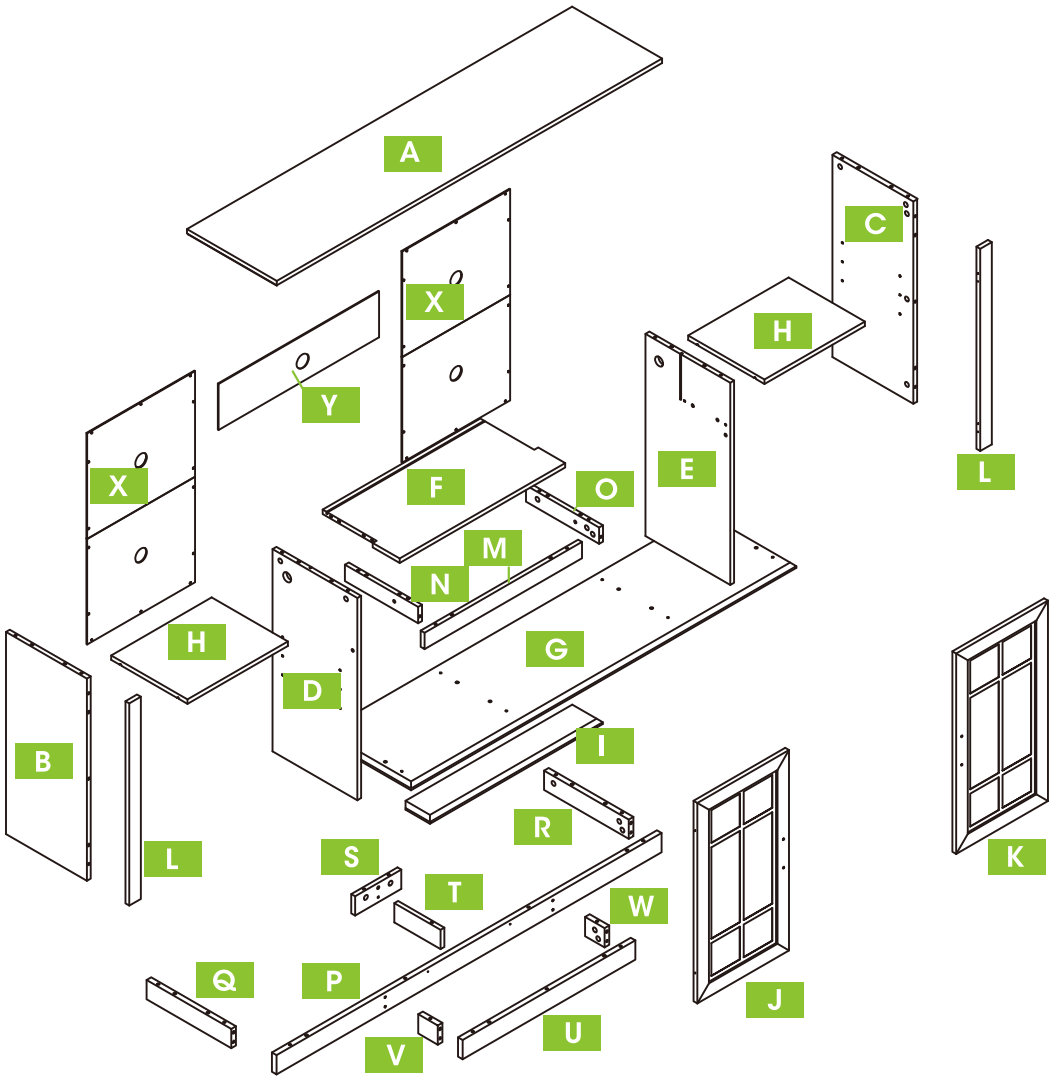

# PRODUCT ASSEMBLY

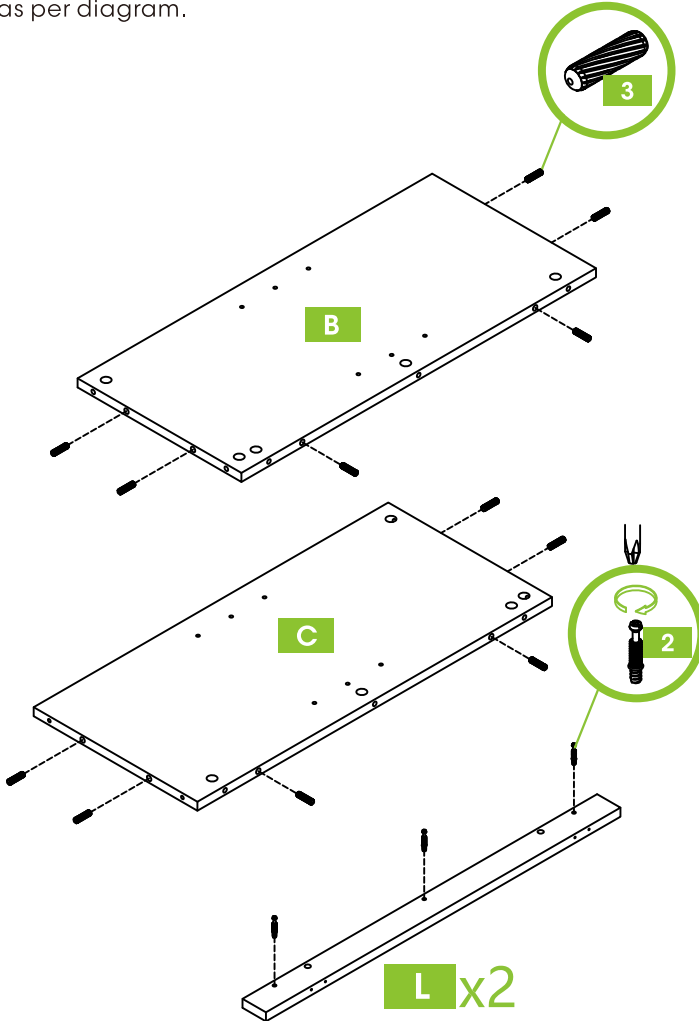

# PRODUCT ASSEMBLY Method A

**1** NOTE: Dear customer, if you purchase a TV stand & fireplace set, the package for the fireplace and the package for the TV stand will be delivered separately. If you purchase only the TV stand, the fireplace is not included. Install 12 wooden dowel " **3** " on the corresponding holes of the part B and part C as per diagram. Install 6 cam bolt " **2** " on the corresponding holes of the part L as per diagram.



PART	NO.	QTY.
	<b>2</b>	6
	<b>3</b>	12

# PRODUCT ASSEMBLY Method A

**2** NOTE: Use 6 cam lock " **1** " to connect part B&part C to part L and turn the screw clockwise;

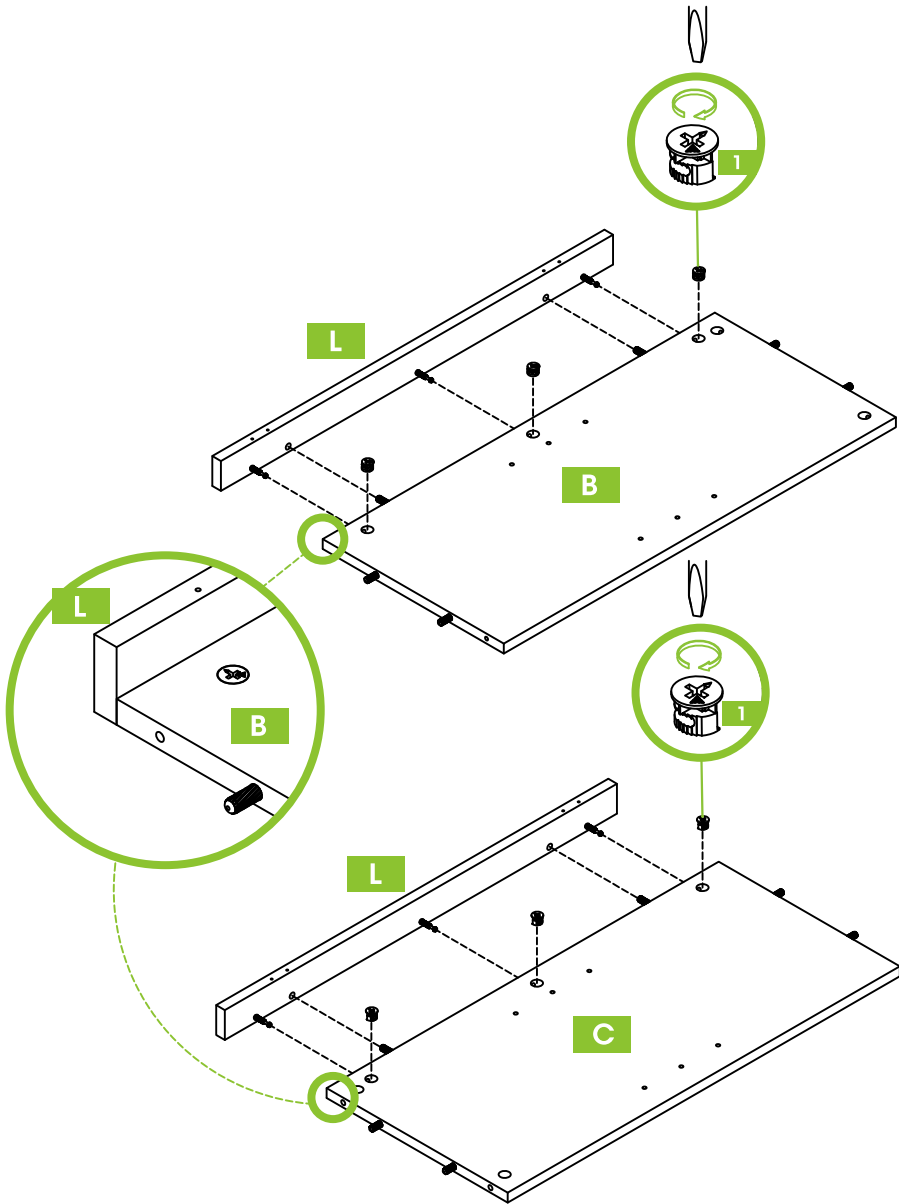

PART	NO.	QTY.
	1	6

# PRODUCT ASSEMBLY Method A

- 3** NOTE: Install 8 wooden dowel " **3** " and 4 cam bolt " **2** " on the corresponding holes of the part D and part E as per diagram.

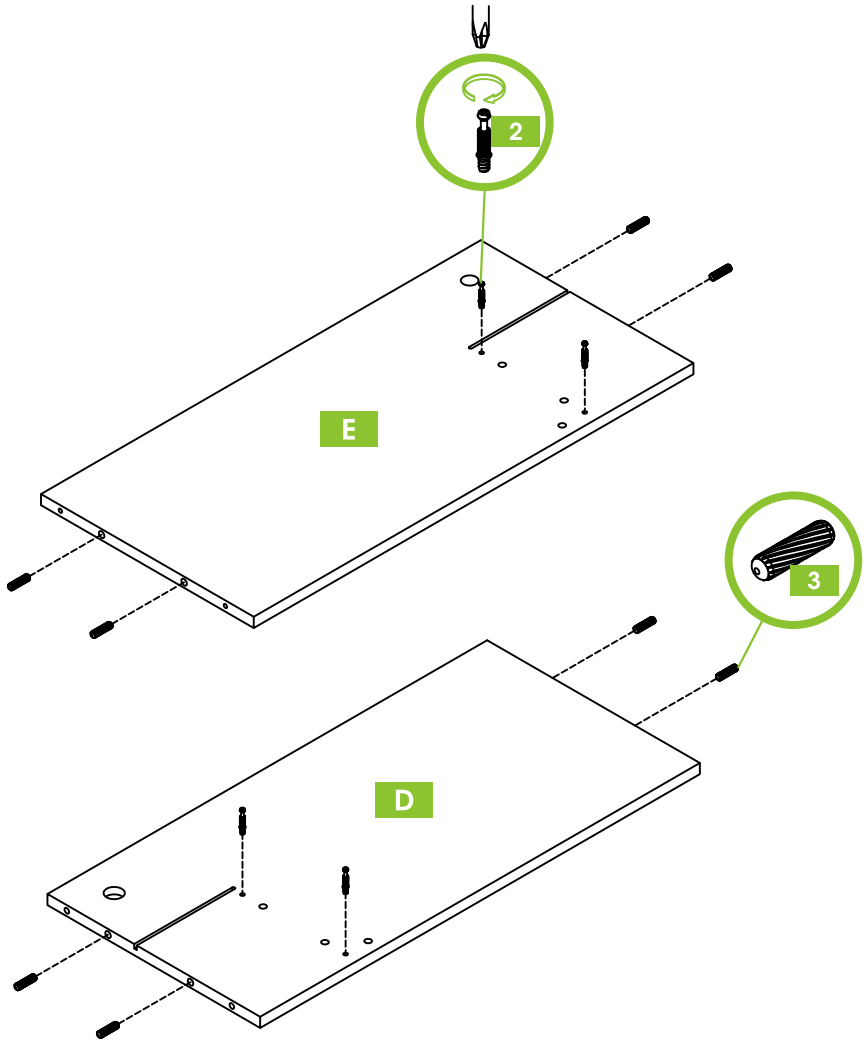

PART	NO.	QTY.
	<b>2</b>	4
	<b>3</b>	8

# PRODUCT ASSEMBLY Method A

- 4** NOTE: Install 10 wooden dowel "3" and 8 cam bolt "2" on the corresponding holes of the part F & part M & part N and part O as per diagram.

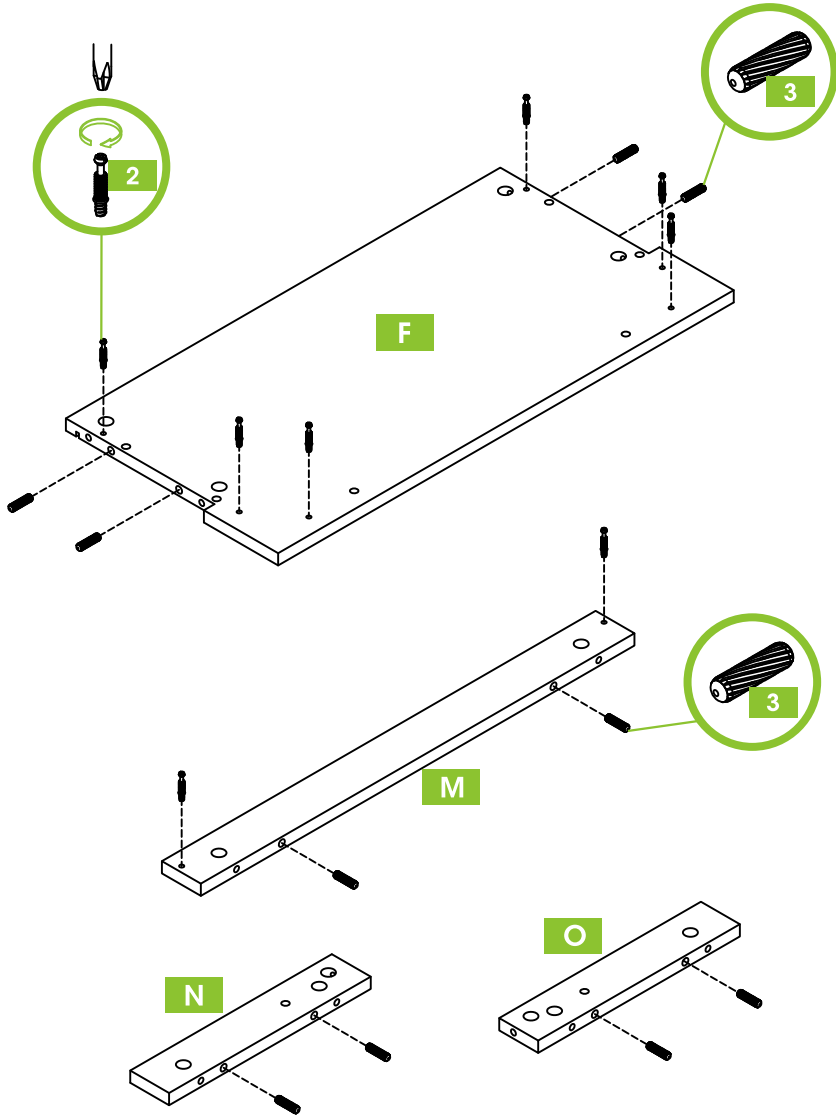

PART	NO.	QTY.
	2	8
	3	10

# PRODUCT ASSEMBLY Method A

**5** NOTE: Use 8 cam lock " **1** " to connect as per diagram and turn the screw clockwise;

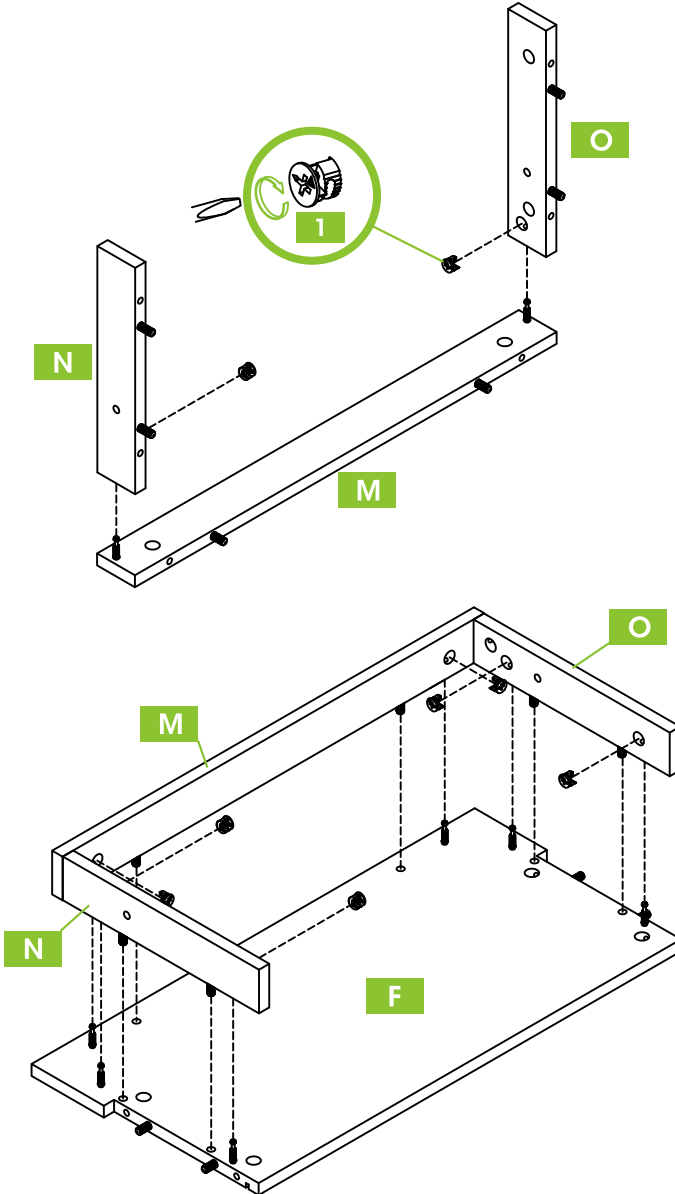



PART	NO.	QTY.
	1	8

# PRODUCT ASSEMBLY Method A

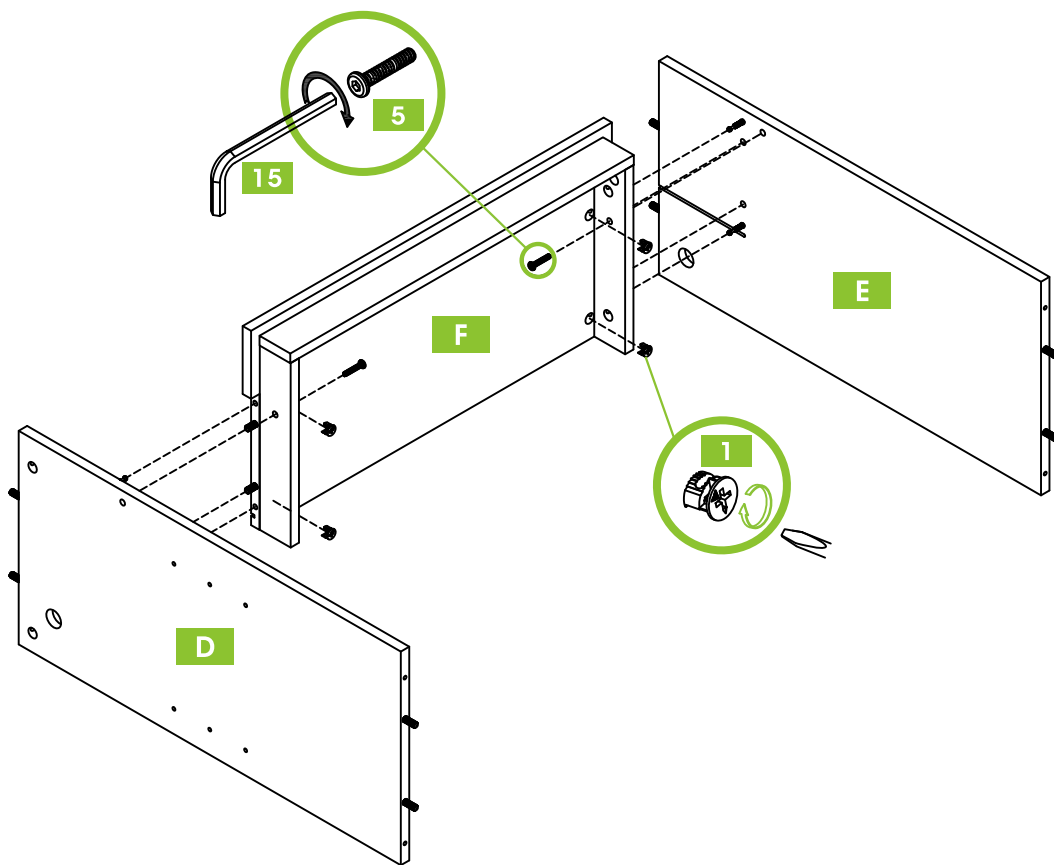
**6** NOTE: Install 4 cam lock " **1** " and 2 Machine screw " **5** " on the corresponding holes of the part F as per diagram. turn the screw clockwise;



PART	NO.	QTY.
	<b>5</b>	2
	<b>1</b>	4
	<b>15</b>	1

# PRODUCT ASSEMBLY Method A

**7** NOTE: Install 8 wooden dowel "**3**" and 13 cam bolt "**2**" on the corresponding holes of the part G & part P & part Q and part R as per diagram.

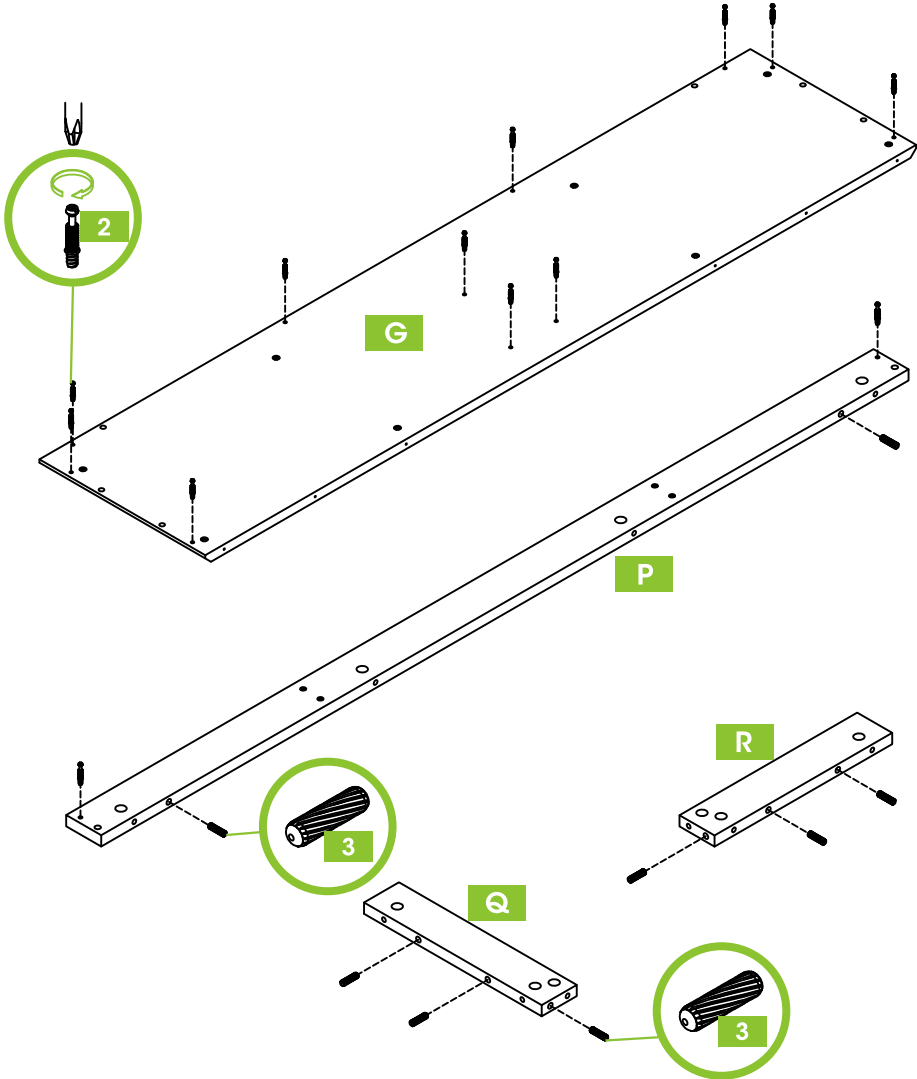



PART	NO.	QTY.
	2	13
	3	8

# PRODUCT ASSEMBLY Method A

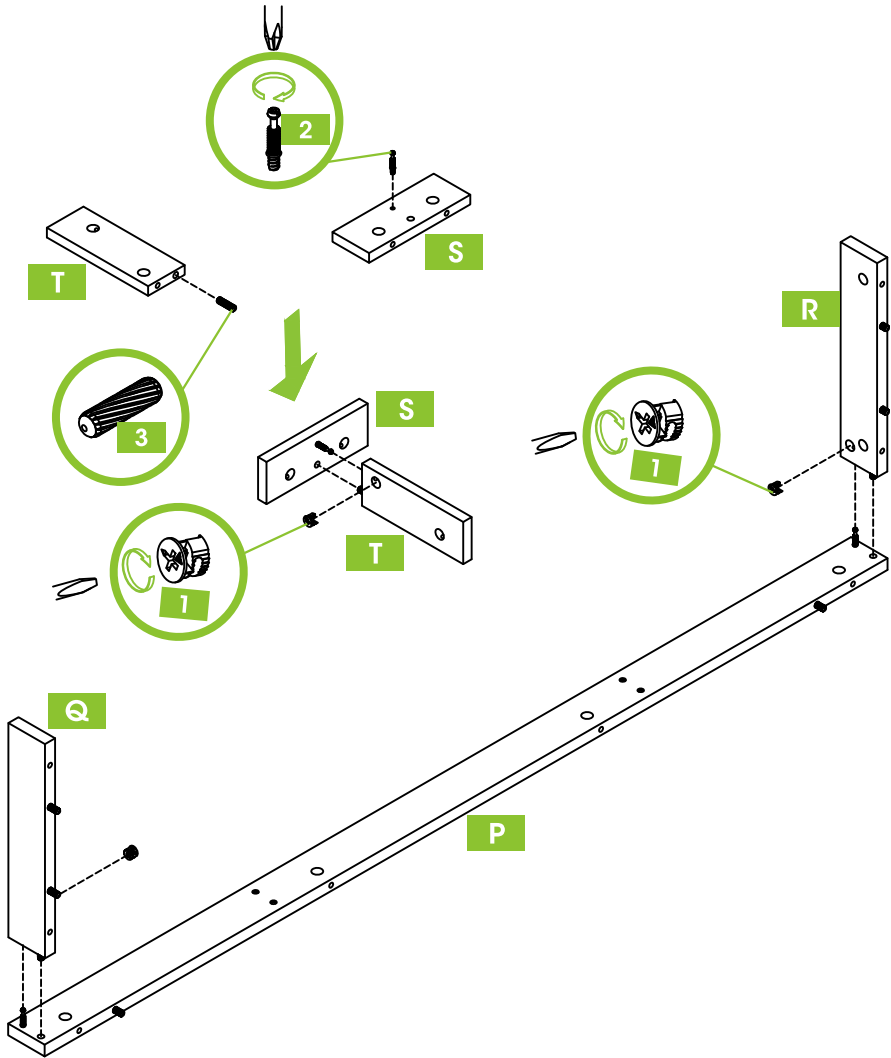
**8** NOTE: Install the following steps as per diagram.



PART	NO.	QTY.
	2	1
	3	1
	1	3

# PRODUCT ASSEMBLY Method A

**9** NOTE: Install the following steps as per diagram.

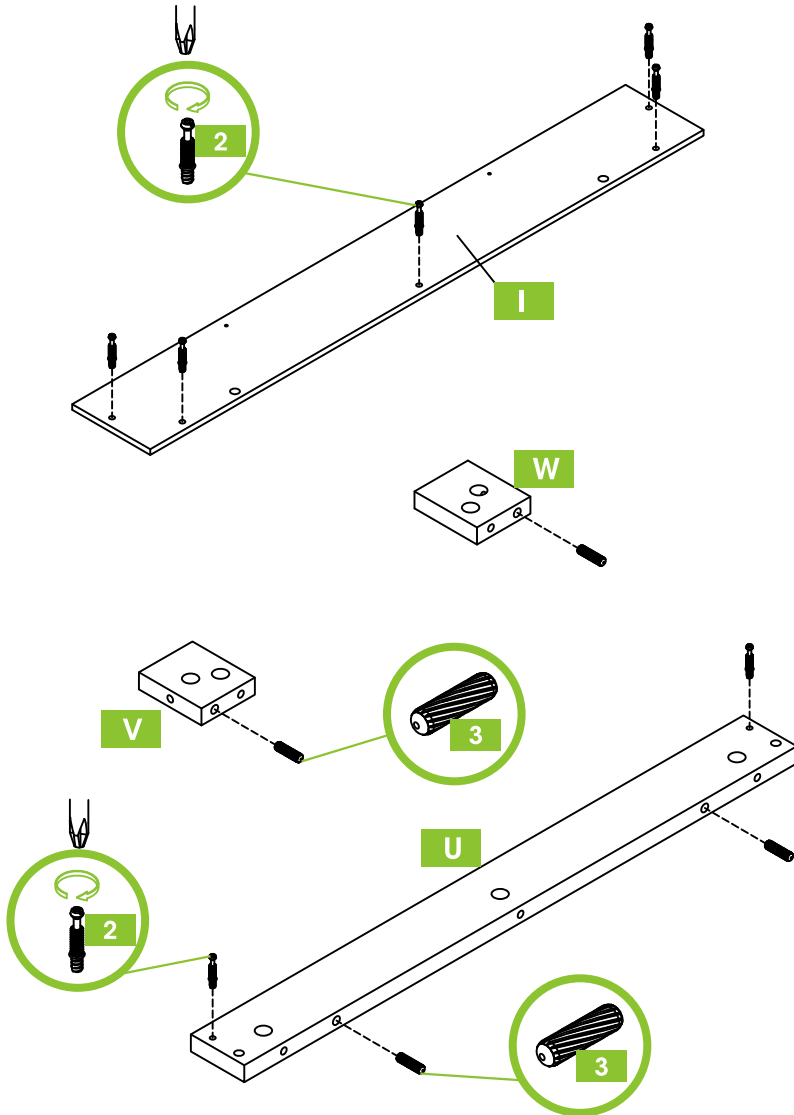

PART	NO.	QTY.
	2	7
	3	4

# PRODUCT ASSEMBLY

**10** NOTE: Install the following steps as per diagram.

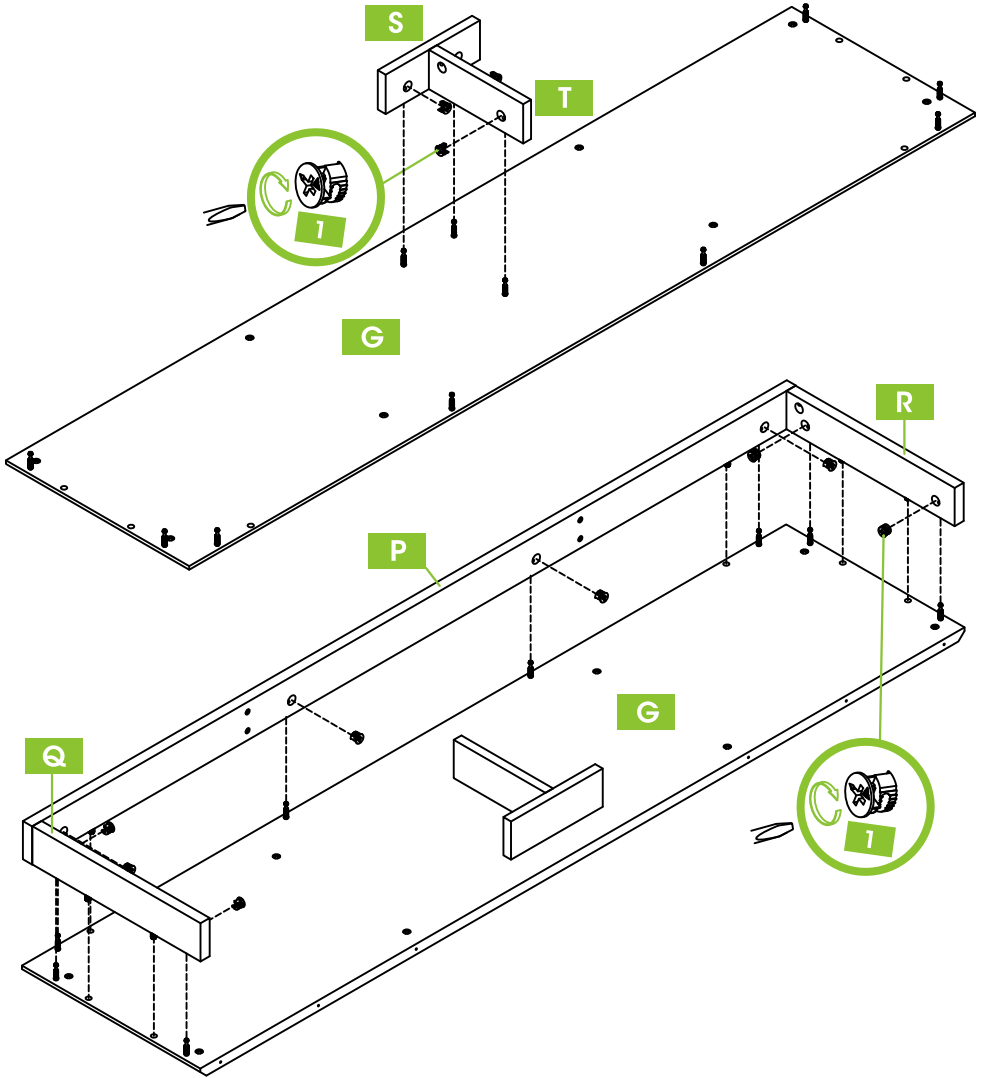

PART	NO.	QTY.
	1	11

# PRODUCT ASSEMBLY

**11** NOTE: Install the following steps as per diagram.

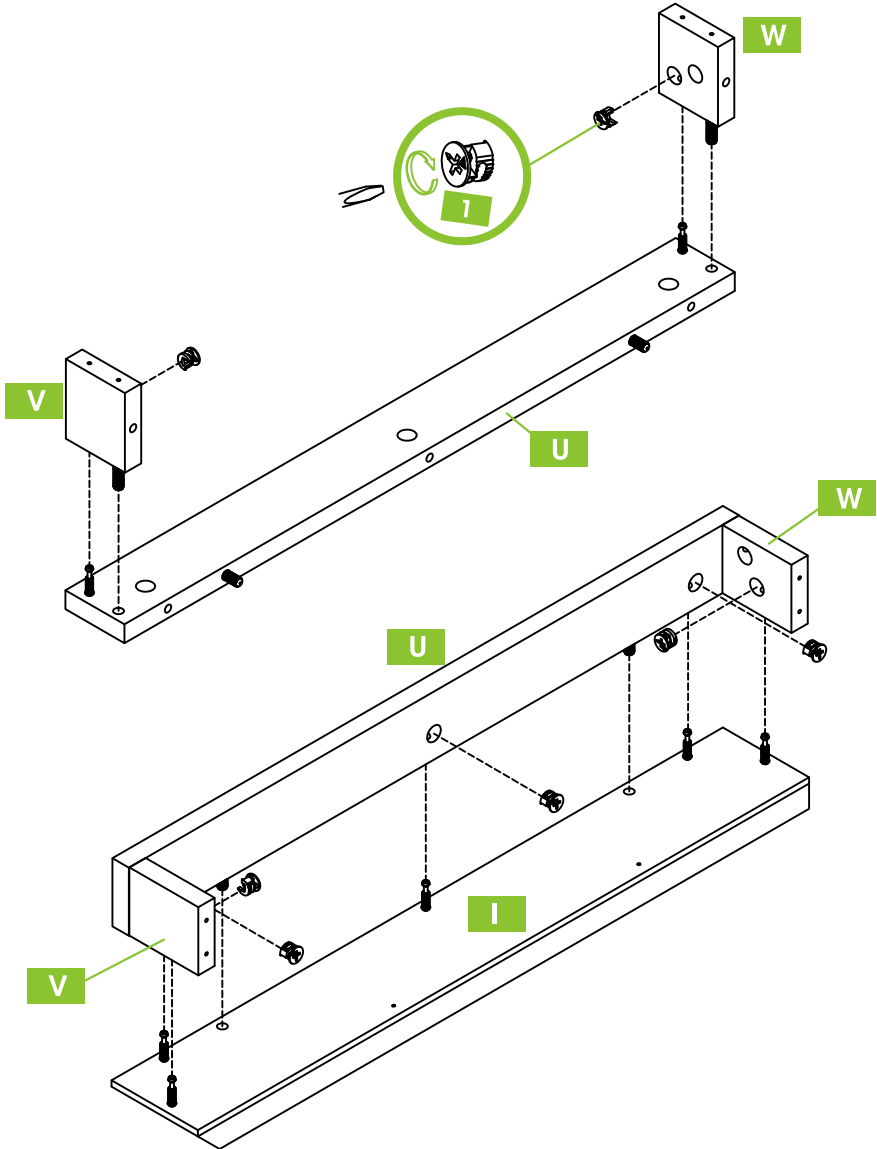



PART	NO.	QTY.
	1	7

# PRODUCT ASSEMBLY

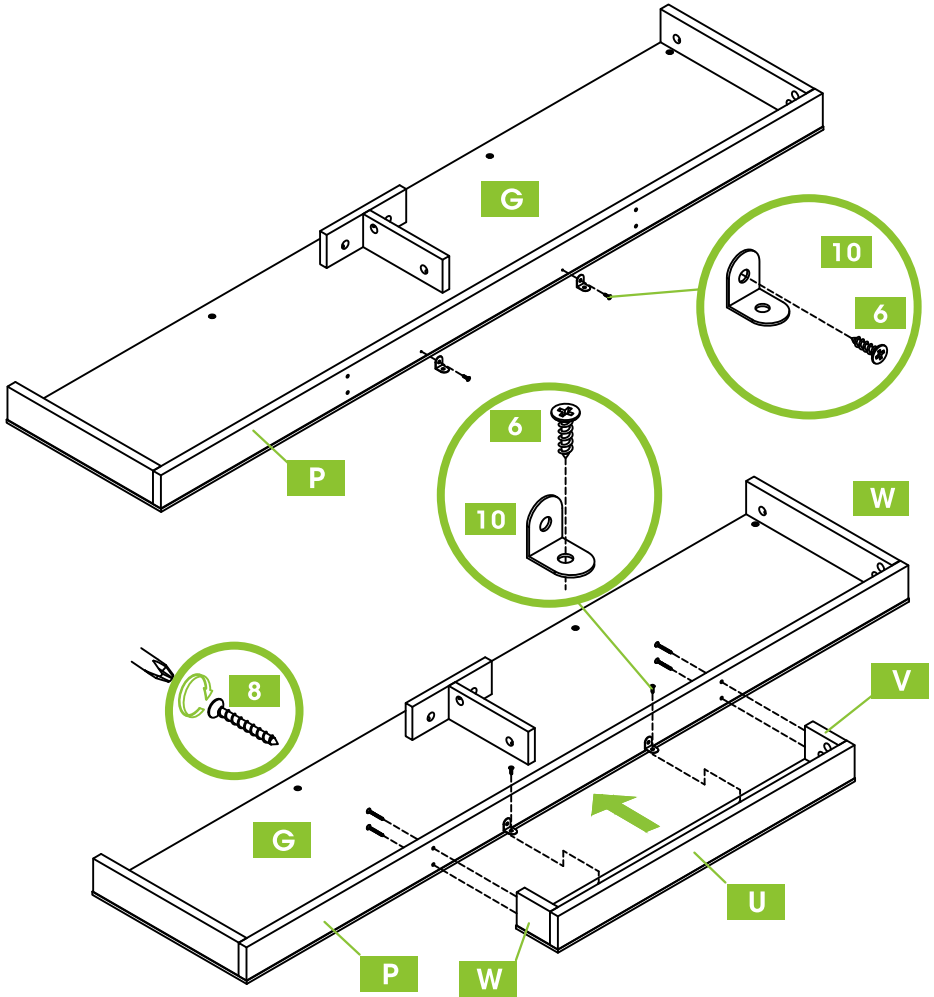
**12** NOTE: Install 2 part **10** with 4 self-tapping screws "**6**" as per diagram.  
Connect the two parts below with self-tapping screws "**8**" and "**6**".



PART	NO.	QTY.
	<b>6</b>	4
	<b>8</b>	4
	<b>10</b>	2

# PRODUCT ASSEMBLY

**13** NOTE: Connect the parts that have been installed with machine screws" **4** "

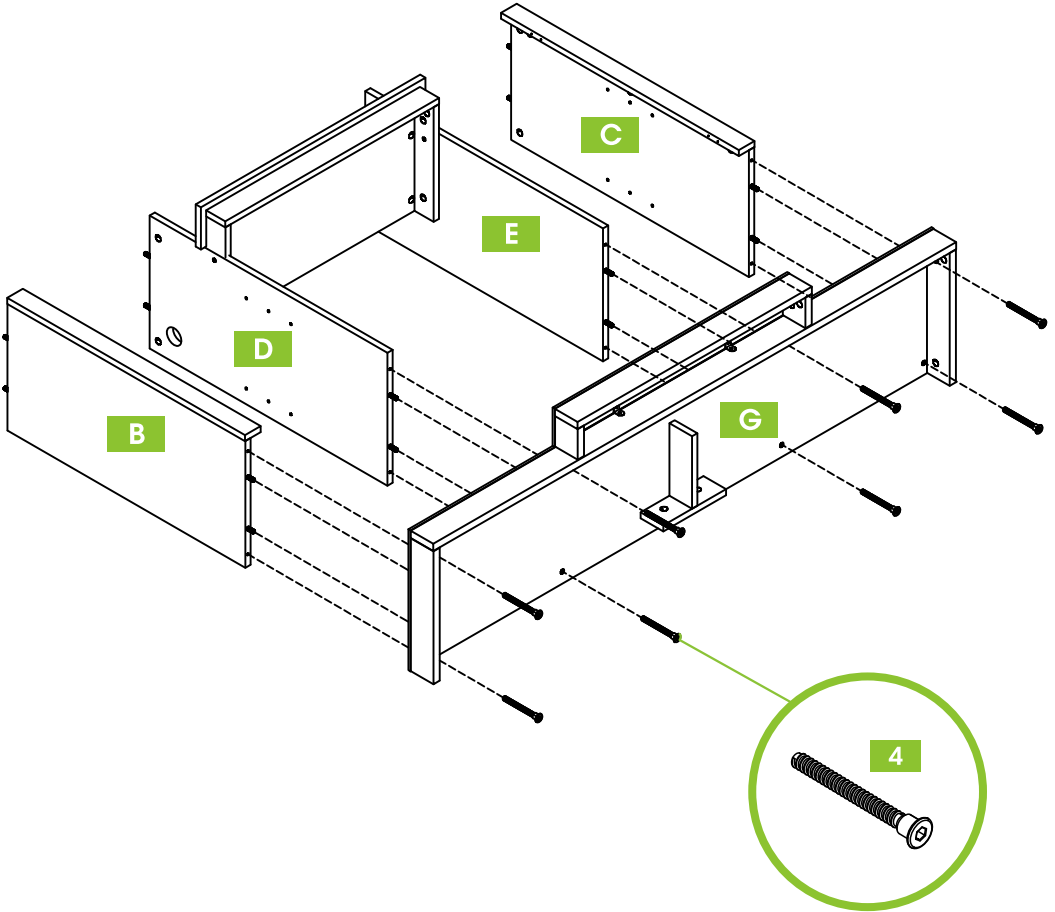

PART	NO.	QTY.
	4	8
	15	1

# PRODUCT ASSEMBLY

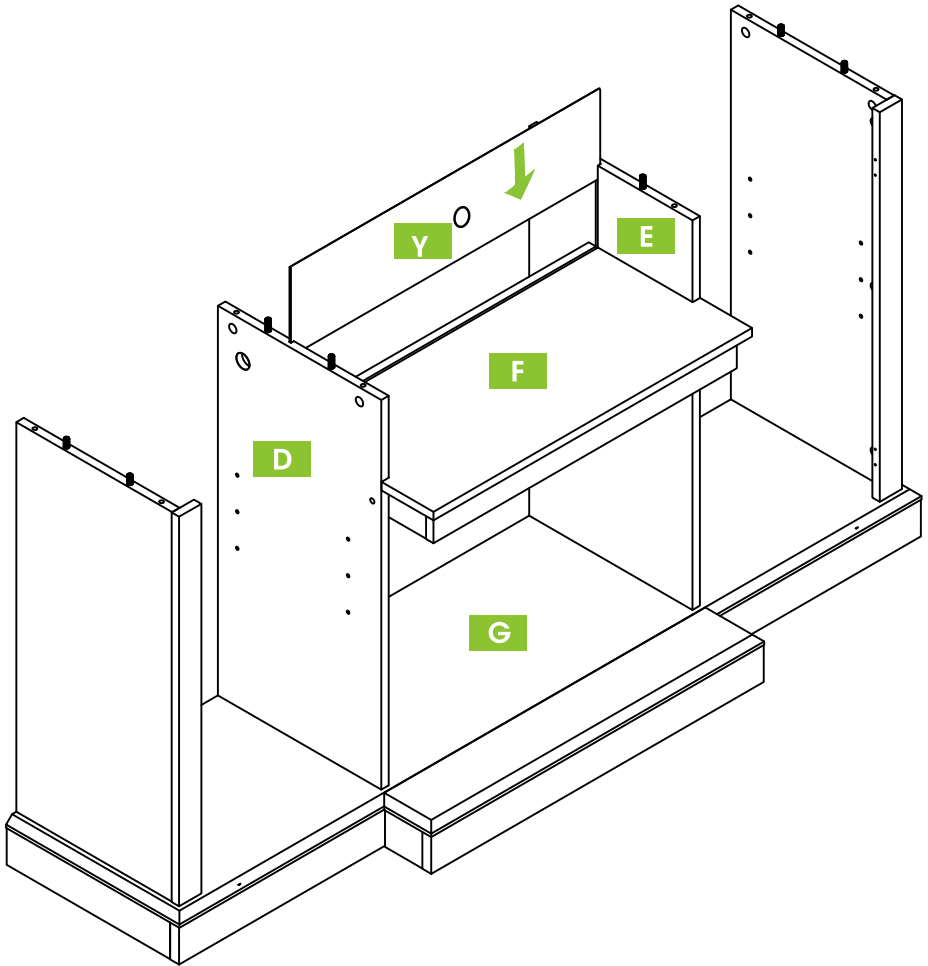

**14** NOTE: Push part Y along the slot to the end.

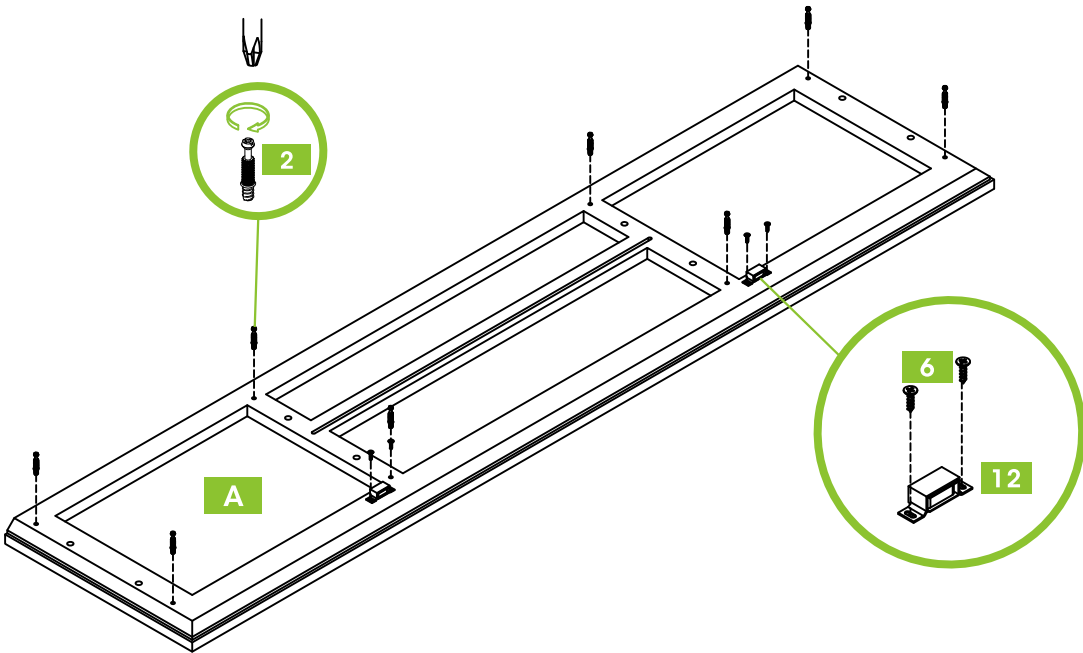

# PRODUCT ASSEMBLY

**15** NOTE: Install 8 cam bolt " **2** " on the corresponding holes of the part A as per diagram. Install part 12 with self-tapping screws " **6** " .



PART	NO.	QTY.
	<b>2</b>	8
	<b>6</b>	4
	<b>12</b>	2

# PRODUCT ASSEMBLY

**16** NOTE: Install 8 cam lock " **1** " on the corresponding holes of the part as per diagram.

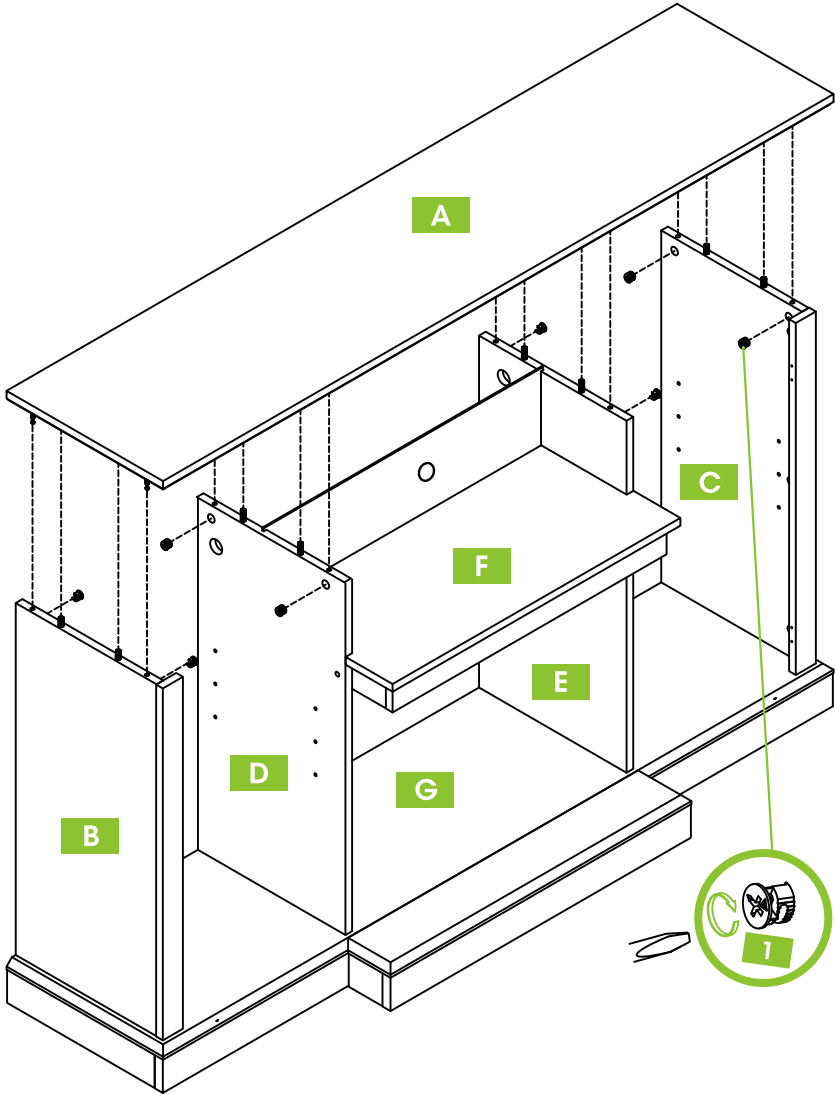

PART	NO.	QTY.
	1	8

# PRODUCT ASSEMBLY

**17** NOTE: Install 2 part X with self-tapping screws " **7** " corresponding to the corresponding holes.

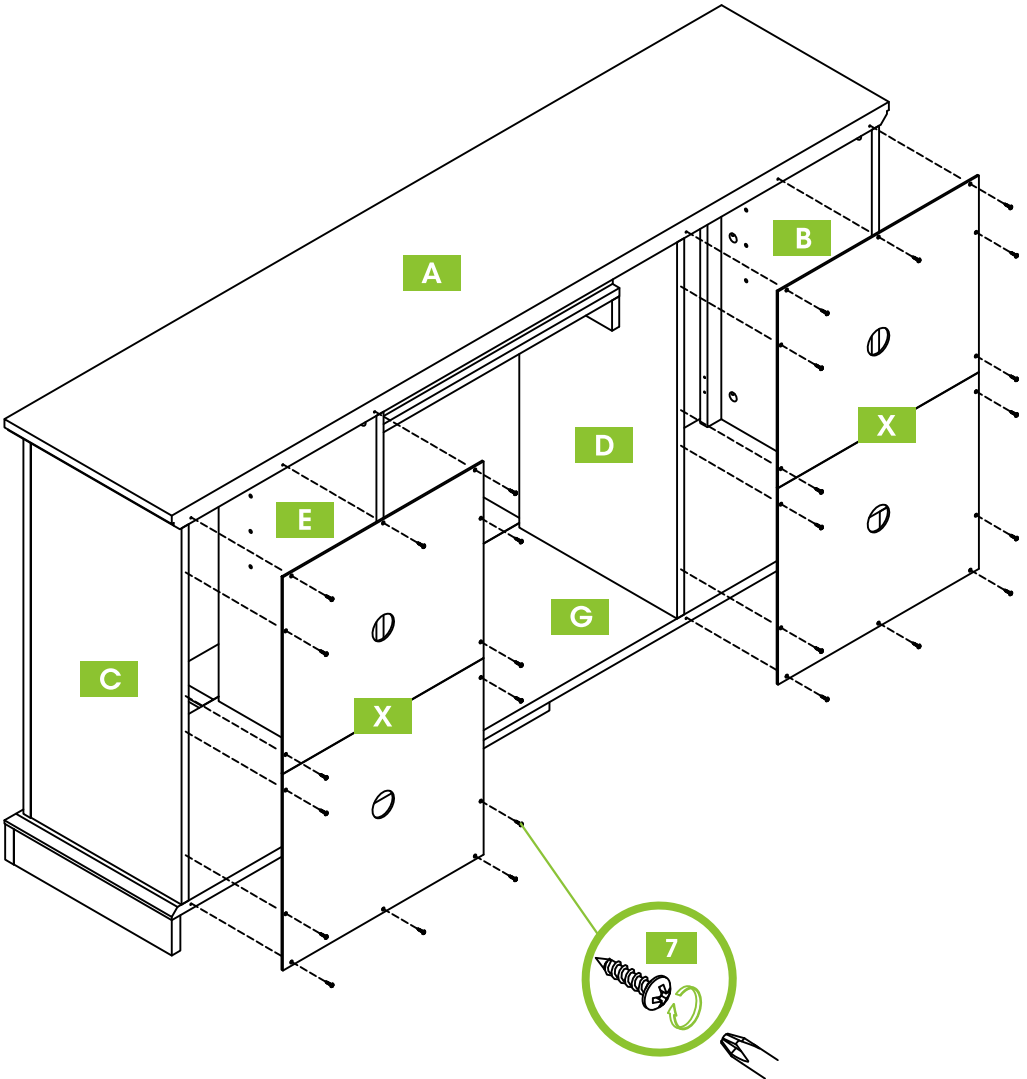



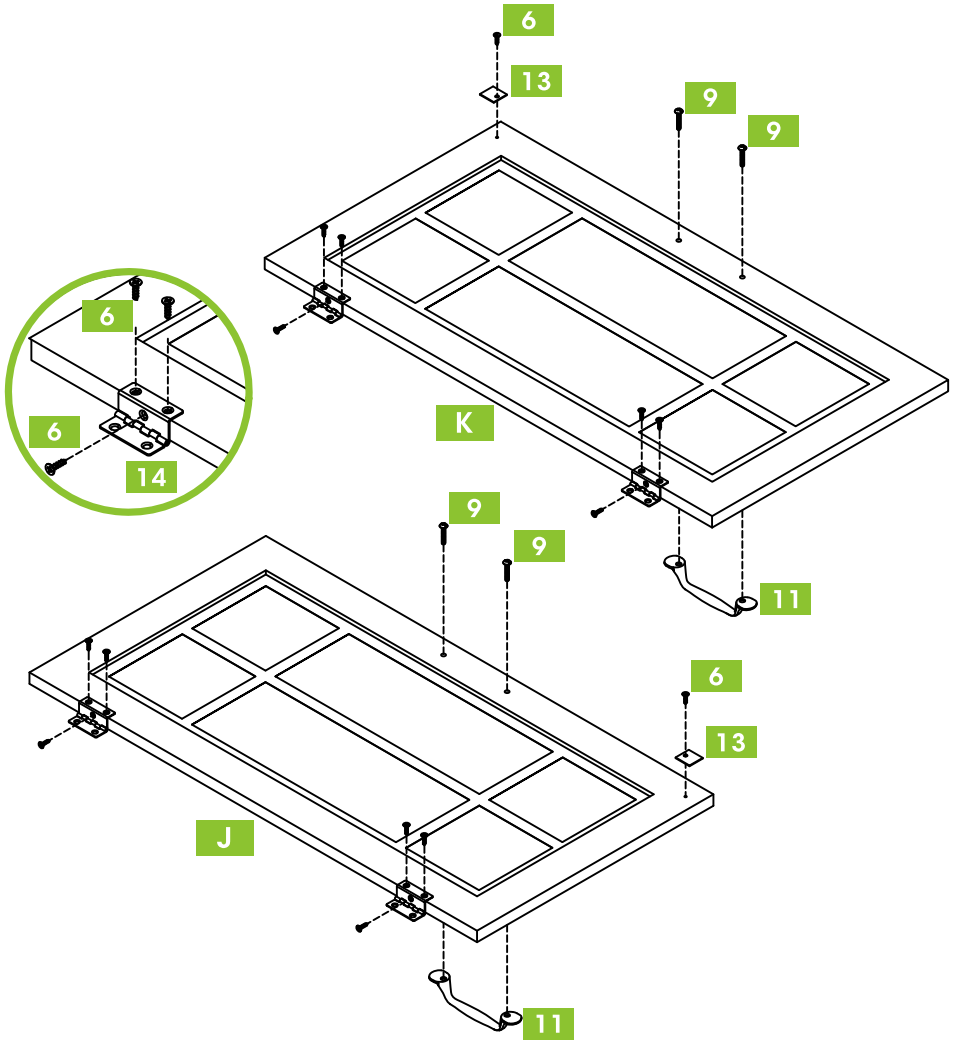

PART	NO.	QTY.
	7	28

# PRODUCT ASSEMBLY

**18** NOTE: Install appropriate fittings on both doors as per diagram.





PART	NO.	QTY.	PART	NO.	QTY.
	<b>6</b>	14		<b>13</b>	2
	<b>9</b>	4		<b>14</b>	4
	<b>11</b>	2			

# PRODUCT ASSEMBLY

19

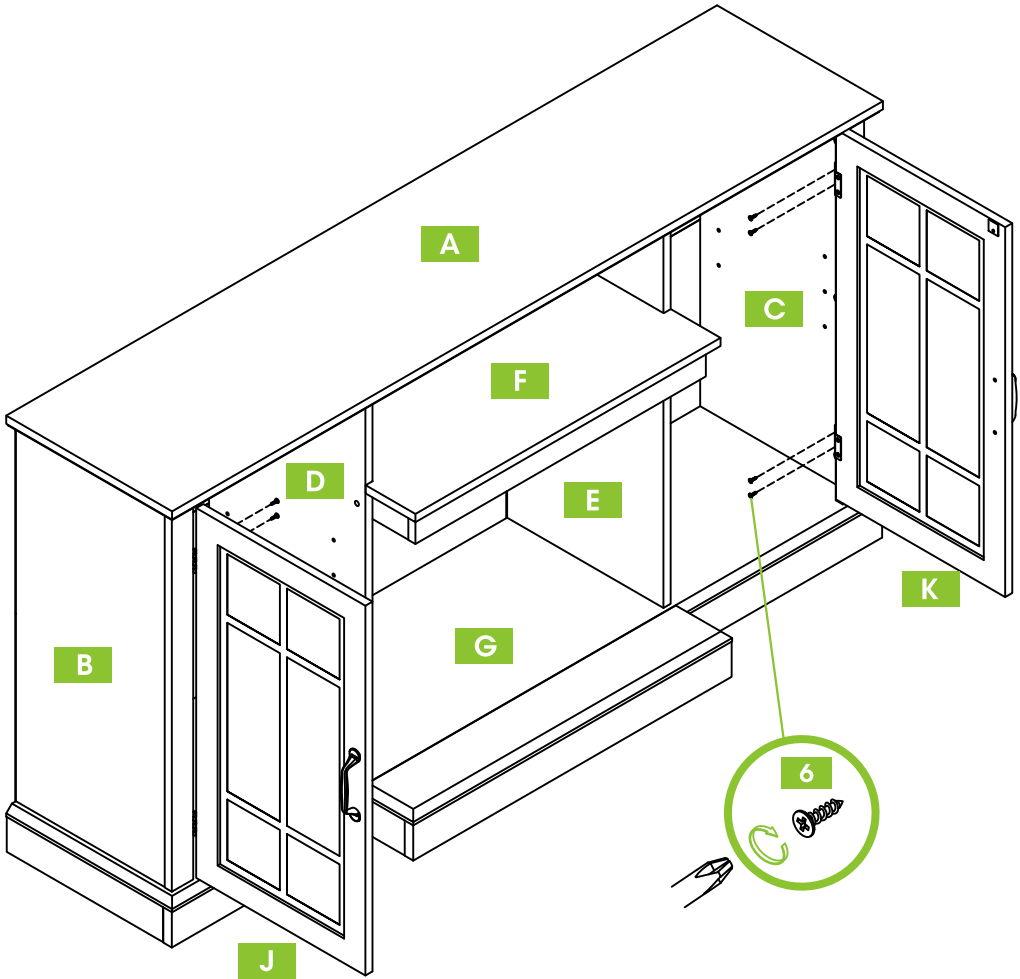
NOTE: Attach the door to the cabinet with self-tapping screws "6" as per diagram.



PART	NO.	QTY.
	6	8

# PRODUCT ASSEMBLY

**20** NOTE: Push two parts H in the cabinet.

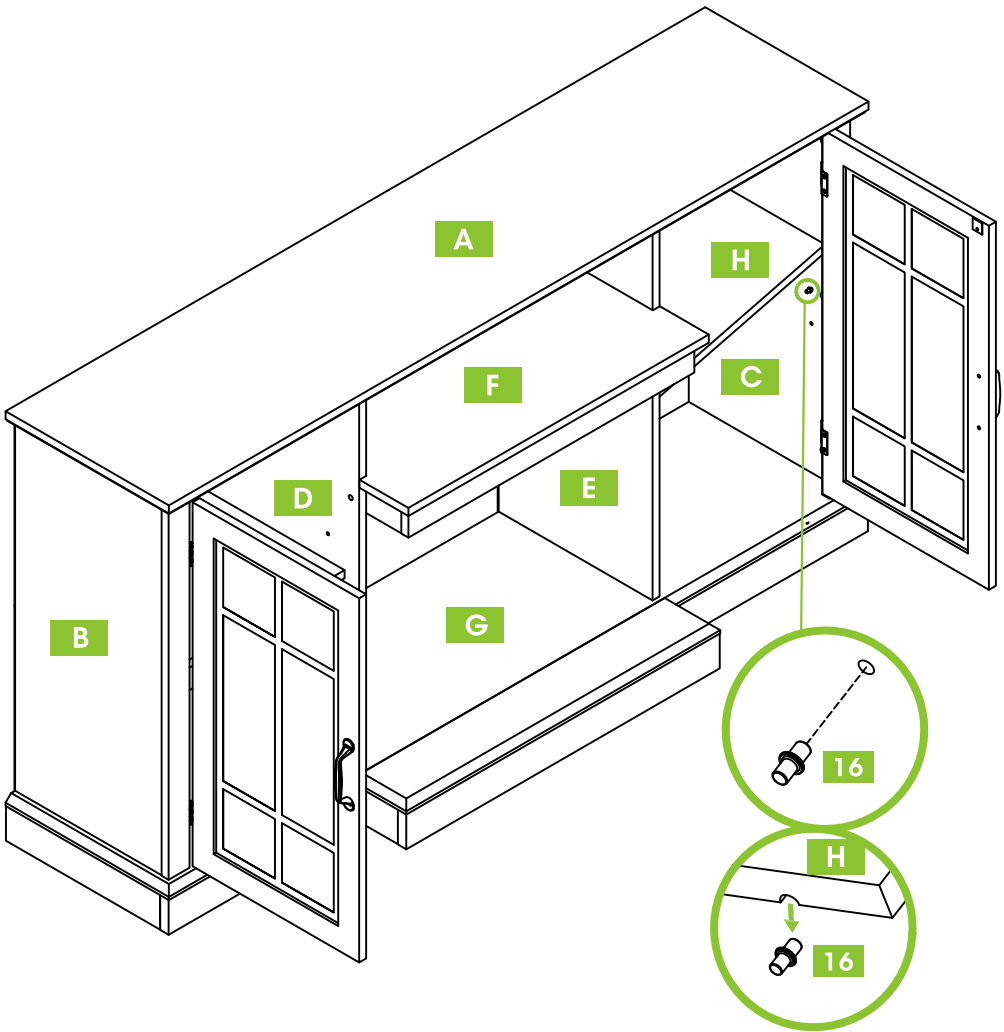

PART	NO.	QTY.
	16	8

# PRODUCT ASSEMBLY

		turns on and blows warm air.
	LED backlight button: Turn on LED backlight and change color	1. LED backlight button: Turn on LED backlight and change color. 2. NOTE: This button only on remote.

## INSTALLATION AND ASSEMBLY

1. Select a suitable location that is not susceptible to moisture.
2. Fix 2pcs of parts C on the fireplace by 4 screws (Fig. A)

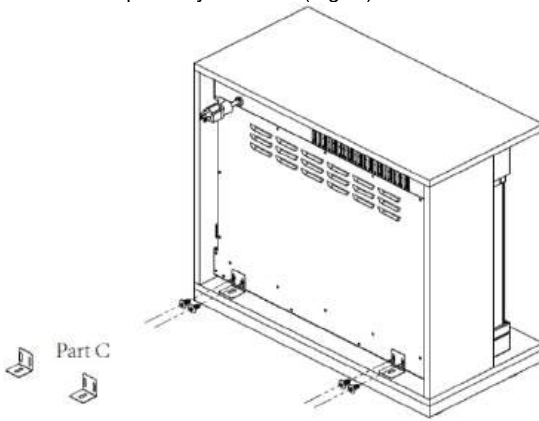

Fig. A

3. Fasten the fireplace on the mantel by 2 screws (Fig. B)

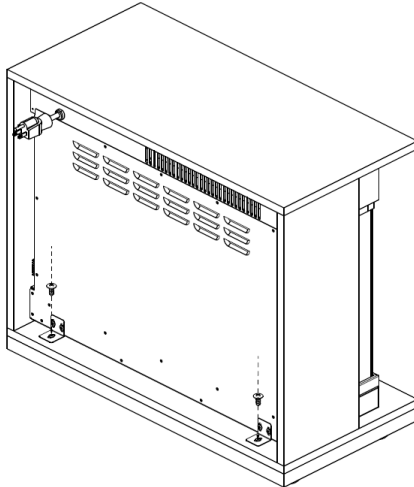

Fig. B

# HELP CENTER

Question about your product? We're here to help. Visit us at:



Chat Support



Product Inquiry

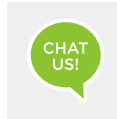

Orders FAQ



Product Assembly



Returns & Refunds

## We Stand Behind the Quality of Their Furniture

If you have any issues with your item please let us know! We will always do our best to come up with a solution that you will be happy with.

Please get in touch with our customer service team before returning the product.

And pls do not throw the original box(es) if you have not finished assembling or confirmed no quality issues.

Length of return period:

Items can be returned within 30 days of purchase.

In the meanwhile, everything you purchased from us comes with a one-year warranty.

Who is responsible for the return shipping fee:

We will cover the return shipping fees if:

1. Your item has a manufacturing defect in its materials or workmanship. For example, torn wicker or misaligned screw holes. We will send you a prepaid shipping label after photos are sent.
2. Your item has been damaged in transit. For example, glass is broken or wicker is damaged. We will send you a prepaid shipping label after photos are sent.
3. You receive the wrong box(es) due to a warehouse error. We will send you a prepaid shipping label after photos are sent of the wrong SKU numbers on the outer box(es).
4. One or more boxes are lost in transit. We will send you a prepaid shipping label if you no longer want the item.

\*However, we still hope to work with you for a better solution instead of a return. Please don't hesitate to contact our customer service team.

Customer will cover the return shipping fees if:

1. You don't like the product(s) after receiving the box(es).
2. You no longer need the product(s) but you have received the box(es).
3. You buy the product(s) by mistake but you have received the box(es).
4. Order/Shipment cancellation failed and you have received the box(es).

---

## Return Request

In order to get a full refund as described in this return policy, all items must be: (1) In a brand new/unused condition, please provide photos before and after packaging. (2) When returning, all accessories and parts are firmly packed in all original packaging.

If your return does not meet the requirements, you may not get a full refund.

When will I be refunded?

The refund is released once the goods have been returned to our warehouse.

What if the product is damaged/defective outside of the valid return period?

We want you to be a happy customer. Please reach out to us by email and we will come up with a solution to make sure you are satisfied.