

Assembly Instructions

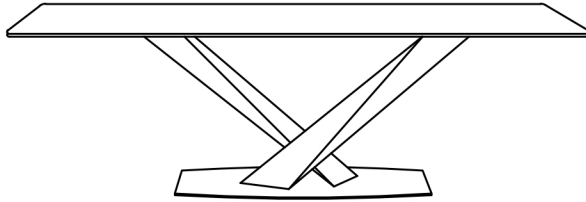

Thank you very much for purchasing our product.
Only initial defects, such as damaged or missing parts of this product, are covered under warranty.
In the event of any initial defects, please contact us via the message function of the store where you made your purchase.

1. Dining Table Parts List



Caution

This page includes accessory parts, including small parts required for assembly.



This symbol indicates a cautionary note.



Caution

- Before starting assembly, confirm that all parts are present.
- Proceed with assembly by matching the reference numbers in the diagrams with the markings on the actual parts.
- When assembling, ensure a sufficient work space and carry out the work with two or more people. There is a risk of injury if done alone.
- Be careful when handling the edges, rear sides, and gaps of parts. There is a risk of injury.
- Place a cloth or cardboard sheet on the floor before starting assembly, and work on top of it. There is a risk of damaging the floor.

For Correct Assembly

- Check the quantity of all parts
- Handle the product with care.

Items Required for Assembly

Protective material (to prevent damage to parts or the floor during assembly)



Cloth, cardboard, etc. *Please prepare these items yourself.

Before starting assembly, confirm that you have all the following accessories.

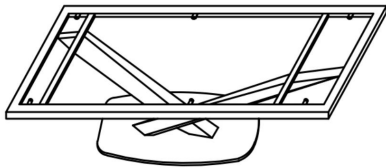

① Leg frame × 1

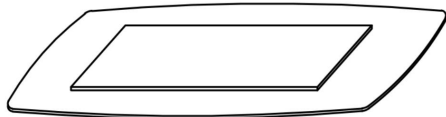

② Tabletop × 1



Tapping screws × 6

Tapping screws are special screws that can be driven directly into the material without pre-drilling a pilot hole.



Adjustable levelers × 6

For slight unevenness or height differences on the floor, adjust by turning the levelers.

2. Assembly Method Flow Chart

This page explains the product assembly procedure

- Prepare tools (The included hex wrench is required)
- Proceed while matching the part numbers on the diagrams with the actual parts.

Assembly Procedure

Step 1

With the side with the reinforcement plate facing upwards, place the tabletop flat on the floor.
(To avoid damaging the floor or tabletop, please lay a rug before working.)

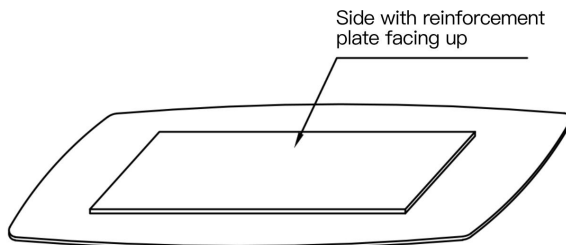

Step 2

Align the leg frame with the central position of the tabletop.
(The reinforcement plate is designed without screw holes.)

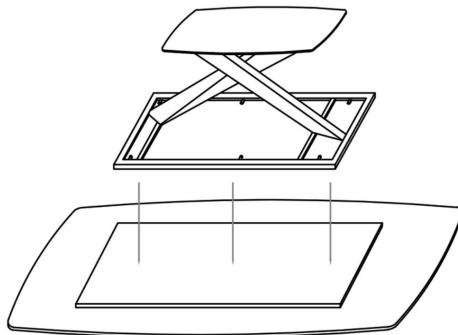

3. Assembly Method Flow Chart

This page explains the product assembly procedure.

- Prepare tools (The included hex wrench is required.)
- Proceed while matching the part numbers on the diagrams with the actual parts.

Assembly Procedure

Step 3

Insert the screws into the holes, apply pressure, and turn the screws clockwise to drive them in.

Tighten all screws securely

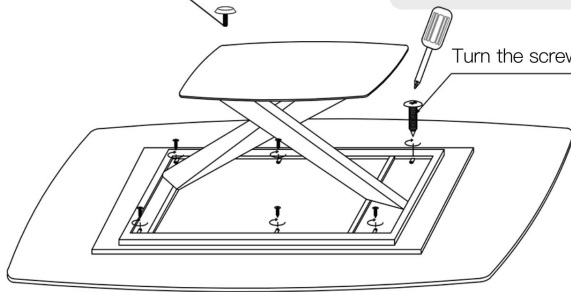

The screws are designed to be shorter than the reinforcement plate, so you can safely tighten them fully until there is no gap.

Turn the screw clockwise to drive it in

Shake the leg frame firmly to confirm there is no wobble, then turn the table back to its upright position.

OK

