

TOUGH TOOLS, HALF PRICE

Technical Support and E-Warranty Certificate

EXECUTIVE CHAIR USER MANUAL

We continue to be committed to provide you tools with competitive price. "Save Half", "Half Price" or any other similar expressions used by us only represents an estimate of savings you might benefit from buying certain tools with us compared to the major top brands and does not necessarily mean to cover all categories of tools offered by us. You are kindly reminded to verify carefully when you are placing an order with us if you are actually saving half in comparison with the top major brands.

EXECUTIVE CHAIR

TOUGH TOOLS, HALF PRICE

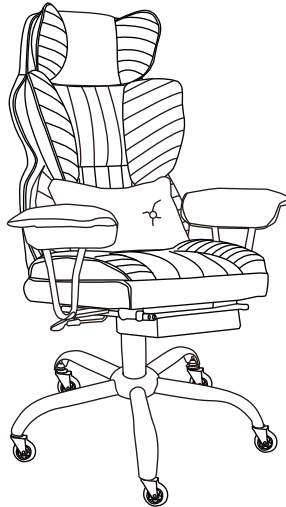

NEED HELP? CONTACT US!

Have product questions? Need technical support? Please feel free to contact us:

Technical Support and E-Warranty Certificate

This is the original instruction, please read all manual instructions carefully before operating. reserves a clear interpretation of our user manual. The appearance of the product shall be subject to the product you received. Please forgive us that we won't inform you again if there are any technology or software updates on our product.

SAFETY INSTRUCTIONS

WARNING:

Read this instructions carefully before using this product. Failure to do so can result in serious injury.

Assembly precautions









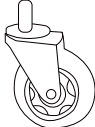
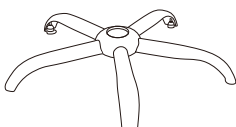

1. Assemble only should be according to these instructions. Improper assembly can result in hazards.
2. Wear ANSI-approved safety goggles and heavy-duty work gloves during assembly.
3. Keep the assembly area clean and well-lit.
4. Keep bystanders out of the area during assembly.
5. Do not assemble when tired or when under the influence of alcohol, drugs or medication.
6. The product capabilities apply to properly and completely assembled products only.
7. Assemble on a flat, level, hard and smooth surface capable of safely supporting the executive chair.
8. For additional information regarding the parts listed in the following pages, please refer to the Assembly Diagram of this manual. Unwrap and separate all parts in a clean work area.

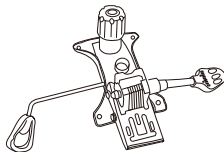
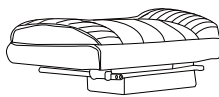
Use precautions



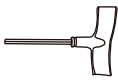

1. Do not exceed weight capacities.
2. Use only on a flat, level, hard and smooth surface capable of safely supporting a fully loaded executive chair.
3. Use as intended only.
4. Inspect before every use; do not use if parts are loose or damaged.

SAVE THESE INSTRUCTIONS

PARTS LIST

(1)	(2)	(3)		
				
Caster : 5 pcs	Base : 1 pc	Gas Lift : 1 pc		
(4)	(5)	(6)		
				
Gas Lift Cover : 1 pc	Seat Plate : 1 pc	Seat Cushion : 1 pc		
(7)	(8)	(9)		
	8-R 8-L 			
Back Cushion : 1 pc	Armrest: 1 Pair	J-Bar: 1 pc		
		(10)		
				
		Lumbar Support : 1 pc		
Hardware				
A	B	C	D	E
				
1/4x1" Screw : 4 pcs	1/4x1-1/4" Screw : 8 pcs	1/4x1-1/8" Screw : 4 pcs	5/16x1-1/4" Screw : 4 pcs	Wrench : 1 pc

Spare Parts

			
1/4x1" Screw : 1 pc	1/4x1-1/4" Screw : 1 pc	1/4x1-1/8" Screw : 1 pc	5/16x1-1/4" Screw : 1 pc

ASSEMBLY STEP

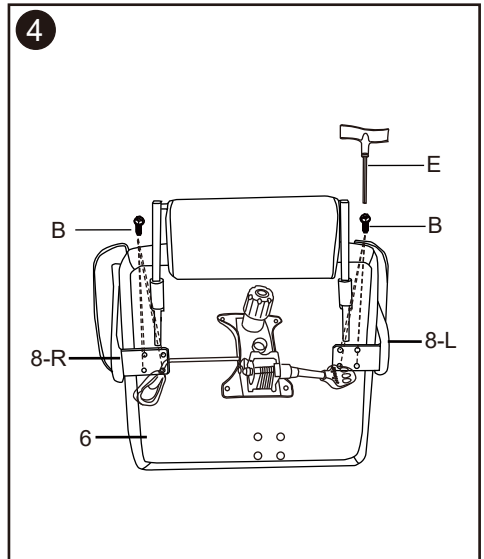
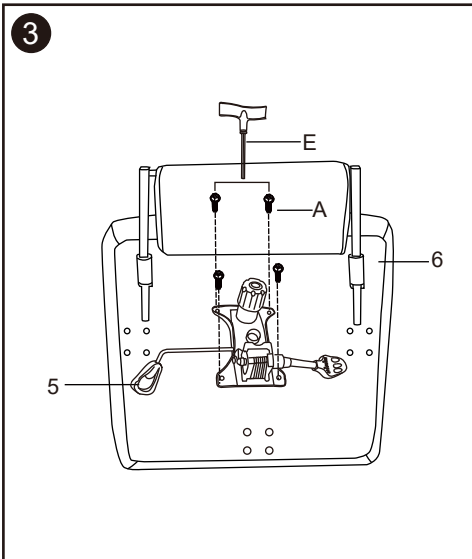
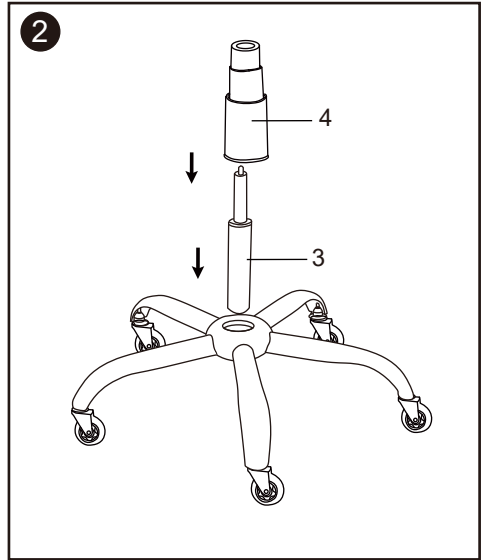
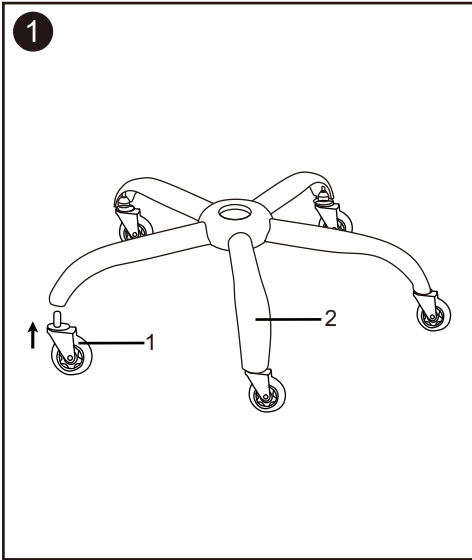

5

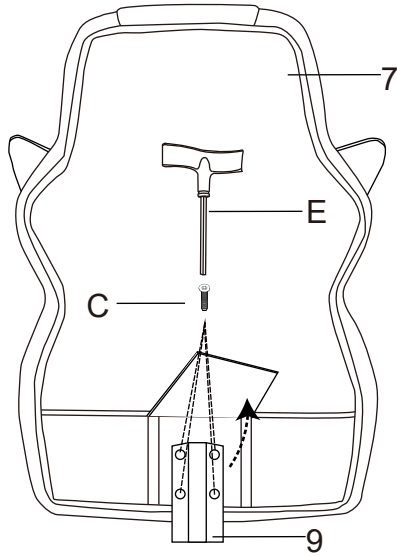

6

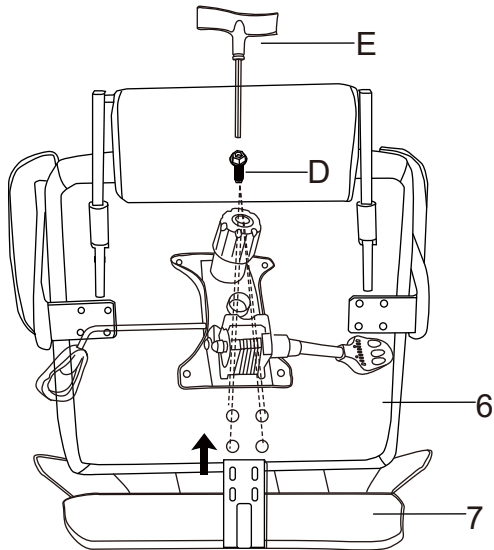

7

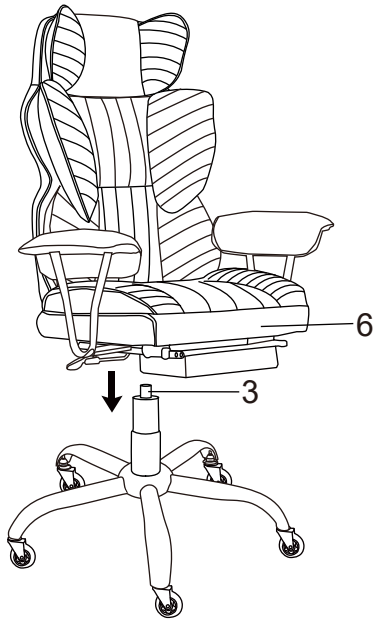

8

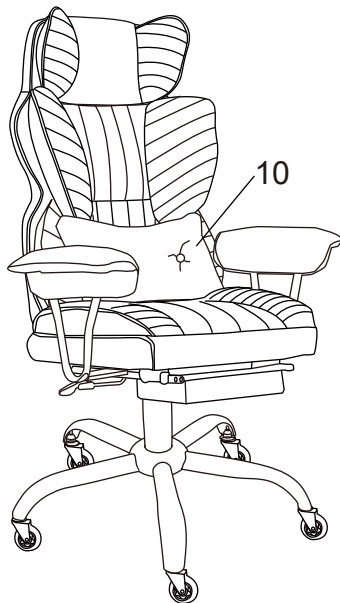

PRODUCT PARAMETER

Package size (mm)	890*700*405
Size (mm)	740W*790D*1250H
N.W (kg)	23.6
G.W (kg)	28.2
Colour	White
Lifting range	≤100mm
Backrest height	860 mm
Backrest width	650 mm
Cushion width	600 mm
Cushion deep	520 mm
Castor material	PU
Main Material	Iron+PU+High rebound sponge
Load-bearing	≤350 lbs