

ASSEMBLY INSTRUCTION

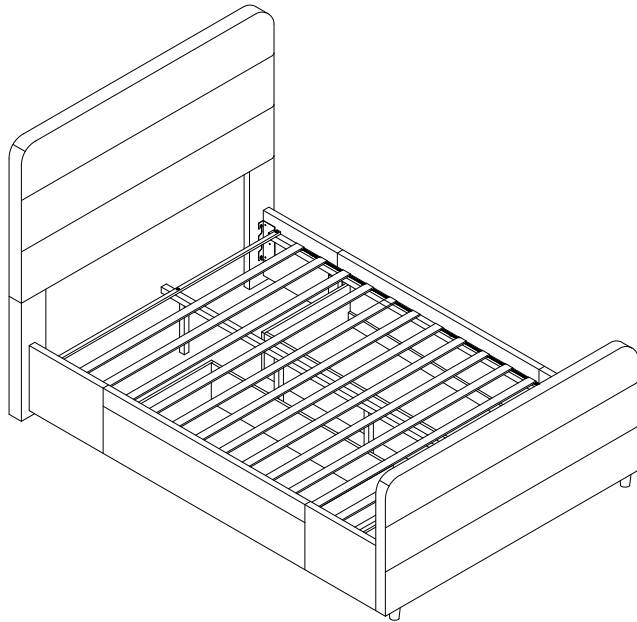

Please **TEAR OFF** this shrink film from side!
DO NOT USE CUTTER!

ITEM NUMBER: BD004

IMPORTANT NOTE

- 1. The product is shipped in two packages. Please check the number of packages received before assembly. If you are missing one package, receive a duplicate package, or have any assembly or after-sales issues, please contact support@velocavabed.com**
2. For the protection of your furniture, place all parts on a clean and smooth surface to prevent any damage.
3. Keep fittings out of children's reach and keep children well away from construction area.
4. When moving your assembled bed, it is best to lift the bed and never to drag it.
5. Do not use this product if parts are missing, damaged or worn.
6. This product should only be used on firm, level ground.
7. Please periodically check all fittings and re-tighten as necessary.
8. Do not use the bed unless all bolts and screws are firmly secured.
9. For further assistance, please provide a screenshot of your order and contact us via email at support@velocavabed.com

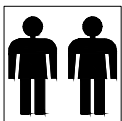

Minimum two
person assembly

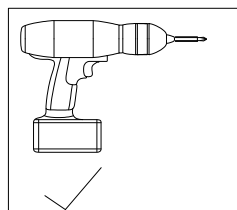

PART LIST

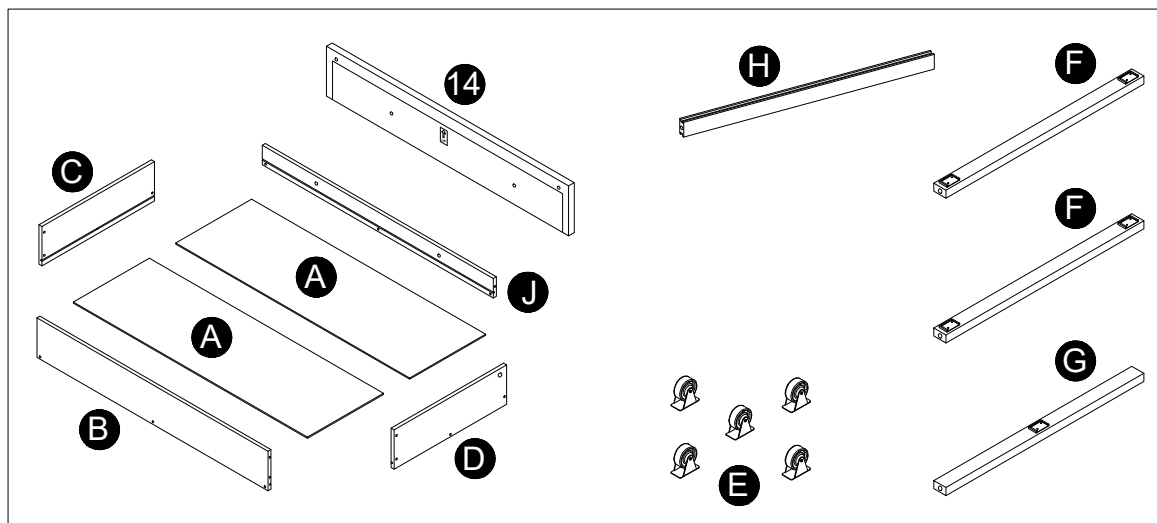
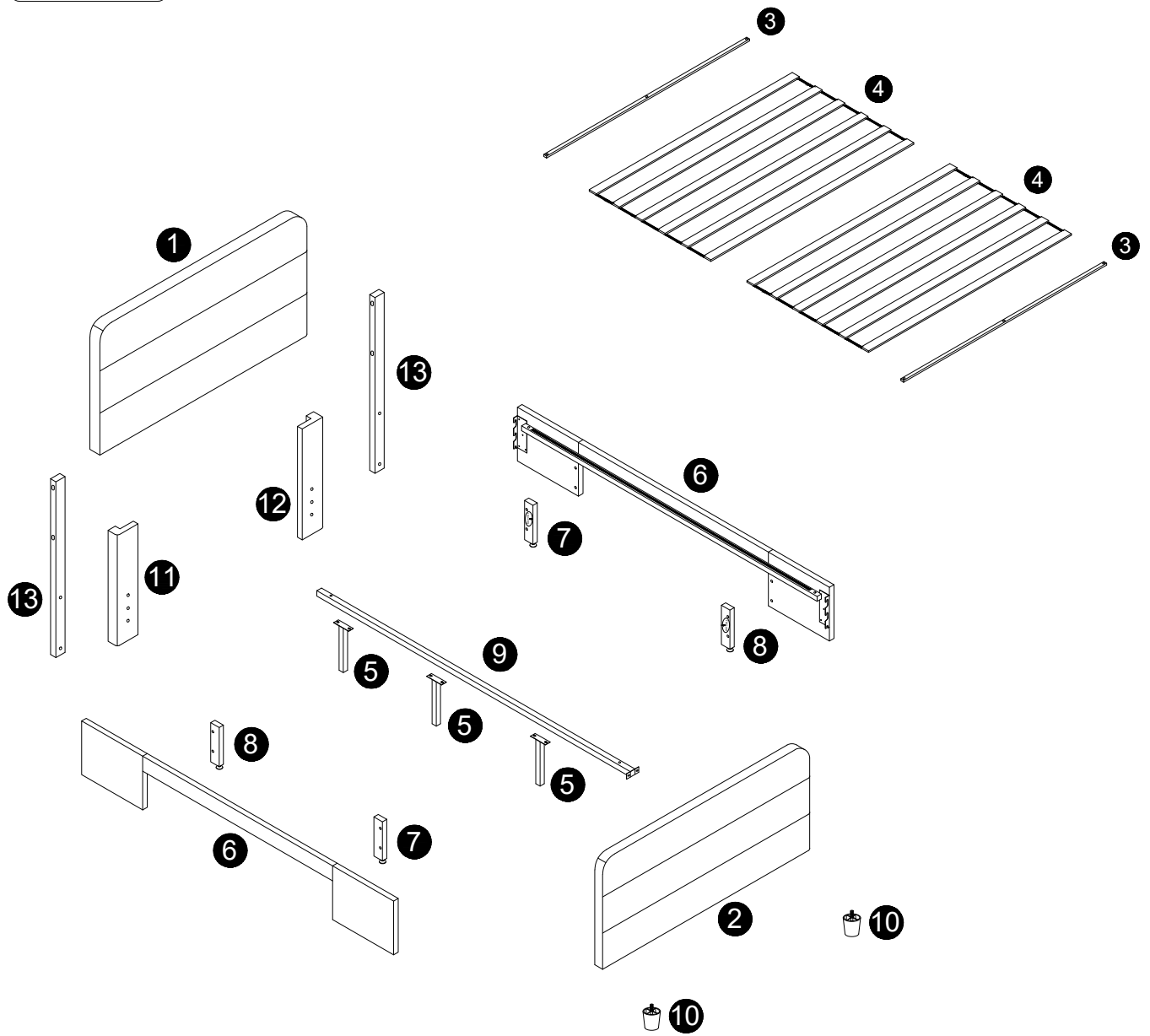

x2

Components of Carton A

1 x 1pc

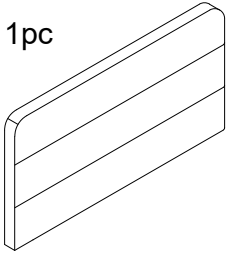

2 x 1pc

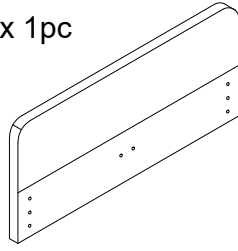

Components of Carton B

3 x 2pcs

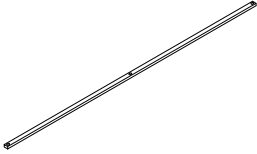

4 x 2pcs

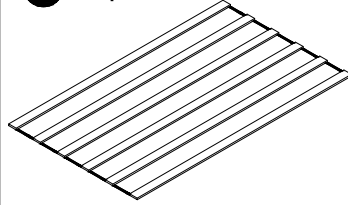

5 x 3pcs

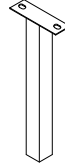

6 x 2pcs

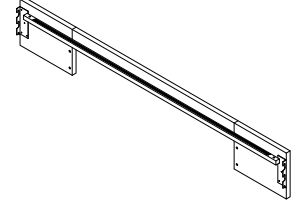

7 x 2pcs

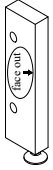

8 x 2pcs

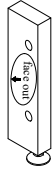

9 x 1pc

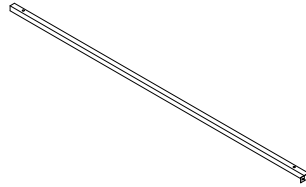

10 x 2pcs



11 x 1pc



12 x 1pc



13 x 2pcs



14 x 2pcs

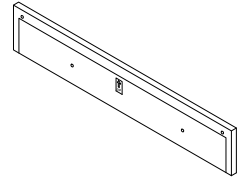

A x 4pcs

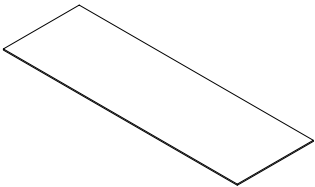

B x 2pcs

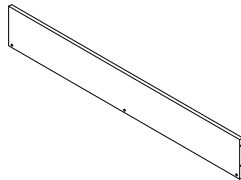

C x 2pcs

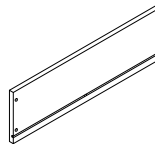

D x 2pcs

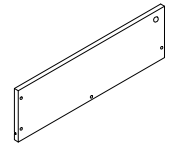

E x 10pcs



F x 4pcs

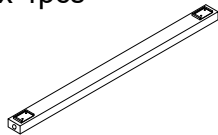

G x 2pcs

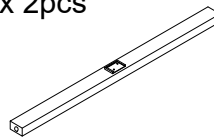

H x 2pcs

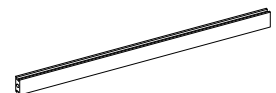



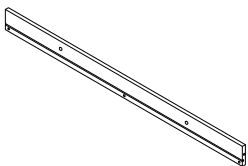





J x 2pcs

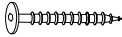
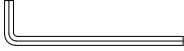
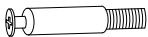

Please ensure to thoroughly inspect the small inner cardboard box containing the hardware, which are tied with a red string, before disposing of the box.

HARDWARE LIST

 H1 M5 x 1pc	 H2 M8x25mm x 20pcs	 H3 M8x35mm x 18pcs	 H4 M8x55mm x 4pcs
 H5 M8 x 6pcs	 H6 M8x22mm x 14pcs	 H7 M8x30mm x 4pcs	 H10 M6x45mm x 28pcs
 H11 M4 x 1pc	 H12 x 4pcs	 H13 x 4pcs	

1

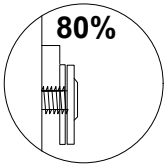
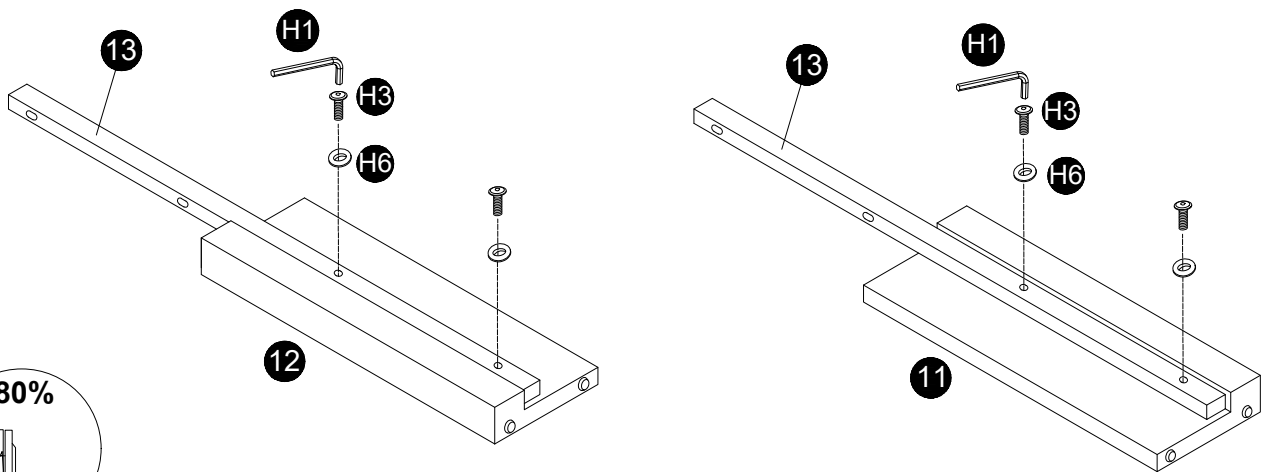

Do not fully tighten fixings!

2

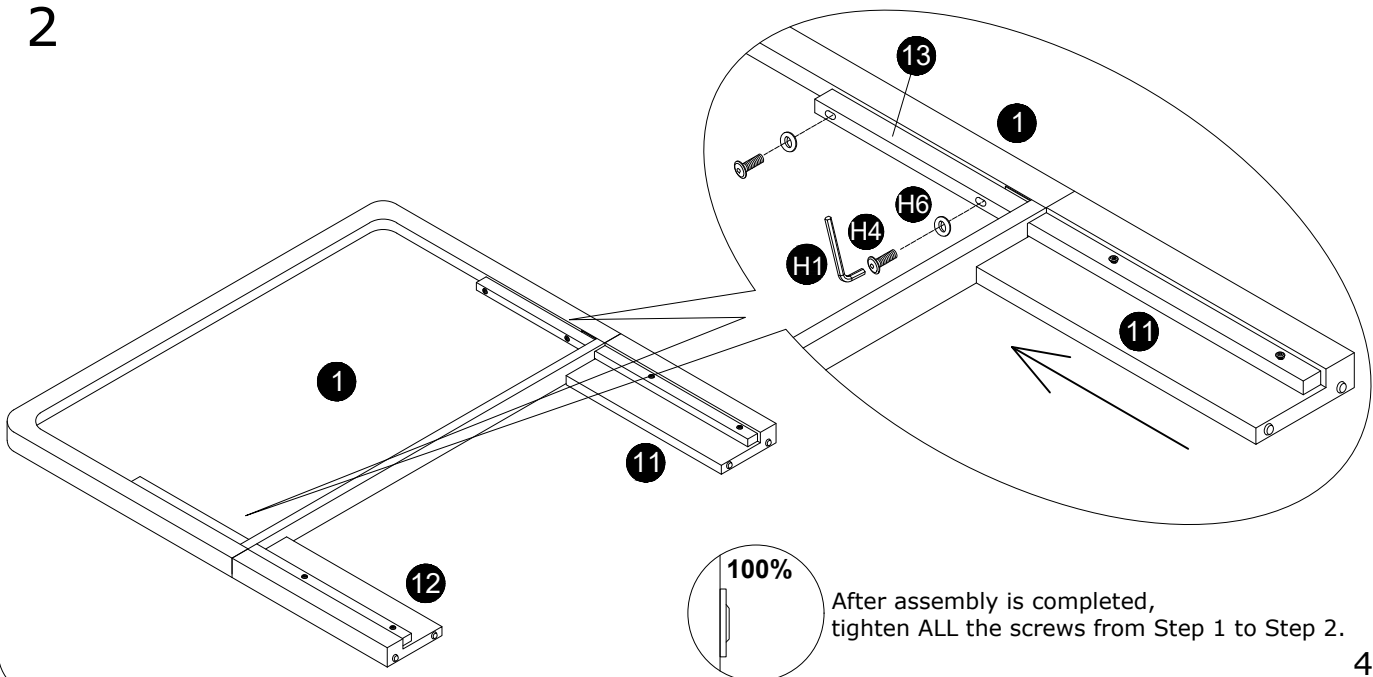

After assembly is completed, tighten ALL the screws from Step 1 to Step 2.

3

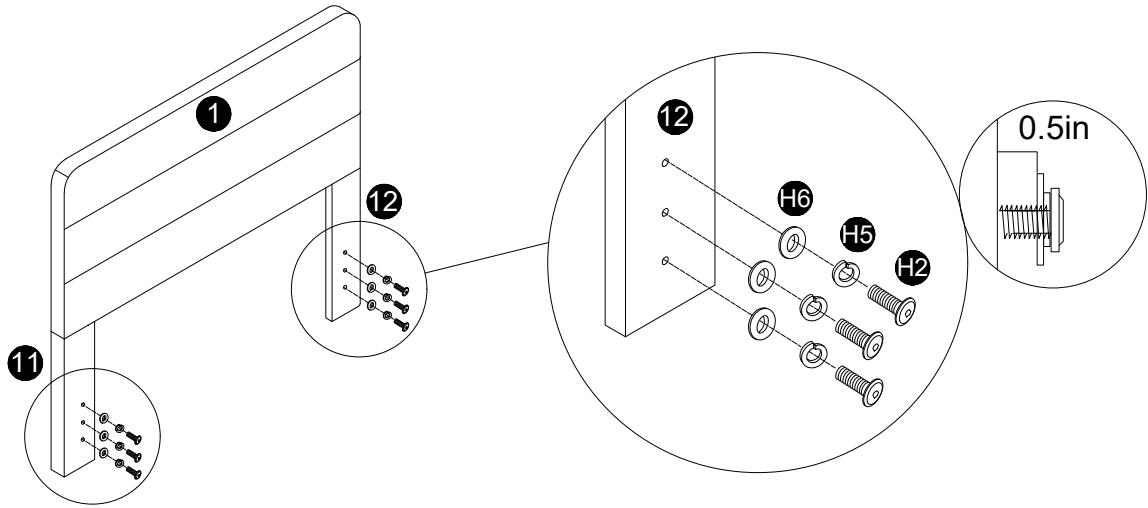

4

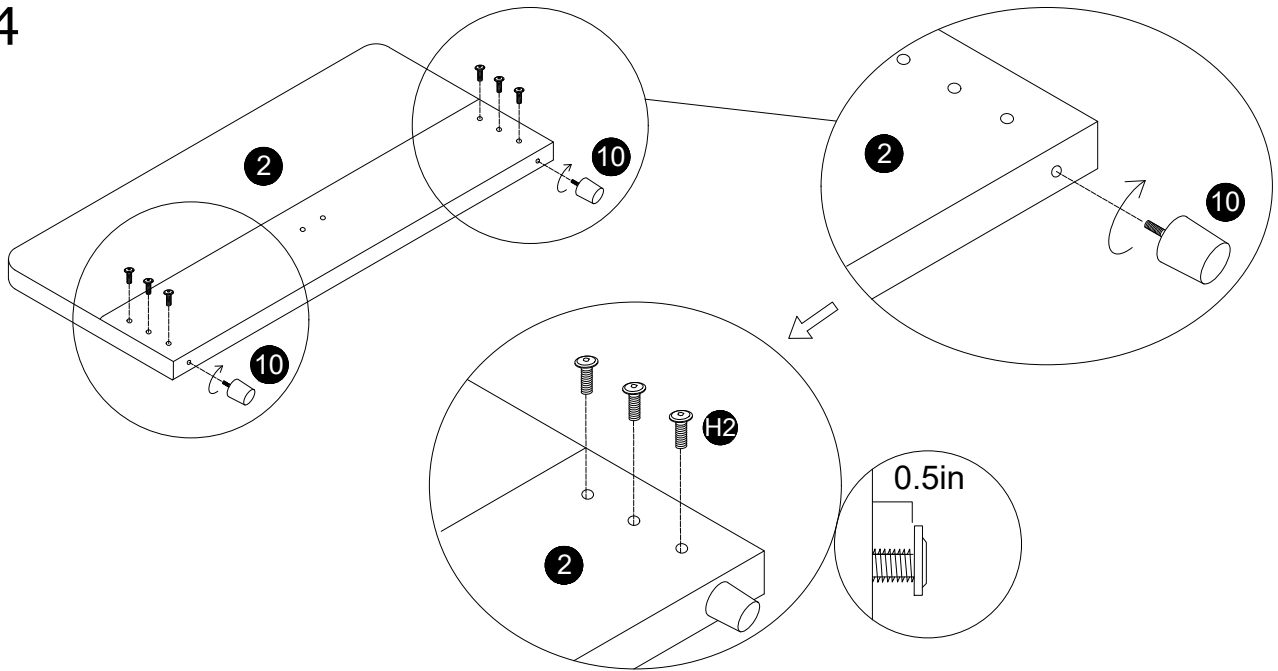

5

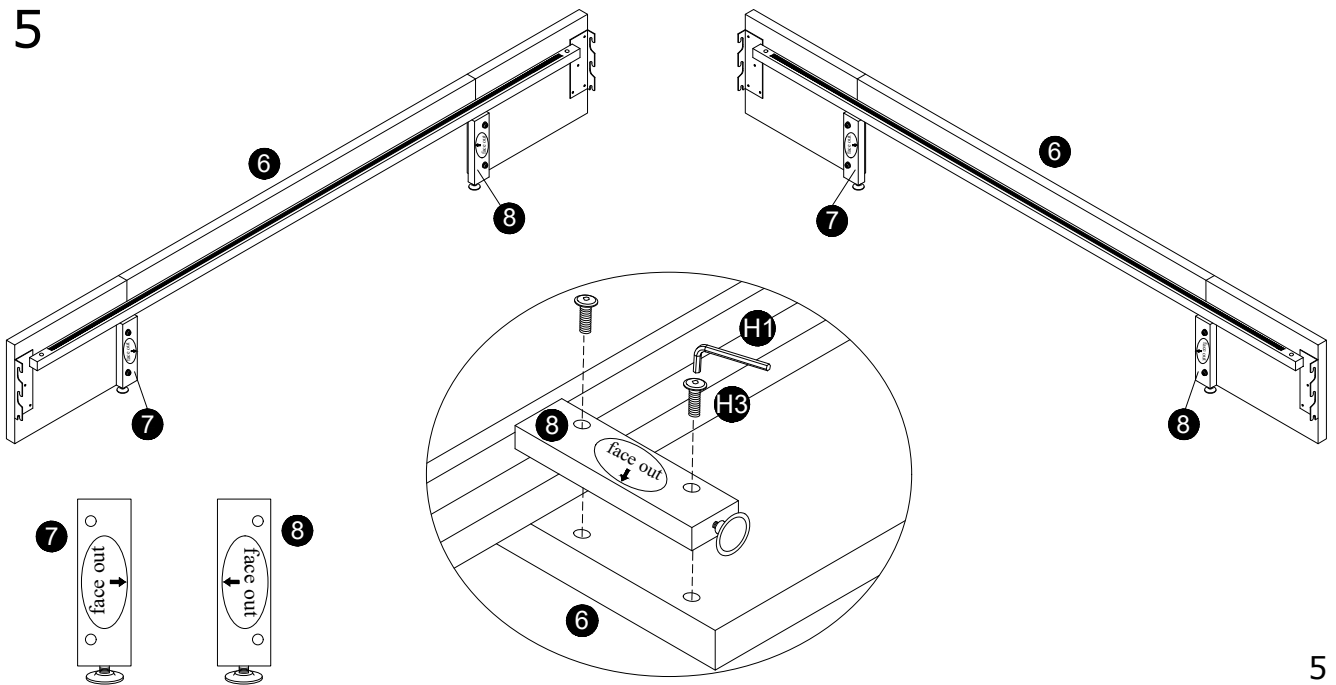

5

6

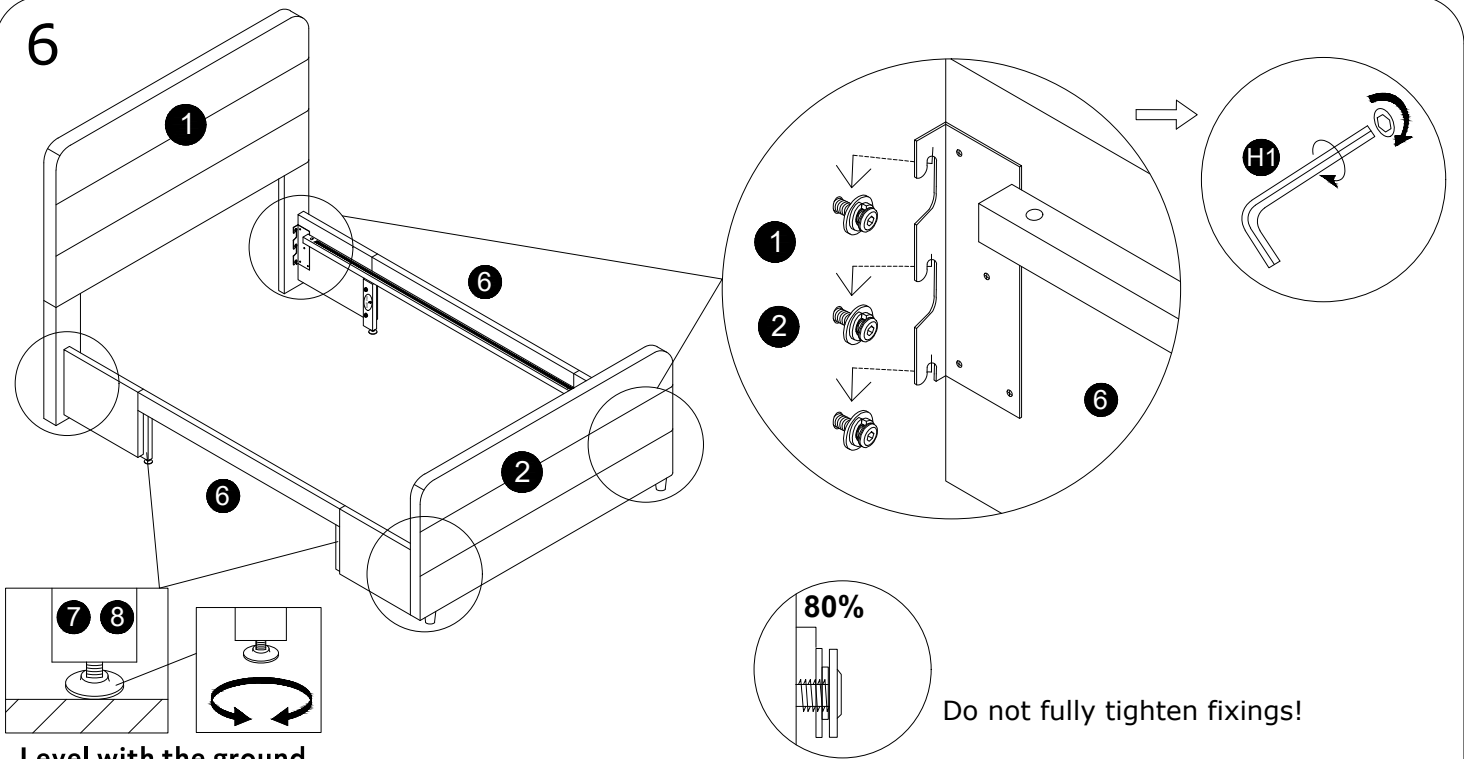

Level with the ground.

Do not fully tighten fixings!

7

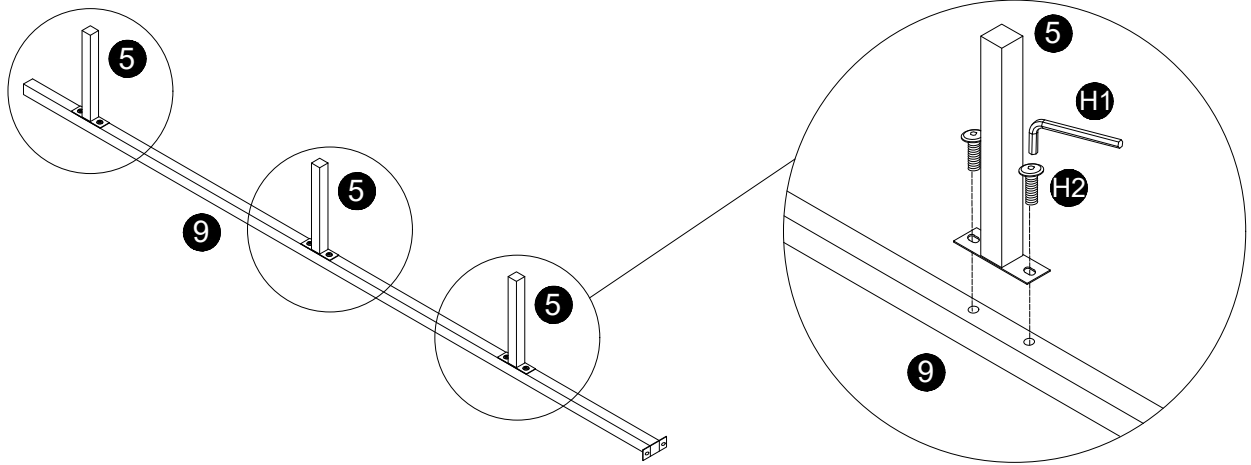

8

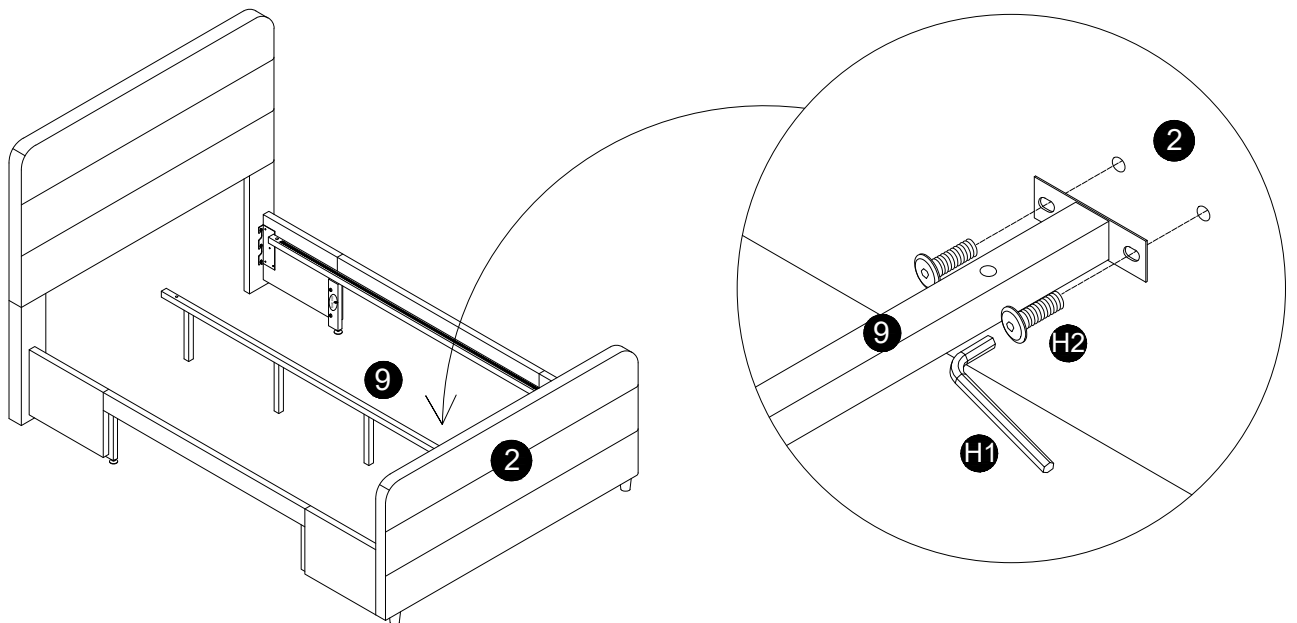

9

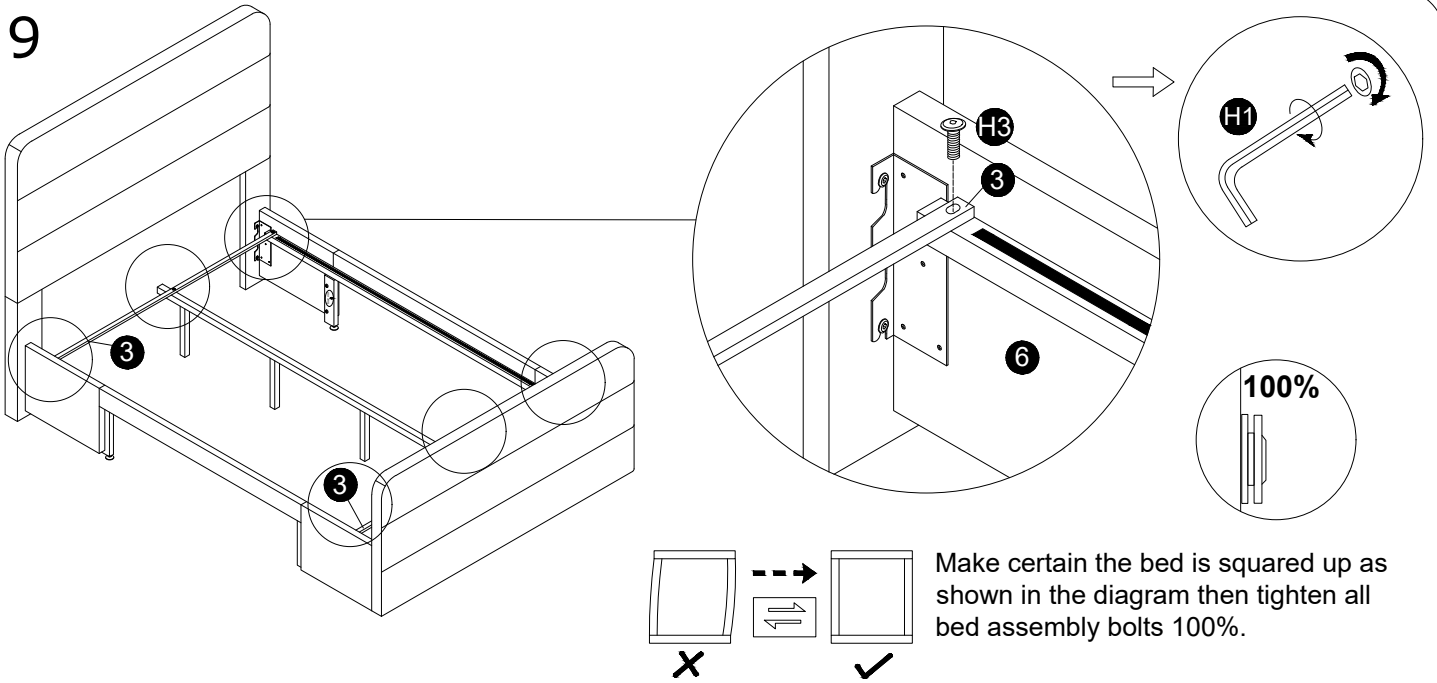

10

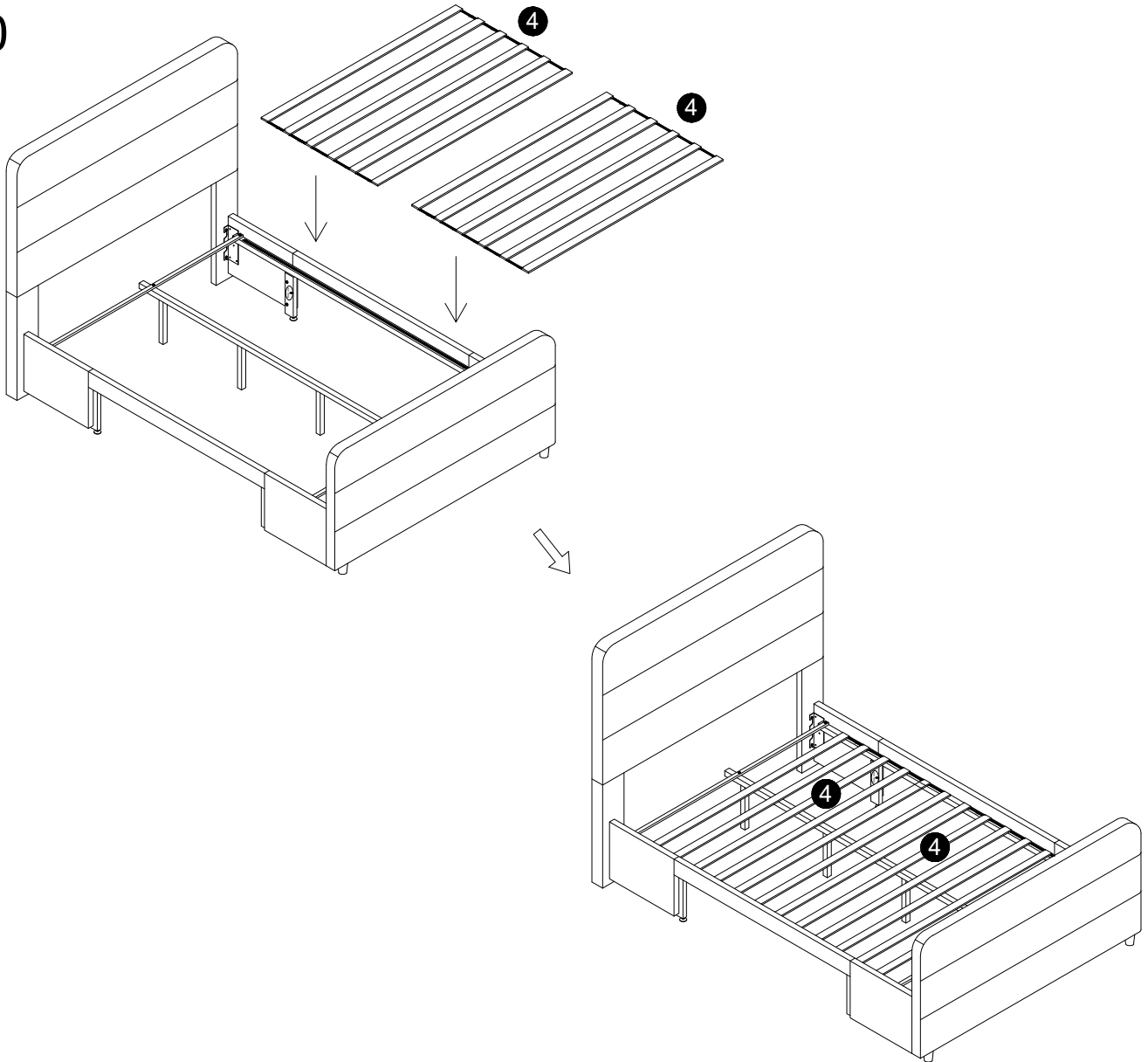

11

Grooves to align

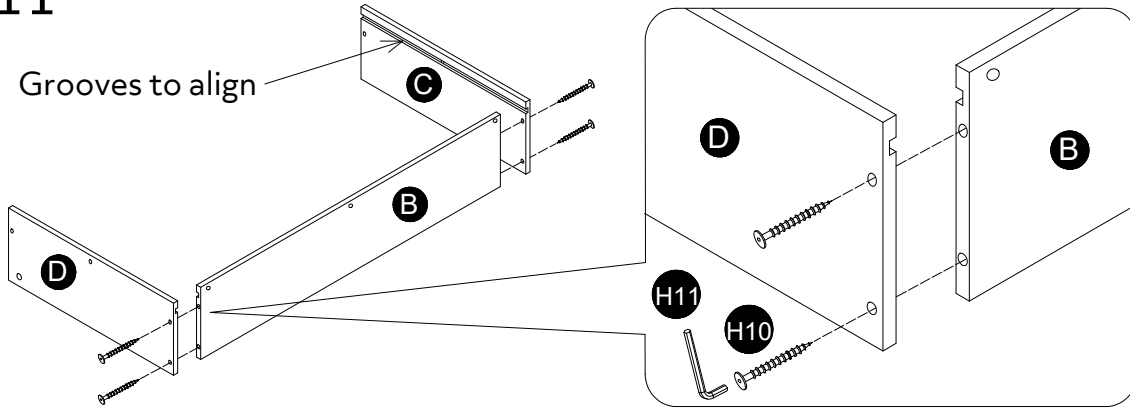

x2

12

a:

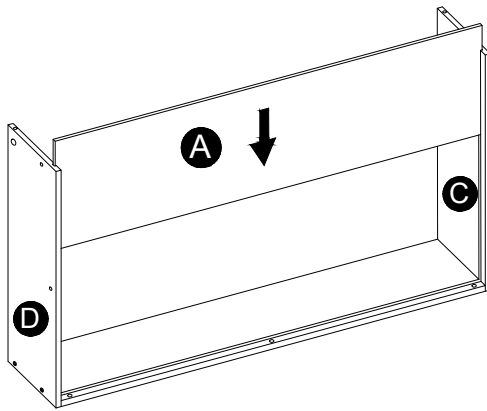

x2

b:

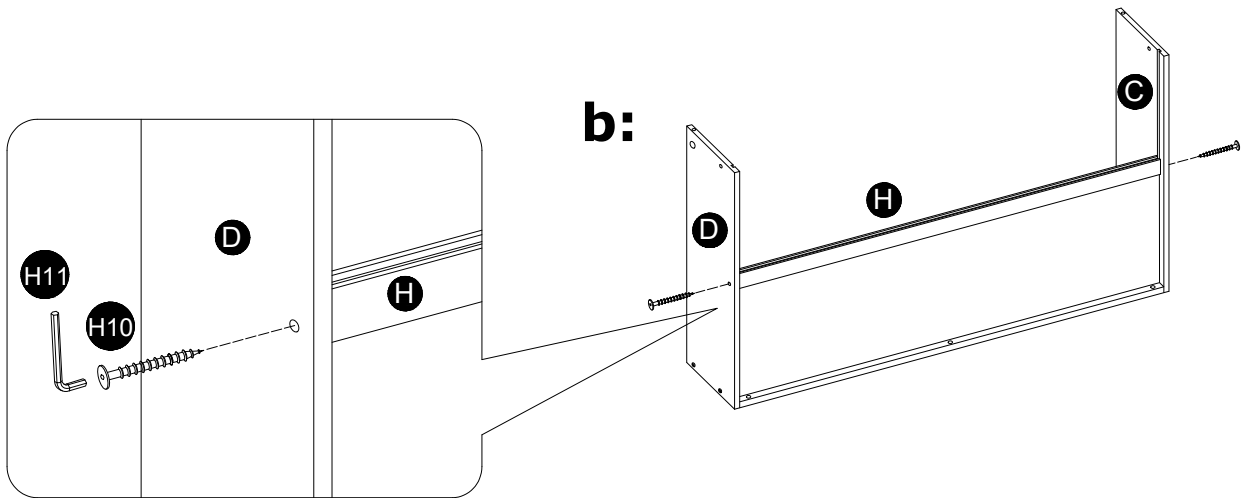

c:

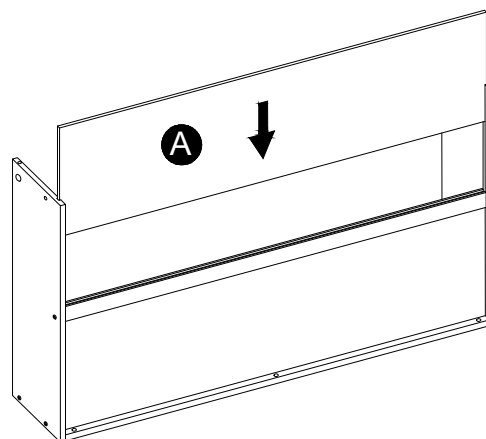

13

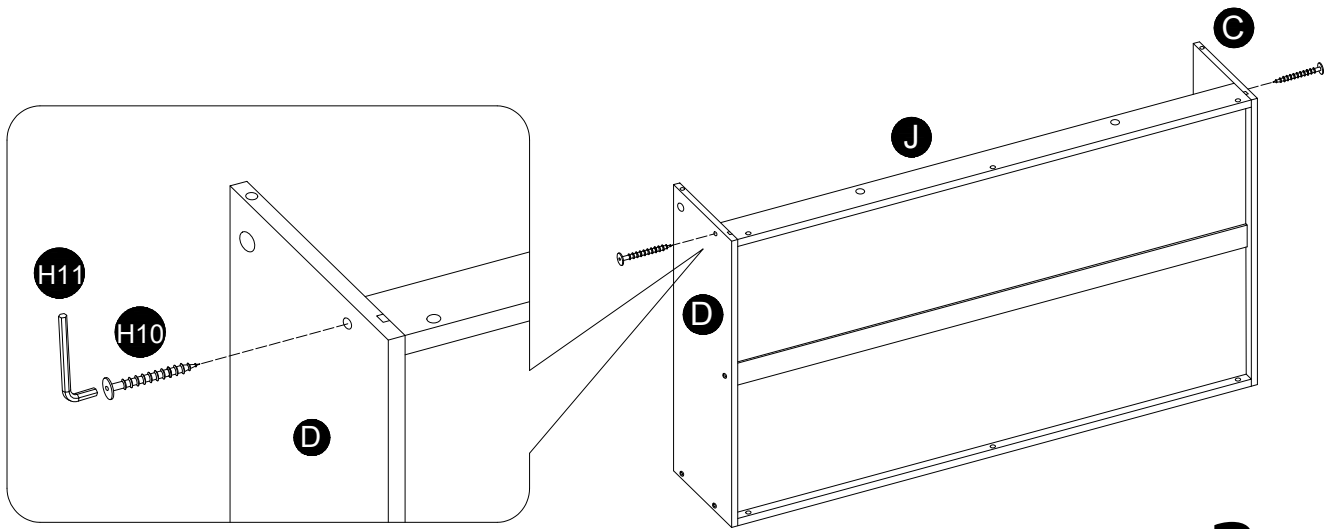

x2

14

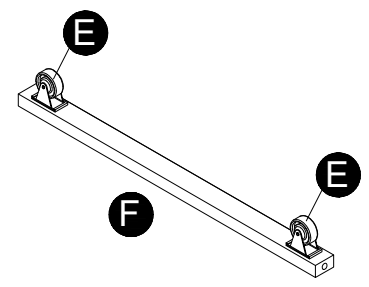
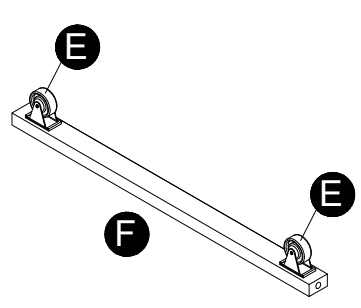

x2

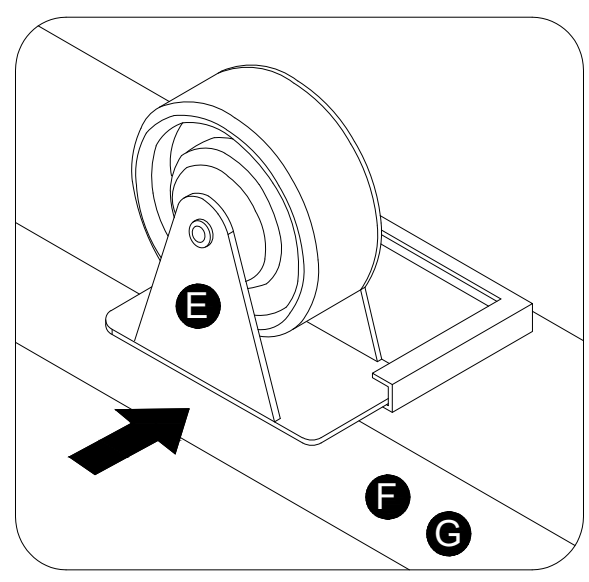
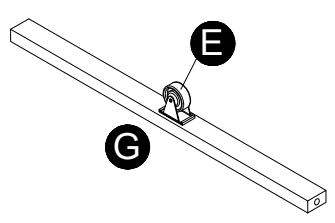

15 **x2**

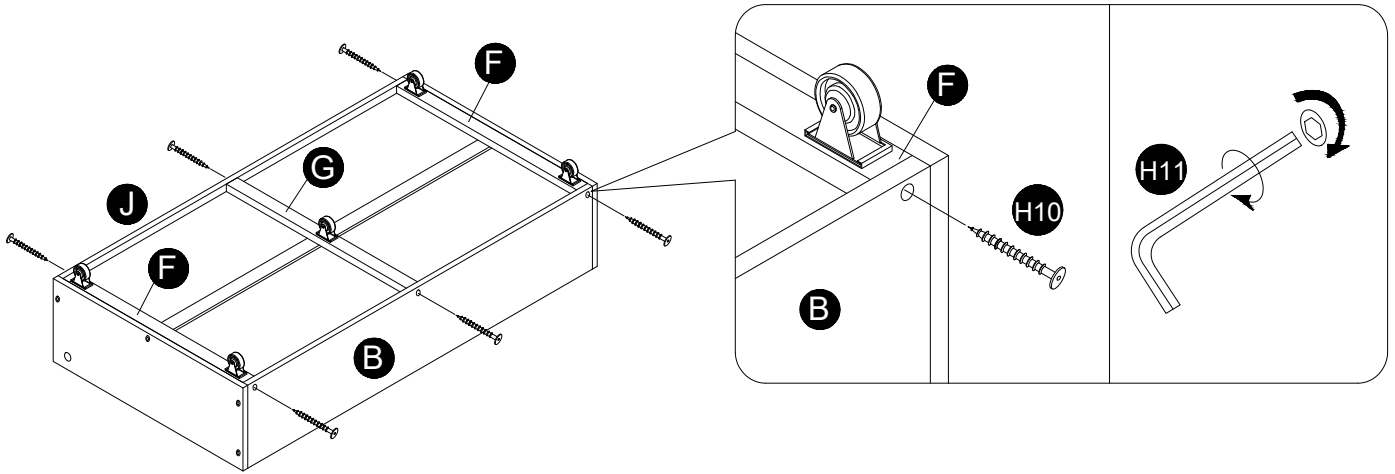

16 **x2**

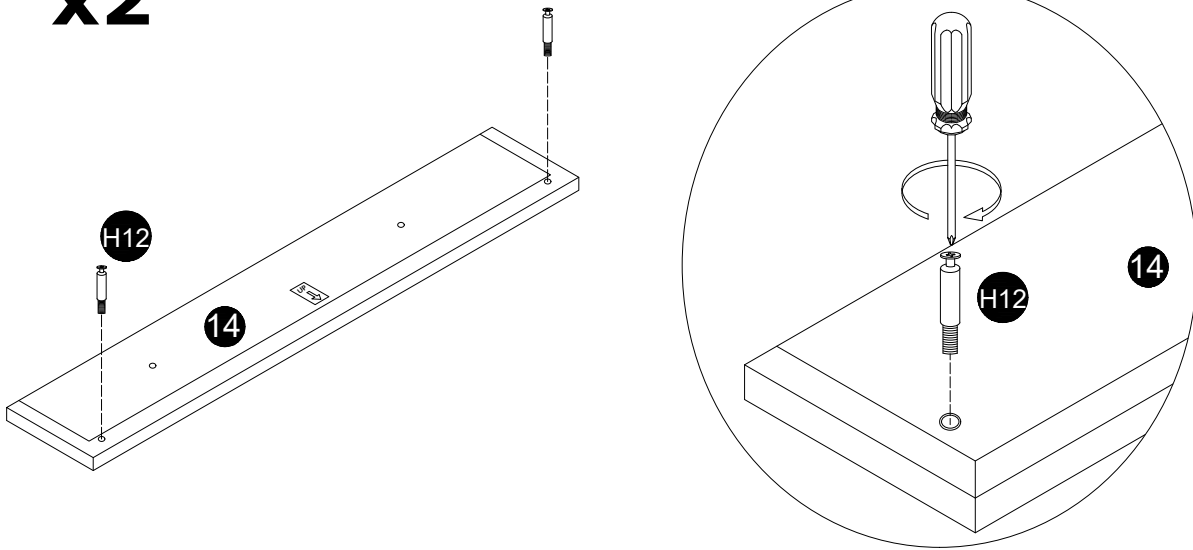

17 **x2**

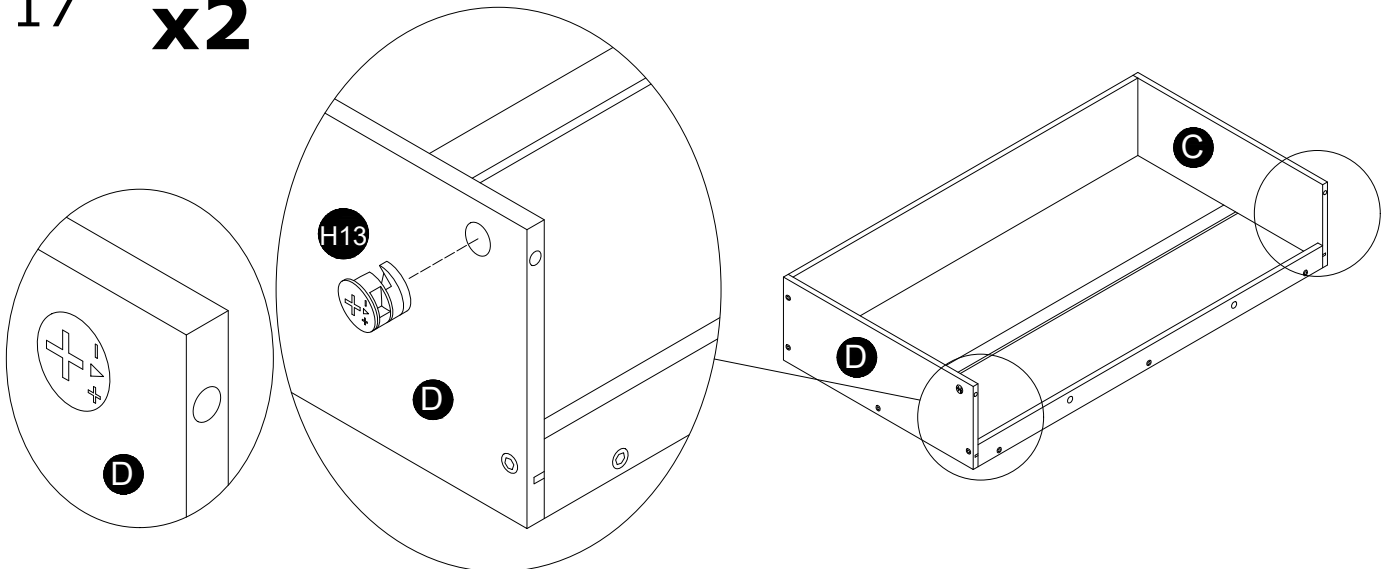

18 **x2**

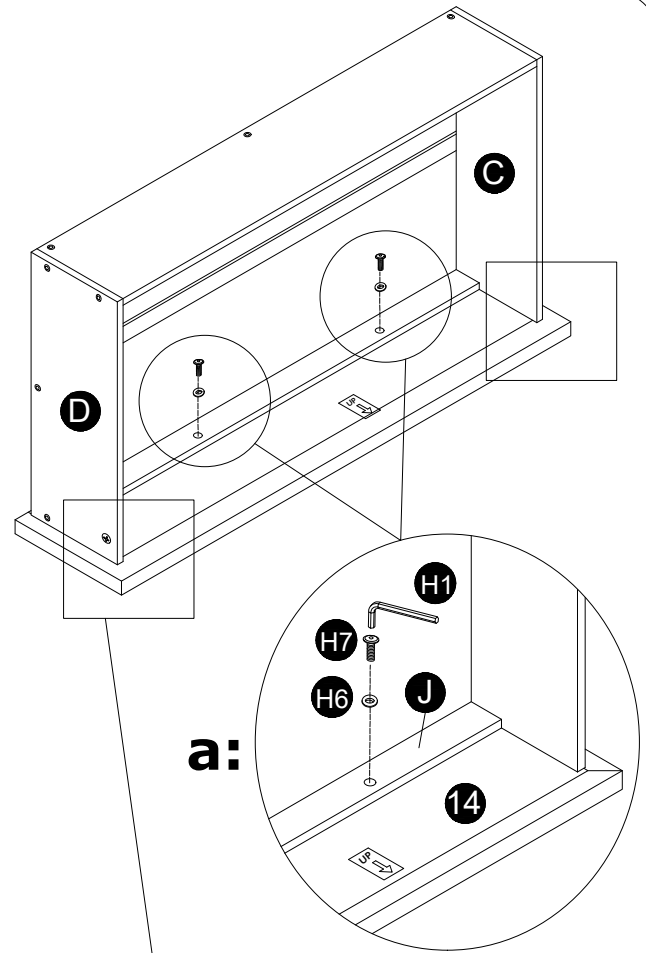
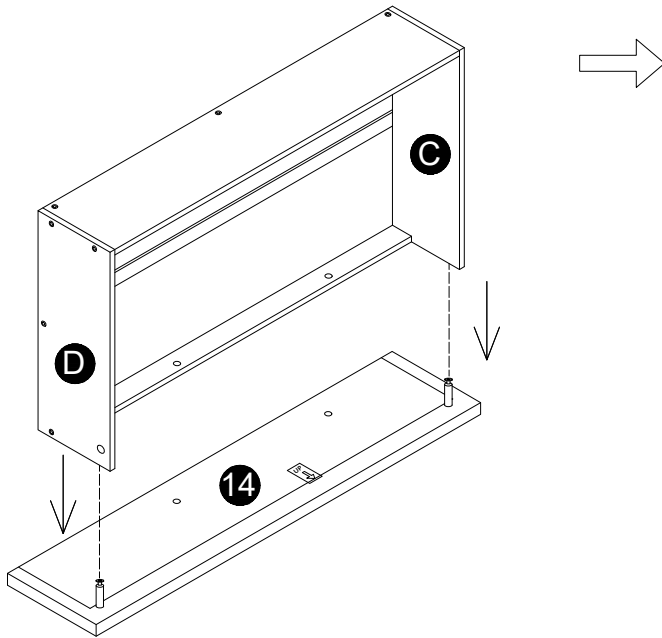

PUSH THE TWO PANELS TOGETHER ALLOWING THE DOWEL TO ALIGN WITH THE HOLE

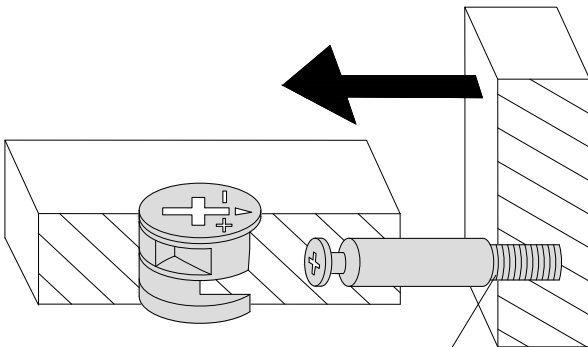

If H12 cannot lock into H13, you can adjust H12 outward by 2mm.

TURN THE CAM IN A CLOCKWISE DIRECTION

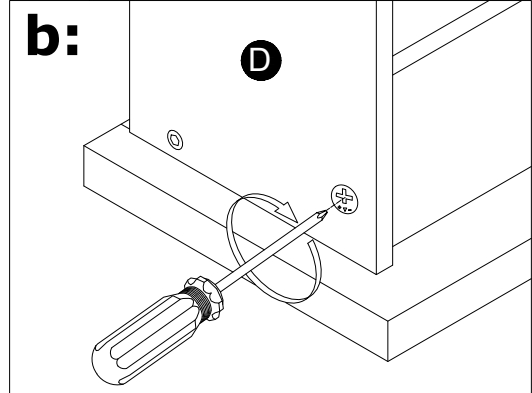
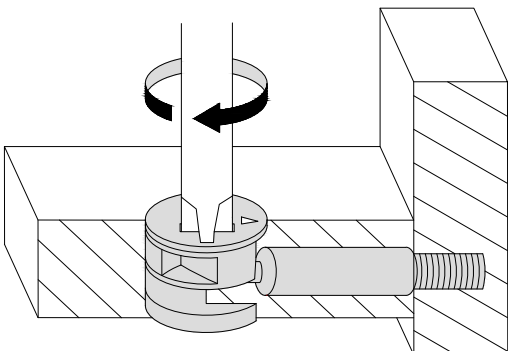

DON'T STOP UNTIL THE 2 O'CLOCK LOCK
TURN THE CAM IN A CLOCKWISE DIRECTION UNTIL THE ARROW POINTS IN THE POSITIONS SHOWN IN THE DIAGRAMS BELOW

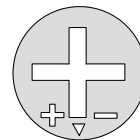

OPEN

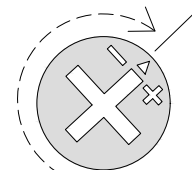

LOCKED

Job Complete !

In the interest of our environment please dispose of all packaging thoughtfully.