

# INSTRUCTION MANUAL ENCLOSED

## ATTENTION

IF YOU HAVE ANY PROBLEMS OR QUESTIONS, EMAIL OR CALL  
CUSTOMER SERVICE BEFORE YOU RETURN THIS PRODUCT TO THE  
STORE WHERE IT WAS PURCHASED.

\*\*When emailing Customer Service, please include your **Order Number** and **platform of purchase** in the email subject for quicker assistance.

# INSTRUCTION MANUAL ENCLOSED





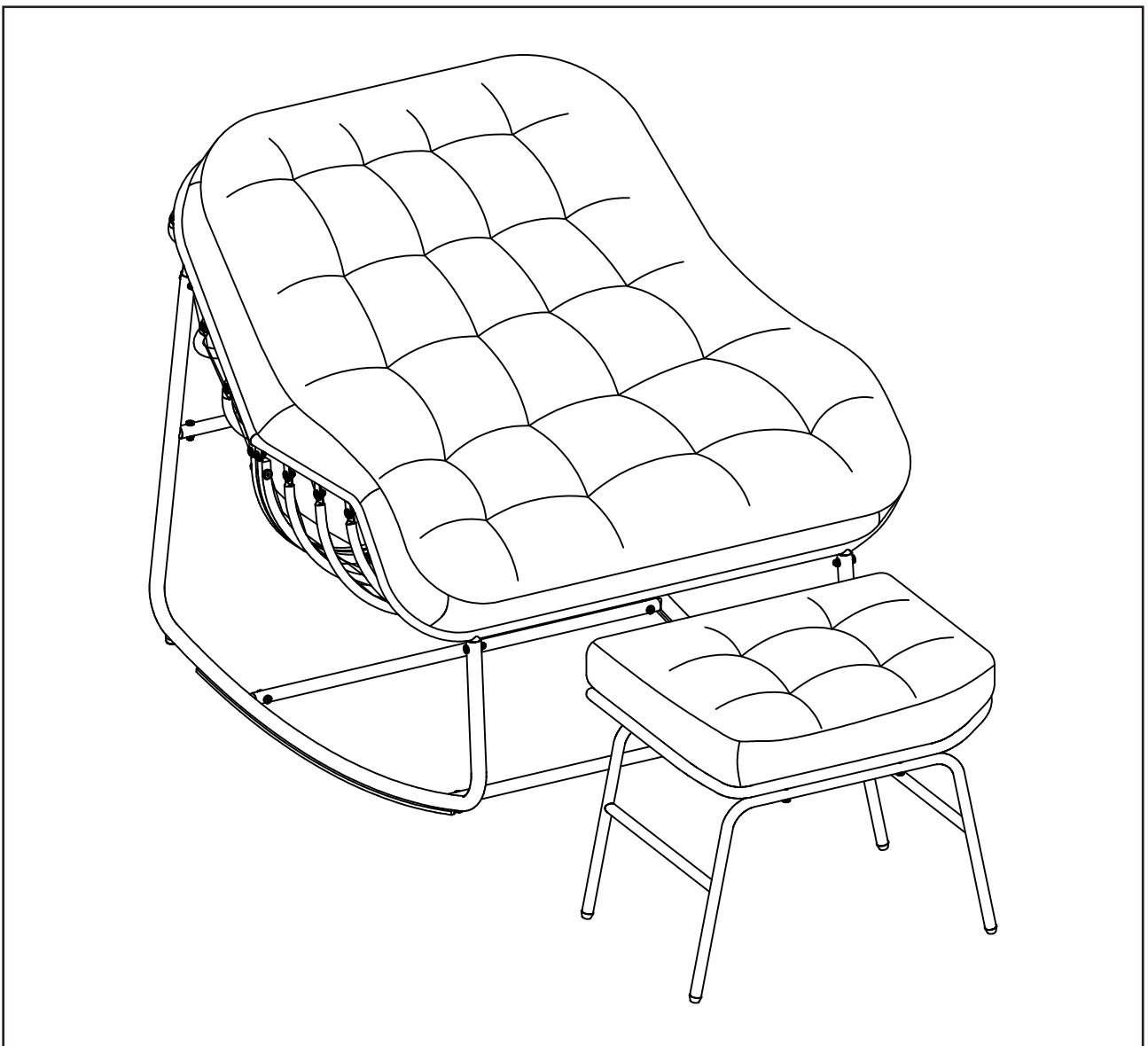





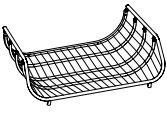

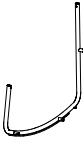
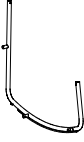
## 2PCS RELAX ROCKING CHAIR

### 2PCS RELAX ROCKING CHAIR ASSEMBLY INSTRUCTION

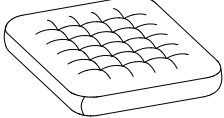
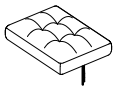
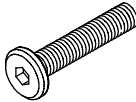
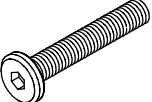
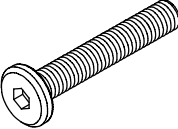
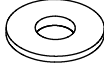
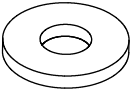

# PARTS LIST

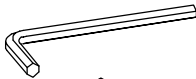
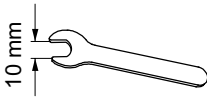
| Part            | Description       | Quantity |
|-----------------|-------------------|----------|
| <b>PARTS</b>    |                   |          |
| 1               | Chair seat        | 1        |
| 2               | Backseat          | 1        |
| 3               | Right leg         | 1        |
| 4               | Left leg          | 1        |
| 5               | Front brace       | 1        |
| 6               | Middle brace      | 1        |
| 7               | Back brace        | 1        |
| 8               | Stool seat        | 1        |
| 9               | Stool leg         | 1        |
| 10              | Chair cushion     | 1        |
| 11              | Stool cushion     | 1        |
| <b>HARDWARE</b> |                   |          |
| A               | Bolt M6x30 mm     | 10       |
| B               | Bolt M6x35 mm     | 4        |
| C               | Bolt M8x50 mm     | 4        |
| D               | Washer Ø6x14x1 mm | 24       |
| E               | Washer Ø8x16x1 mm | 8        |
| F               | Nut M6 mm         | 10       |
| G               | Nut M8 mm         | 4        |
| H               | Allen key 4x98 mm | 3        |
| J               | Wrench 90x10x2 mm | 1        |
| K               | Wrench 90x13x2 mm | 1        |

|    |  |     |   |    |   |    |  |     |  |
|----|--|-----|---|----|---|----|--|-----|--|
| 1  |                           | 2   |              | 3  |              | 4  |             | 5   |                           |
| x1 |  | x1  |   | x1 |   | x1 |  | x1  |  |
| 6  |                           | 7   |              | 8  |              | 9  |             | 10  |                           |
| x1 |  | x1  |   | x1 |   | x1 |  | x1  |  |
| 11 |                           | A   | <br>M6×30 mm | B  | <br>M6×35 mm | C  | <br>M8×50 mm | D   | <br>Ø14×1 mm              |
| x1 |  | x10 |   | x4 |   | x4 |  | x24 |  |
| E  | <br>Ø16×1 mm            | F   | <br>M6 mm  | G  | <br>M8 mm  | H  | <br>4 mm   | J   | <br>10 mm<br>90×25×2 mm |
| x8 |  | x10 |   | x4 |   | x3 |  | x1  |  |
| K  | <br>13 mm<br>90×25×2 mm |     |   |    |   |    |  |     |  |
| x1 |  |     |   |    |   |    |  |     |  |

## PLEASE READ AND FOLLOW ALL SAFETY TIPS

### GETTING STARTED

1. Before assembly, CAREFULLY use scissors or utility knife to cut and unwrap all parts. Make sure you do not discard the hardware.
2. Make sure that you have all the parts listed. If you are missing any parts, please email us. Please identify the parts you need and model number. Make sure to include your name and address.
3. Please include your **Order Number** and **platform of purchase** in the email subject, and one of our customer service representative will get back to you.

### Warm Tips:

1. The plastic covers on some metal parts are just for product protection. Please remove it before assembly.
2. Please follow the sequence of AI during assembly.
3. Do not tighten the screws until all of them are in right positions.

1. Locate the chair seat (1) to the backrest (2) by the pre-drilled threads. (Photo 1).

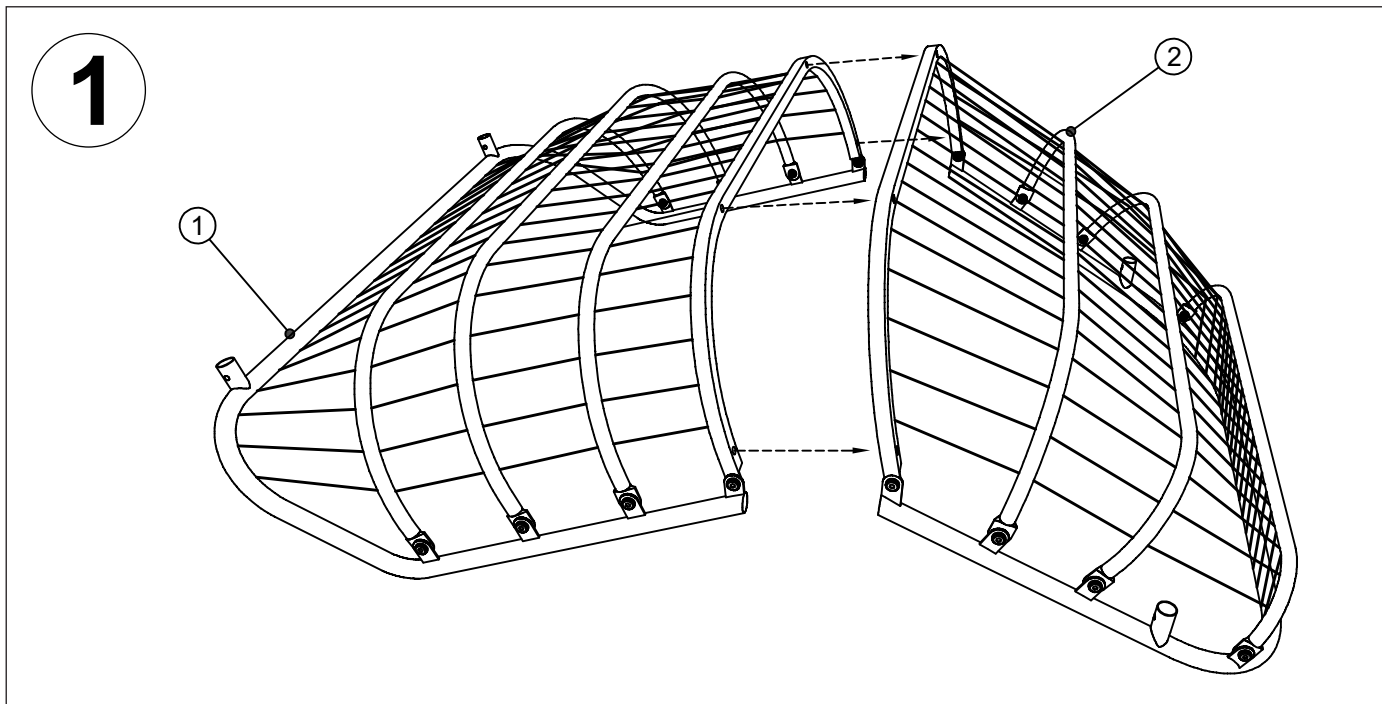

2. Use Allen Key (H) to tighten Bolts (C) and Washers (E), Nuts (G) and Wrench (K).  
Note: only tighten 80% (Photo 2).

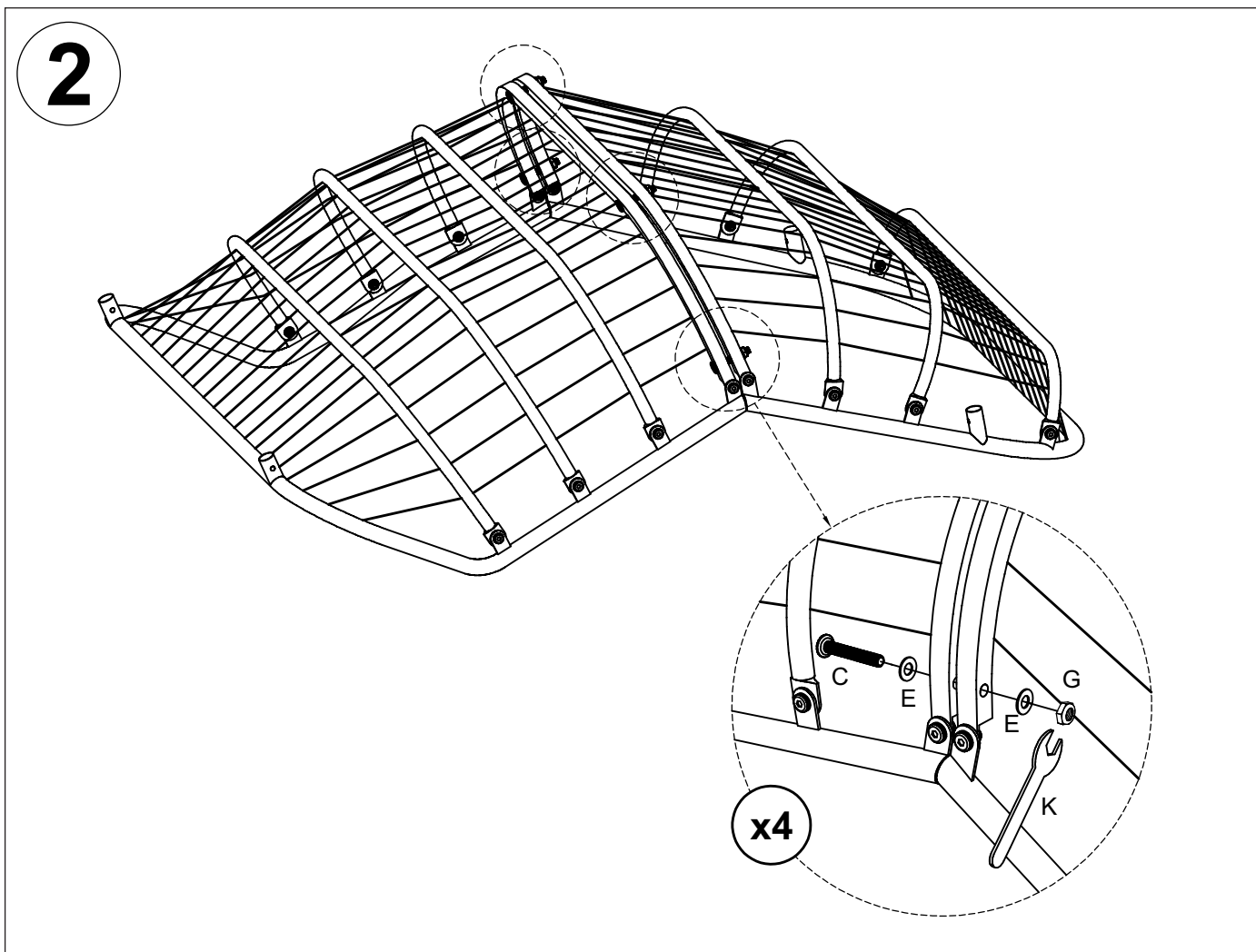

3. Locate the front brace (5), middle brace (6), back brace to the right leg (3) and left leg (4) by the pre-drilled threads (Photo 3).

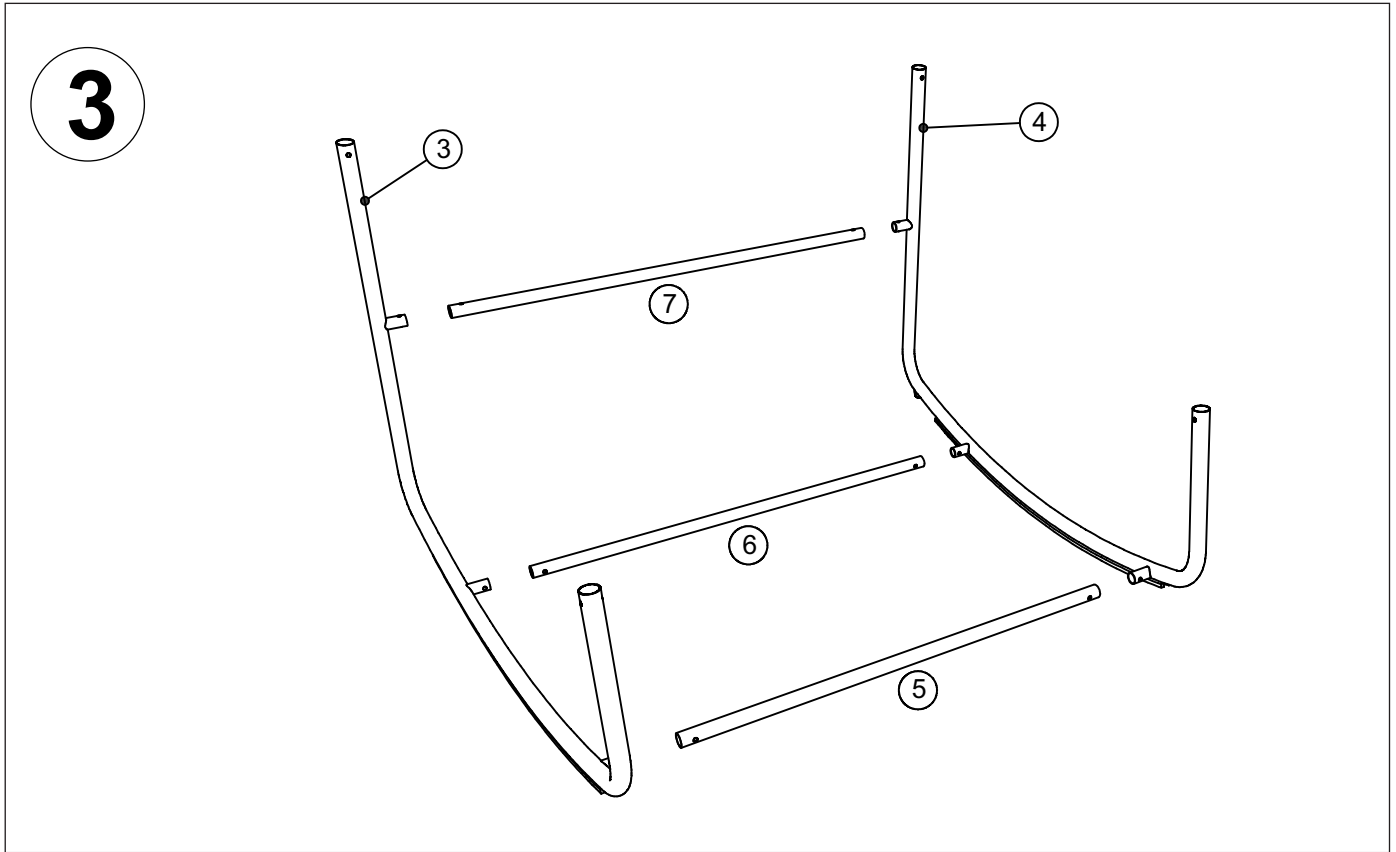

4. Use Allen Key (H) to tighten Bolts (A), Washers (D), Nuts (F) and Wrench (J) .  
Note: only tighten 80% (Photo 4).

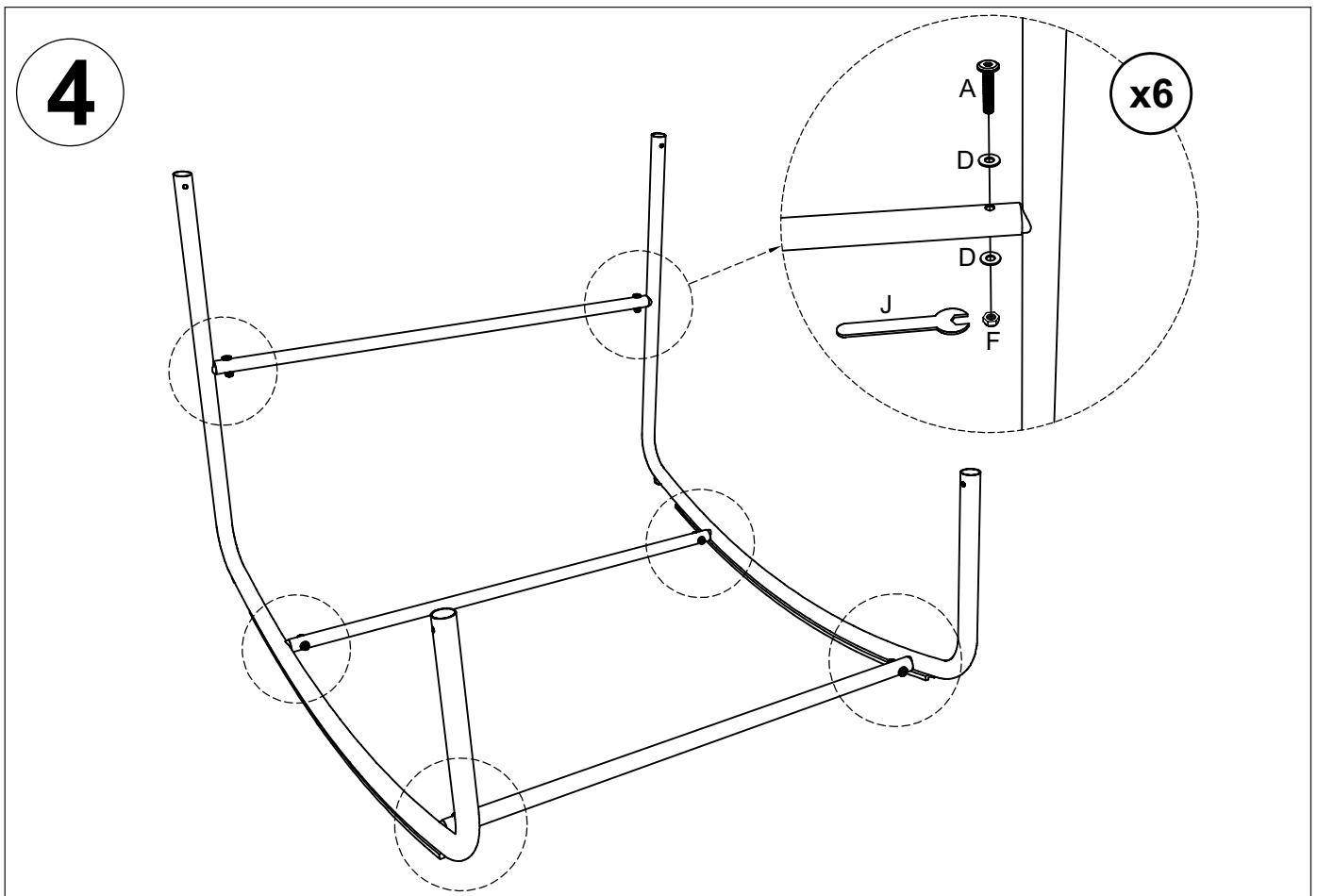

5. Locate the right leg (3) and left leg (4) to the chair seat (1), backrest (2) by the pre-drilled threads. (Photo 5).

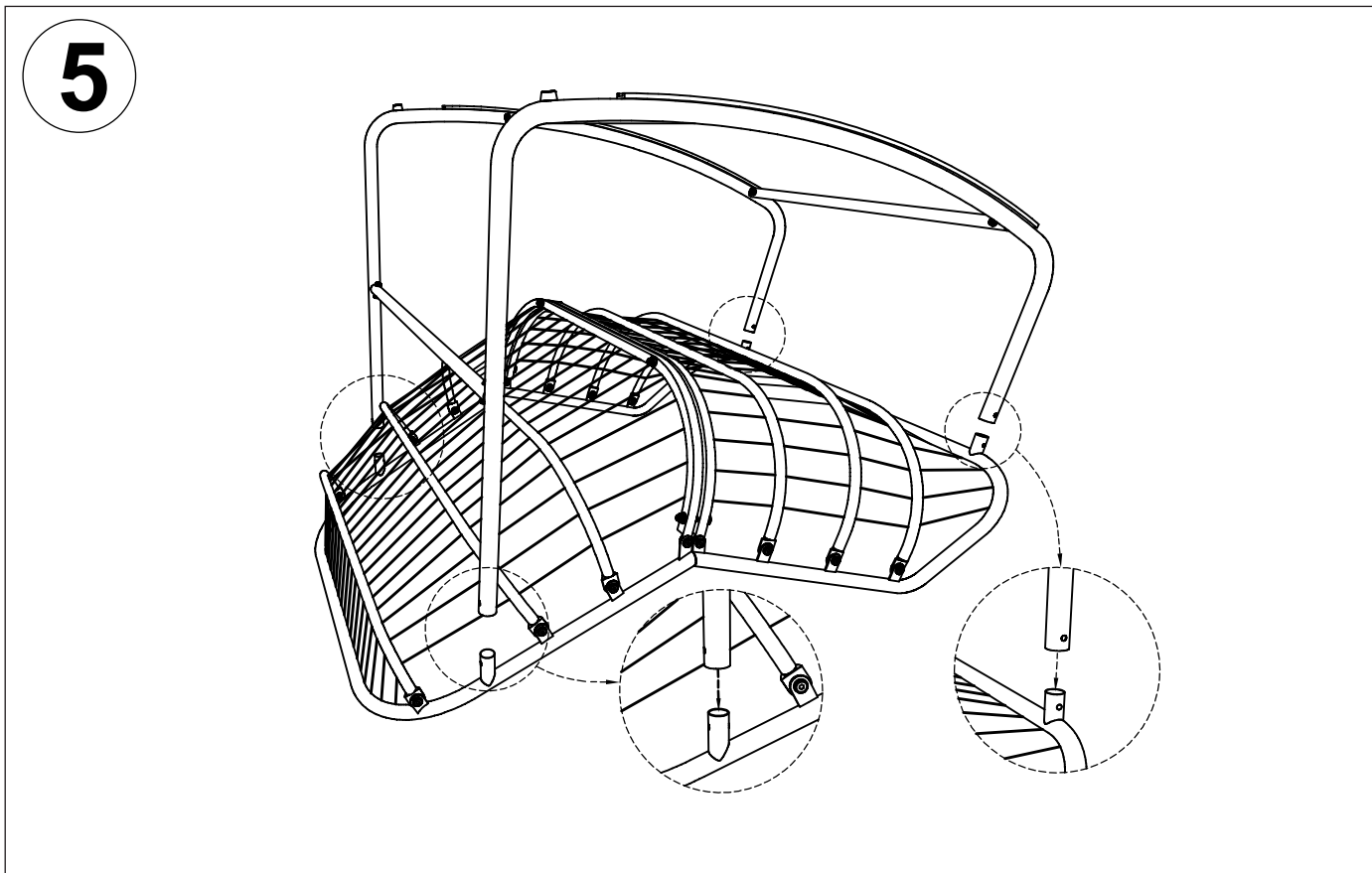

6. Use Allen Key (H) to tighten Bolts (B), Washers (D), Nuts (F) and Wrench (J). Note: only tighten 80% (Photo 6).

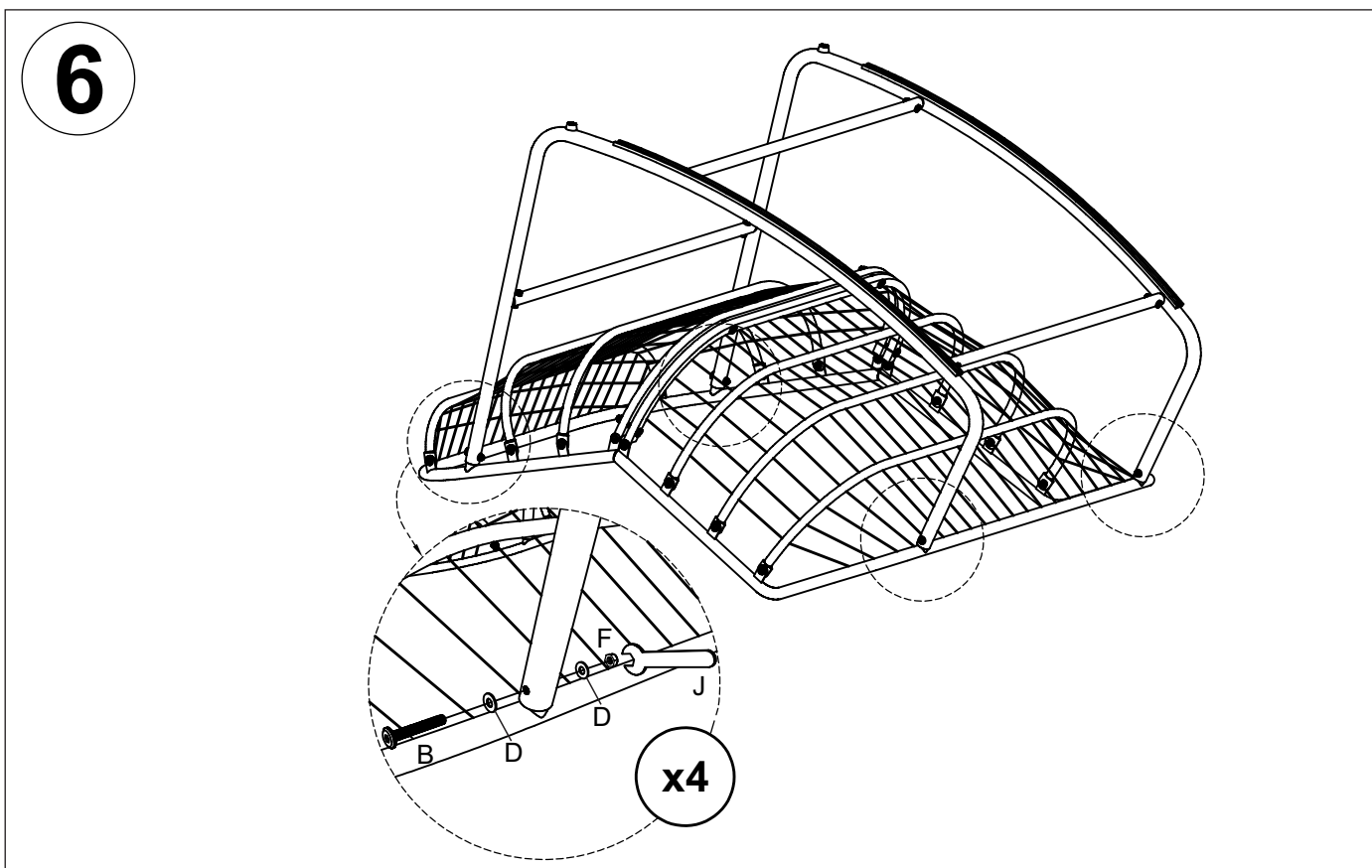

7. Use Allen Key (H) to tighten all Bolts 100%  
Place chair cushion (10) on the top chair seat (Photo 7).



8. Tie the chair cushion's cord to secure it as shown in the picture. (Photo 8).

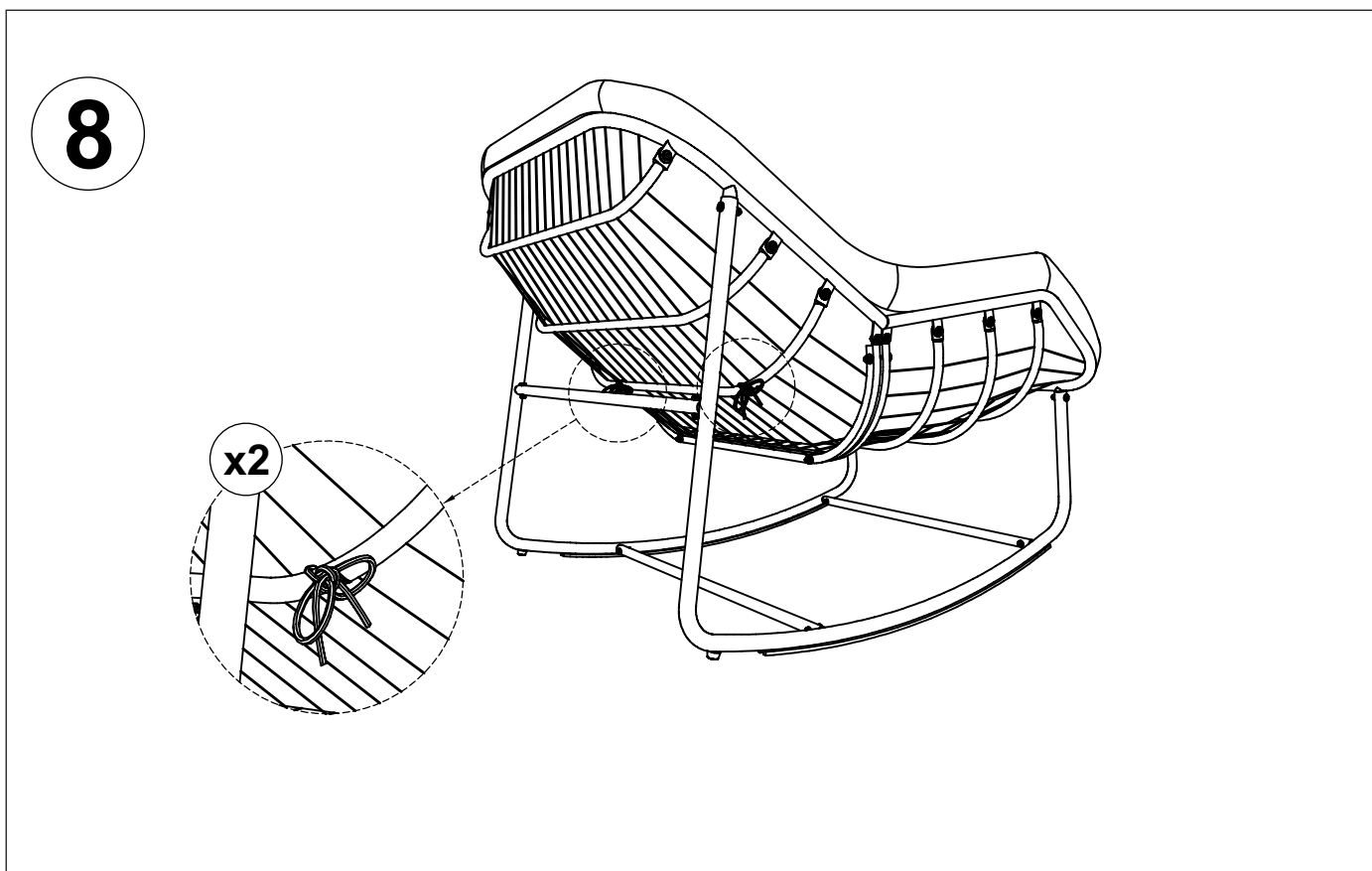

9. Locate stool leg (9) to the stool seat (8) by the pre-drilled threads.  
Use Allen Key (H) to tighten Bolts (A) and Washers (D).  
Note: only tighten 80% (Photo 9).

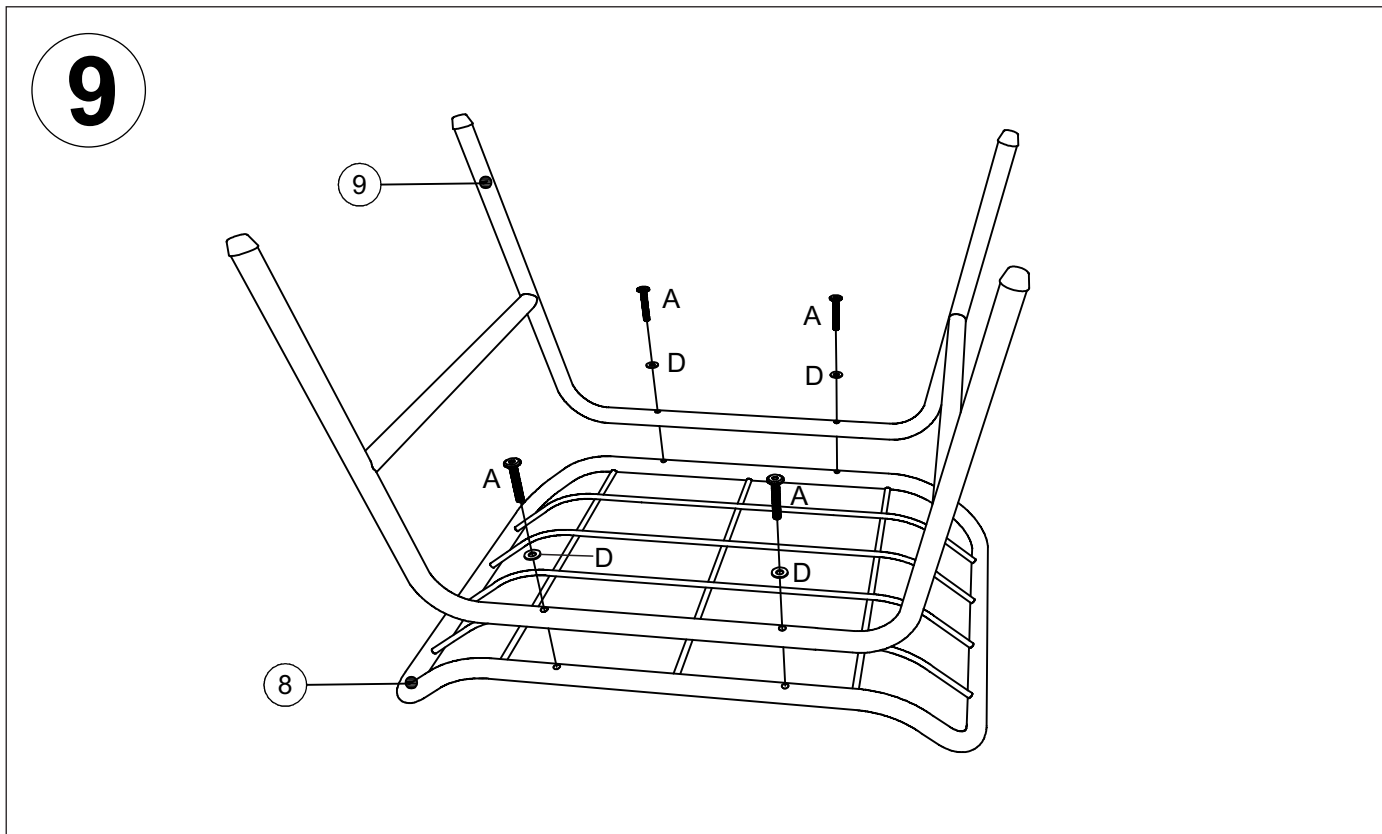

10. Use Allen Key (H) to tighten all Bolts 100%  
Place the stool cushion (11) on the top stool seat and tie the string to secure it as shown in the picture (Photo 10).

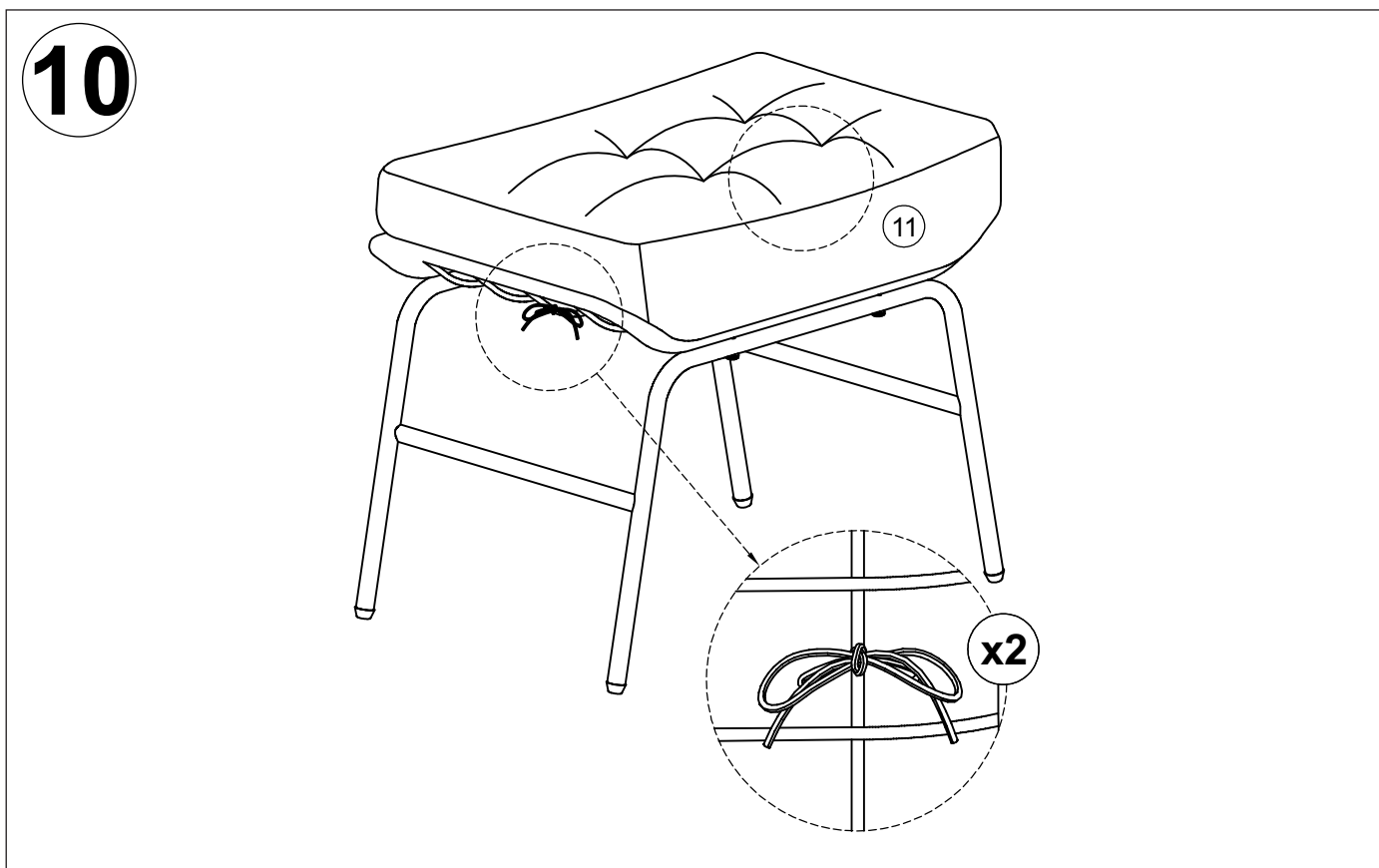

**Till now you have finished the whole assembly and enjoy your furniture!**