

# Assembly Instructions

**Caution : You must read this before you proceed**

## Care & Maintenance



- ⊘  ● Not for commercial use. For residential use only.
- ✓  ● Furniture may scratch floors. We recommend using furniture pads to protect your floors.
- ⊘  ● Do not put hot items directly on furniture surface.
- ⊘  ● Do not clean furniture with harsh cleansers or polish.
- ⊘  ● Do not place furniture under direct sunlight.
- ⊘  ● Do not place furniture near heating or cooling vents.
- ⊘  ● Do not write on furniture without a padded barrier to protect the surface.
- ⊘  ● Do not place furniture outside . For indoor use only.
- ⊘  ● Stains may be removed with mild soap solution and damp cloth.
- ⊘  ● Children should not climb or jump on the furniture.
- ✓  ● Dust and pick-up spills using a clean, non-colored, lint-free cloth.

Please look in small carton for hardware packs and legs.  
Sets often ship in multiple boxes and may arrive a day or two apart.

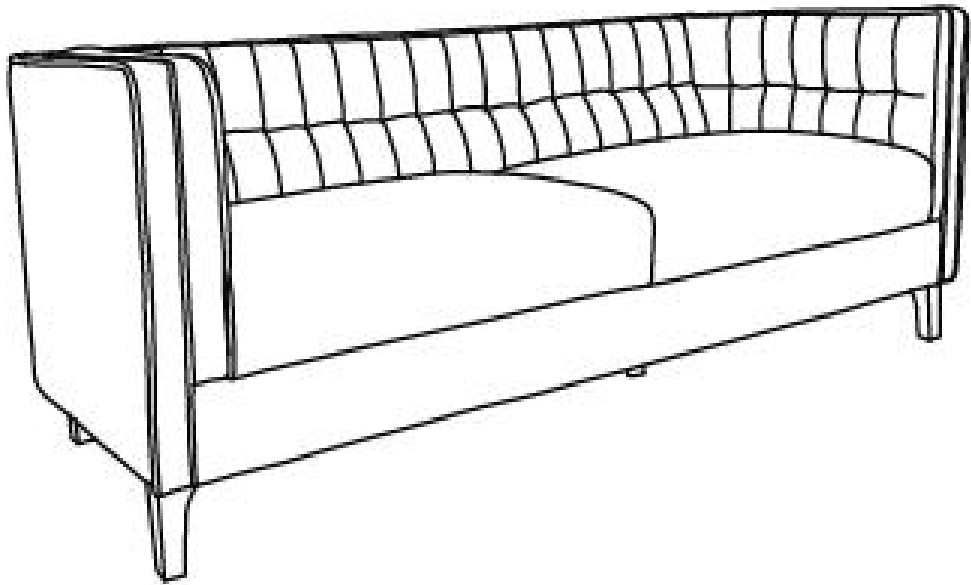



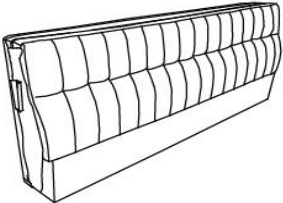
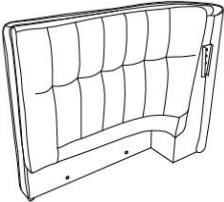
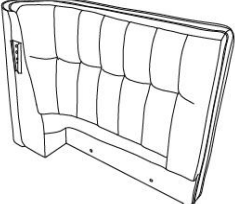
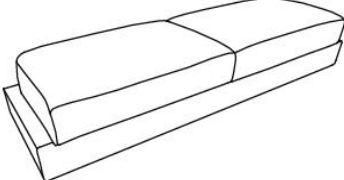

# SOFA



# Parts List

Label	Picture	Description	QTY
A		Backrest	1
B		Left Armrest	1
C		Right Armrest	1
D		Seat	1
E		Leg	4
F		Middle Support Leg	1
	A*1, D*1, E*4, F*1,Hardwares*1		
	B*1, C*1		

# Hardwares

Label	Picture	Description	QTY
①		Bolt (M8*70 MM)	11
②		Washer(M8)	11
③		Spring Washer(M8)	11
④		Allen Wrench(M8)	1
⑤		Gasket	8
⑥		Silicon Gasket	7

## Assembly Preparation

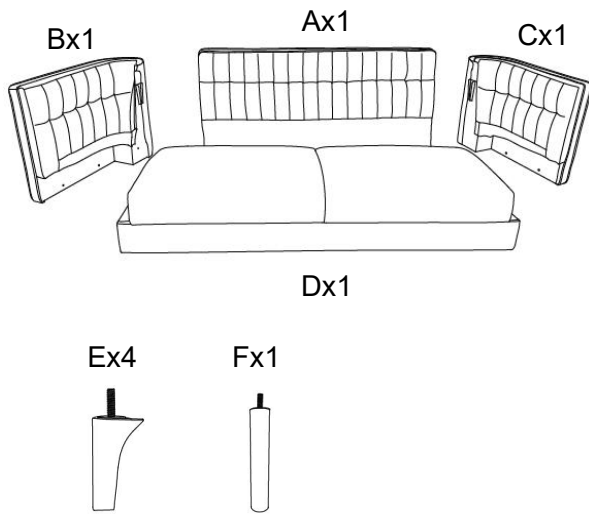
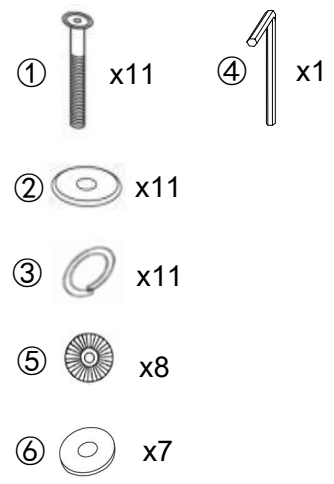
<p>Before Begining Assembly:</p>		
--	---	---



- Read instructions, cover to cover-



- Have 2 adults on hand for assembly-



- Do not assemble on flooring or carpet-



- Assemble on a clean non-marring surface (packing foam)-



- Save all packaging until finished-

# Assembly Steps

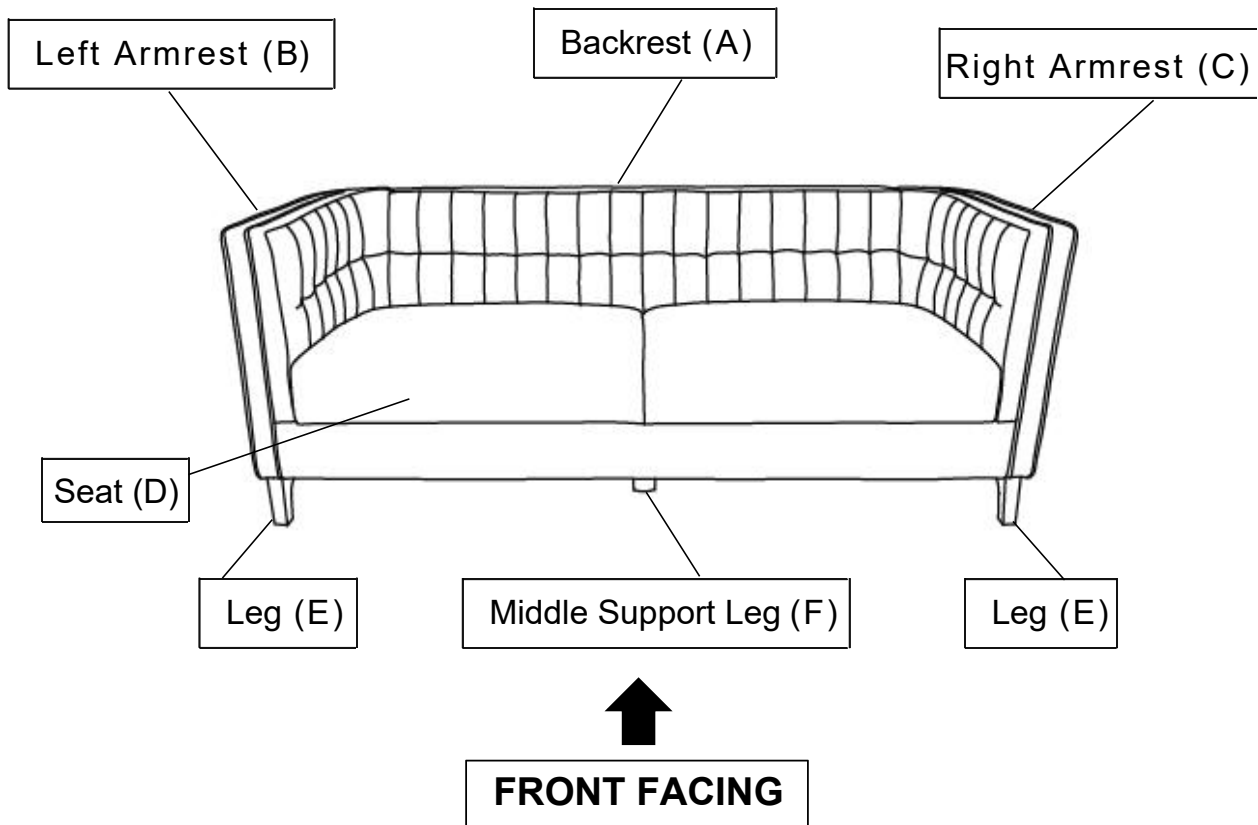

This Sofa has multiple parts and may require up to 30 minutes to assemble.

To give you an overview of the Sofa parts, the above picture is to help you put the various parts into perspective.

Please read through the instructions below to familiarise yourself with the parts and steps before assembly.

Note: It is recommended that you have an adult partner to assist during the entire assembly process.

## Step 1

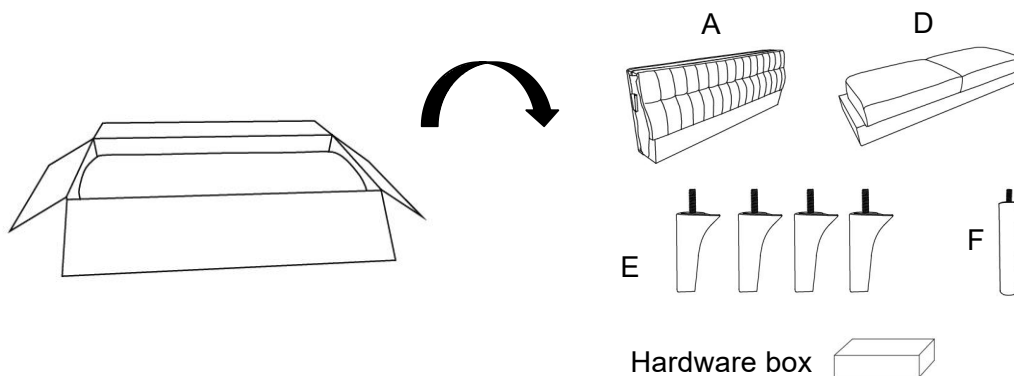

Take out the Backrest(A), Seat(D), Leg(E), Middle Support Leg (F) and Hardware box from the Carton "A", place it on a clean, non-marring surface.

## Step 2

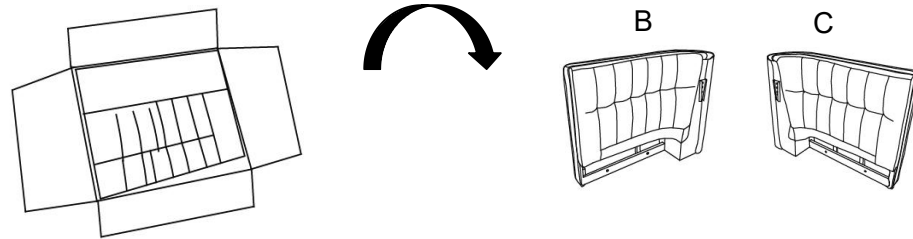

Take out the Left Armrest(B), Right Armrest© from the carton "B" and place them on a clean, non-marring surface.

## Step 3

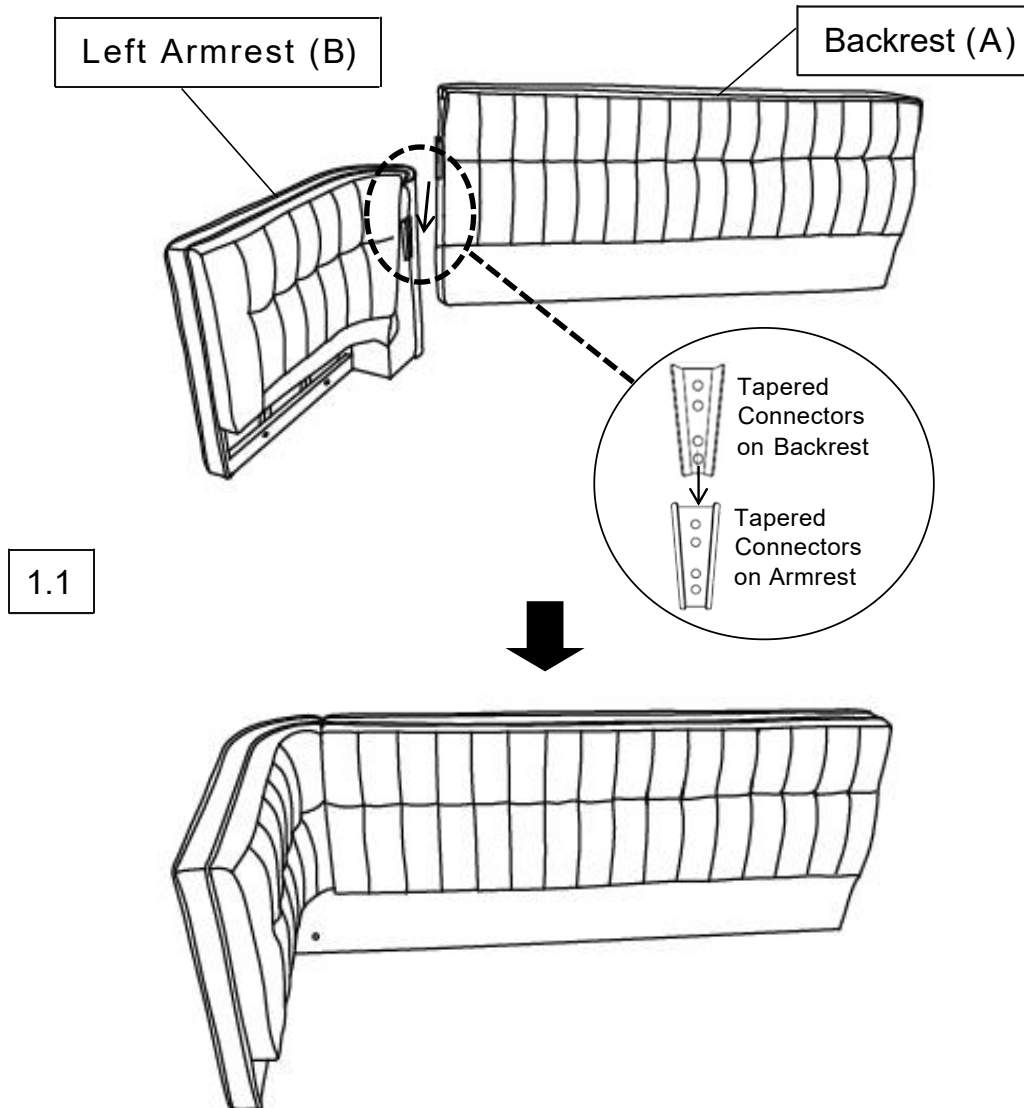

With the assistance from your adult partner:

1.1) Lift the Backrest(A) up, make sure the Backrest(A) is vertical and aligned to the Left Armrests(B).

Your adult partner may need to push the Armrests in towards the Backrest(A) to allow for better alignment.

Slip and Slide the Left Armrests(B), in a gradual and balanced manner into the Tapered Connectors.

Push the Backrest(A) downwards until it is fully slotted and locked into position.

## Step 4

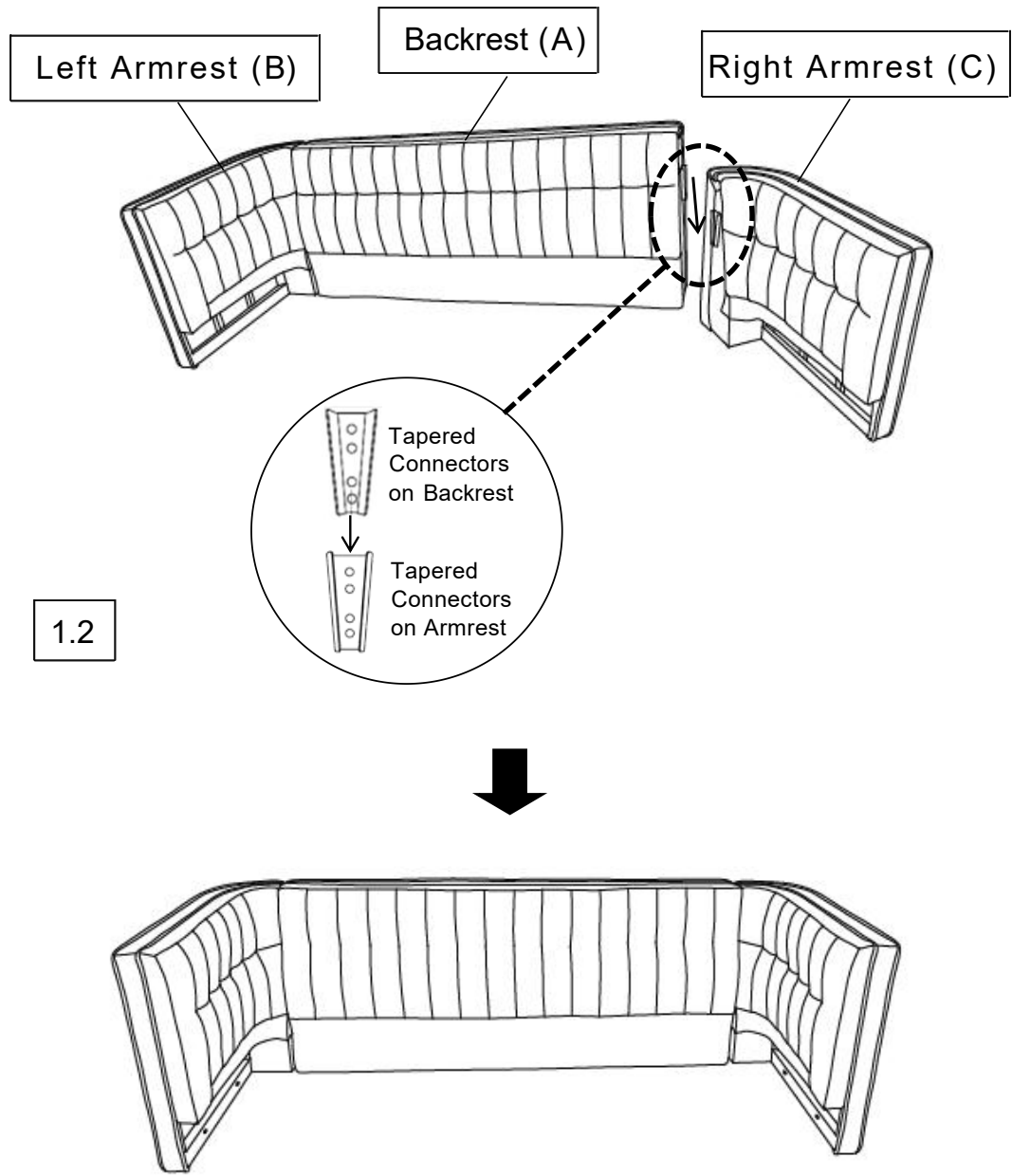

1.2) Installation of the right armrest(C) follows the steps of 1.1).

**Note: Make sure the Tapered Connectors on the Backrest(A) lock into the Tapered Connectors on Armrest(B&C) .**

**Fully locked position: Check and assess that the base of the Backrest(A) and Armrest(B&C) are aligned and level.**

## Step 5

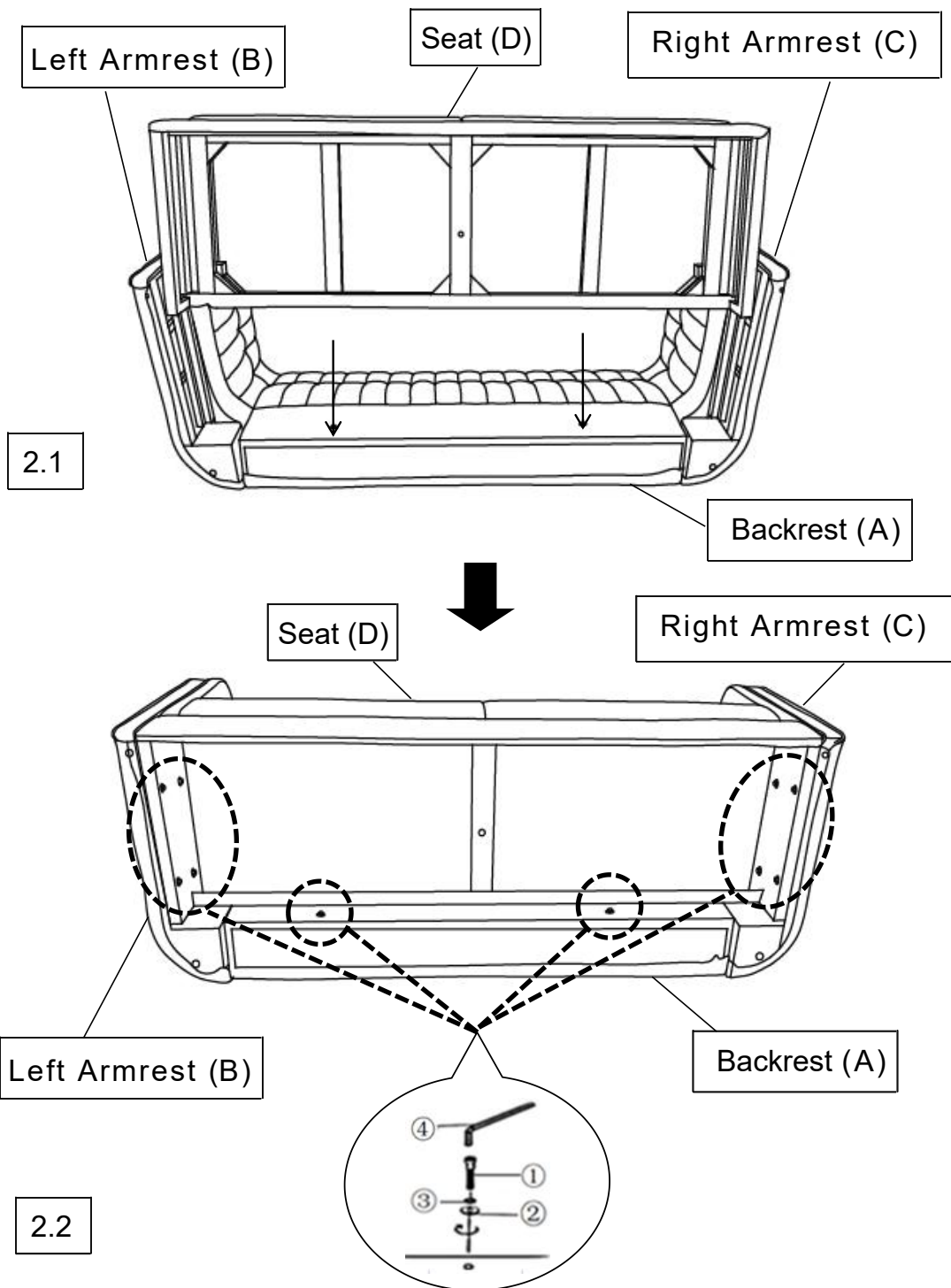

With the assistance from your partner.

2.1) Shown as above picture, Tilt and lay the STEP4 assembled parts on its Backrest(A) onto a flat surface.

2.2) Attach the Seat(D) to the Left Armrest(B) & the Right Armrest(C) & Backrest(A) using Bolts (①), Spring Washers(③), and Washers(②) with the Allen Wrench(④).

**DO NOT fully tighten a Bolt in one go and then move on to the next.**

**Rather, In a sequential manner, gradually tighten each Bolt until all Bolts are evenly secured.**

**This methodology will ensure maximum evenness once all Bolts are fully tightened.**

**Note: Insert the bolts on the Armrest first, then go to Backrest. If you can not insert the Bolt into position on Backrest, please push the Backrest towards Seat bottom, make sure the Backrest bottom is leveling with Seat bottom.**

## Step 6

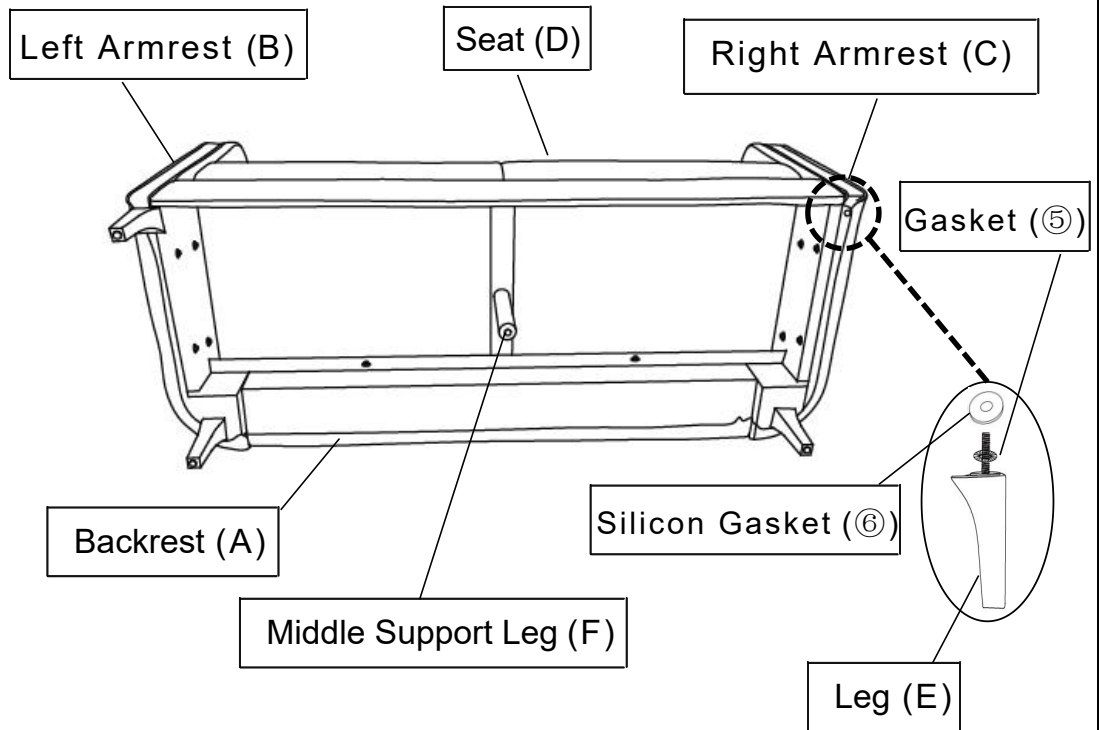

Install the Sofa Leg(E) and the Middle Support Leg(F) onto the bottom of the Sofa by placing one Gasket(5) and one Silicon Gasket (6) on the threaded stem.

Then insert the threaded stem into the threaded mounting position at the corner of the Sofa.

Tighten by turning the Leg clockwise.

Repeat the same step to install the remaining Legs.

**Note: The use of Gaskets are OPTIONAL and are especially useful to help alleviate slight wobbles.**

**Some Legs may need more than one whilst some legs may not need any.**

## Step 7

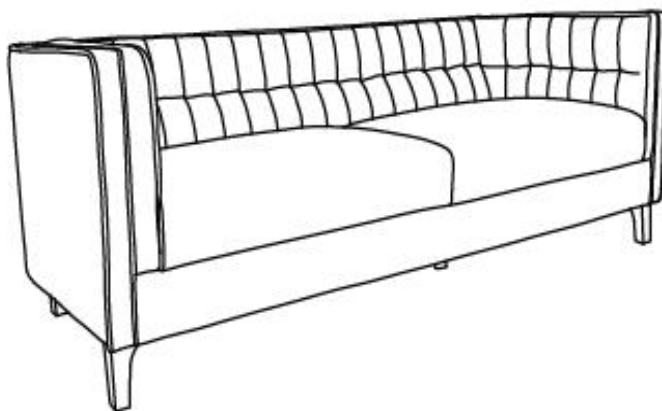

Your Sofa is ready for use.

This Sofa can only be used on a flat, level surface.