

Electrically adjustable office desk with leg lifts

User Manual

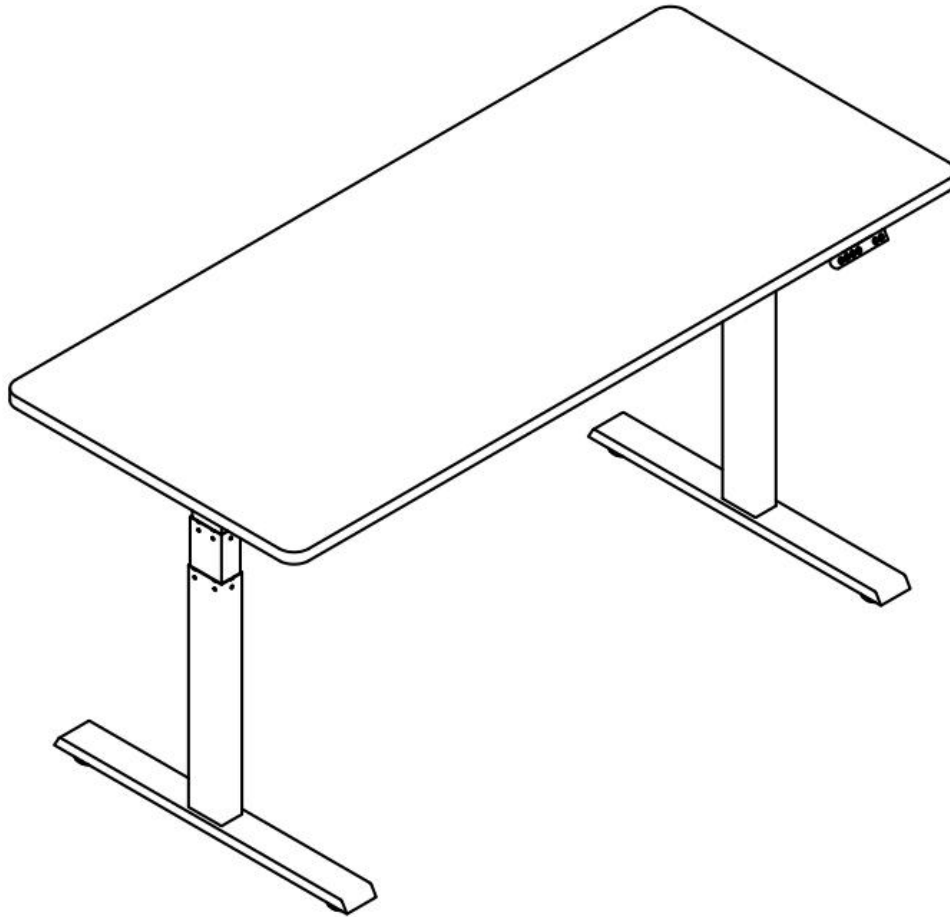

Attentio

Ensure smooth desk mobility with appropriate cable lengths. Improper use may cause significant property damage and personal injury. Always follow the user manual.

keynote

Any user or before installing the desktop, must carefully study this manual.

Table of Contents	Page
1. Security Notice	2
2. Use	2
3. Setup and Installation	2
4. Part List	3
5. Assembly Instruction Manual	4
6. Controller Setup and Troubleshooting	6
7. Technical Parameters	7
8. Precautions and Warranty Scope	7

1. Safety Notice

- Improper use of this product may result in property damage or personal injury.
- Before using the table, inspect the surroundings. If there are immovable obstacles within the table's movement range, it may result in restrictions on bodily and property rights, leading to harm.
- Ensure the power cord length. When operating the table, the monitor, computer, speakers, and other items connected to electrical wires may be pulled down or severed.
- Please provide the user manual to users, installers, and individuals operating this product.

2. Use

The lifting table is equipped with a DC brushed motor, designed for dry working areas. The table height is adjustable to achieve an ergonomic positioning at the most suitable level. The table must not be used in humid or high-humidity environments.

Do not exercise near the table, lie under the table, or crawl beneath it. Avoid sitting or standing on the table.

Children must not use this product without adult supervision.

3. Setup and Installation

Once the assembly is complete, adjust the table legs to level the tabletop, and the table cannot be moved. Then connect to a 110V or 220V power source for use.

Check for any obstructions in the electrical wiring.

Select a table positioned at a safe distance from windows and living areas to prevent people from getting trapped under it.

Do not place items higher than 50 cm under the table.

After assembly, do not move the table by lifting its tabletop when relocating it.

When lifting the table, reinforce the connection between the table frame and the tabletop.

Lower the table height to easily grasp the frame or remove the tabletop.

4. Part List

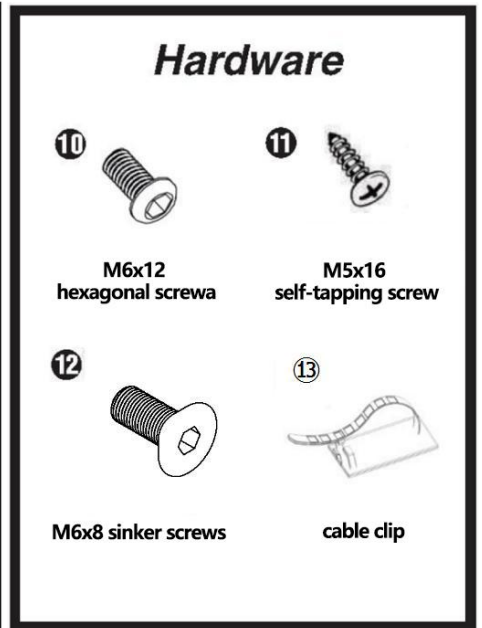
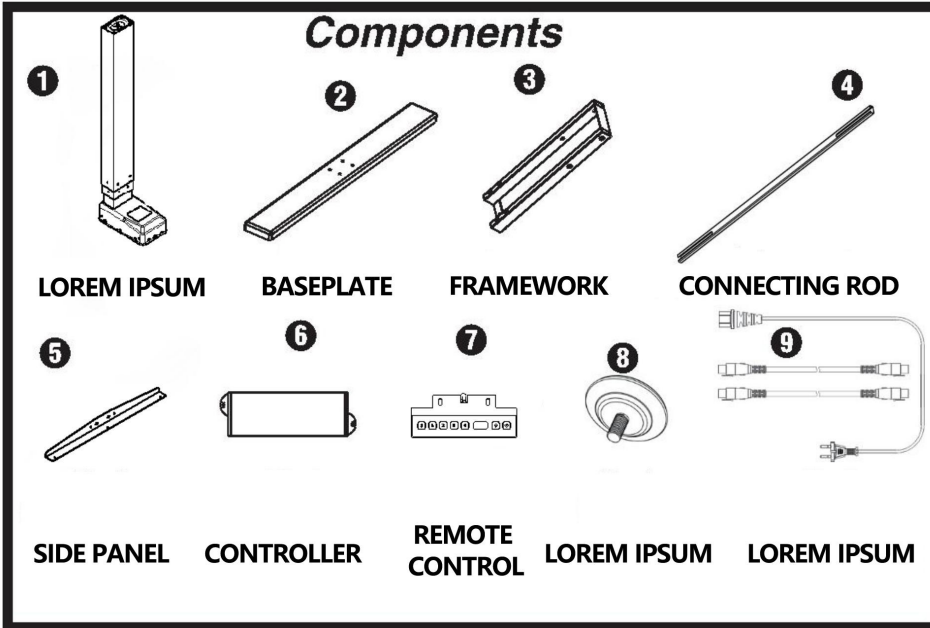
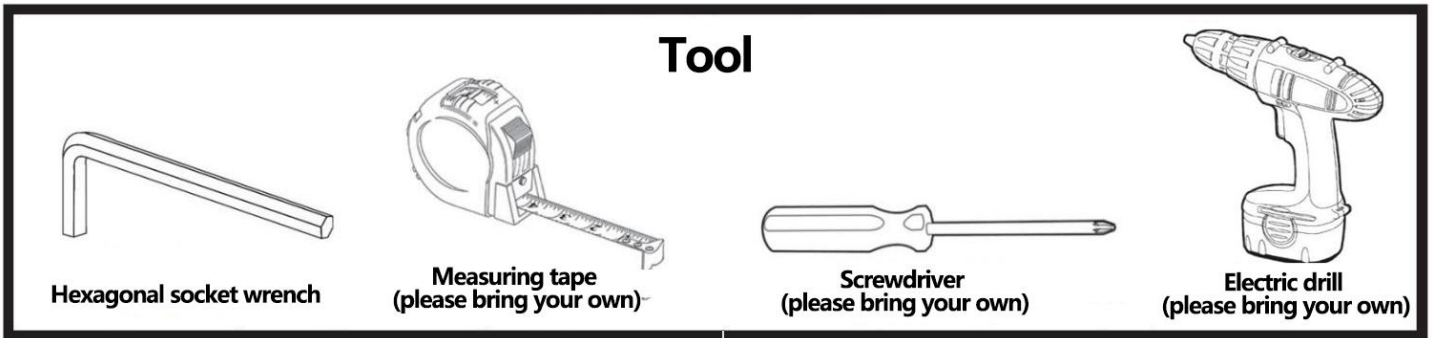

Before handling cardboard boxes and packaging materials, conduct a thorough inventory of all accessories. Use soft padding or carpets at the assembly area to prevent damage. For convenience and safety, it is recommended that two people assemble it.

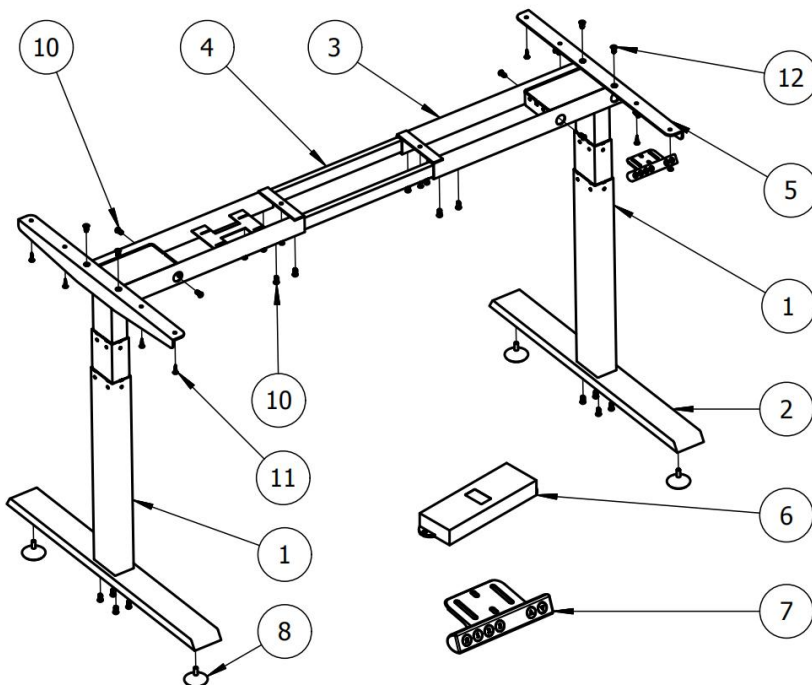

Code name	Name	Quantity
1	Column	2
2	Baseplate	2
3	Framework	2
4	Connecting rod	2
5	Side panel	2
6	Controller	1
7	Remote control	1
8	Wheels	4
9	Power cord	1
10	M6x12 hexagonal screw	24
11	M5x16 self-tapping screw	14
12	M6x8 sinker screws	4
13	Wire clasp	5

5. Assembly Instruction Manual

1. Take out the column (coded as 1) and frame (coded as 3) shown below, then secure them with M6X12 hex-head screws.

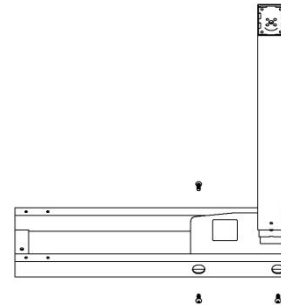
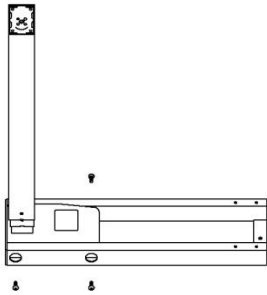

A. Take out two connecting rods numbered 4 as shown in the figure, insert them between rods 3, and note that the two connecting rods have openings facing inward when inserted.

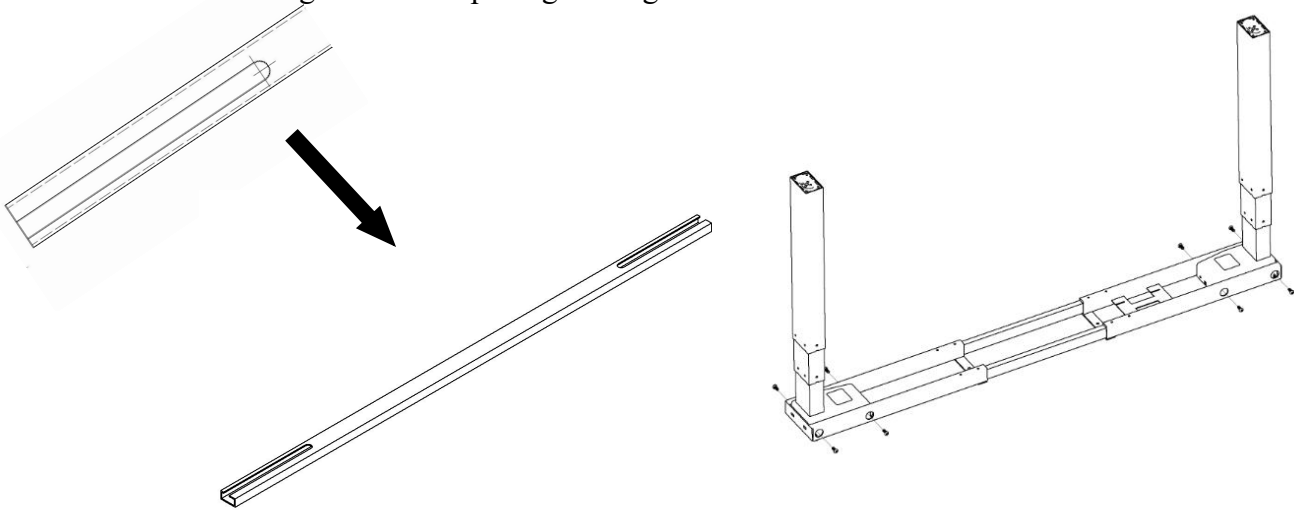

B. Install side panels on both sides of Frame No.3, with each panel secured using two M6x8 countersunk screws.

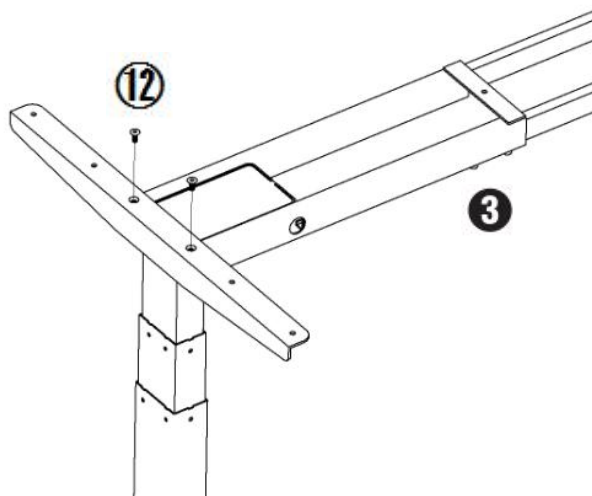

C. According to the direction of the arrow, stretch the length. The length can be determined based on the tabletop. Secure the assembly using M6x12 hex screws.

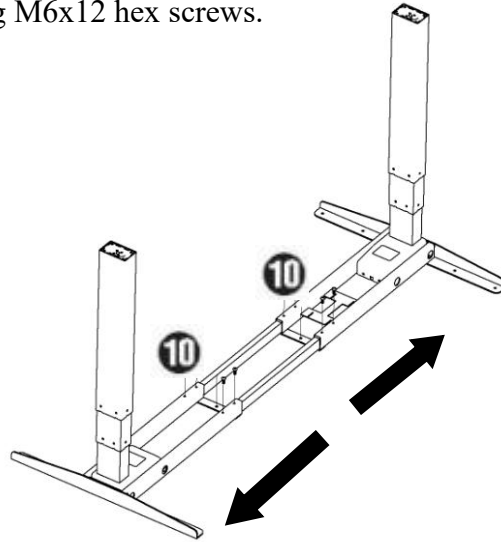

D. Installs No. 2 anchor bolts on 2 No. 1 single columns. As shown in the figure below, tighten the casters and use M6x12 hexagonal screws to attach them.

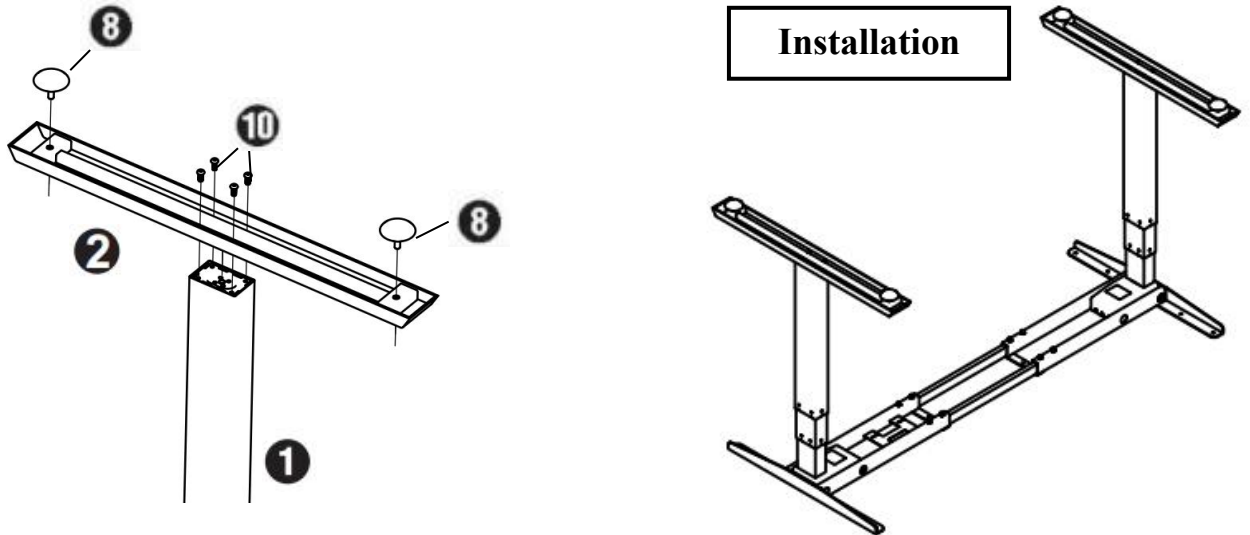

E. Install the tabletop panel, hand controller, and controller. The controller is secured to the tabletop panel using M5x16 cross self-tapping screws or inserted into the frame slot, while the hand controller is attached to the tabletop with M5x16 self-tapping screws.

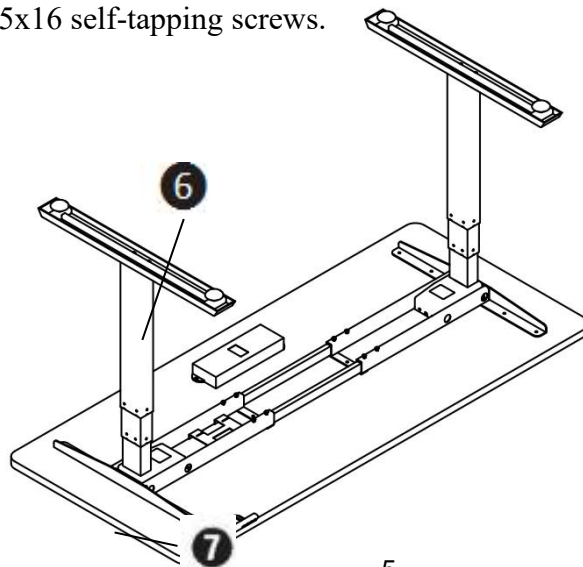

F. Connect the wires as shown in the diagram below, Use wire clips to fix the connecting wires, so that the wires do not sag.

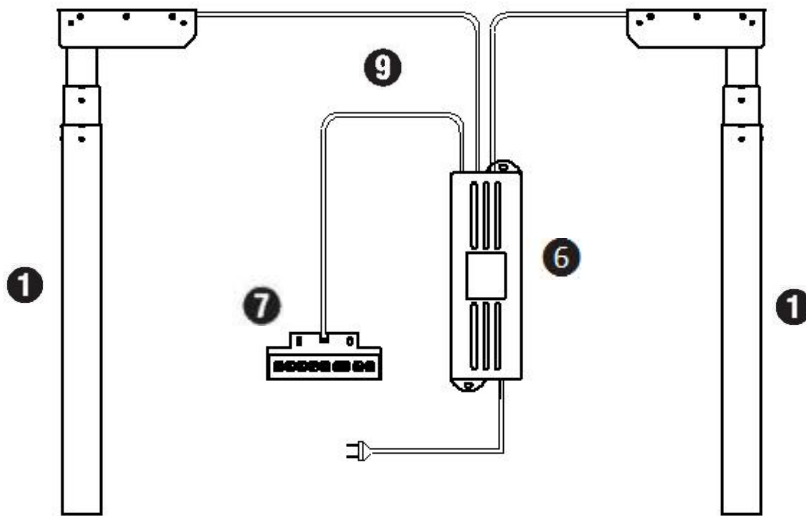

6. Controller Setup and Troubleshooting

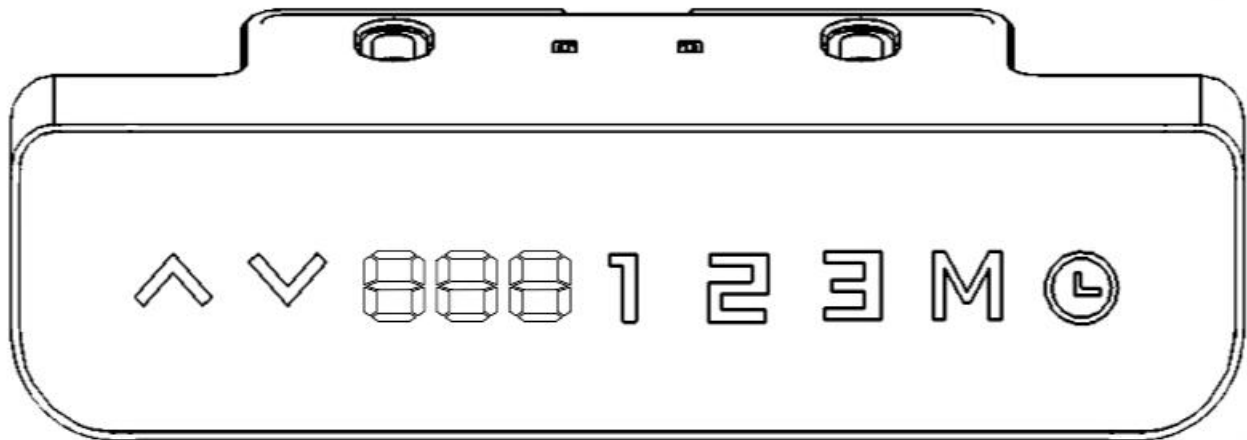

I. Table height adjustment

Press and hold the ▲ or ▼ key to control the lifting table to rise or descend.

Press and hold the ▲ key to raise the lift table. The height increase will be displayed on the three-digit digital display. Press and hold the ▼ key to control, When lowering the height-adjustable desk, the reduction in height (as indicated by the displayed numbers) can be observed on the three-digit digital display.

II. Activation and Regulation of Memory Height

1. Controller

On the height display interface, press the number keys to select the desired height, and the lifting table will automatically move to the corresponding position.

In the height display interface, press and hold the M key to make the height value flash. Then press the number keys (1, 2, 3) to adjust the height. The current height is recorded at the corresponding position.

III. Screen-off Wake-up

1. Controller

When the controller is powered off, the display turns off. Press any button to illuminate the digital display.

2. Other model hand controllers

When the controller's screen is turned off, it displays a blackout status. Press any button to turn on the digital display.

IV. Reduction

Hold the "▽" key for 5 seconds after the lifting leg stops. The controller will display "rst", indicating the reset process has begun. Do not release the "▽" key during this phase. Slowly lower the lifting leg until it reaches the lowest point. Wait until the leg fully descends to the minimum position and rebounds 1cm before releasing the "▽" key. The reset operation is now complete.

If an emergency occurs during the reduction process, the "▽" key can be released at any time to stop the leg elevation movement and resume. Position reset termination. After reset termination, the reset operation must be re-executed until successful; otherwise, no further actions can be performed operate .

V. Sedentary reminder

1. To enable, disable, or adjust the sitting reminder duration, use the Sitting Reminder button:

Press the sedentary reminder  button once to enter settings. After entering, the handle displays 0.5H, with each button press increasing the duration by 0.5 hours. The adjustable duration range is 0.5 to 2.0 hours. After three button presses, the sedentary reminder function activates. When the set duration reaches the high display level, it turns off (OFF), indicating the sedentary reminder is disabled.

2. The default sedentary reminder function is disabled by default when the controller leaves the factory.

3. After each reminder, to reactivate this feature, follow the activation steps again.

VI. Pediatric Locks

Press and hold the "△" and "▽" keys for 5 seconds simultaneously. When the controller displays "LOC", it indicates the system is locked and lifting operations are not permitted. In the locked state, continue holding the "△" and "▽" keys for 5 seconds. If the controller transitions from "LOC" to normal numeric display, the system has been unlocked.

7. technical parameter

Height range	Standard: 600mm to 1250mm, 700mm to 1200mm; custom orders for non-standard clients
Frame stretching length	1006mm ~ 1800mm
Elevation rate	Section 3: 30 mm per second; Section 2: 20 mm per second
Weight capacity	80kg (800N).
Operational cycle time	Run for 2 minutes, then rest for 18 minutes
Noise	≤50 Hz
Service environment	-5°C ~ +40°C
Pigment	Black, White, Gray (Custom)

8. Precautions and Warranty Scope

- ◆ This product must be used in compliance with specified technical parameters;
- ◆ Keep away from corrosive gases and dusty environments, and ensure waterproofing;
- ◆ Please contact our company immediately if any issues arise.
- ◆ Defects caused by product quality issues during the warranty period (within one year from the date of purchase) and under normal usage conditions;
- ◆ Do not open this product yourself. Opening it will void all warranty services.