

# ASSEMBLY INSTRUCTIONS

## DINING TABLE

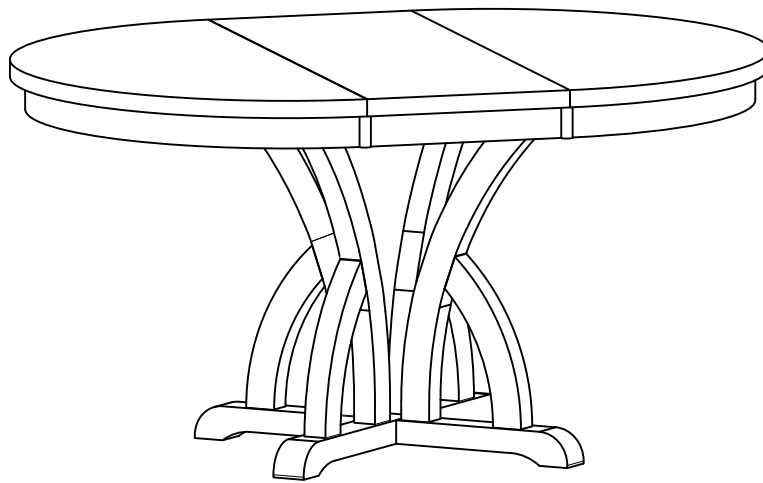

**WF318063**

### **IMPORTANT NOTE:**

- PLACE ALL PARTS ON A CLEAN AND SMOOTH SURFACE SUCH AS A RUG OR CARPET TO AVOID THE PARTS FROM BEING SCRATCHED.
- BEFORE YOU BEGIN, KINDLY FOLLOW THE ASSEMBLY INSTRUCTIONS STEP BY STEP.
- DO NOT TIGHTEN ALL SCREWS AND BOLTS UNTIL THE TABLE IS FULLY SET-UP.

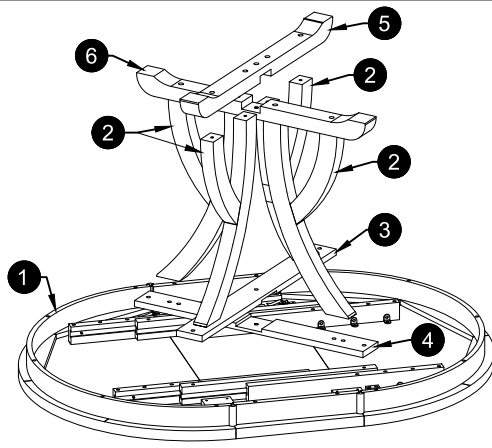

### CARTON CONTENT:

WF318063:



1 x 1

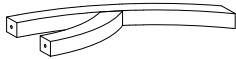

2 x 4

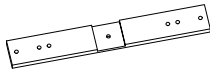

3 x 1

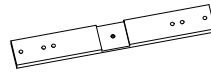

4 x 1

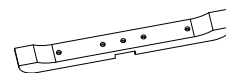

5 x 1

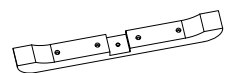

6 x 1

#### TABLE PART LISTS

NO.	DESCRIPTION	SKETCH	QTY
1	TABLE TOP		1 PC
2	TABLE LEG		4 PCS
3	LEG SUPPORT ( L )		1 PC
4	LEG SUPPORT ( R )		1 PC
5	BOTTOM LEG ( L )		1 PC
6	BOTTOM LEG ( R )		1 PC

#### TABLE HARDWARE LISTS

NO.	DESCRIPTION	SKETCH	QTY
A	JCBC BOLT M6 x 60mm		8 PCS
B	JCBC BOLT M6 x 40mm		12 PCS
C	JCBC BOLT M6 x 20mm		2 PCS
D	SPRING WASHER 1/4"		22 PCS
E	FLAT WASHER 1/4"		21 PCS
F	ALLEN KEY M4		1 PC

#### STEP 1

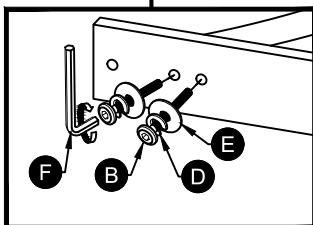
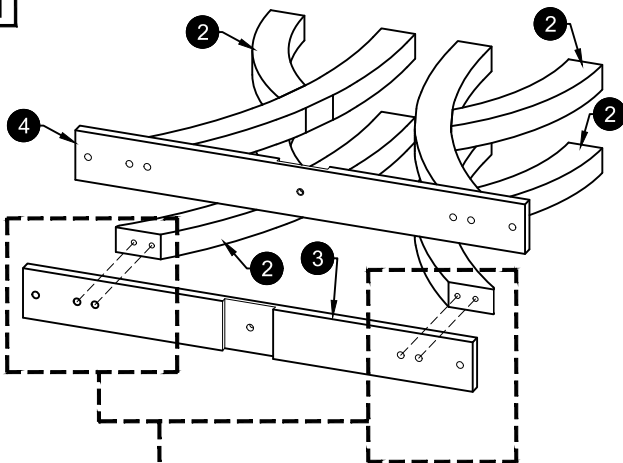

#### STEP 2

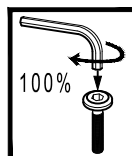
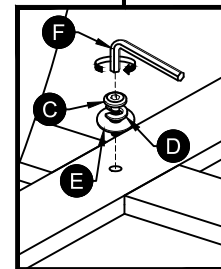
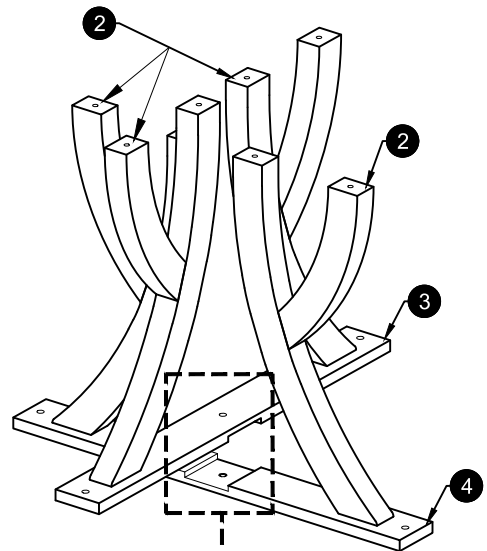

STEP 3

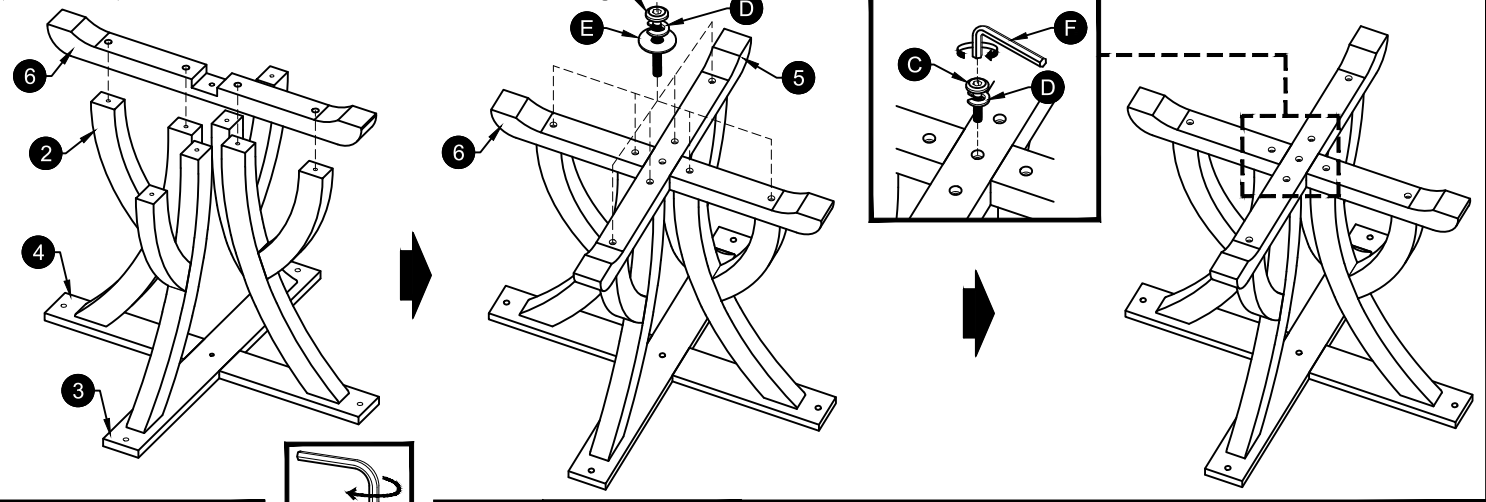

STEP 4

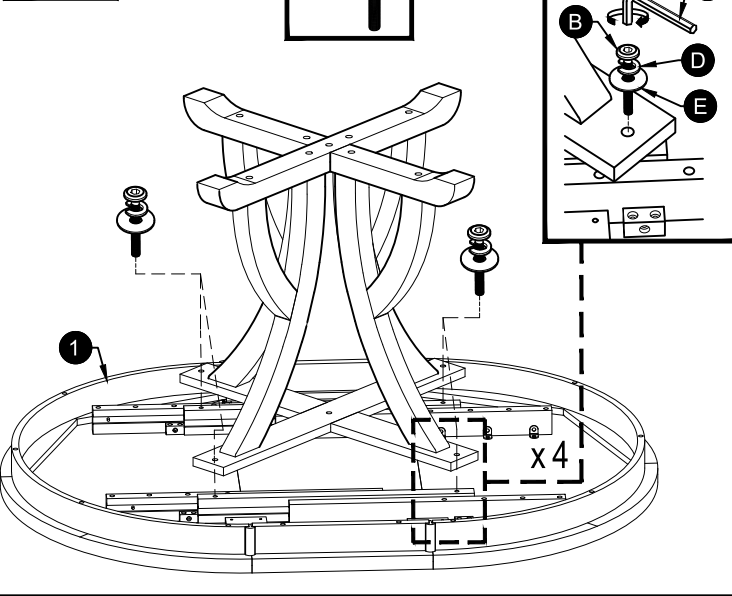

STEP 5

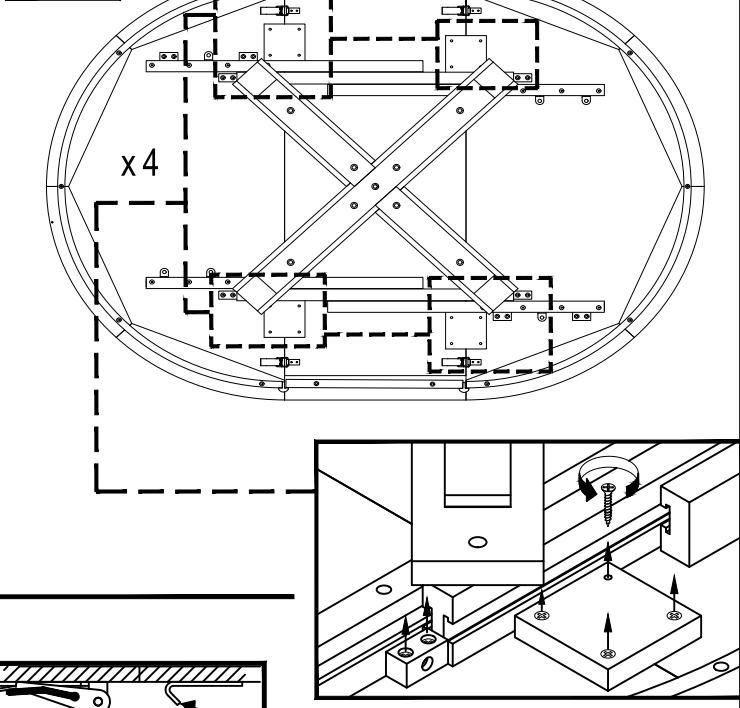

STEP 6

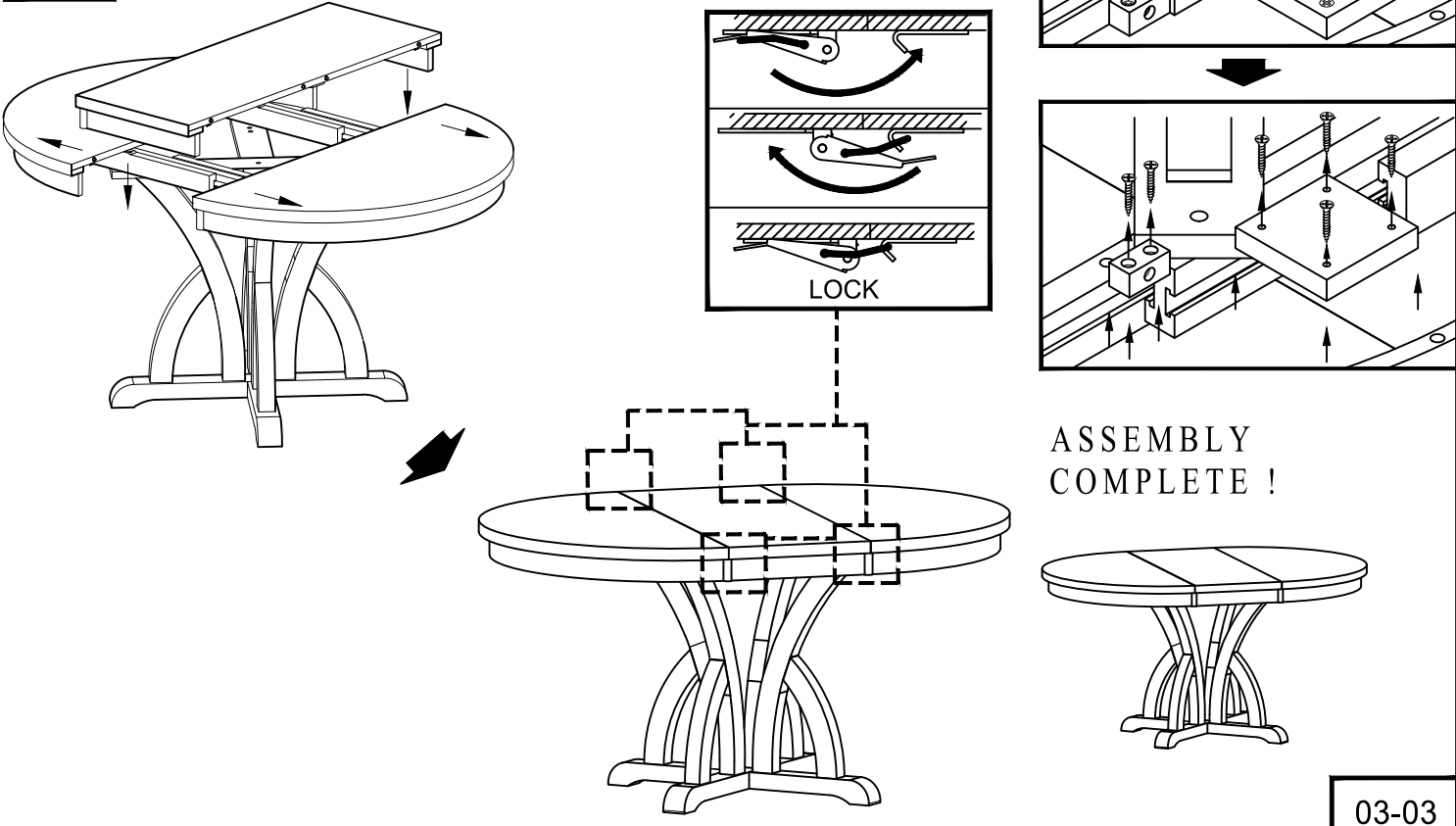

ASSEMBLY COMPLETE !

# ASSEMBLY INSTRUCTIONS

## DINING CHAIR

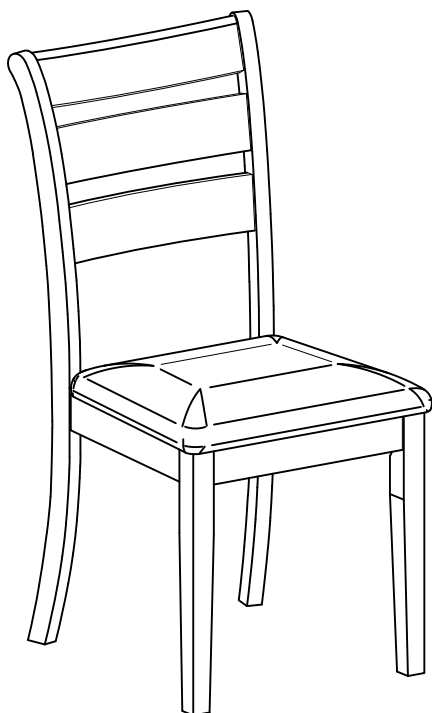

**WF318064**

### **IMPORTANT NOTE:**

- PLACE ALL PARTS ON A CLEAN AND SMOOTH SURFACE SUCH AS A RUG OR CARPET TO AVOID THE PARTS FROM BEING SCRATCHED.
- BEFORE YOU BEGIN, KINDLY FOLLOW THE ASSEMBLY INSTRUCTIONS STEP BY STEP.
- DO NOT TIGHTEN ALL SCREWS AND BOLTS UNTIL THE CHAIR IS FULLY SET-UP.

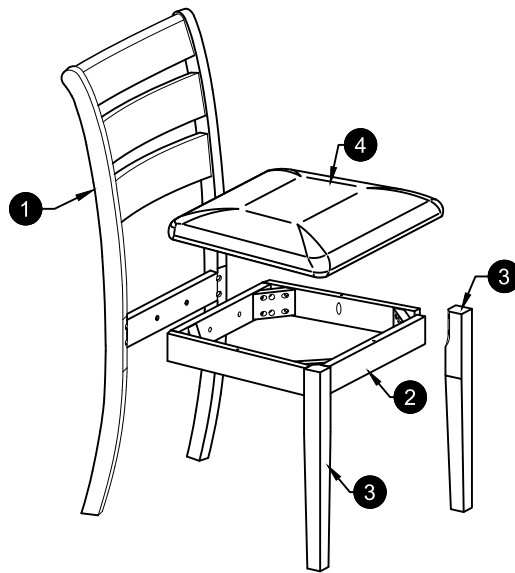

### CARTON CONTENT:

WF318064

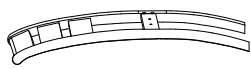

1 x 4

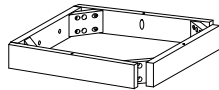

2 x 4

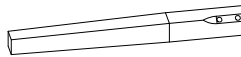

3 x 8



4 x 4

#### CHAIR PART LISTS

NO.	DESCRIPTION	SKETCH	QTY
1	BACK REST		4 PCS
2	BOX SEAT		4 PCS
3	FRONT LEG		8 PCS
4	SEAT		4 PCS

#### CHAIR HARDWARE LISTS

NO.	DESCRIPTION	SKETCH	QTY
A	JCBC BOLT M6 x 35mm		8 PCS
B	JCBC BOLT M6 x 60mm		16 PCS
C	JCBC BOLT M6 x 80mm		16 PCS
D	SPRING WASHER 1/4"		40 PCS
E	FLAT WASHER 1/4"		40 PCS
F	ALLEN KEY M4		1 PC
G	C/B SCREW M4 x 30mm		12 PCS

NOT INCLUDED

#### STEP 1

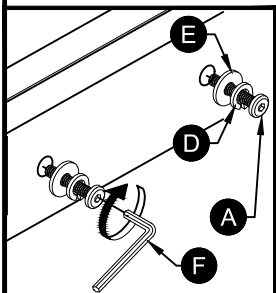
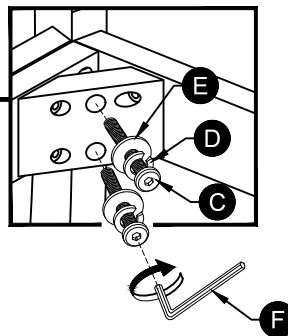
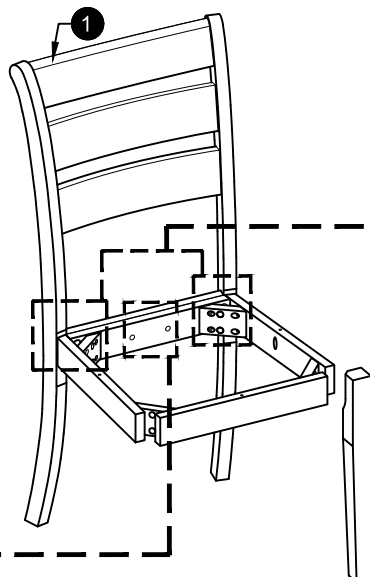
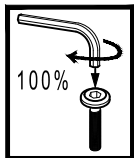

STEP 2

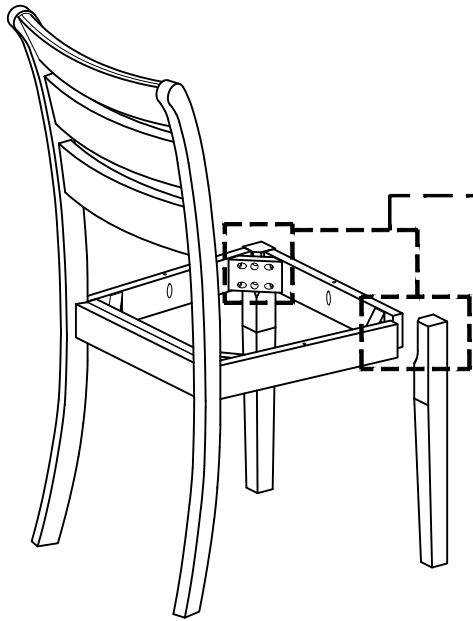

x 2

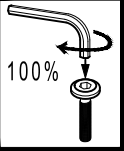
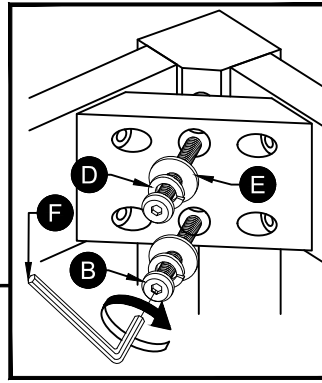

STEP 3

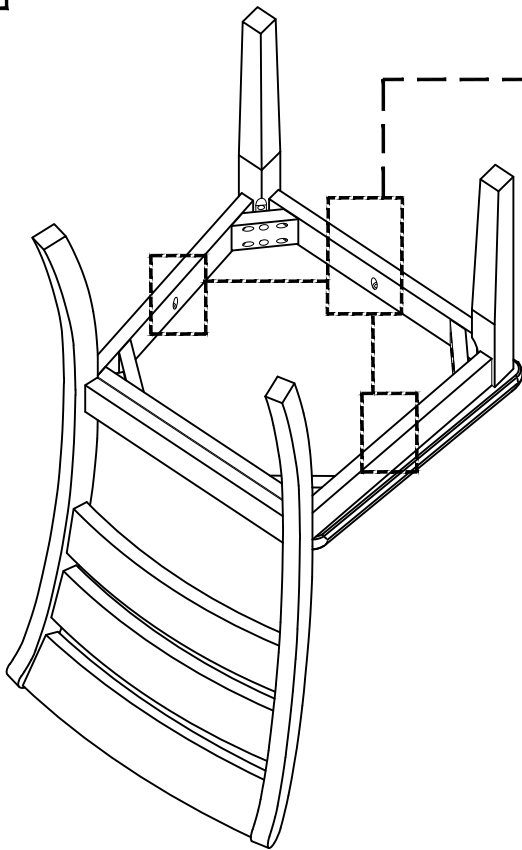

x 3

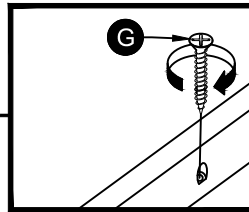

ASSEMBLY COMPLETE !

