

Assembly Instructions



ASSEMBLY RATING

The Assembly Rating is a 5-point system that shows the degree of effort needed in assembling a specific product (with 1 being easy and 5 being difficult). For some products, two persons are recommended.

EASY  DIFFICULT

Tools Required for Assembly:

Allen Wrench



(Included)

Wrench

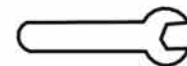

(Included)

Phillips Screwdriver



(Not Included)



2 PERSONS RECOMMENDED

ASSEMBLY & CARE ADVICE

FOR YOUR FURNITURE TO LAST, CORRECT ASSEMBLY AND PROPER MAINTENANCE ARE NECESSARY. PLEASE FOLLOW THE INFORMATION PROVIDED BELOW TO FULLY ENJOY YOUR FURNITURE.

BASIC ASSEMBLY TECHNIQUES

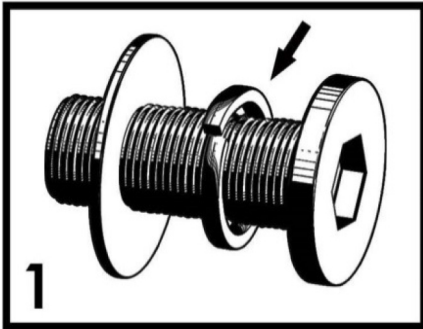

1 When lock or spring washer is used in an assembly, please make sure the lock or spring washer is placed between the larger flat washer and the head of the screw or bolt.



2 Position each part correctly and insert screws or bolts into their respective holes by hand tighten or using the proper hand tool. Only tighten when step is completed or when instructed to do so.

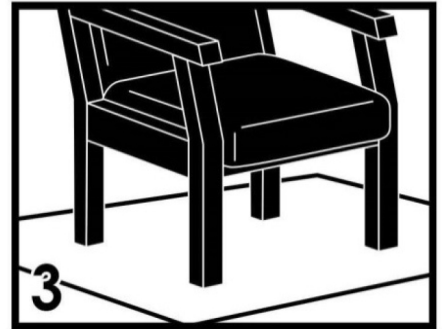

3 Use cardboard or carpet area when assembling furniture to prevent scratches. Make sure the furniture rests on a flat and level surface with each leg evenly touching the floor.

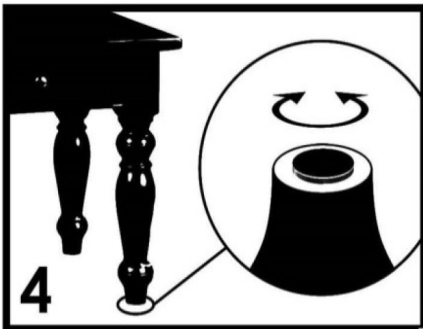

4 Some furniture comes with height adjustment knobs underneath each leg. To lower or to raise each leg, you need to turn clockwise or counterclockwise, respectively.

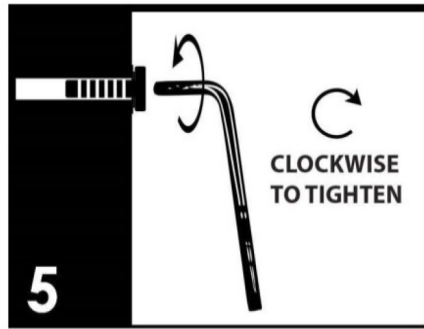

5 Make sure all parts are properly aligned, then use the appropriate hand tool to completely tighten the bolts or screws. Do not use power tools and do not overtighten.

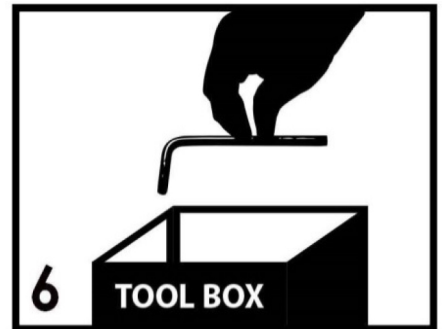

6 Save the instructions and store the Allen wrench or any supplied tool for later maintenance. After two weeks, check and tighten any loose hardware and repeat again every six months thereafter.

IT IS THE USER'S RESPONSIBILITY TO MAINTAIN THE FURNITURE. THE HARDWARE MAY LOOSEN OVER TIME AND MAY CAUSE THE FURNITURE TO BE WOBBLY AND UNABLE TO SUPPORT ITS INTENDED WEIGHT CAPACITY. THIS MAY LEAD TO COLLAPSE AND MAY CAUSE SERIOUS INJURY.



FAILURE TO FOLLOW THE GUIDELINES ABOVE MAY RESULT IN INJURY AND/OR PROPERTY DAMAGE.

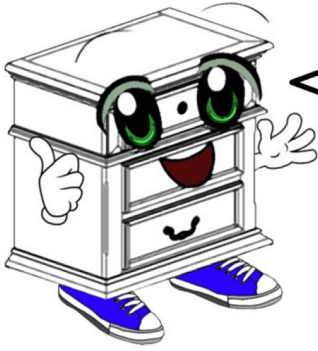

Before you begin, please read Page 2 of "Assembly and Care Advice".

And remember, do not tighten until each step is completed or instructed.

MD

Parts List

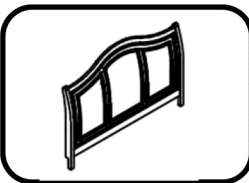

#1 x 1 pc
Headboard

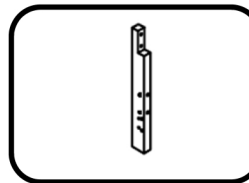

#2R x 1 pc
Right H/Board Leg

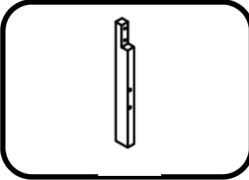

#2L x 1 pc
Left H/Board Leg

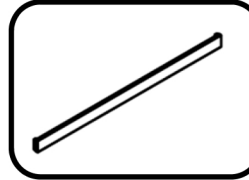

#3 x 1 pc
Leg Support

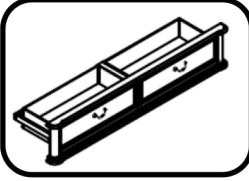

#4 x 1 pc
Footboard w/Drawers



#5 x 2 pcs
Footboard Foot

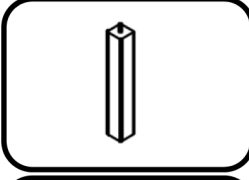

#6 x 3 pcs
F/B Support Leg

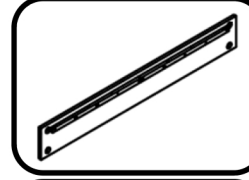

#7 x 2 pcs
Side Rail

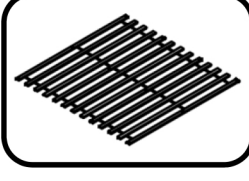

#8 x 1 kit
Slat 13 pcs

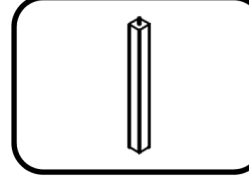

#9 x 3 pcs
Slat Support Leg

Note: Right and left are determined by facing the front of the bed in the upright position.

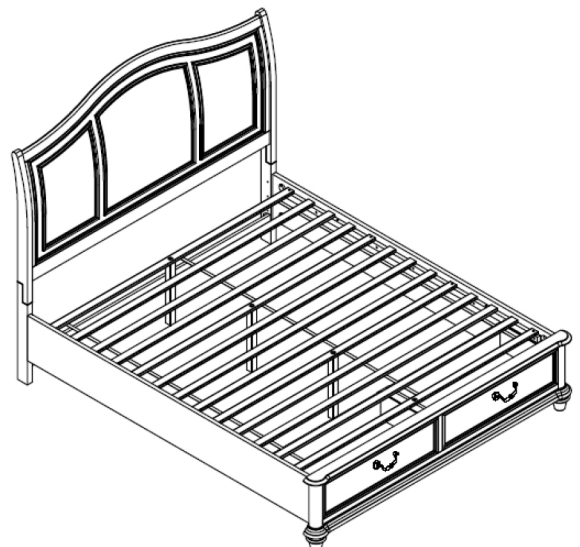



Due to the size and/or weight of this product, it is highly recommended that the assembly should be done near the area of its intended location. Make sure you have enough space to move around during the assembly. ALWAYS have at least two people to help with transporting and assembling the product to avoid any potential injury and/or damage.

Hardware List



#A x 4 pcs
Bolt 1/4"x1-1/2"

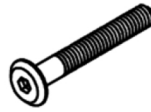

#B x 4 pcs
Bolt 1/4"x2-1/8"



#C x 8 pcs
Lock Washer



#D x 8 pcs
Flat Washer

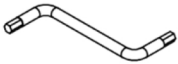

#E x 1 pc
Allen Wrench



#F x 8 pcs
Threaded Stud



#G x 8 pcs
Hex Nut



#H x 8 pcs
Beveled Washer

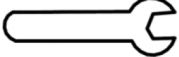

#I x 1 pc
Wrench

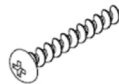

#J x 8 pcs
Screw 1-1/4"



- I. Align the leg support (#3) with the pre-drilled holes of the right headboard leg (#2R) and the left headboard leg (#2L).
- II. Prepare 4 bolt assemblies by inserting FIRST the lock washer (#C) onto the bolt (#A) and then the flat washer (#D) onto the SAME bolt (#A), in that order.
- III. Insert the bolt assemblies through the leg support (#3) using the Allen wrench (#E) to lock them with the right headboard leg (#2R) and the left headboard leg (#2L).

#A x 4 pcs
#C x 4 pcs
#D x 4 pcs

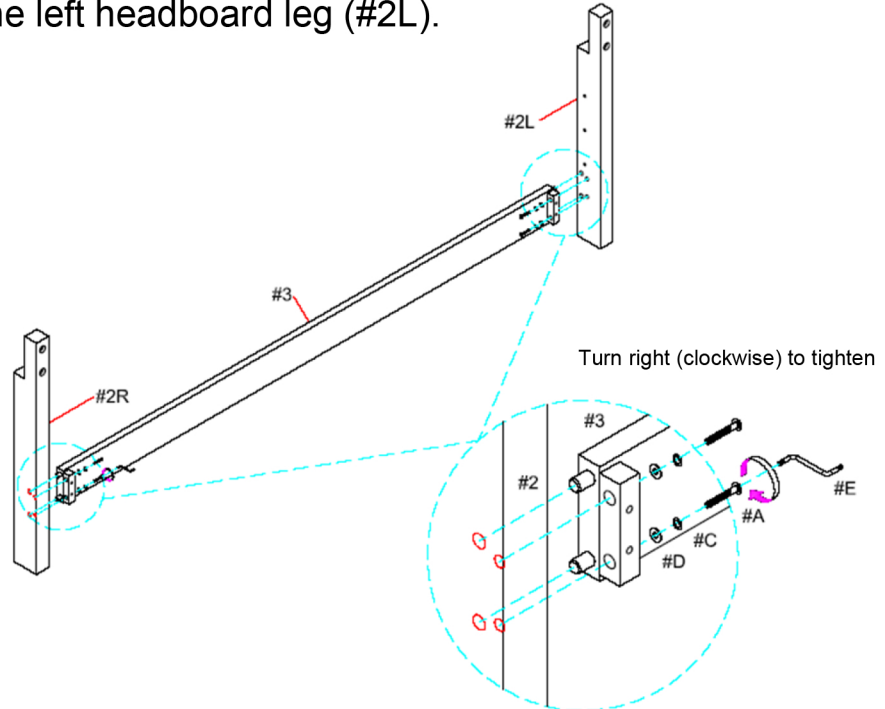

- I. With the help of another person, carefully align the headboard (#1) with the pre-drilled holes of the right headboard leg (#2R) and the left headboard leg (#2L).
- II. Prepare 4 bolt assemblies by inserting FIRST the lock washer (#C) onto the bolt (#B) and then the flat washer (#D) onto the SAME bolt (#B), in that order.
- III. Insert the bolt assemblies through the pre-drilled holes of the right headboard leg (#2R) and the left headboard leg (#2L) and secure those bolts using the Allen wrench (#E) to lock them with the headboard (#1).

#B x 4 pcs
#C x 4 pcs
#D x 4 pcs

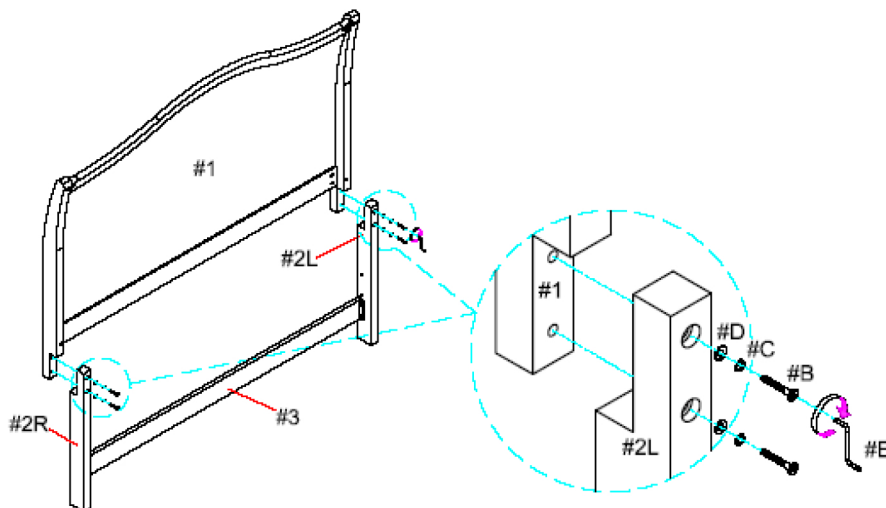



- I. Remove the 2 drawers from the footboard (#4).
- II. Align the threaded ends of the 2 footboard feet (#5) with the pre-drilled holes on the bottom of the footboard (#4) and tighten by hand until secured.
- III. Align the threaded ends of the 3 footboard support legs (#6) with the pre-drilled holes on the bottom of the footboard drawer and tighten by hand until secured.

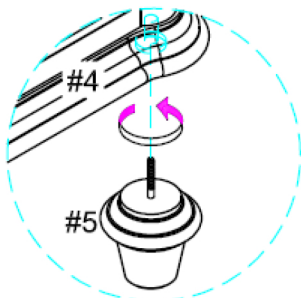
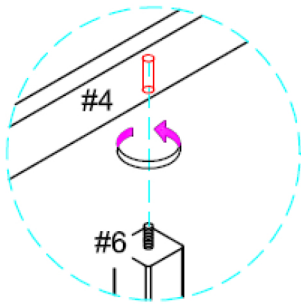

Turn right (clockwise) to tighten

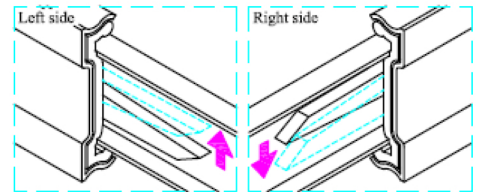
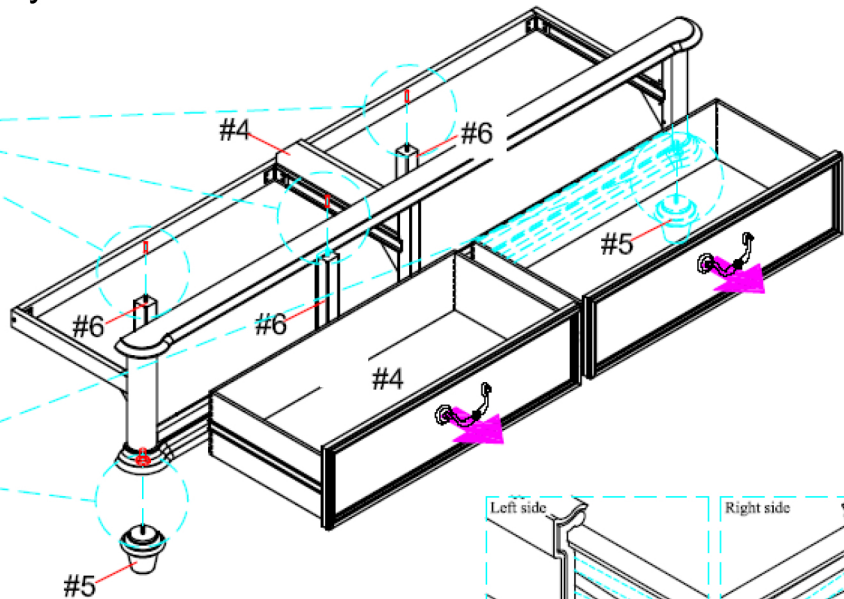

#F x 8 pcs
#G x 8 pcs
#H x 8 pcs

- I. Insert 4 threaded studs (#F) into the right headboard leg (#2R) and the left headboard leg (#2L).
- II. Insert one side rail (#7) onto the 2 threaded studs (#F) on the right headboard leg (#2R). Then insert 2 beveled washers (#H) onto the 2 threaded studs (#F) and secure with the 2 hex nuts (#G) using the wrench (#I) to tighten. Repeat the process to secure the other side rail (#7) onto the left headboard leg (#2L).
- III. Repeat the process above to assemble the other ends of the 2 side rails (#7) onto the footboard (#4).

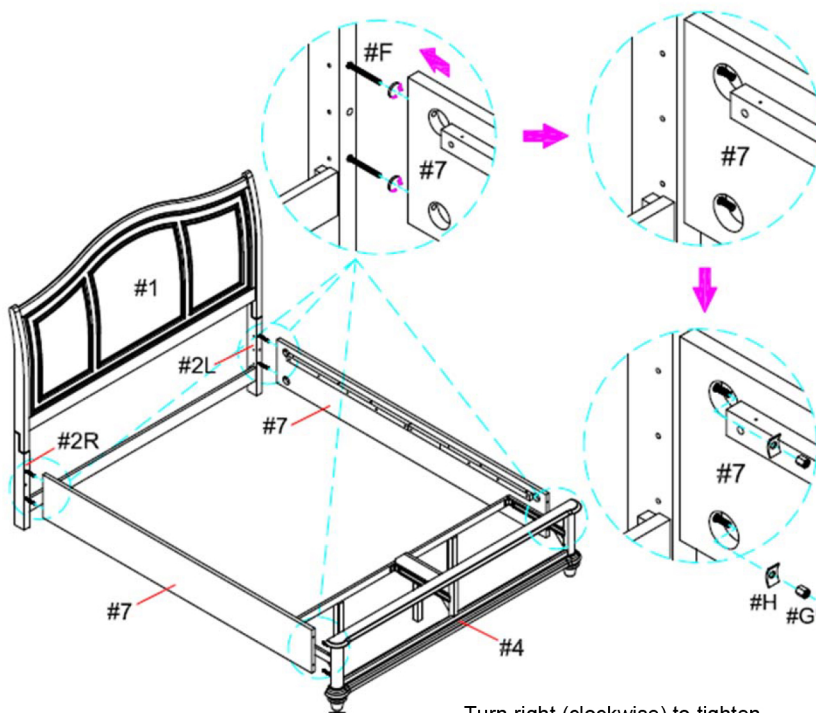

Turn right (clockwise) to tighten



Align the threaded ends of the 3 slat support legs (#9) with the pre-drilled holes along the center of the slat kit (#8) and tighten by hand until secured.

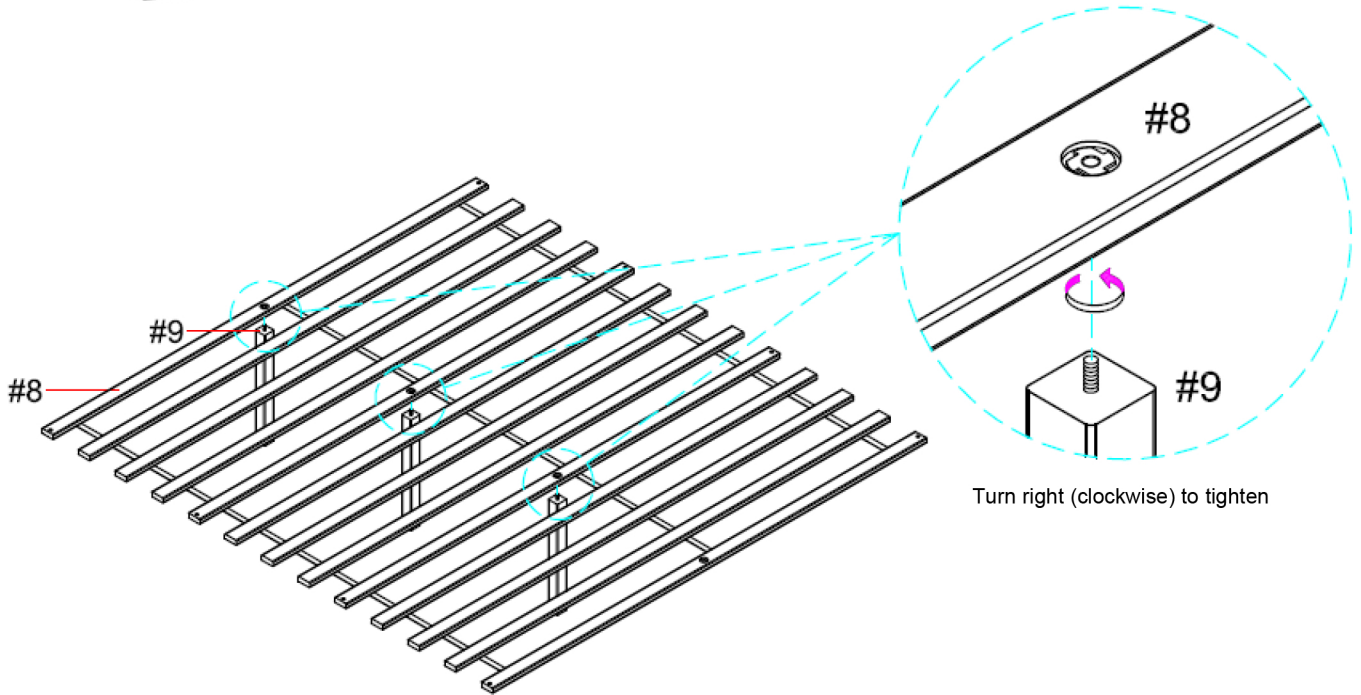

- I. Align the ends of the assembled slat kit (#8) with the pre-drilled holes on the side rails (#7).
- II. Secure 8 screws (#J) onto the ends of the slat kit (#8) using a Phillips screwdriver to tighten them down to the side rails (#7).

#J x 8 pcs

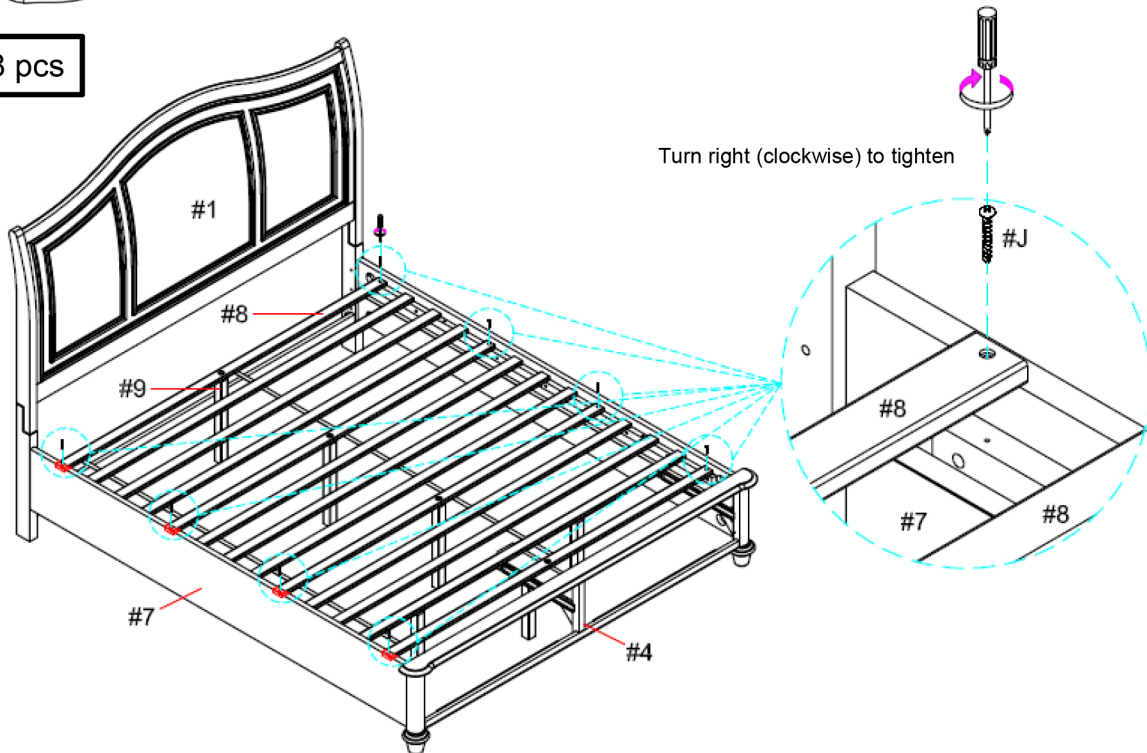



- I. Insert the two drawers back into the footboard (#4).
- II. Make sure the bed is rested on a flat surface and does not feel loose or wobbly. If it does, double check that the bolts/screws are secured and properly tightened.

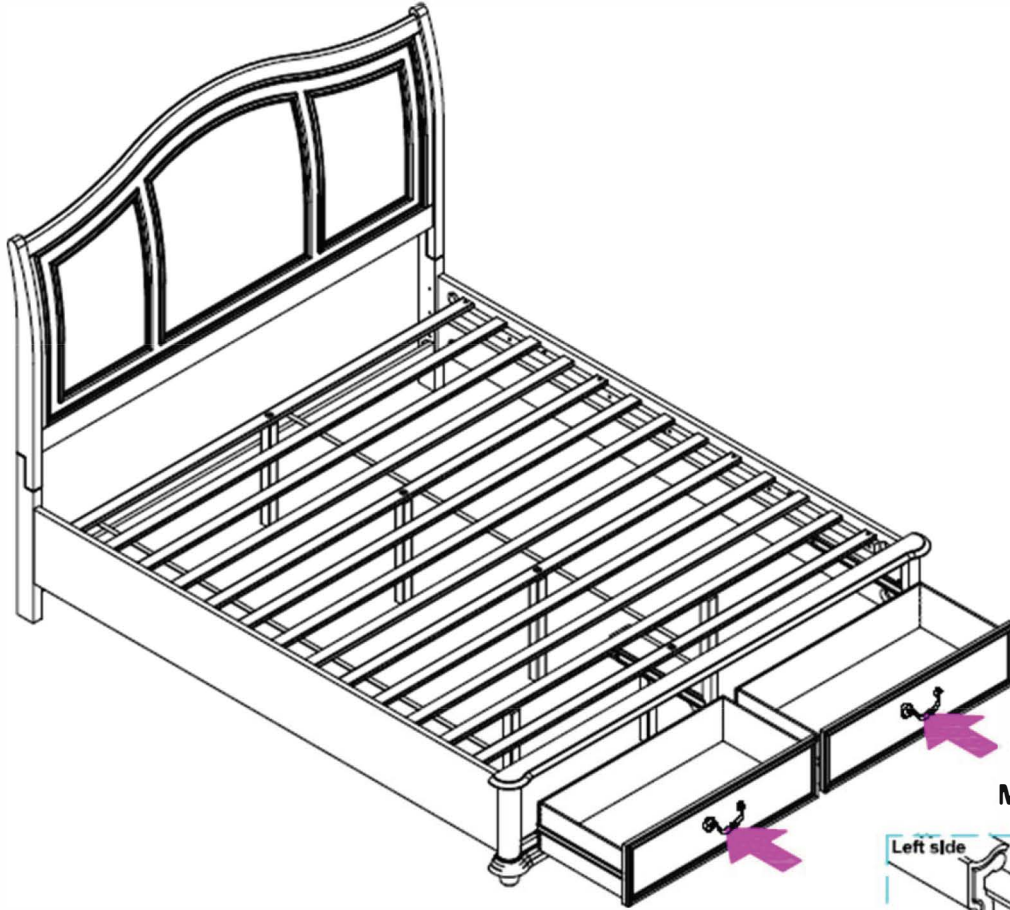

Must be fix and preclslon

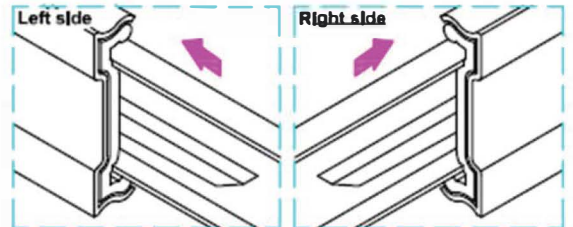

ASSEMBLY IS COMPLETED