

ASSEMBLY INSTRUCTIONS

Before you begin, please follow assembly instructions carefully, then follow them step by step.

Read instruction carefully . See Furniture Parts list and Hardware List for guidance . Be sure you have all parts before you start assembling . Place and assemble furniture on a clean flat soft surface , such as carpet or rug to prevent being scratched .

PART LIST		QTY
1	TOP TRAY	1 PC
2	BOTTOM PANEL	1 PC
3	SIDE PANEL (L)	1 PC
4	SIDE PANEL (R)	1 PC
5	MIDDLE PANEL	1 PC
6	BONE PANEL	2 PCS
7	SHELF PANEL	2 PCS
8	BACK PANEL	1 PC
9	DRAWER FRONT (UP)	1 PC
10	DRAWER FRONT (DOWN)	2 PCS
11	DRAWER SIDE	6 PCS
12	DRAWER BACK	3 PCS
13	DRAWER BOTTOM	3 PCS
14	LEG	4 PCS

HARDWARE				
A	MINI FIX	A1 A2 A3	8 PCS	
B	M8 X 30MM WOOD DOWEL		20 PCS	
C	M6 X 50MM CSK CAP WOOD SCREW		4 PCS	
D	5/8 NAIL		56 PCS	
E	ALLEN KEY M4		1 PC	
F	ONE HOLE L BRACKET (2MM)		4 PCS	
G	M3.5 X 16MM C.B SCREW		44 PCS	
H	M4 X 38MM C.B SCREW		24 PCS	
I	METAL SHELF SUPPORT		8 PCS	
J	10" DRAWER SLIDE	J1 (L/R) J2 (L/R)	3 SETS	
K	JCBC Screw M6 x 70		8 PCS	
L	SPRING WASHER M6		8 PCS	
M	FLAT WASHER M6		8 PCS	
N	TIPPING PACK		2 SETS	

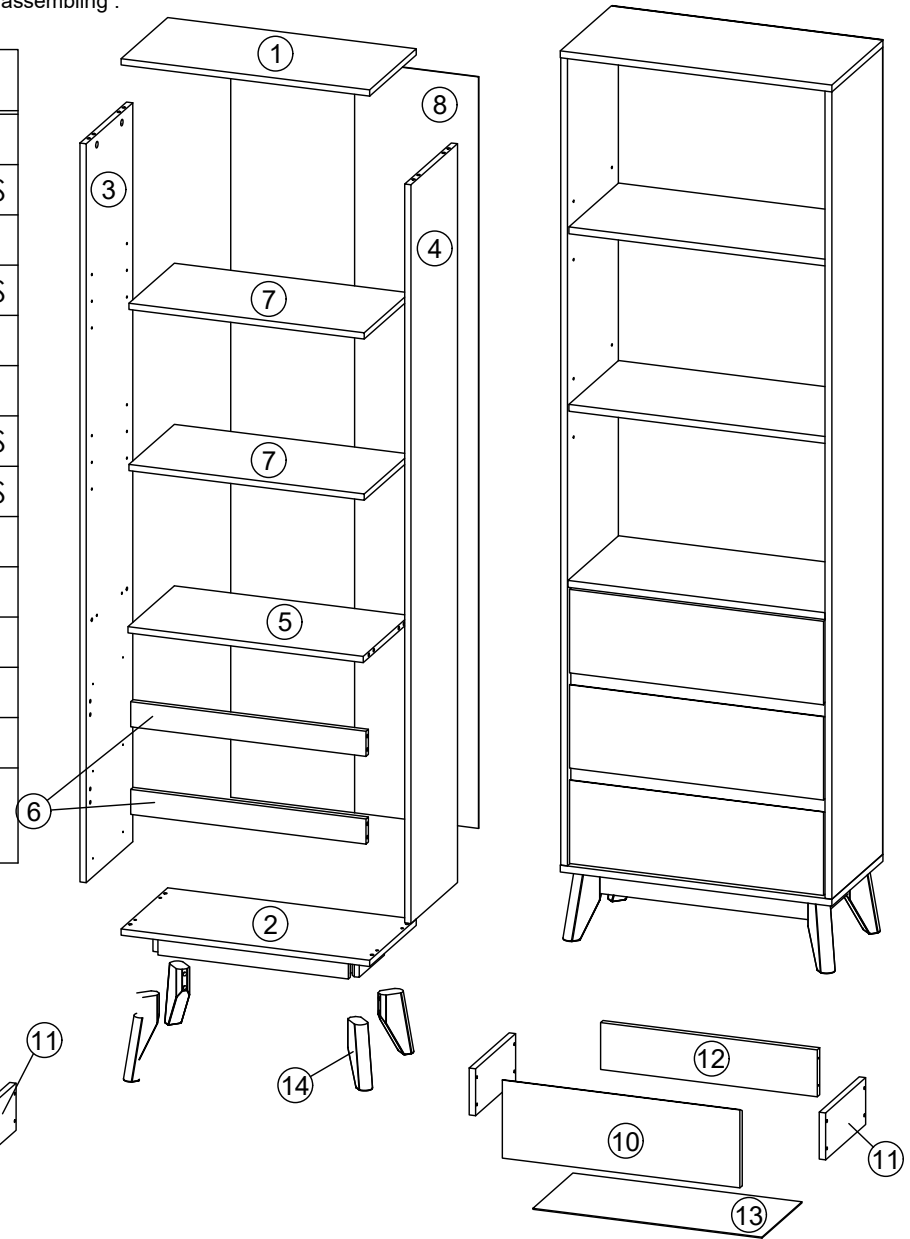

SELF-PREPARED TOOLS: Tools below are NOT included in package.

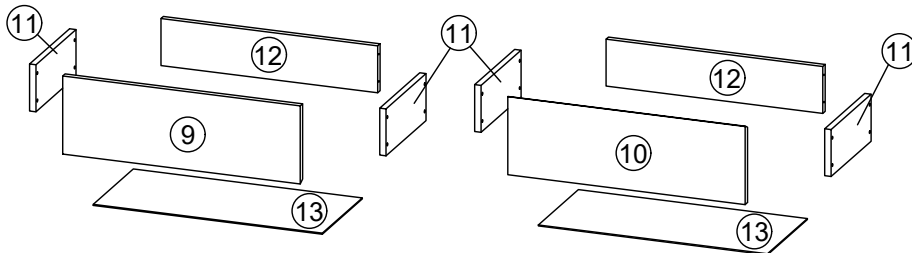
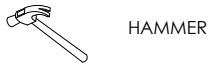

Reminder:

Please ensure that all surfaces and edges with colours/laminations are facing forward/outward.

ASSEMBLY INSTRUCTIONS

STEP 1

- Insert hardware **A1** onto panel **(5)**.
(Repeat 4 times.)
- Insert hardware **A2** onto panel **(1)**.
(Repeat 4 times.)
- Insert hardware **B** onto panel **(5)**.
(Repeat 4 times.)

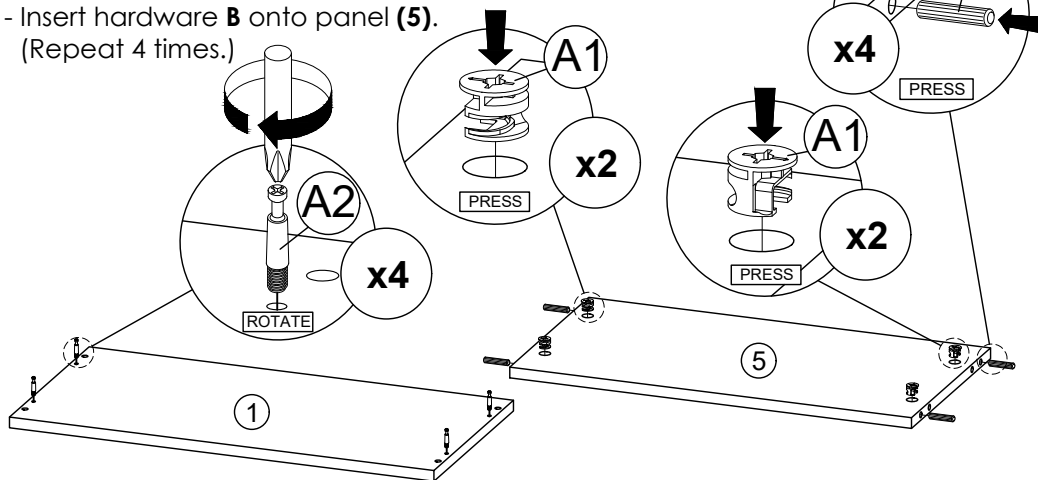

* Ensure the arrows on hardware **A1** point towards mounting positions.

STEP 2

- Insert hardware **A1** onto panel **(3)** and **(4)**.
(Repeat 4 times.)
- Insert hardware **A2** onto panel **(3)** and **(4)**.
(Repeat 4 times.)
- Insert hardware **B** onto panel **(3)** and **(4)**.
(Repeat 8 times.)

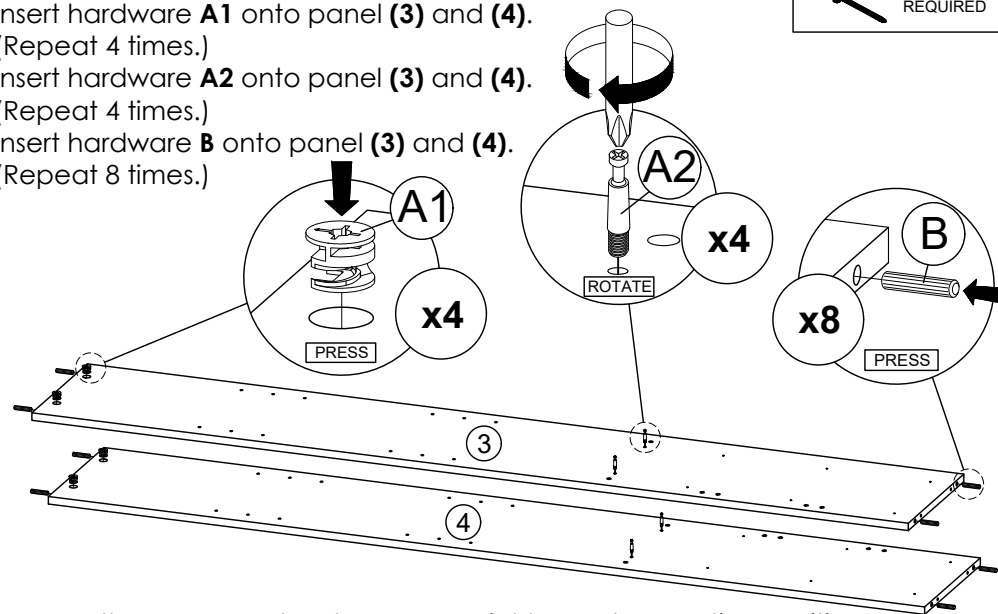

* Ensure the arrows on hardware **A1** point towards mounting positions.

STEP 3

- Assemble hardware **F** to panel **(6)** with hardware **G**.
(Repeat 2 times on each panel.)
- Insert hardware **B** onto panel **(6)**.
(Repeat 4 times on each panel.)

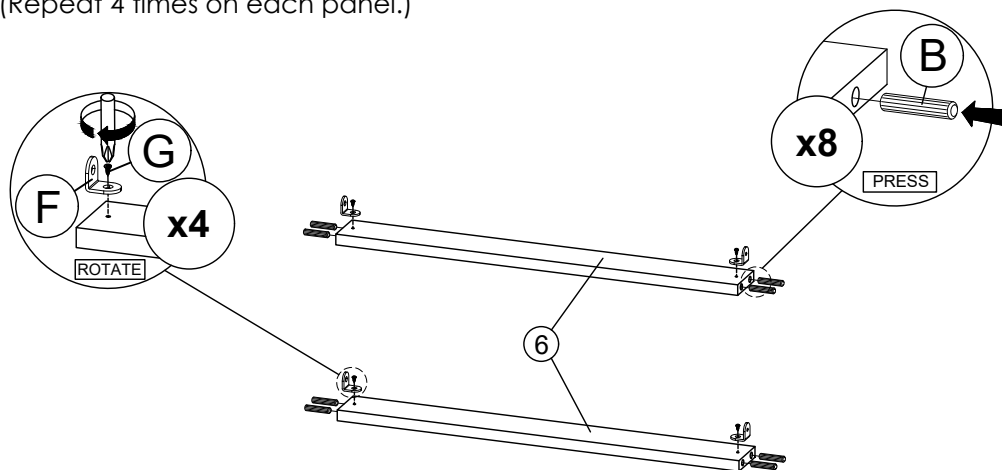

STEP 4

- Fix hardware **J1 (L/R)** into panel **(3)** and **(4)** with hardware **G**.
(Repeat 3 times for each hardware.)

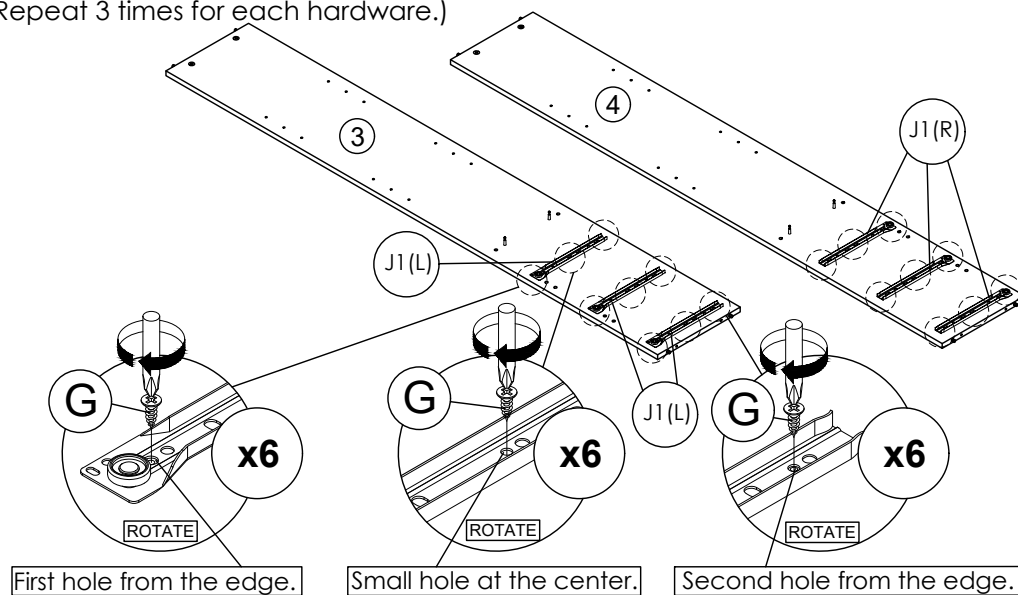

First hole from the edge.

Small hole at the center.

Second hole from the edge.

ASSEMBLY INSTRUCTIONS

STEP 5

- Attach panel (5) to panel (3) and (4).
- Insert all hardware **A2** into **A1**.
- Rotate all **A1** until tight.
- Apply **A3** onto all **A1**.
(Repeat 4 times.)
- Attach panel (6) to panel (3) and (4).
(Repeat 2 times.)

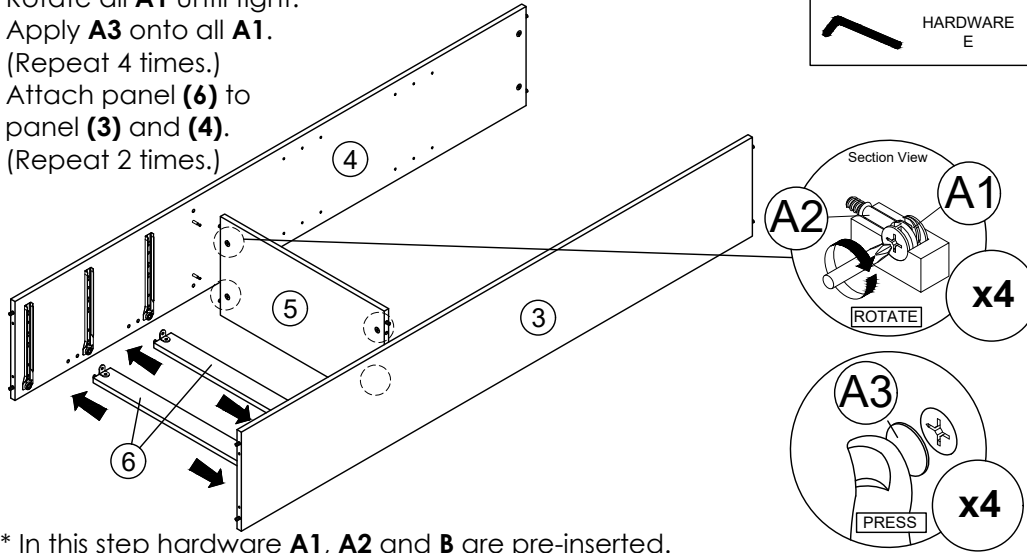
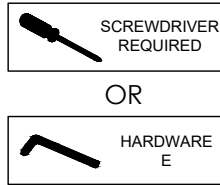

* In this step hardware **A1**, **A2** and **B** are pre-inserted.

STEP 6

- Attach panel (3) and (4) to panel (1).
- Insert all hardware **A2** into **A1**.
- Rotate all **A1** until tight.
- Apply **A3** onto all **A1**.
(Repeat 4 times.)

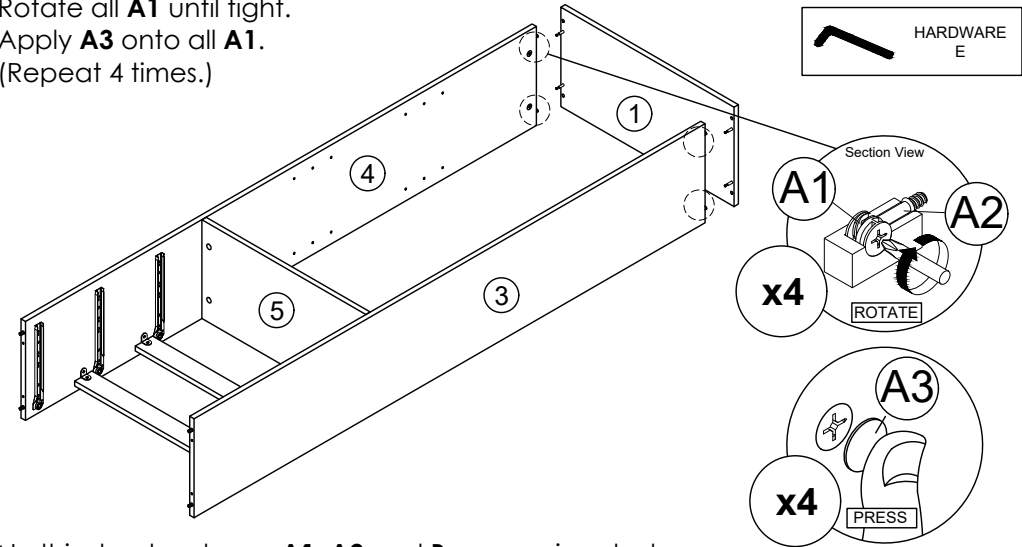
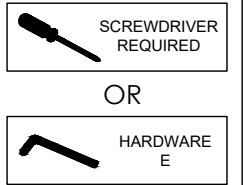

* In this step hardware **A1**, **A2** and **B** are pre-inserted.

STEP 7

- Connect panel (2) to panel (3) and (4) by using hardware **C** and **E**.
(Repeat 4 times.)

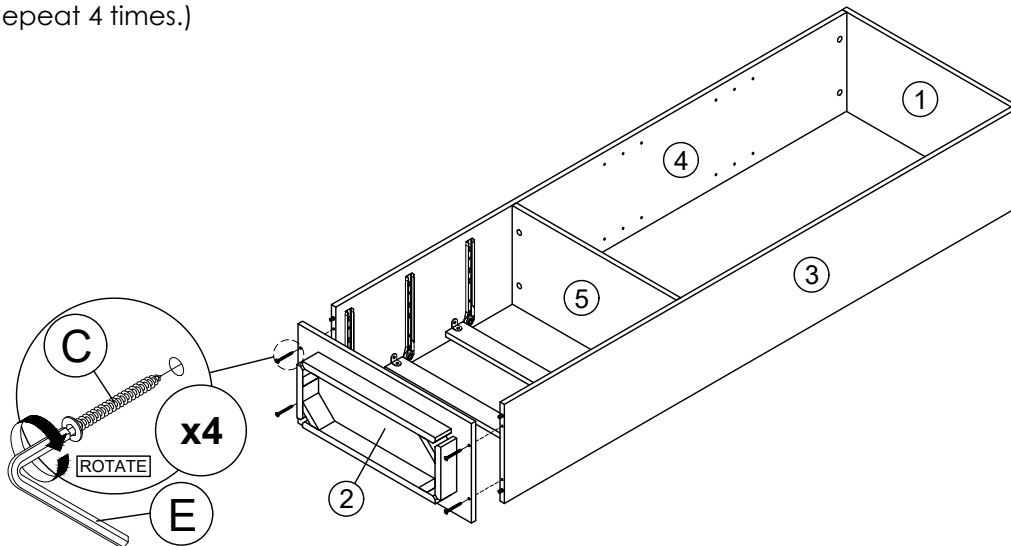

* In this step hardware **B** are pre-inserted.

STEP 8

- Assemble hardware **F** on panel (6) to panel (3) and (4) by using hardware **G**.
(Repeat 1 times on each side panel.)

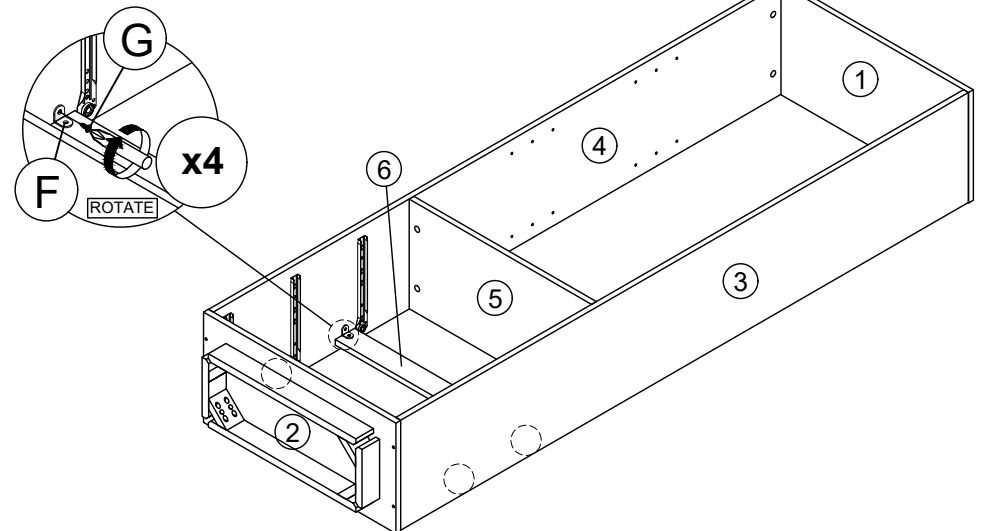

ASSEMBLY INSTRUCTIONS

STEP 9

Assemble part **14** into panel **(2)** by using hardware **E, K, L** and **M**.
(Repeat 2 times for each Leg.)

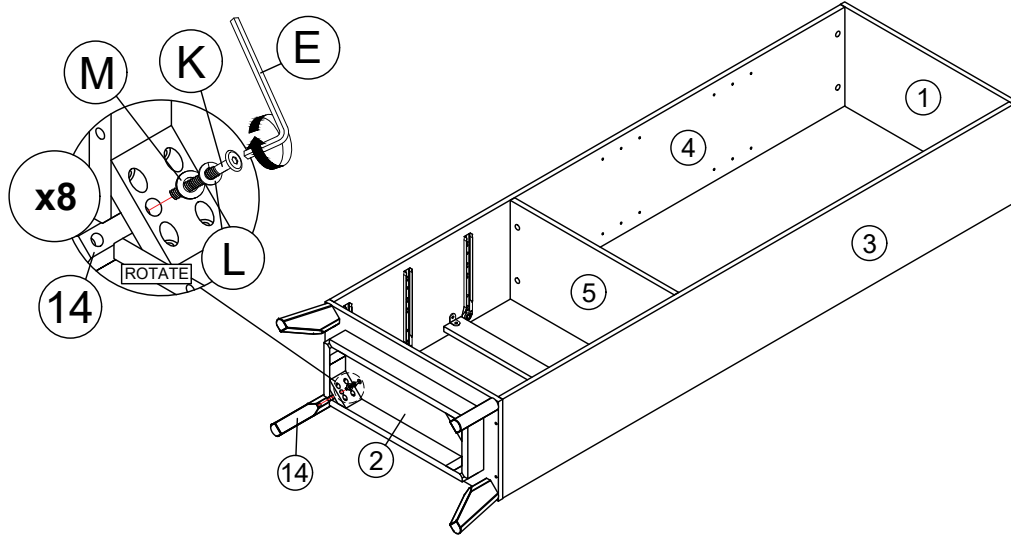

STEP 10

Assemble panel **(8)** to entire body with hardware **D**.
(Repeat 32 times.)

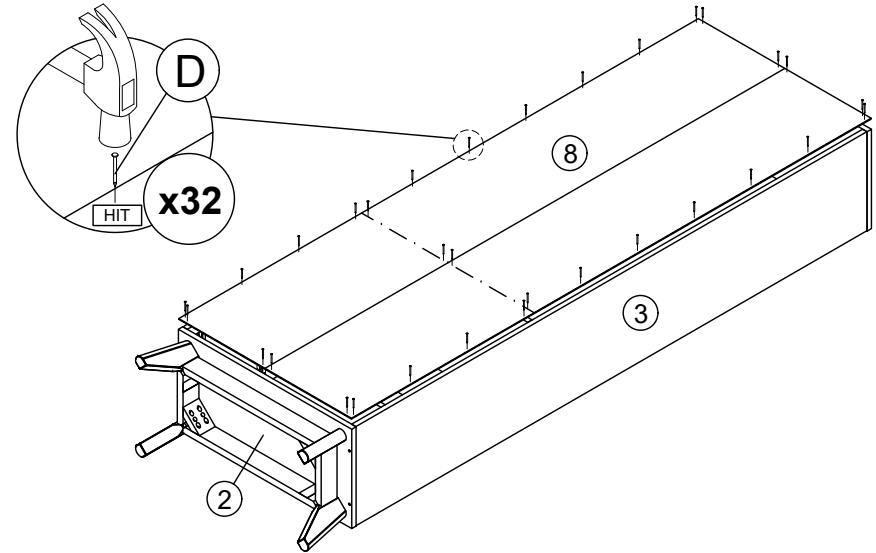

STEP 11

Insert hardware **I** into mounting positions on panel **(3)** and **(4)** by hand.
(Repeat 8 times.)

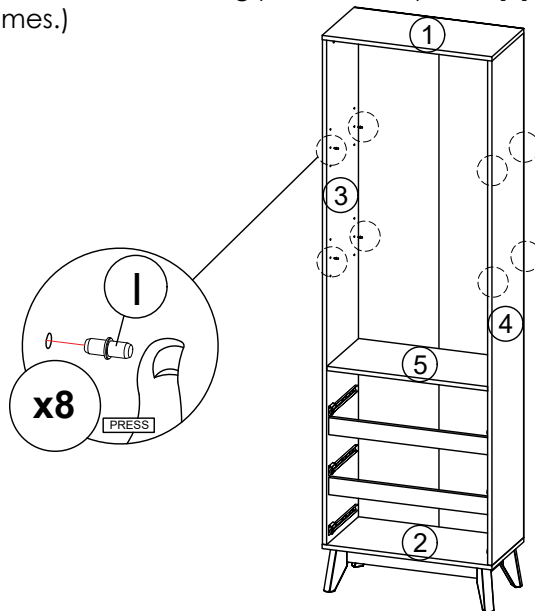

STEP 12

Assemble the panel **(7)** into between panel **(3)** and **(4)**.
(Repeat 2 times.)

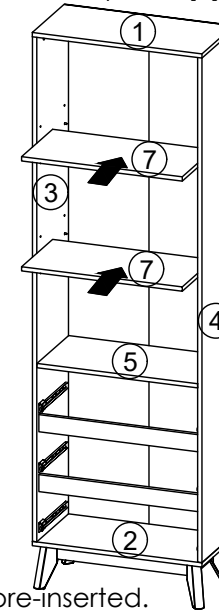

* In this step hardware **I** are pre-inserted.

ASSEMBLY INSTRUCTIONS

STEP 13

Assemble panel (11) with panel (9) or (10) and (12) by using hardware H. (Repeat 8 times for each drawer.)

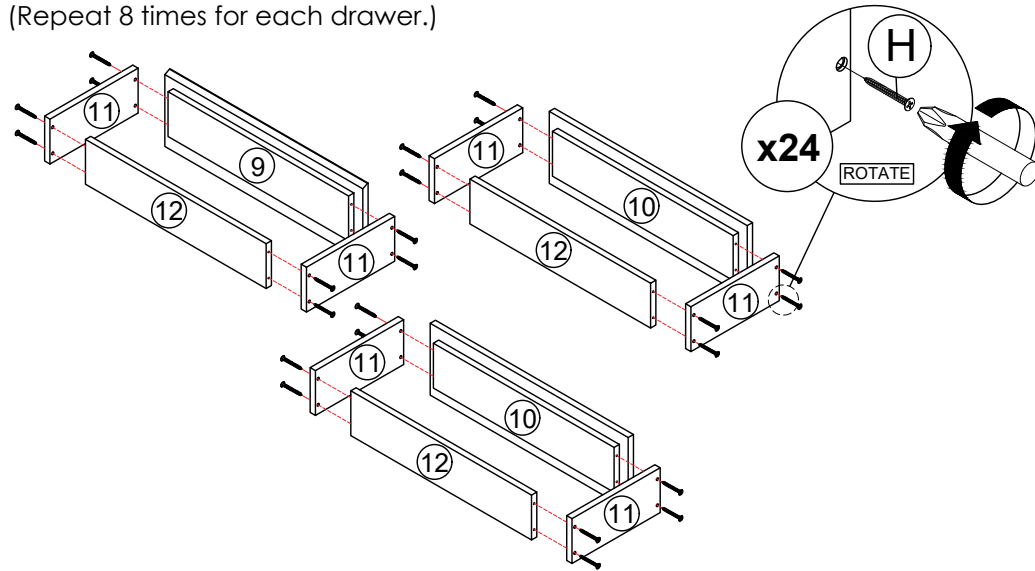

STEP 14

Assemble panel (13) to entire body with hardware D. (Repeat 8 times for each drawer.)

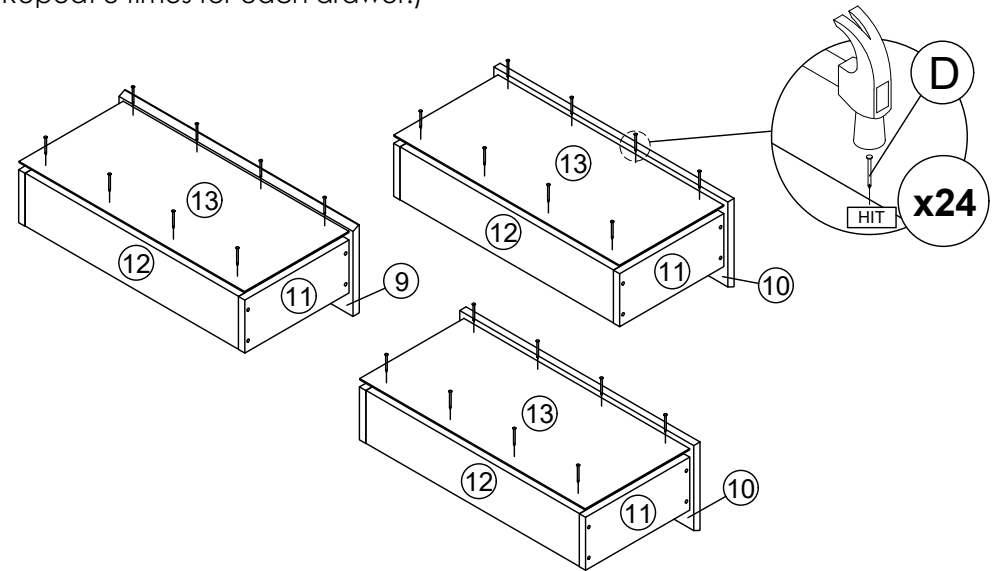

STEP 15

Assemble hardware J2 (L/R) to panel (13) by using hardware G. (Repeat 3 times for each hardware.)

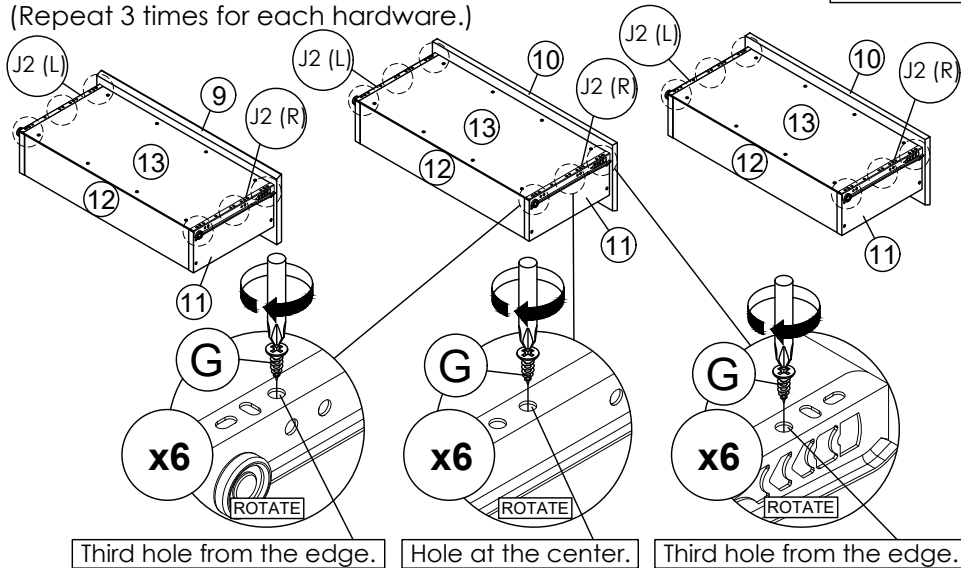

*Hardware J2 (L/R) shall be leaning against panel (9) or (10) when assembling.

STEP 16

Put all the drawer in place along the drawer slides.

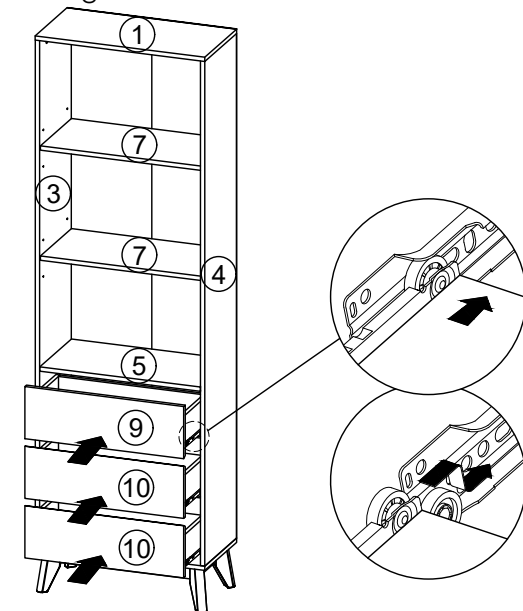

ASSEMBLY INSTRUCTIONS

STEP 17

Assemble hardware **N1** into panel **(1)** and **(8)** by using hardware **N2**.
(Repeat 2 times.)

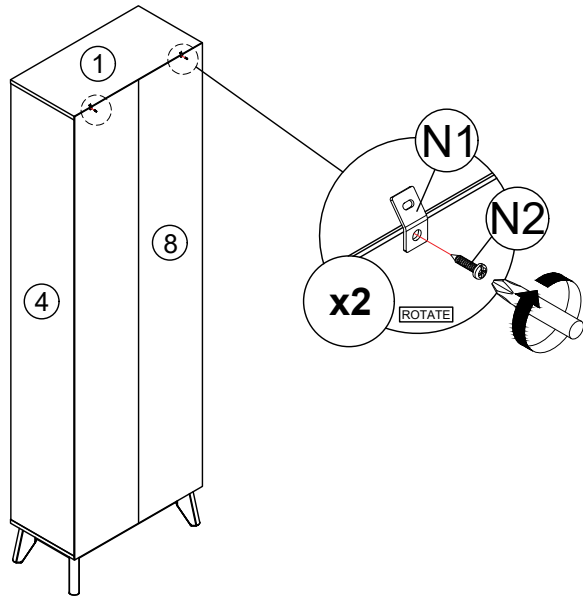

STEP 18

- Mark and use the power drill to drill a hole on the wall.
- Hit hardware **N3** into the wall.
(Repeat 2 times.)

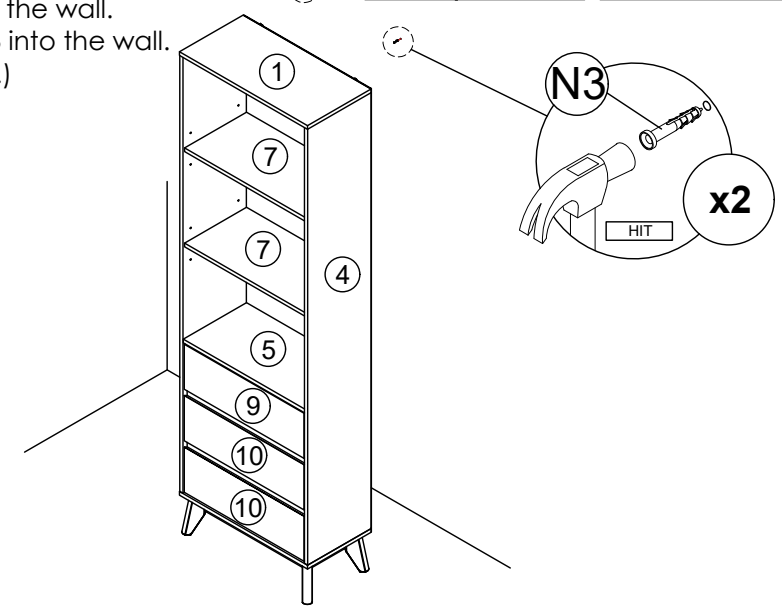

STEP 19

- Assemble hardware **N1** to **N3** by using hardware **N4**.
(Repeat 2 times.)

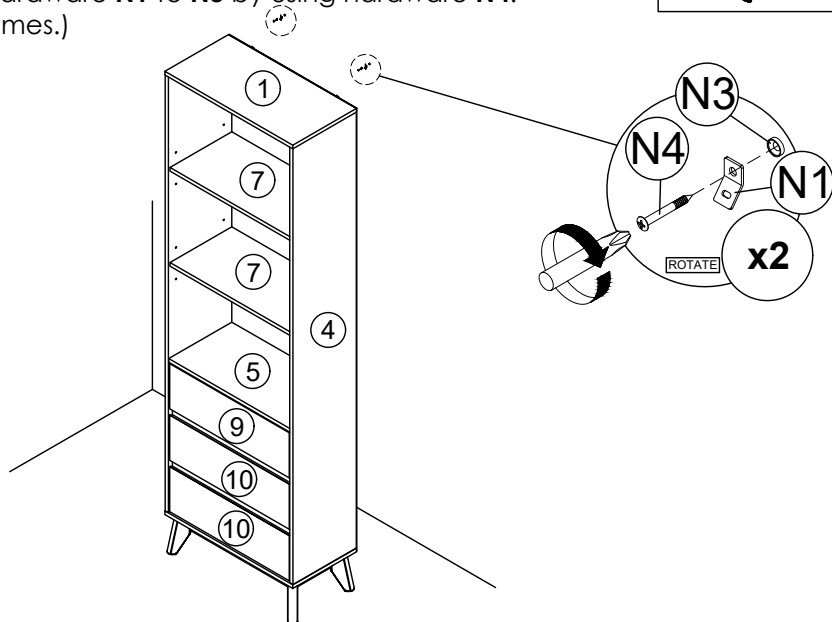

STEP 20

- Connect two of the hardware **N1** by using hardware **N5**.
- Tighten the hardware **N5**.
(Repeat 2 times.)

