

---

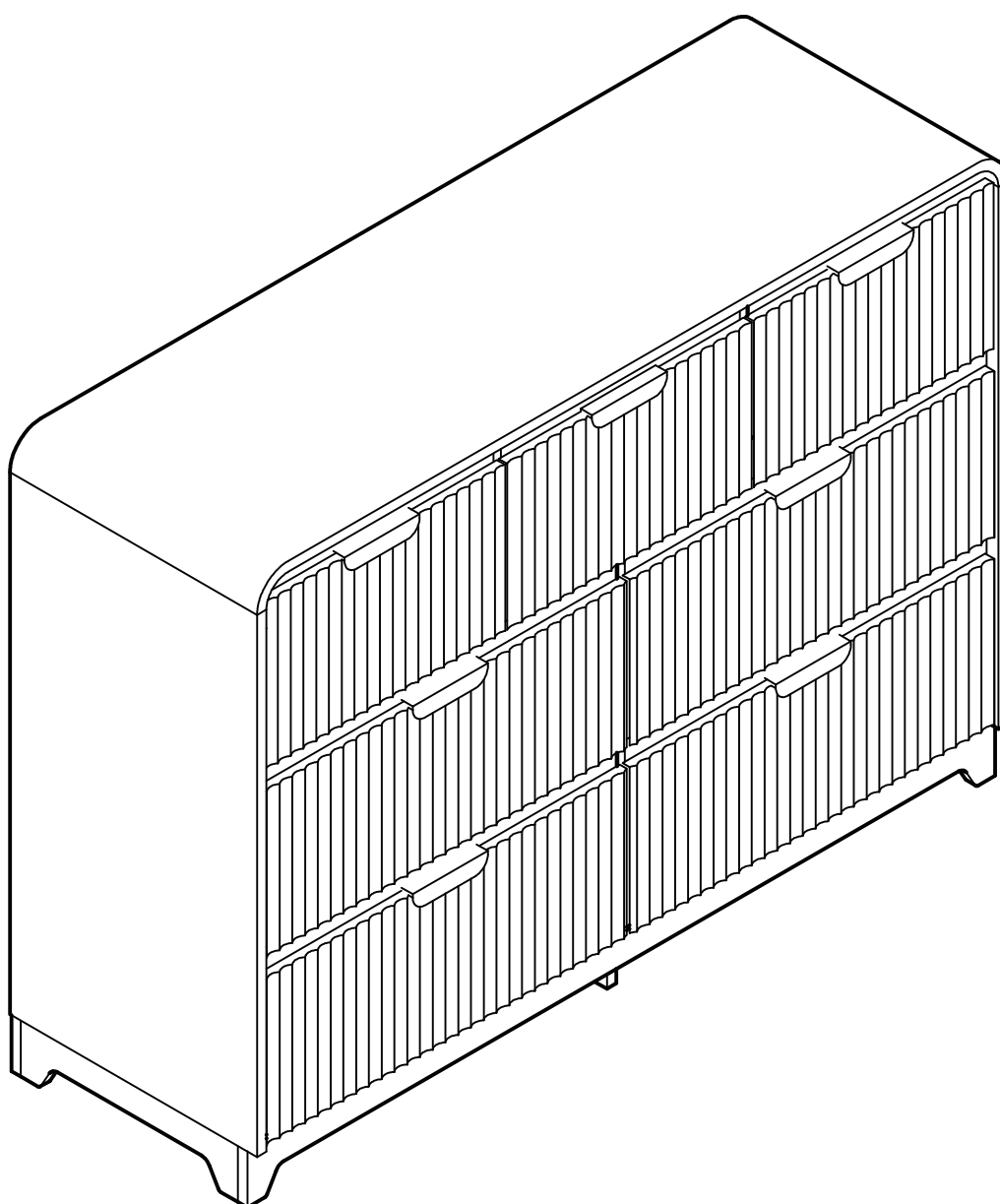







# STORAGE CABINE

- Instruction Manual

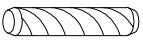
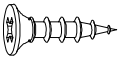
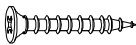
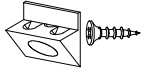

**List Of Installation Parts** ● Before installation, please check all parts for any missing components.

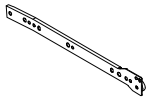
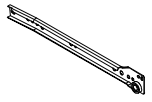
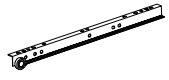
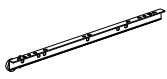
Parts List

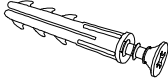
<p><b>A</b></p>  <p><b>7pcs</b></p>	<p><b>B</b> M6×25mm</p>  <p><b>126pcs</b></p>	<p><b>C</b> Ø12mm</p>  <p><b>126pcs</b></p>	<p><b>D</b></p>  <p><b>7pcs</b></p>
<p><b>E</b> Ø8x25mm</p>  <p><b>28pcs</b></p>	<p><b>F</b> M3x12mm</p>  <p><b>79pcs</b></p>	<p><b>G</b> M4x25mm</p>  <p><b>35pcs</b></p>	<p><b>H</b></p>  <p><b>16pcs</b></p>
<p><b>I</b> 25x10x5mm</p>  <p><b>6pcs</b></p>	<p><b>J</b></p>  <p><b>7pcs</b></p>	<p><b>K</b></p>  <p><b>7pcs</b></p>	<p><b>L</b></p>  <p><b>7pcs</b></p>
<p><b>M</b></p>  <p><b>7pcs</b></p>	<p><b>N</b> 65x32x15mm</p>  <p><b>2pcs</b></p>	<p><b>O</b> M4.5x12mm</p>  <p><b>2pcs</b></p>	

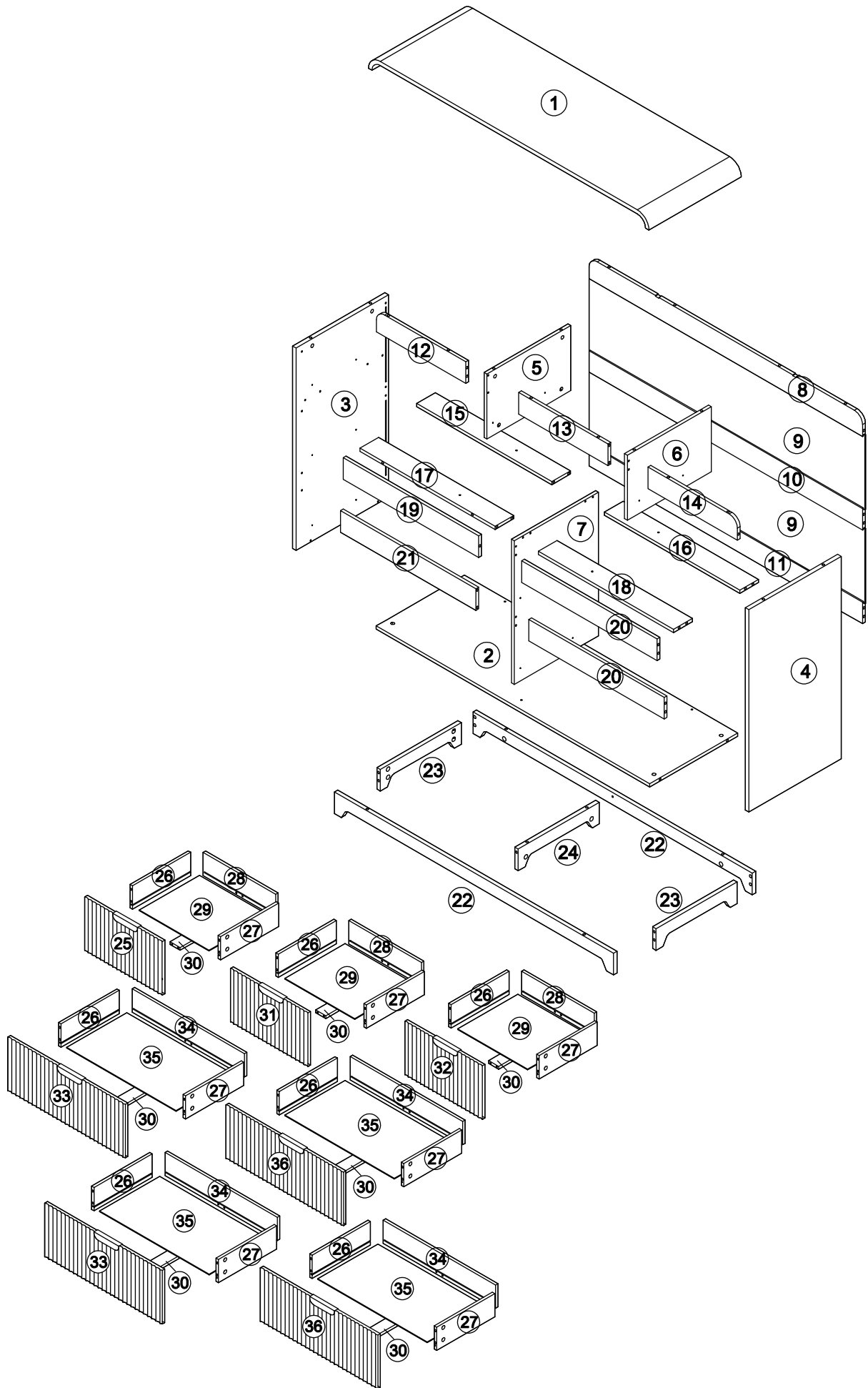

This furniture requires 2 people to assemble.  
Make sure no parts missing or damaged before assembly.

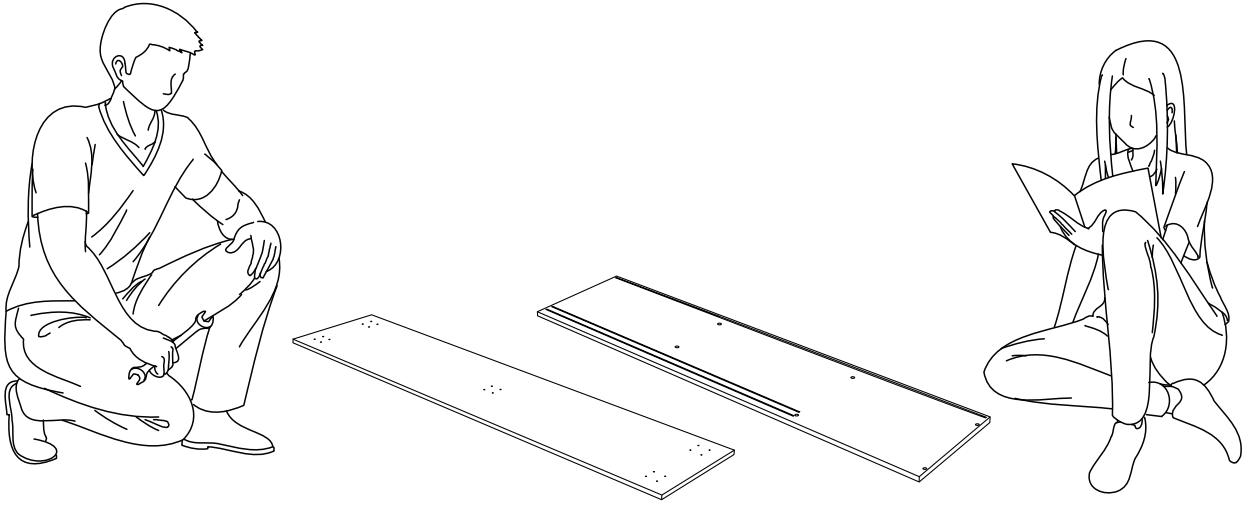

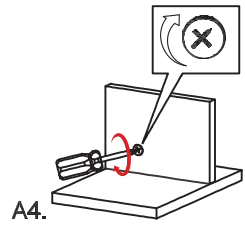
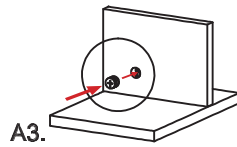
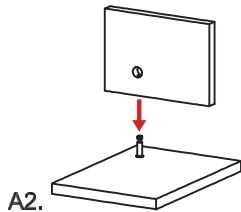
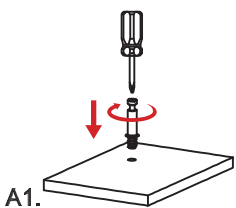
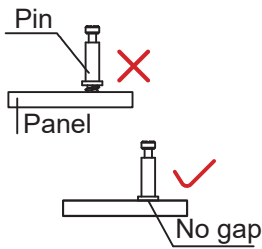
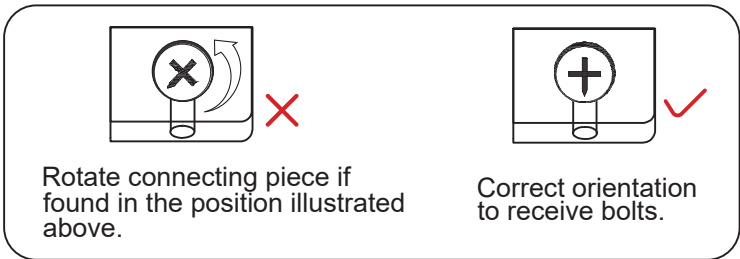
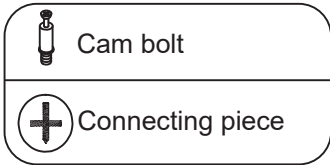

**Cam Bolt Installation As Follows**

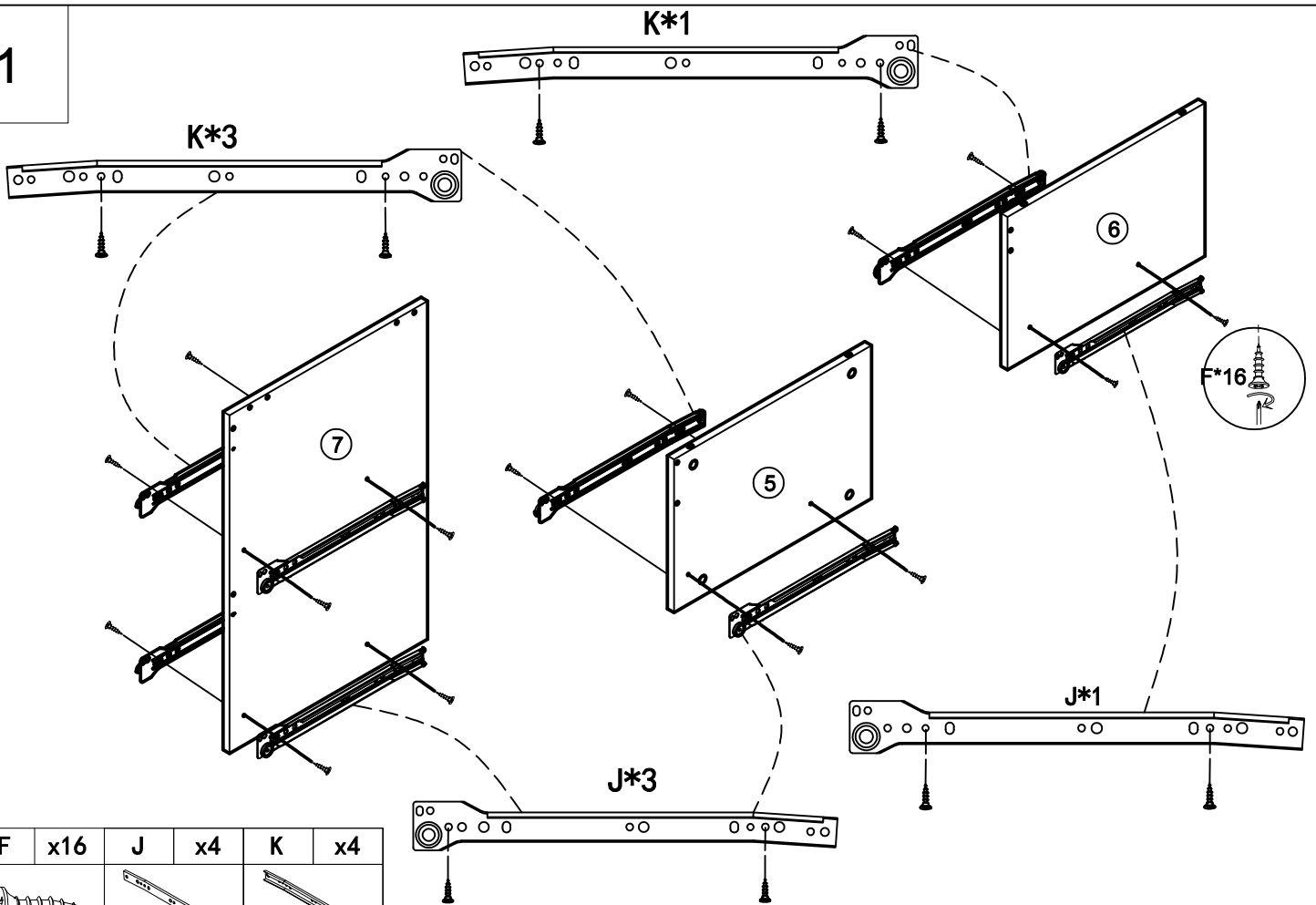

1

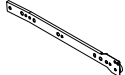



F	x16	J	x4	K	x4
					
M3*12mm		300MM		300MM	

Please ensure the screws on the drawer slides are tightened properly. Loose screws may cause the drawer to stick or jam

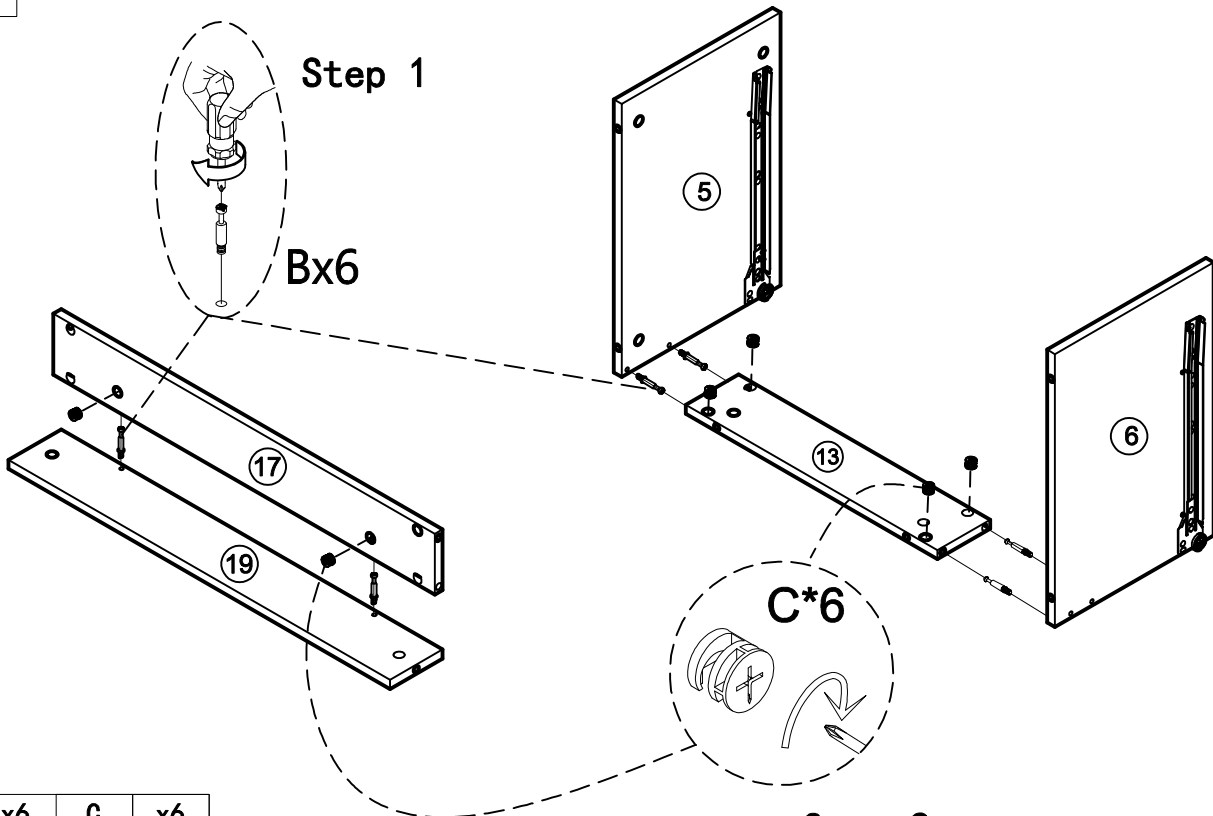

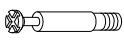
2



B	x6	C	x6
			
M6*25mm		Ø12mm	

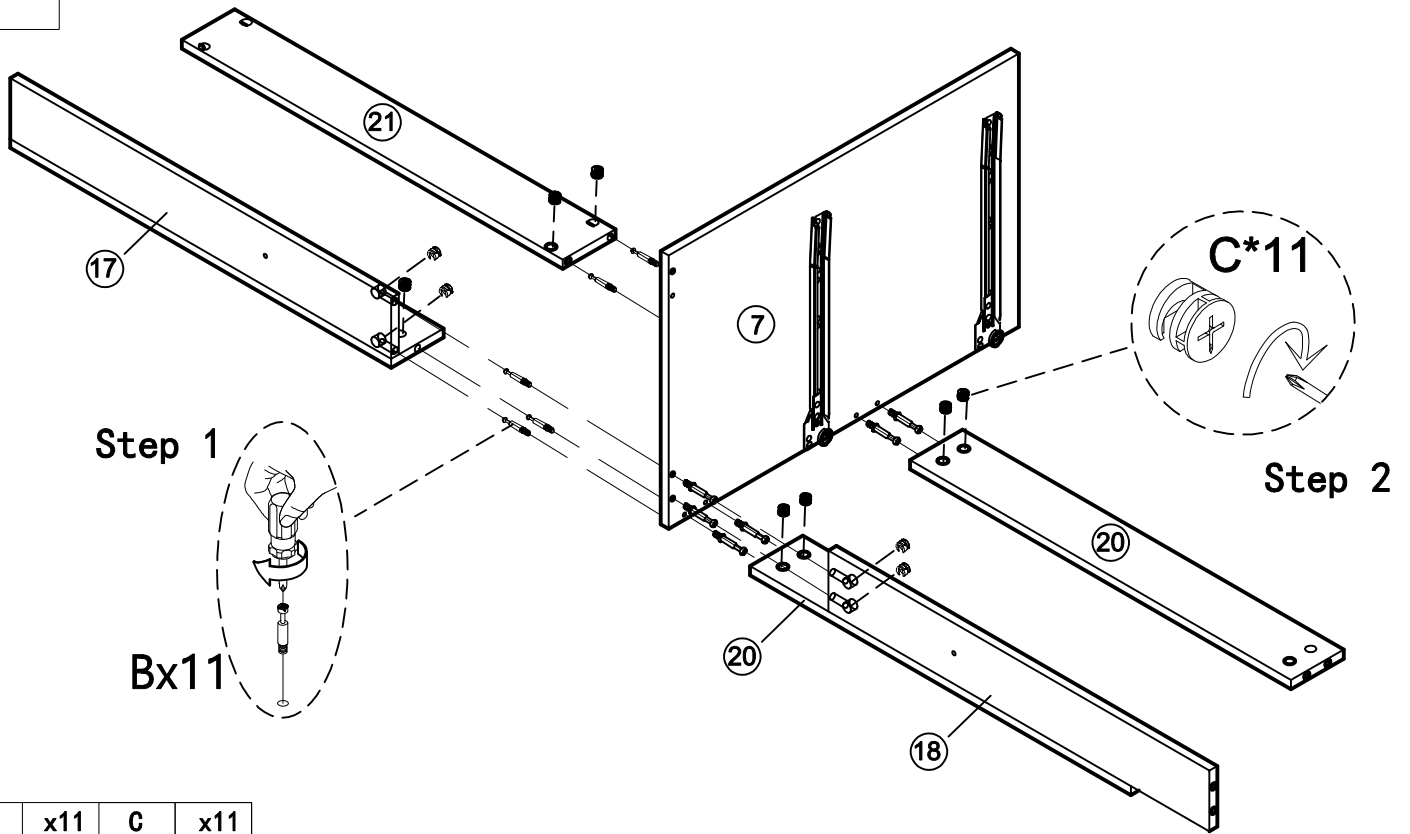

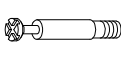
3

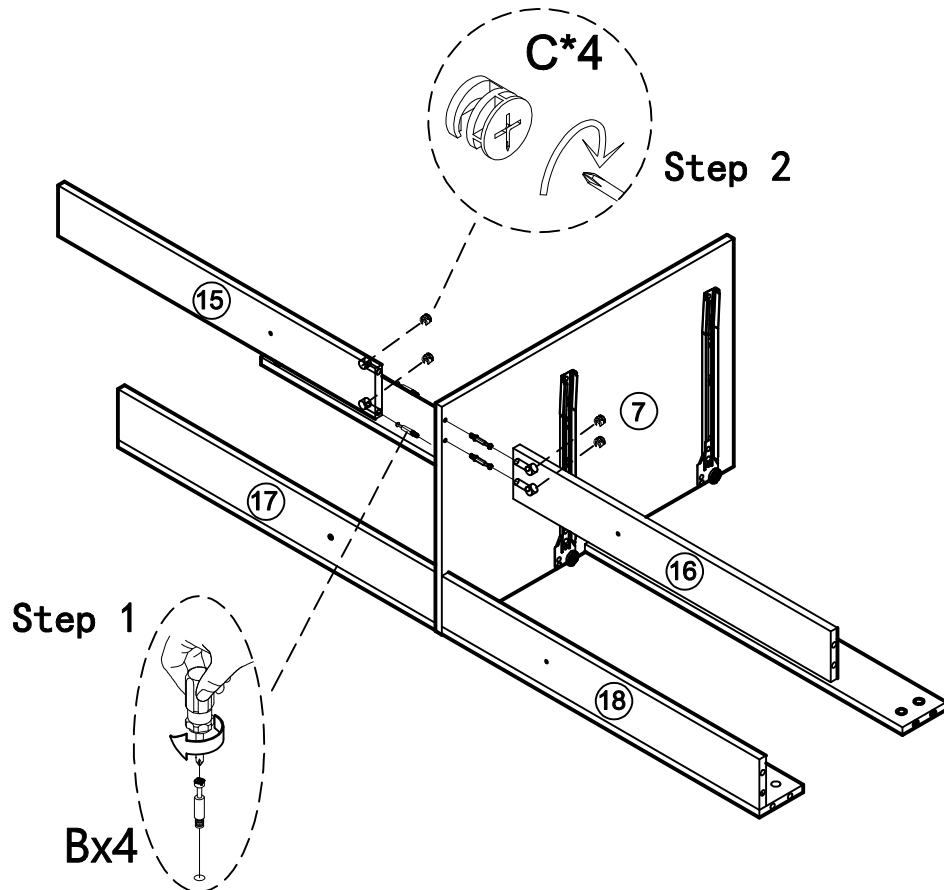

B	x11	C	x11
			
M6*25mm		Ø12mm	

4

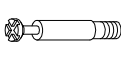

B	x4	C	x4
			
M6*25mm		Ø12mm	

5



Step 1

Bx4

C\*4

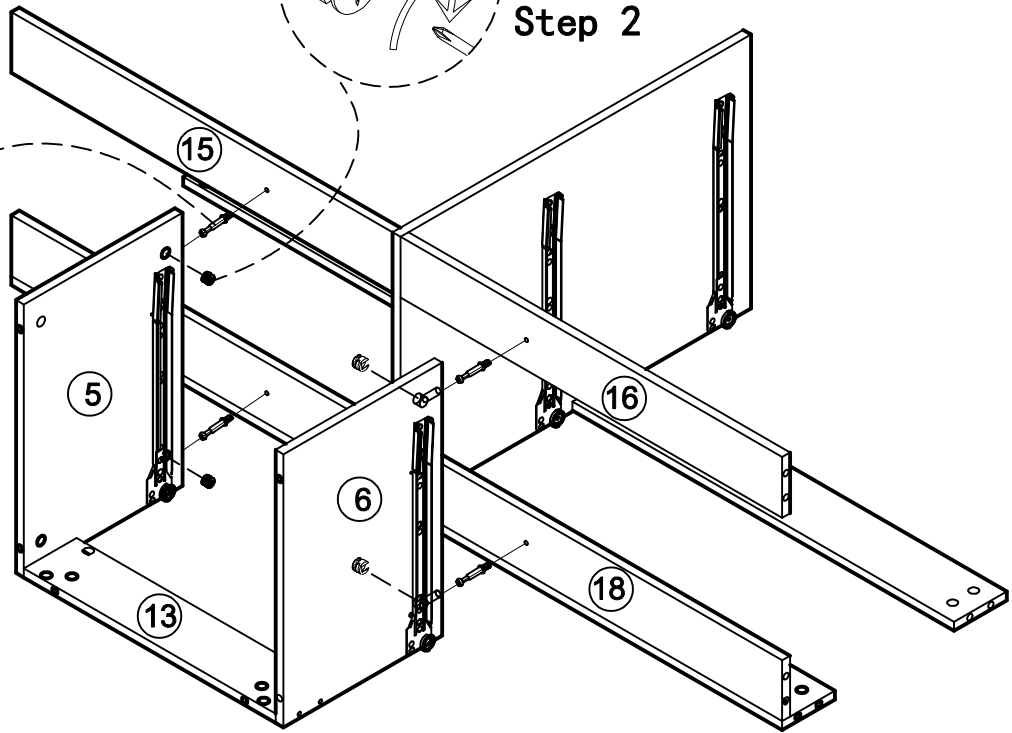
Step 2



B	x4	C	x4
			
M6*25mm		Ø12mm	

6



Step 1

Bx4

C\*4

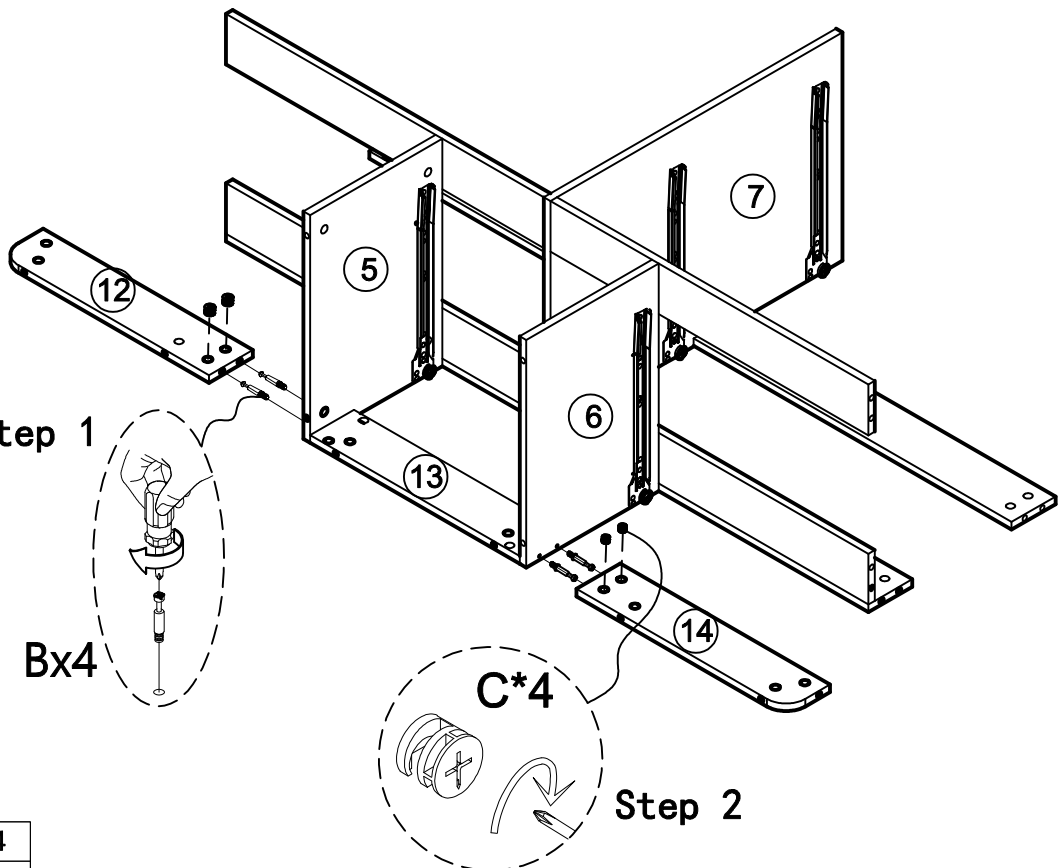
Step 2

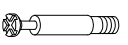

B	x4	C	x4
			
M6*25mm		Ø12mm	

7

Step 3

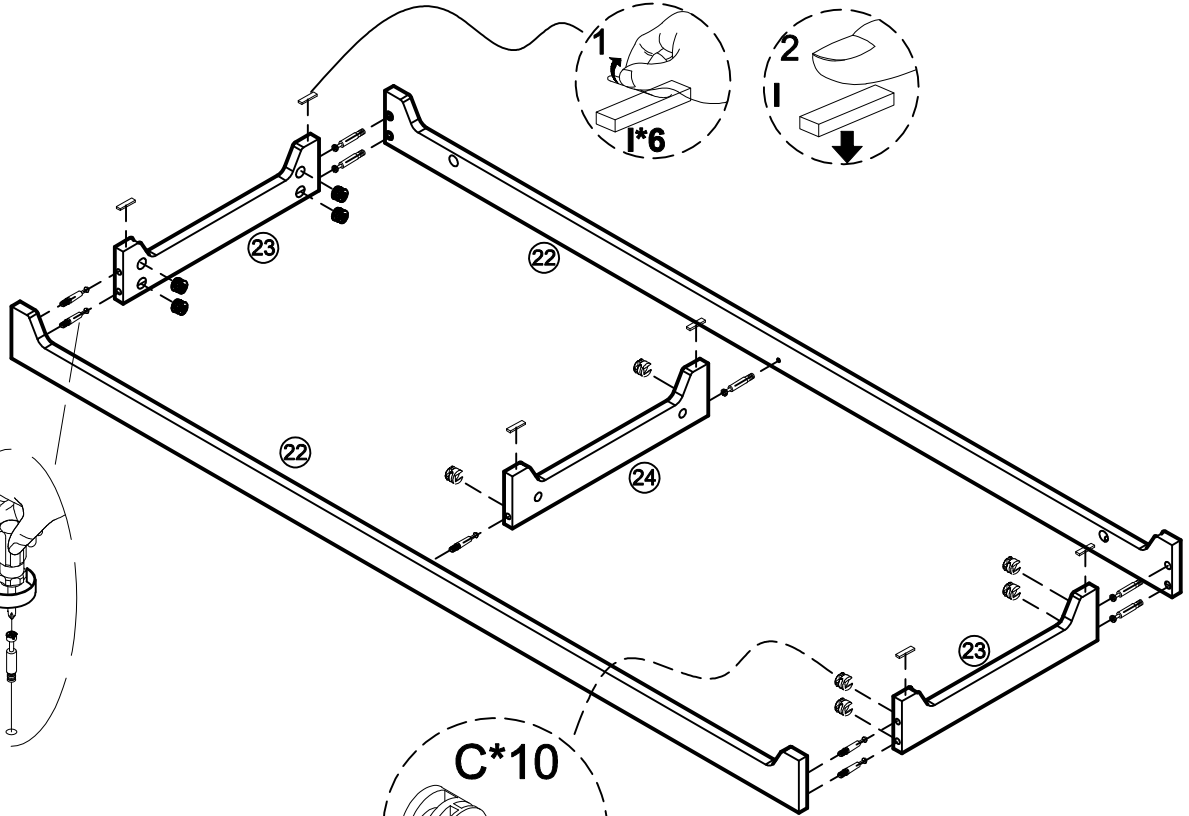

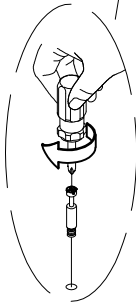

Step 1

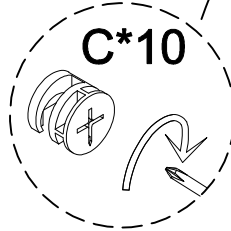

Bx10

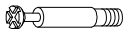

Step 2

B	x10	C	x10	I	x6
					
M6*25mm		Ø12mm		25*10*5mm	

8

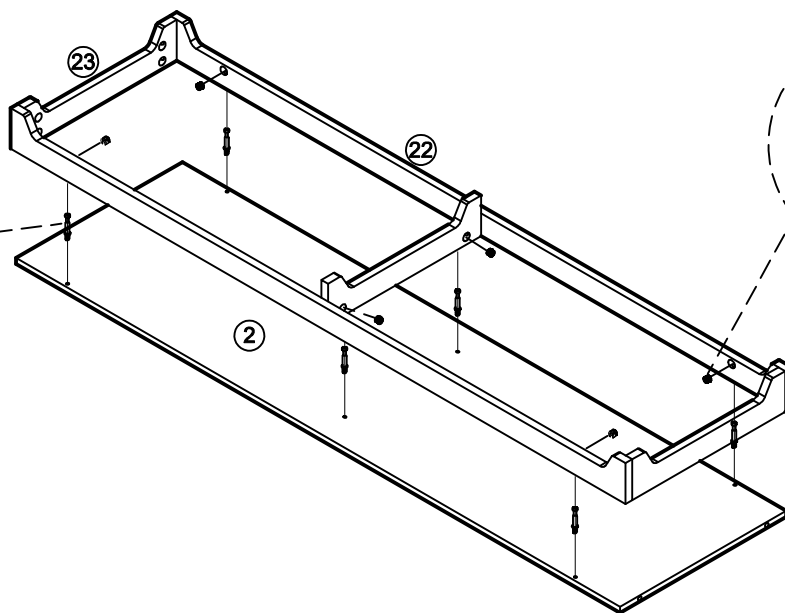

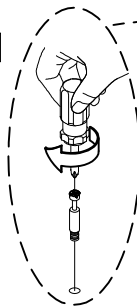

Step 1

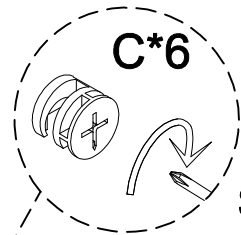

Bx6



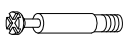

Step 2

B	x6	C	x6
			
M6*25mm		Ø12mm	

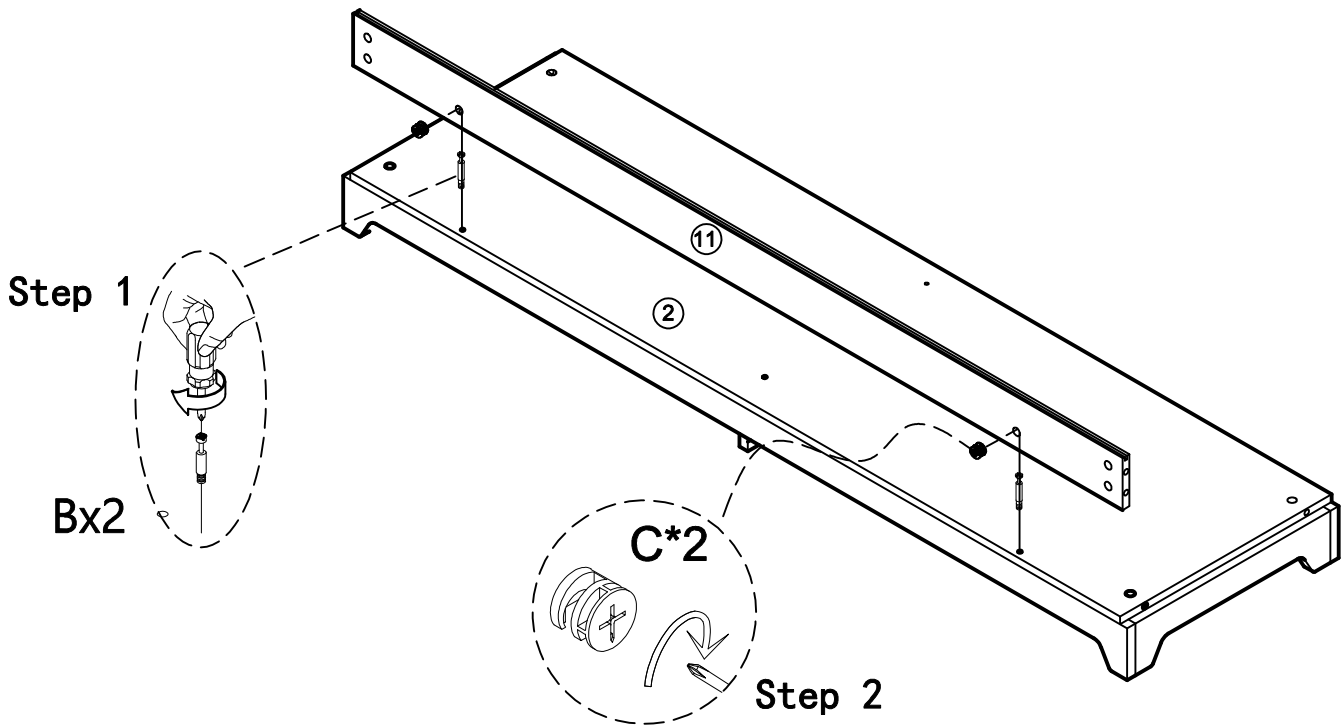

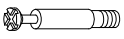
9

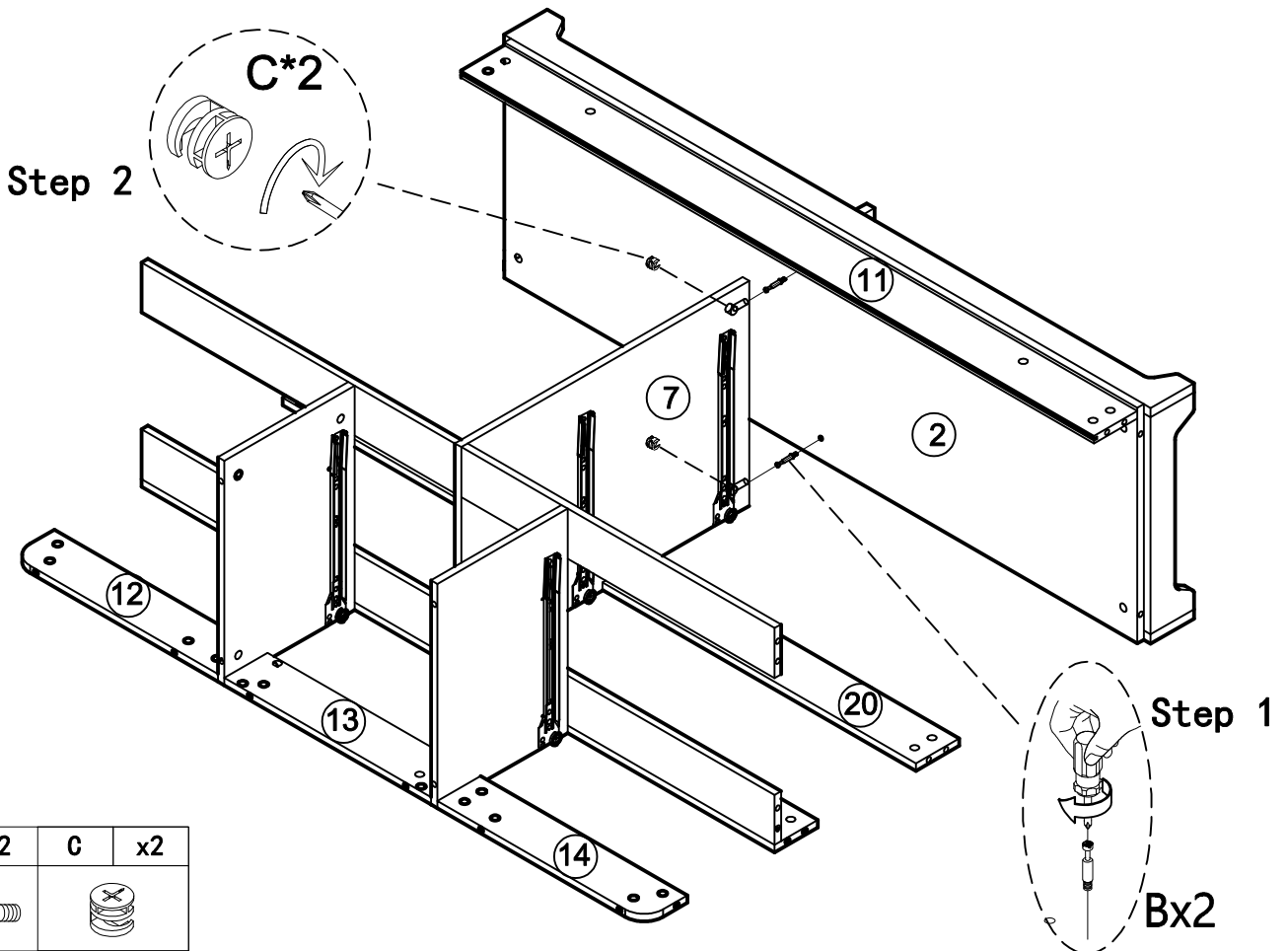

B	x2	C	x2
			
M6*25mm		Ø12mm	

10

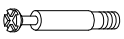

B	x2	C	x2
			
M6*25mm		Ø12mm	

11

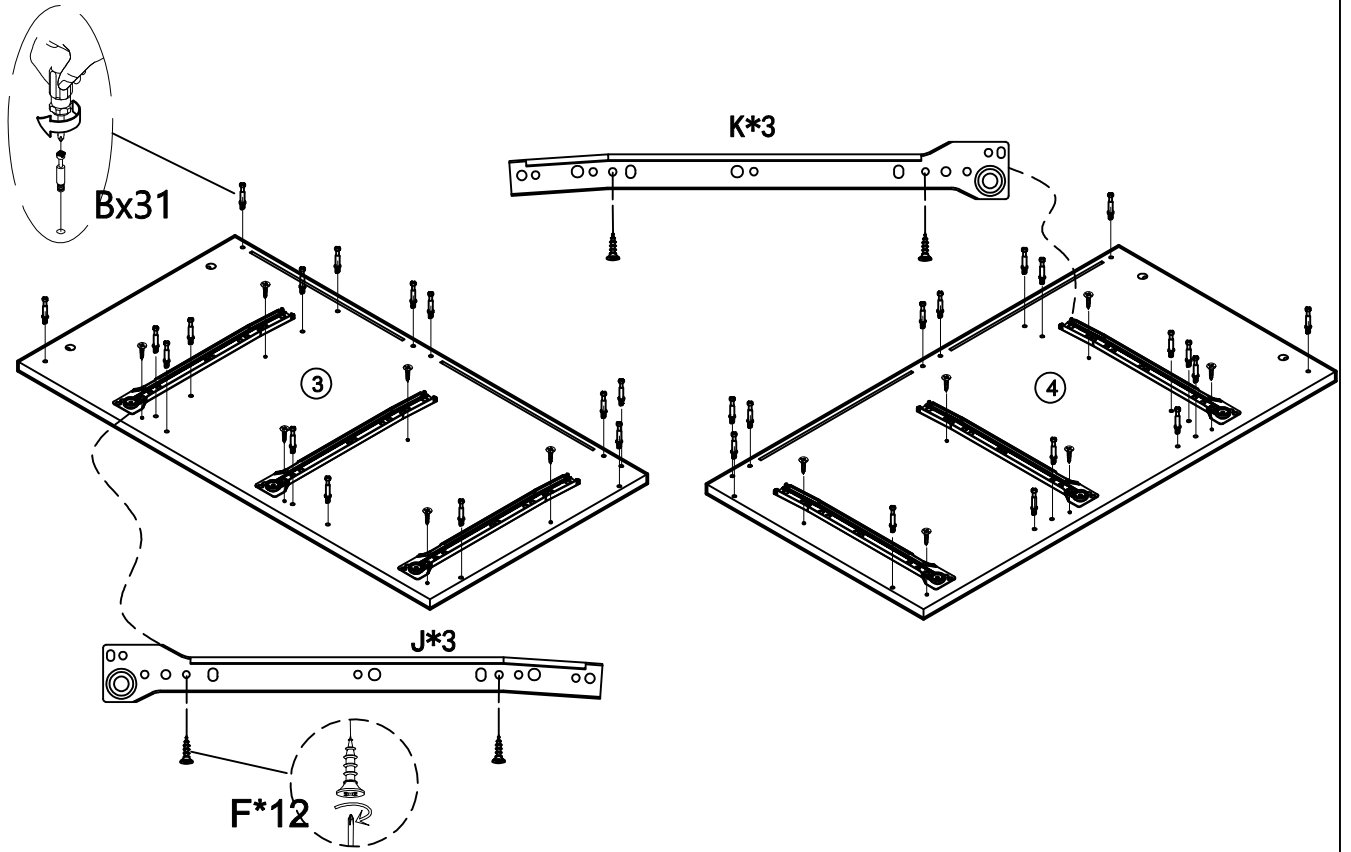

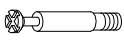
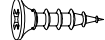
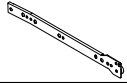
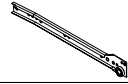
B	x31	F	x12	J	x3	K	x3
							
M6*25mm		M3*12mm		300MM		300MM	

Please ensure the screws on the drawer slides are tightened properly. Loose screws may cause the drawer to stick or jam

12

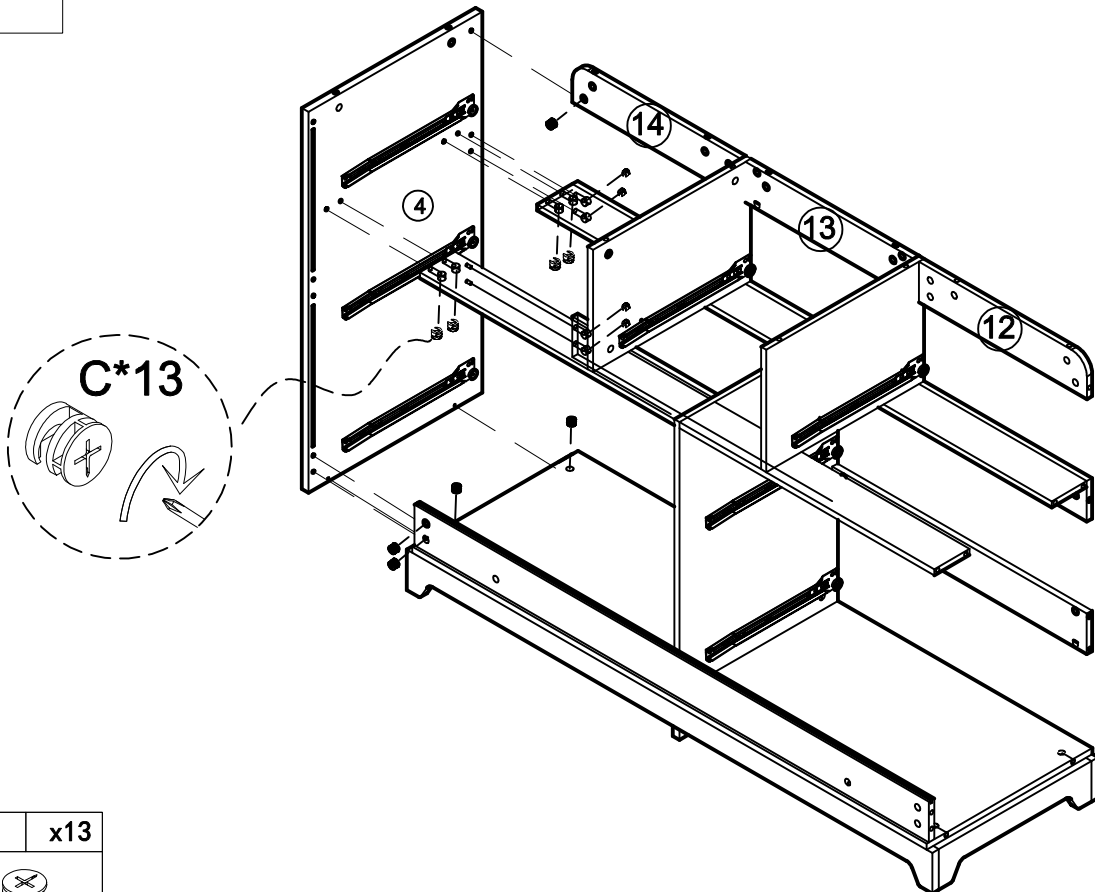

C	x13
	
Ø12mm	

13

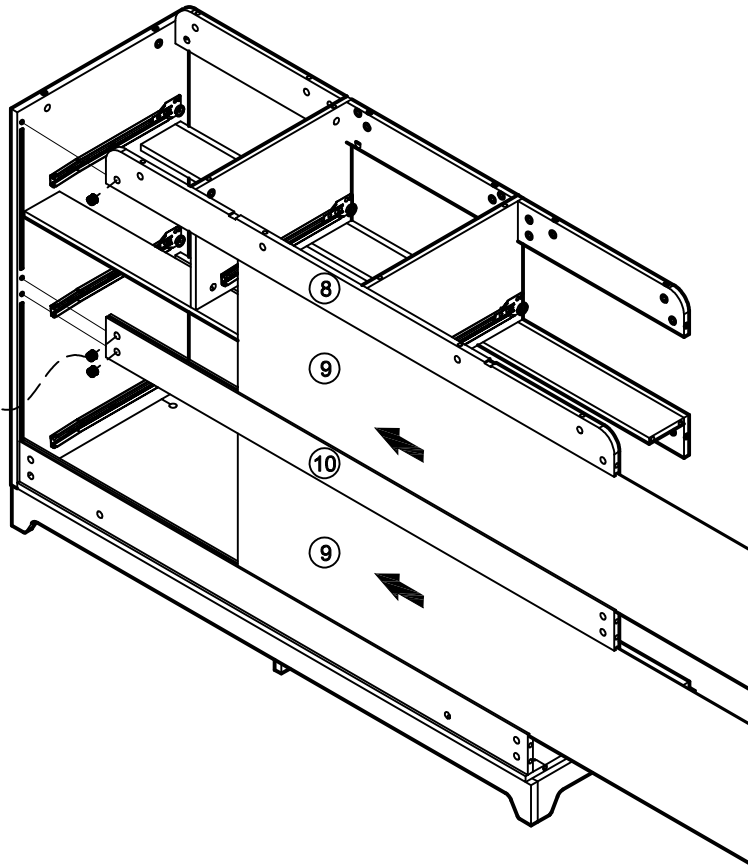
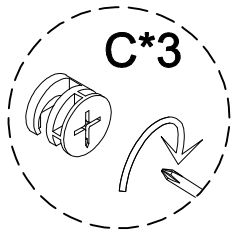

C	x3
---	----



Ø12mm

14

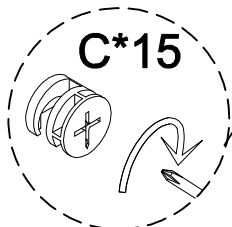
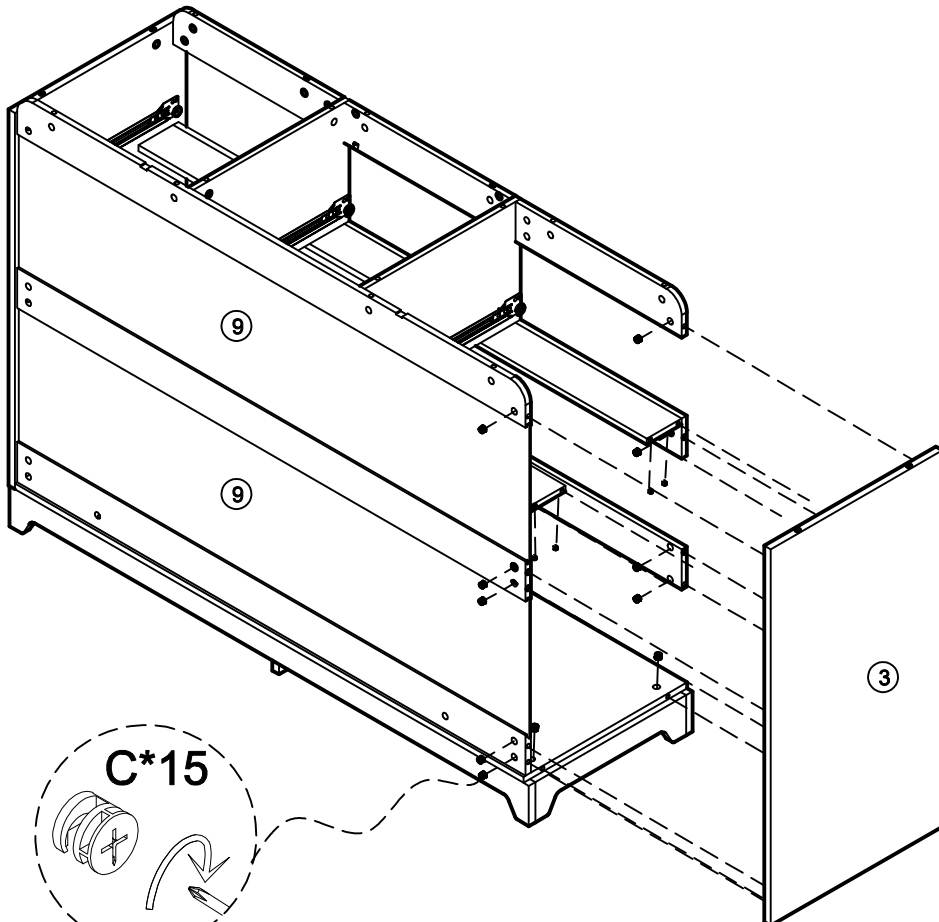



C	x15
---	-----

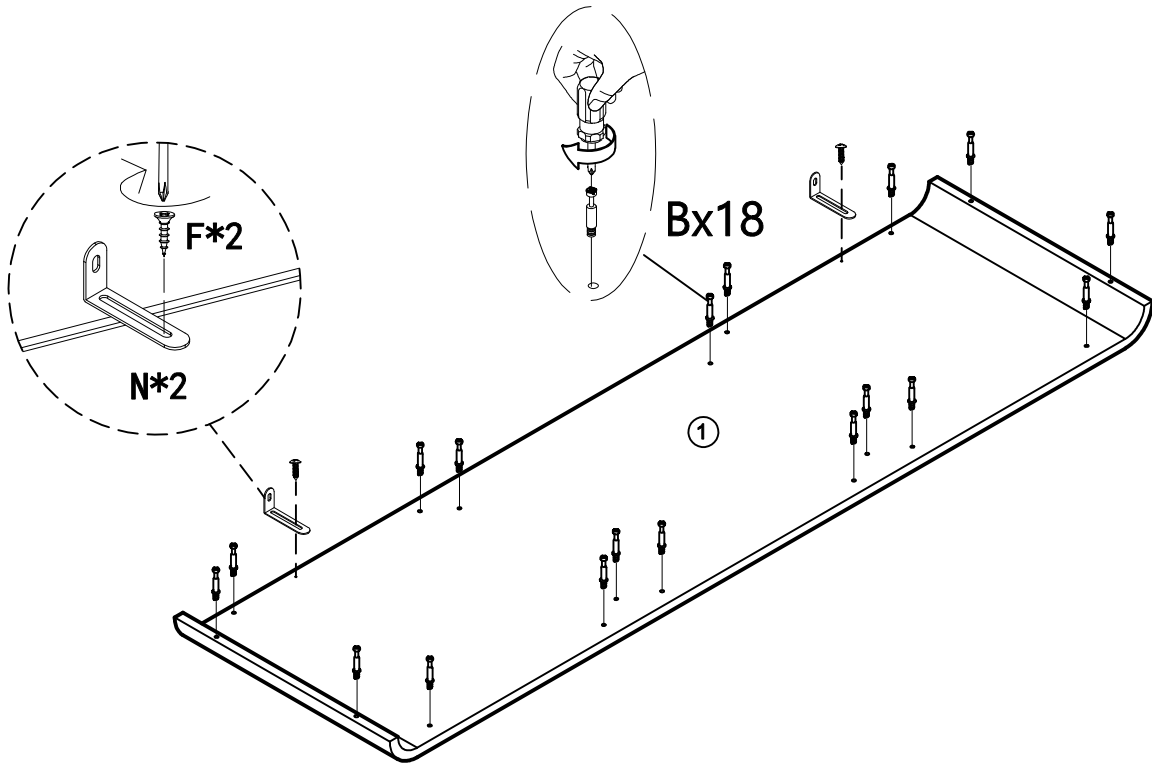

Ø12mm

15

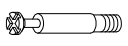

B	x18	N	x2	F	x2
					
M6*25mm		65*32*15MM		M3*12mm	

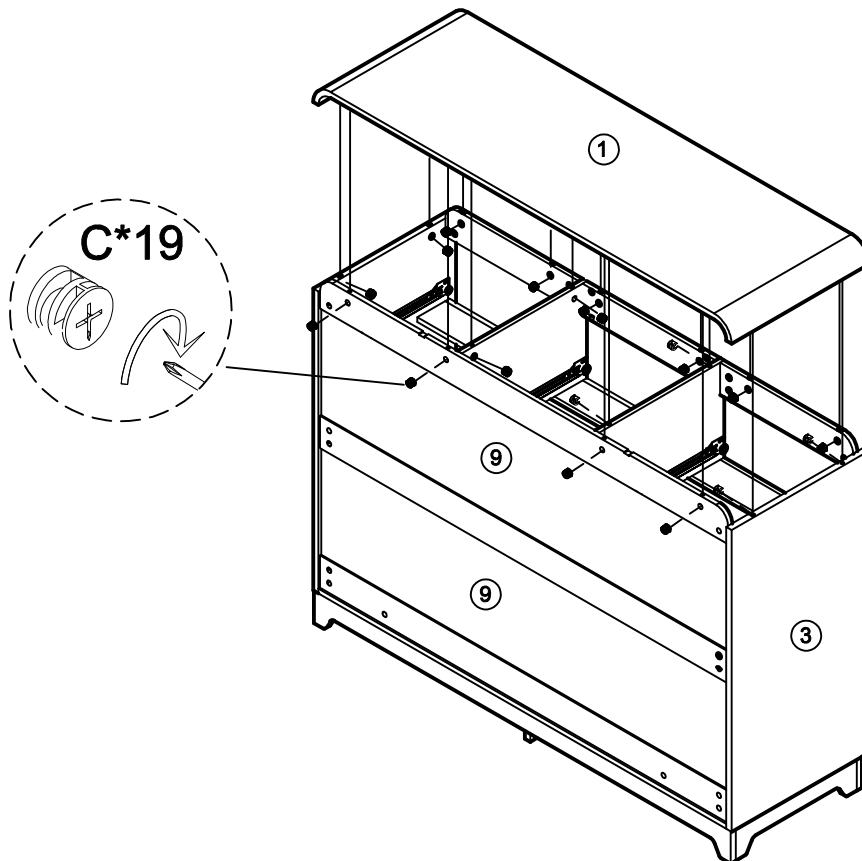

16

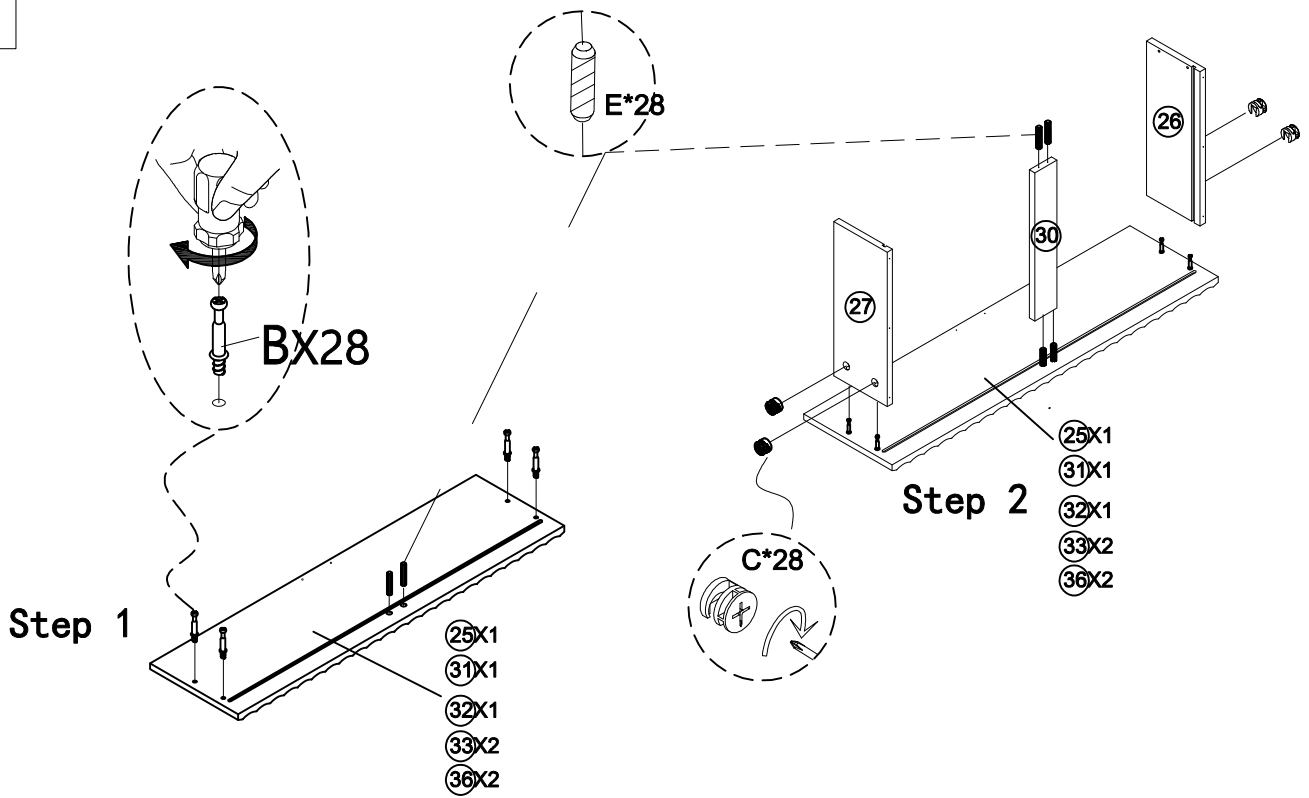

C	x18
	
Ø12mm	

17



B	x28	C	x28	E	x28
					
M6*25mm		Ø12mm		Ø8*25mm	

18

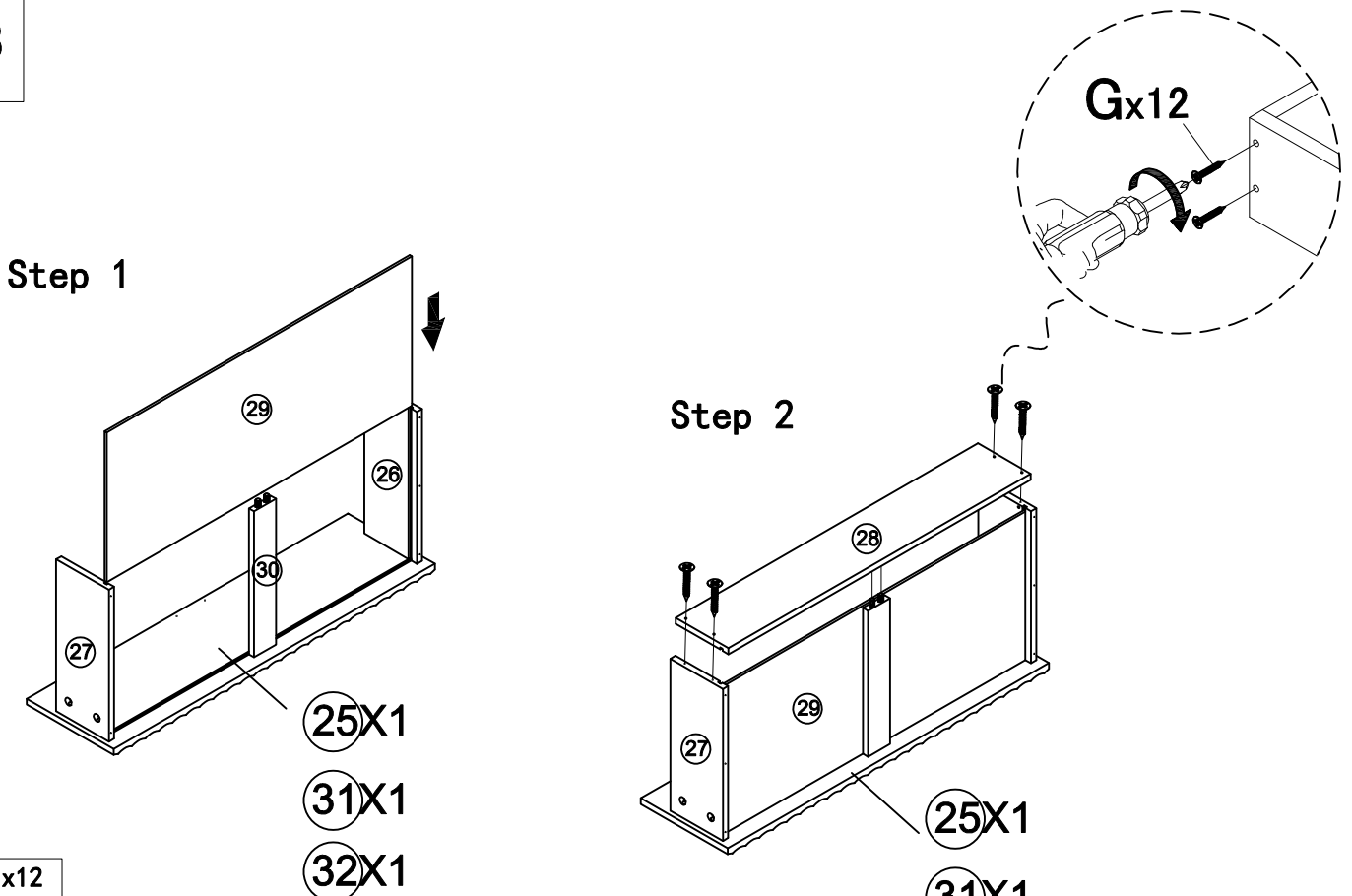

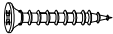
G	x12
	
M4*25mm	

19

Step 1

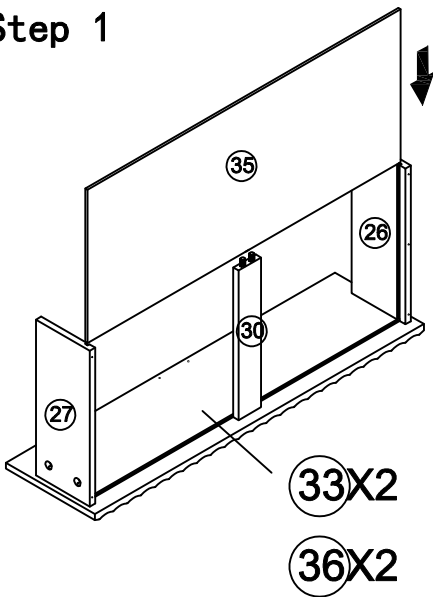

Gx16

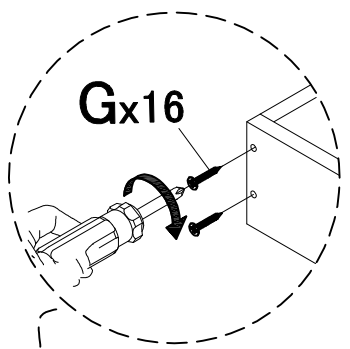

Step 2

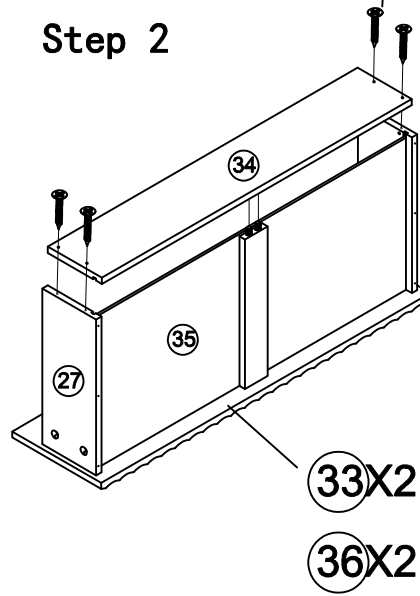

G x16

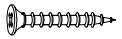

M4\*25mm

20

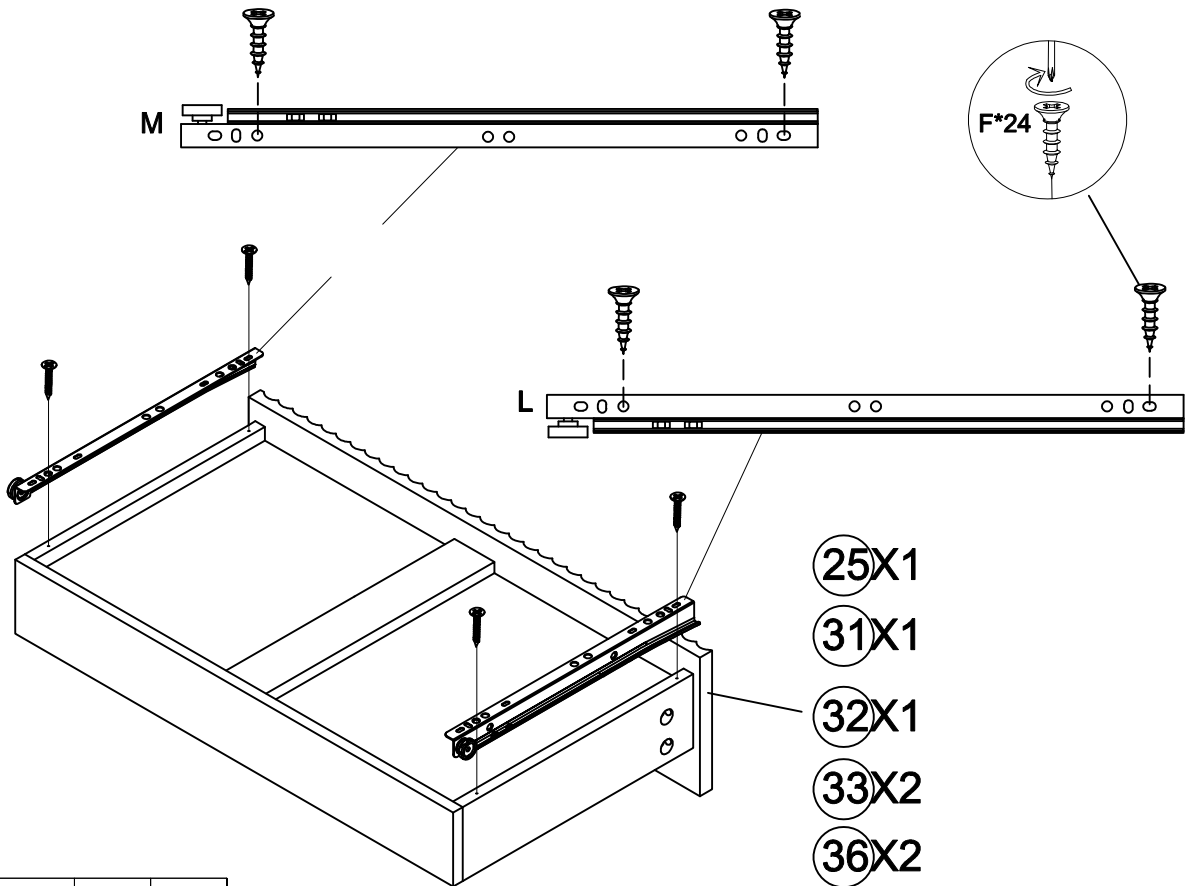

F\*24

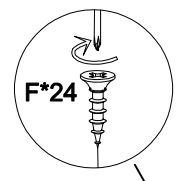

F	x42	L	x7	M	x7
M3*12mm		300MM		300MM	

Please ensure the screws on the drawer slides are tightened properly. Loose screws may cause the drawer to stick or jam

23

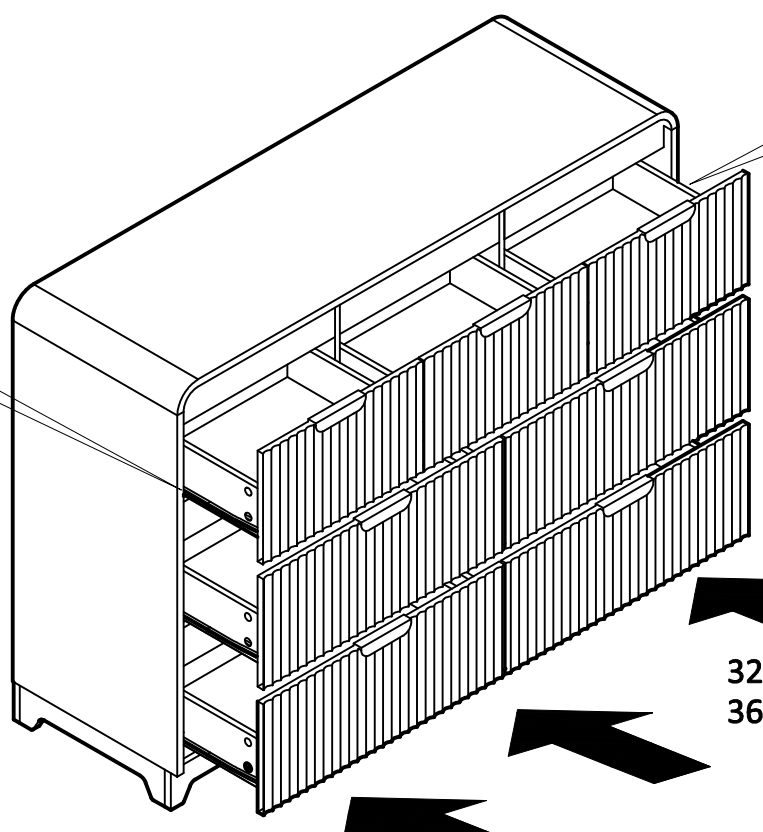
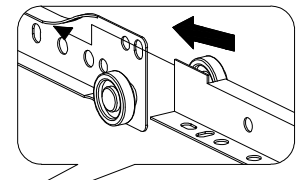
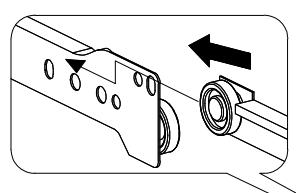
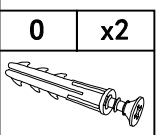
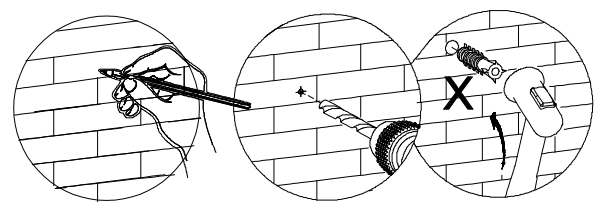
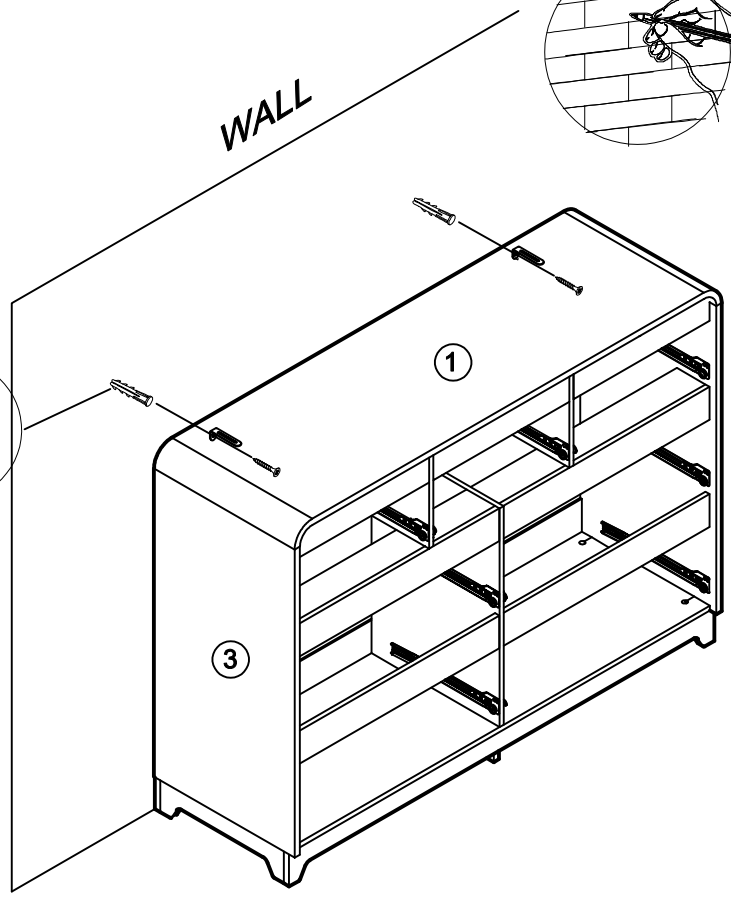
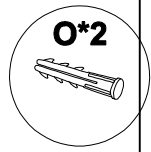



25 is left drawer  
33 is left drawer

32 is right drawer  
36 is right drawer

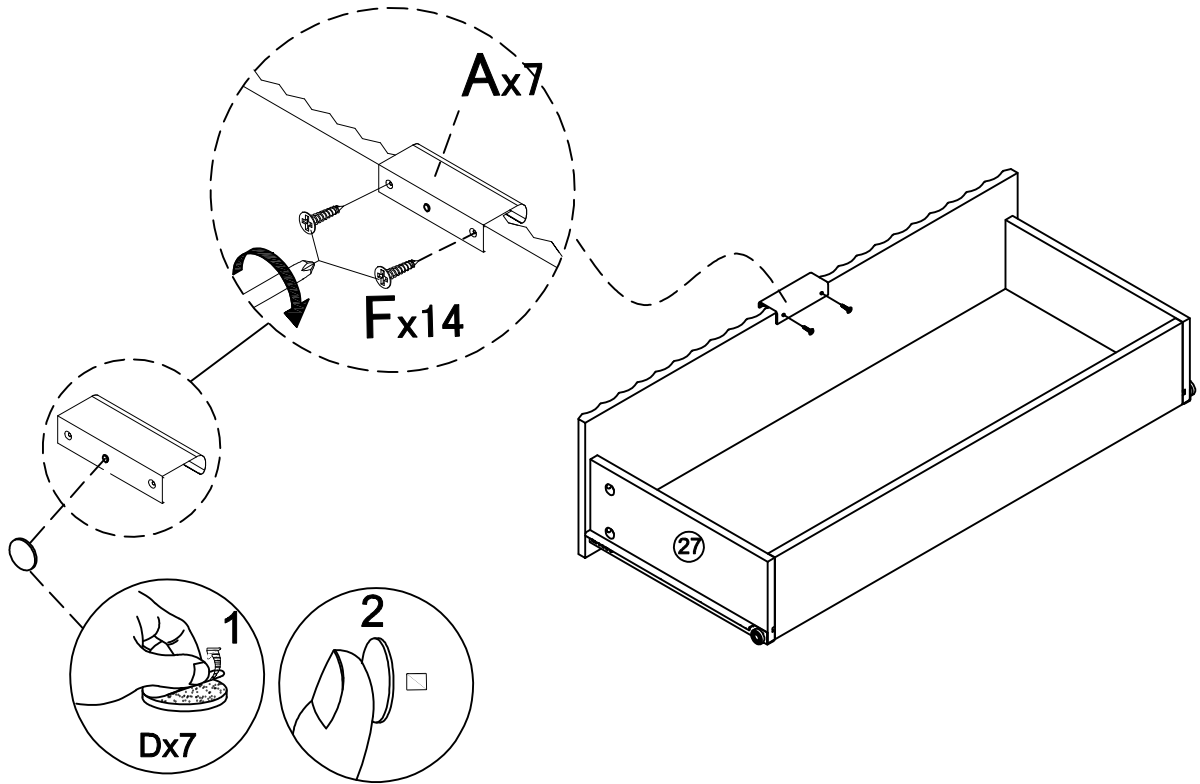
21

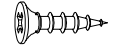

A	x7	F	x14	D	x7
					
		M3*12mm			

22

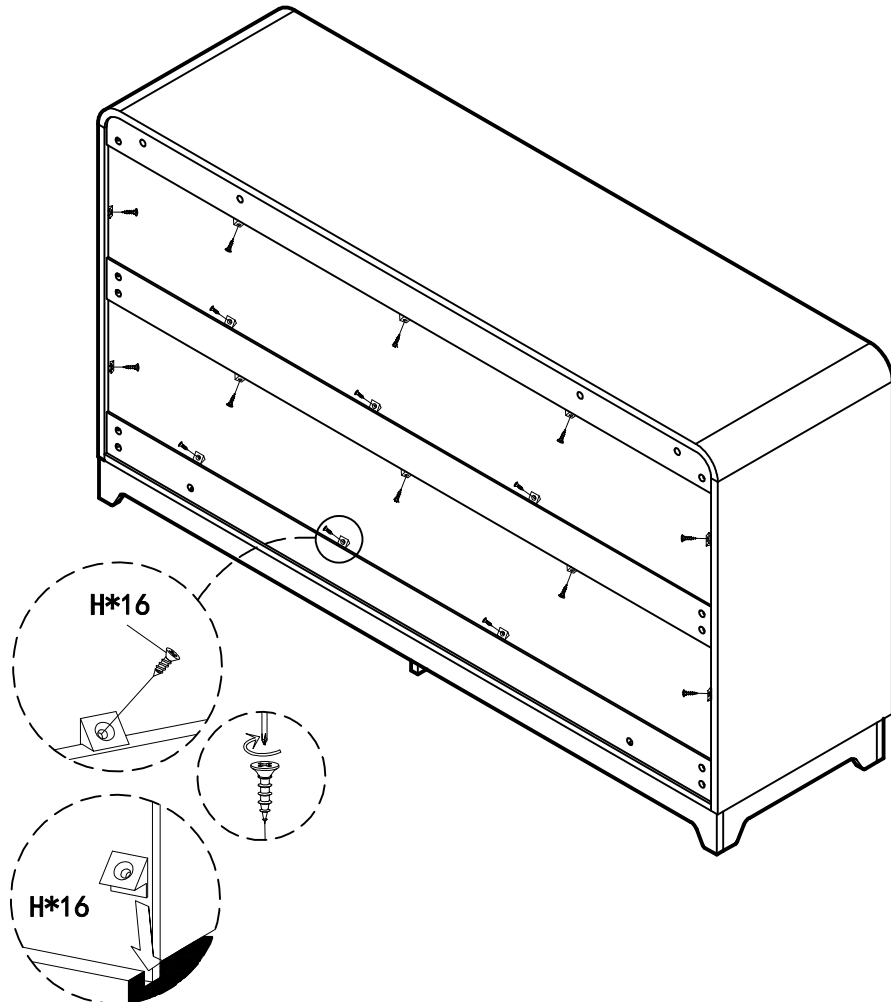

H	x16
